

Designing a first PCB

Doing it right!

Morgan Diepart ON4MOD

HamConBe, April 25, 2026

Table of contents

Introduction

Before the design

The design phase

Schematic

Layout

Manufacturing and assembly

Rounding-up

Introduction

Introduction

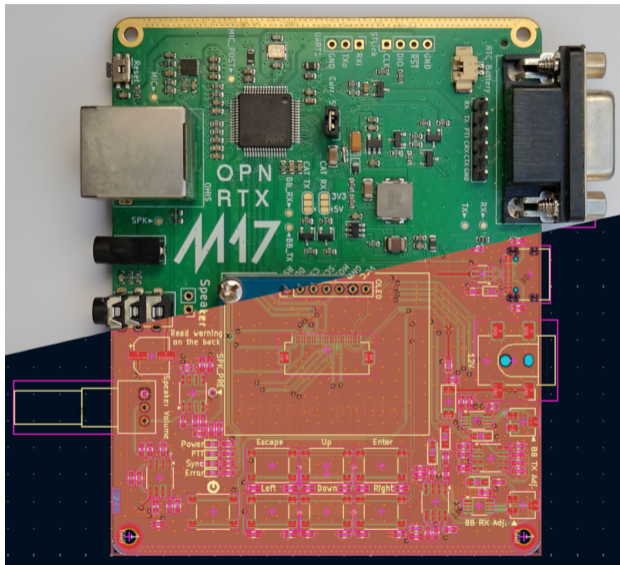

What will we talk about

And what we won't talk about

This talk is:

- ▶ a series of steps you *can* follow
- ▶ some tips to make your life easier
- ▶ designed to help you build a good (first) PCB

This talk is not:

- ▶ an electrical engineering course,
→ We have 40 minutes
- ▶ a KiCad tutorial.
→ There are numerous resources online

Asking questions - even during the presentation - is encouraged!

Before the design

Choosing your components

You have a very nice idea, and want to build it! Where to start?
→ Look for the Lego components that suits your needs

My search engines (no endorsement):



Farnell
AN AVNET COMPANY



MOUSER
ELECTRONICS.

DigiKey

Choosing your components

Not as easy to get components from:



Developing the idea



Manufacturers website contains:

- ▶ Datasheets
- ▶ White papers
- ▶ Application notes

The design phase

CAD?

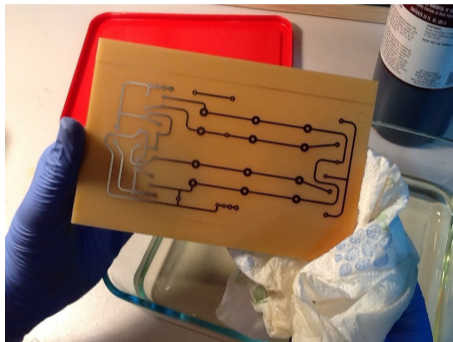

Picture by kjackman - www.flickr.com/photos/53764878@N08/

7059452663 - CC BY-SA 2.0

CAD offers:

- ▶ Much smaller features, higher density
 - ▶ Easier use of vias
 - ▶ Soldermask
 - ▶ More than two layers
- Enables high speed designs

Choose your weapon

The main ones:

Altium

- ▶ Commercial
- ▶ Supply chain-oriented
- ▶ Free version available

KiCad

- ▶ Open-source
- ▶ Feature-complete
- ▶ Easy to learn

EAGLE

- ▶ Commercial
- ▶ Integrated in Fusion
- ▶ Autodesk

EasyEDA

- ▶ Commercial
- ▶ Free version available
- ▶ Made by JLCPCB



- ▶ Open source
- ▶ Cross-platform
- ▶ Compatible with git
- ▶ Wide support from manufacturers, suppliers, community (forums), ...
- ▶ Numerous plug-ins (more on that later)

Main window

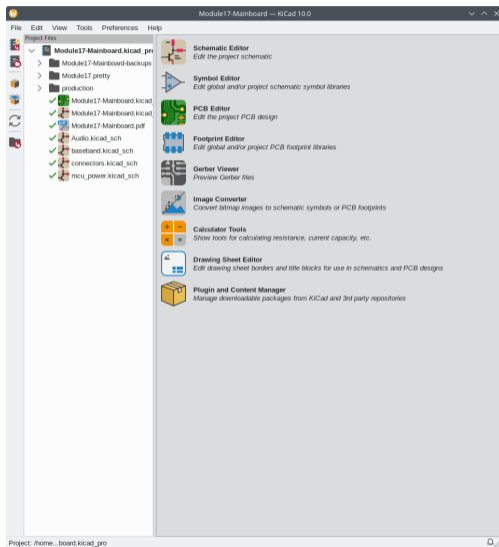

The design phase:

Schematic

Schematic editor

The screenshot displays a schematic editor window titled "mcu_power [Module17-Mainboard/MCU & Power] - Schematic Editor". The main workspace shows a complex circuit diagram for the MCU power system. Key components include:

- MCU Power Management ICs:** A central MCU block with pins labeled PA0 through PA15 and PB0 through PB15. It is connected to various power and ground pins.
- Power Regulation:** A +5V regulator section featuring a 7805 voltage regulator (U203), a 100µF electrolytic capacitor (C201), and a 0.1µF ceramic capacitor (C202).
- Switches:** Multiple tactile switches (SW201-SW208) for button power, left, right, and stop functions, each with associated pull-up resistors (R201-R208).
- Resistors and Capacitors:** Numerous resistors (R201-R208) and capacitors (C201-C207) are distributed throughout the circuit for timing and signal conditioning.
- Connectors:** Headers for "YEL_MCU" and "GND" are shown at the top of the board.

The left sidebar contains a "Schematic Hierarchy" tree with the following items:

- Module17-Mainboard (page 1)
- MCU & Power (page 2)** (selected)
- Audio & Filter (page 3)
- Connectors (page 4)
- Baseband (page 5)

At the bottom right, a metadata box provides the following information:

- Author: wjg@sch - SPPOWER
- Model: - GEMMANT
- Package: - DWHMCO
- Model: M07 Project
- Sheet: MCU & Power/
- File: mcu_power.kicad_sch
- Title: Modules7**
- Date: 2020-09-19
- Rev: Rev. 1.0
- Rev 2/8

The status bar at the bottom indicates the file path "File /home/mdepart/gb/Mo...", coordinates "X 800 Y 2650", dimensions "dx 800 dy 2650 dst 2768", grid "grid 50", and units "mts".

What you need to use

Labels. Labels everywhere.

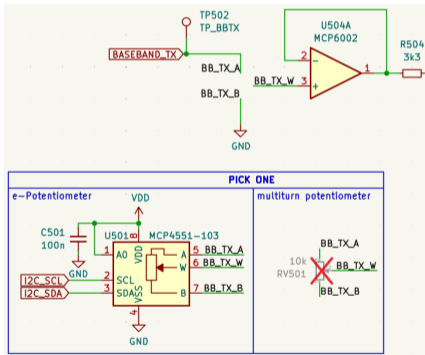

- ▶ Use labels as much as possible, it de-clutters the sheets.
- ▶ Use the proper labels adequately (global, local, hierarchical)
- ▶ Power symbols are special labels

What you need to use

Net classes

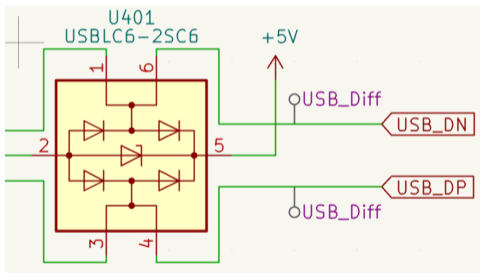

Net classes gives some parameters to the net it is connected to.

Using net class labels make it clear and apparent.

What you need to use

Components fields

Name	Value	Show	Show Name	H/Align	V/Align	Italic	Bold
Reference	C211	<input checked="" type="checkbox"/>	<input type="checkbox"/>	Left	Center	<input type="checkbox"/>	<input type="checkbox"/>
Value	4.7uF	<input checked="" type="checkbox"/>	<input type="checkbox"/>	Left	Center	<input type="checkbox"/>	<input type="checkbox"/>
Footprint	Capacitor_SMD-C_0805_2012Metric	<input type="checkbox"/>	<input type="checkbox"/>	Center	Center	<input type="checkbox"/>	<input type="checkbox"/>
Datasheet		<input type="checkbox"/>	<input type="checkbox"/>	Center	Center	<input type="checkbox"/>	<input type="checkbox"/>
Description		<input checked="" type="checkbox"/>	<input type="checkbox"/>	Center	Center	<input type="checkbox"/>	<input type="checkbox"/>
Dielectric	X5R or better	<input checked="" type="checkbox"/>	<input type="checkbox"/>	Center	Center	<input type="checkbox"/>	<input type="checkbox"/>
Rated voltage	50V or higher	<input checked="" type="checkbox"/>	<input type="checkbox"/>	Center	Center	<input type="checkbox"/>	<input type="checkbox"/>
ESR	less than 1 Ohm	<input checked="" type="checkbox"/>	<input checked="" type="checkbox"/>	Center	Center	<input type="checkbox"/>	<input type="checkbox"/>
MPN	Generic C/4.7uF/0805/X5R/25V	<input type="checkbox"/>	<input type="checkbox"/>	Center	Center	<input type="checkbox"/>	<input type="checkbox"/>

General

Unit:

Body style:

Angle: 0

Mirror: Not mirrored

Show pin numbers Show pin names

Attributes

Exclude from simulation

Exclude from bill of materials

Exclude from board

Exclude from position files

Do not populate

Update Symbol from Library...

Change Symbol...

Edit Symbol...

Edit Library Symbol...

Library link: Devic:C

Simulation Model... Annotate Validate

You can add fields
(parameters) to your
components:

- ▶ MPN for specific components
- ▶ Precision
- ▶ Dielectric for capacitors
- ▶ Supplier order code

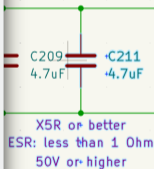

Schematic tips

Understand your components



Know the component you will place,
sometimes down to the exact reference.

Light Bulb or Idea Flat Icon Vector.svg from Wiki-
media Commons by Videoplasty.com, CC-BY-SA 4.0

Schematic tips

Text and drawing



Do not be shy with text, comments and drawings to make your intentions more explicit.

Light Bulb or Idea Flat Icon Vector.svg from Wikimedia Commons by Videoplasty.com, CC-BY-SA 4.0

To sum up

It looks like we simply:

- ▶ Place components
- ▶ Draw wires

To sum up

But it is actually more than that...

- ▶ Place components **with values, footprint, comments, fields**
- ▶ ~~Draw wires~~ Create nets, with net classes
- ▶ We are telling the next guy what we mean That guy is often you...

The design phase:

Layout

Layout editor

The screenshot displays the PCB Editor interface for a project named "Module17-Mainboard". The main workspace shows a detailed PCB layout with various components, traces, and pads. The layout is primarily orange, representing the copper layer, with various colored elements for other layers and components.

BOARD CHARACTERISTICS

Copper Layer Count:	4	Board Thickness:	1.6062 mm
Board overall dimensions:	100.0000 mm x 83.0000 mm	Min hole diameter:	0.3000 mm
Min track/spacing:	0.1500 mm / 0.1000 mm	Impedance Control:	No
Copper Finish:	None	Plated Board Edge:	No
Castellated pads:	No		
Edge card connectors:	No		

Layers Panel:

- F.Cu
- In1.Cu
- In2.Cu
- B.Cu
- F.Adhesive
- B.Adhesive
- F.Paste
- B.Paste
- F.Silkscreen
- B.Silkscreen
- F.Mask
- B.Mask
- User Drawings
- User Comments
- User Eco1
- User Eco2
- Edge Cuts
- Margin
- F.Courtyard
- B.Courtyard
- F.Fab
- B.Fab
- User1
- User2
- User3
- User4
- User5
- User6

Selection Filter:

- All Items
- Footprints
- Tracks
- Pads
- Zones
- Dimensions
- Points
- Locked Items
- Text
- Vias
- Graphics
- Rule Areas
- Other Items

Status Bar:

Pads: 644 | Vias: 1236 | Track Segments: 1391 | Nets: 151 | Unrouted: 0
Z: 1.61 | X: 166.5000 | Y: 79.0000 | dx: 166.5000 | dy: 79.0000 | d... | grid: 0.5000 | mm

What you need to use

Stack-up

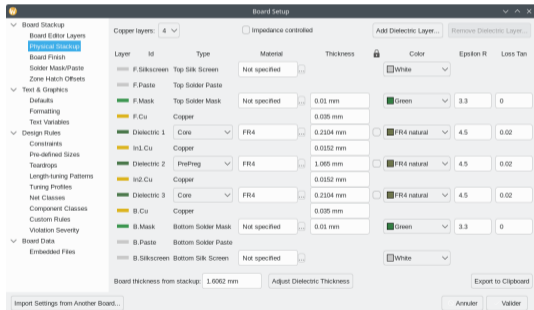

How many layers do you need?

▶ 2 layers

▶ Layer 1: GND + signals + components

▶ Layer 2: GND + signals (+ components)

▶ 4 layers

▶ Layer 1: Signals + components

▶ Layer 2: GND only

▶ Layer 3: Power

▶ Layer 4: Signals (+ components)

What you need to use

Design Rules Checker

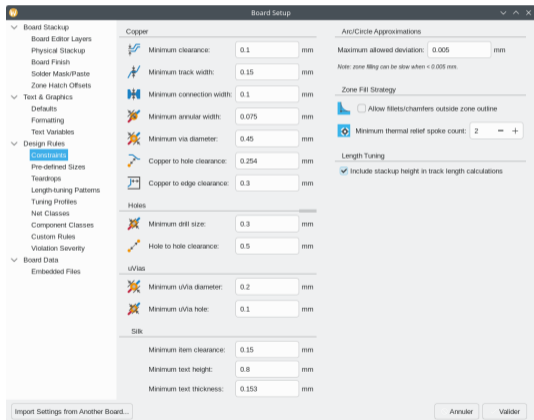

The design rules checker ensures that you avoid layout errors.

It needs to be configured beforehand.

→ Check your manufacturer requirements

Layout tips

Take your time



Light Bulb or Idea Flat Icon Vector.svg from Wikimedia Commons by Videoplasty.com, CC-BY-SA 4.0

Layout is a long process, take your time:

- ▶ avoid floating copper,
- ▶ avoid parasitic antennas,
- ▶ shorten current return paths,
- ▶ use at least two vias per decoupling capacitor,
- ▶ use silkscreen for components references and other useful labels.

Layout tips

Pay attention to footprints



Light Bulb or Idea Flat Icon Vector.svg from Wikimedia Commons by Videoplasty.com, CC-BY-SA 4.0

Some components are very (very) small.

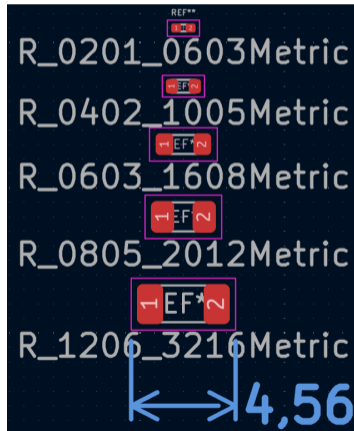

Layout tips

Pay attention to footprints



Light Bulb or Idea Flat Icon Vector.svg from Wikimedia Commons by Videoplasty.com, CC-BY-SA 4.0

Double, or triple check your footprints!!

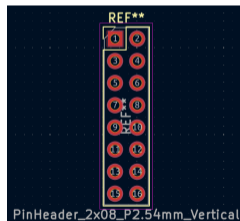
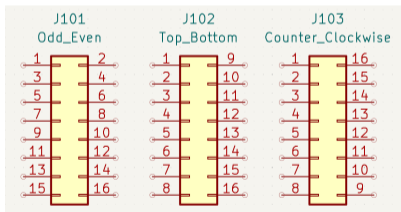

Layout tips

Think about assembly and manufacturing



Light Bulb or Idea Flat Icon Vector.svg from Wikimedia Commons by Videoplasty.com, CC-BY-SA 4.0

Already think about manufacturing and assembly.

Some design choices make the design less robust when mass-manufacturing.

- ▶ Respect minimal clearance around components
- ▶ No tracks below passive components
- ▶ The larger the board, the higher the price

Layout tips

You are a member of a community



Experts sometimes hide in plain sight!

Light Bulb or Idea Flat Icon Vector.svg from Wikimedia Commons by Videoplasty.com, CC-BY-SA 4.0

The design phase:

Manufacturing and assembly

Select a manufacturer

It can influence the design of the board (some have stricter DRC constraints).

The two main manufacturers (cheap, from china). Provide PCB fabrication and assembly.



Select a manufacturer

There are many European manufacturers, usually for high-tech PCB (flex, semi-flex, high-density, with microvias, ...)



AISLER



Provides fabrication and assembly.

Only provides fabrication.

Export the manufacturing files

The screenshot shows the 'Plugin And Content Manager' window in KiCad. The window title is 'Plugin And Content Manager'. At the top, there are tabs for 'Repository (103)', 'Installed (1)', and 'Pending (0)'. Below this, a dropdown menu shows 'KICad official repository' and a 'Manage...' button. The main area is divided into two panes. The left pane is a list of plugins, with 'AISLER Push for KiCad' selected and highlighted in blue. Other plugins listed include 'PCBWay Plug-in for KiCad', 'Sierra Quote Plugin', 'PCBWay Fabrication Toolkit', 'HQ PCB', 'NextPCB', and 'gerber2png Plug-in for KiCad'. Each plugin entry includes a small icon, a title, a brief description, and an 'Install' button. The right pane shows the details for the selected 'AISLER Push for KiCad' plugin. It includes a description: 'Want to use Powerful Prototyping or Amazing Assembly from AISLER? This plugin will provide you with a convenient one-click push to our service.' It also lists features: Gerber Files in the right format, IPC-Netlist-File to enable Smart Tests, BOM-file to import all components, and PnP-file to get your project ready for assembly. Below this is a paragraph about the upload process and a section titled 'About AISLER:' which describes the service's mission. At the bottom of the right pane is a 'Metadata' section with a list of package identifiers, license, and author information, including GitHub and Twitter links. At the very bottom of the window, there are buttons for 'Refresh', 'Install from File...', 'Open Package Directory', 'Apply Pending Changes', 'Discard Pending Changes', and 'Close'.

Each manufacturer has requirements on the exact file format to use.

Some even have plug-ins available to ensure a correct file export.

What tools do you need?

Assembly



Pinecil USB C soldering iron.jpg from Wikimedia Commons by 4300streetcar, CC-BY 4.0



Binocular Microscope at Gemini North Hilo Base Facility (6V7A0537-CC).jpg from Wikimedia Commons by International Gemini Observatory/NOIRLab/NSF/AURA/T. Slovinsky, CC-BY 4.0

What tools do you need?

Debug and bring-up



Sourcing your components

If you need to source parts:



DigiKey



Those do not have to be the same ones you used at the beginning to search for existing components ;)

Rounding-up

Rounding-up

PCB design is an iterative process!

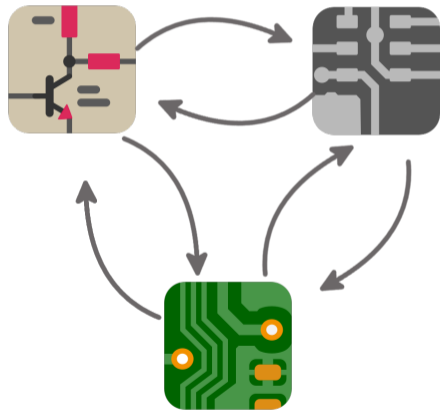

Rounding-up

Some useful resources to help you iterate:

KiCad Documentation <https://docs.kicad.org/>

KiCad Forums <https://forum.kicad.info/>

KiCad Subreddit <https://www.reddit.com/r/KiCad/>

Another good forum <https://electronics.stackexchange.com/>

Videos Large number of video tutorials are available online!

Offline Ask around you!

Thank you

Don't hesitate to ask questions about PCBs, KiCad, electronics, or whatever you feel like asking.

Contact me: morgandiepart@ikmail.com

