

Experimental Aerodynamics of a High-Speed Low-Pressure turbine

Antonino Federico Maria Torre^{1,2}, Sergio Lavagnoli¹, Samuel Gendebien¹, Koen Hillewaert²

¹Turbomachinery and Propulsion Department, von Karman Institute for Fluid Dynamics; ²Département d'aérospatiale et mécanique, University of Liège

High Speed Low-Pressure Turbine Aerodynamics

Research Aim

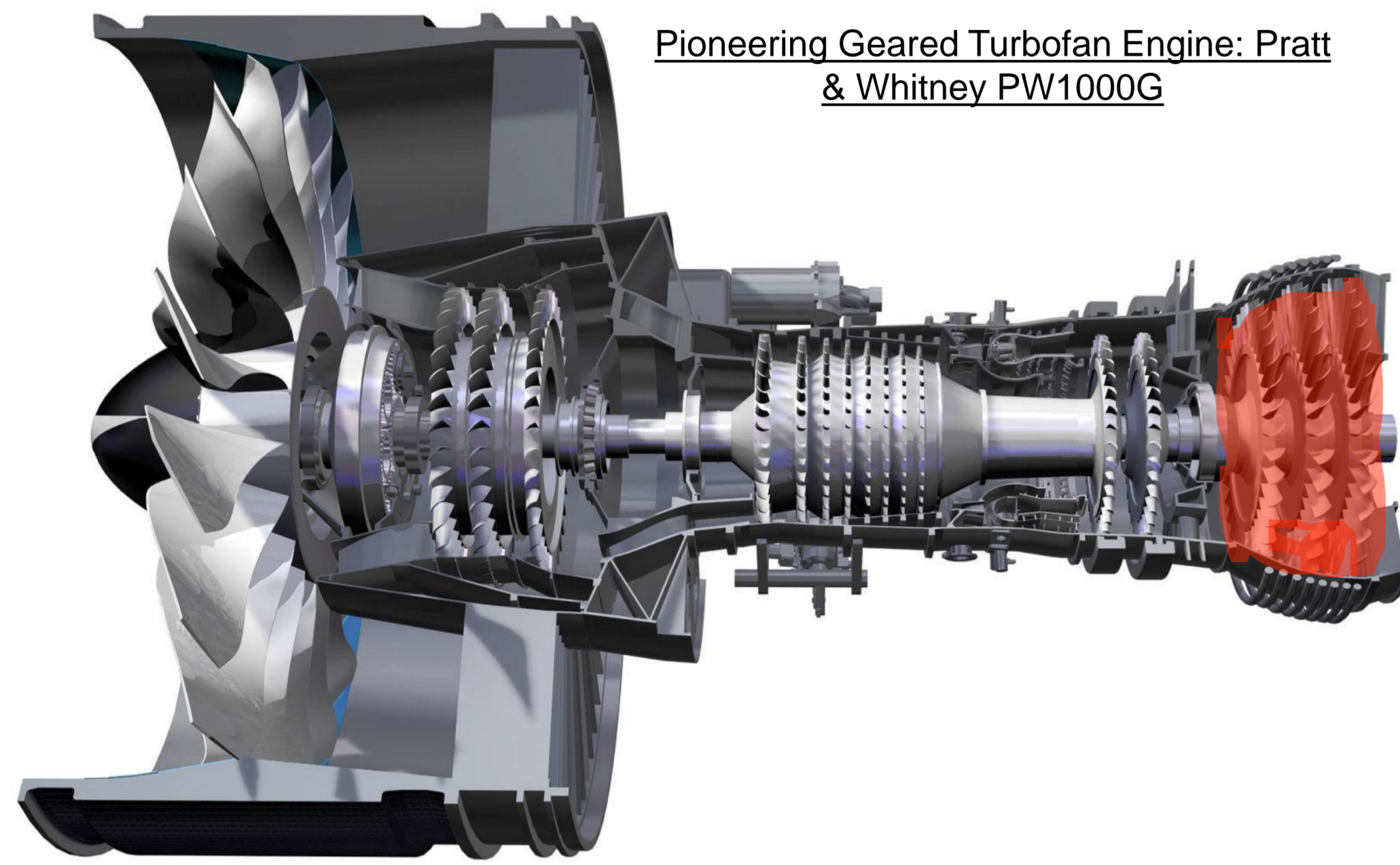

Pioneering Geared Turbofan Engine: Pratt & Whitney PW1000G

Environment

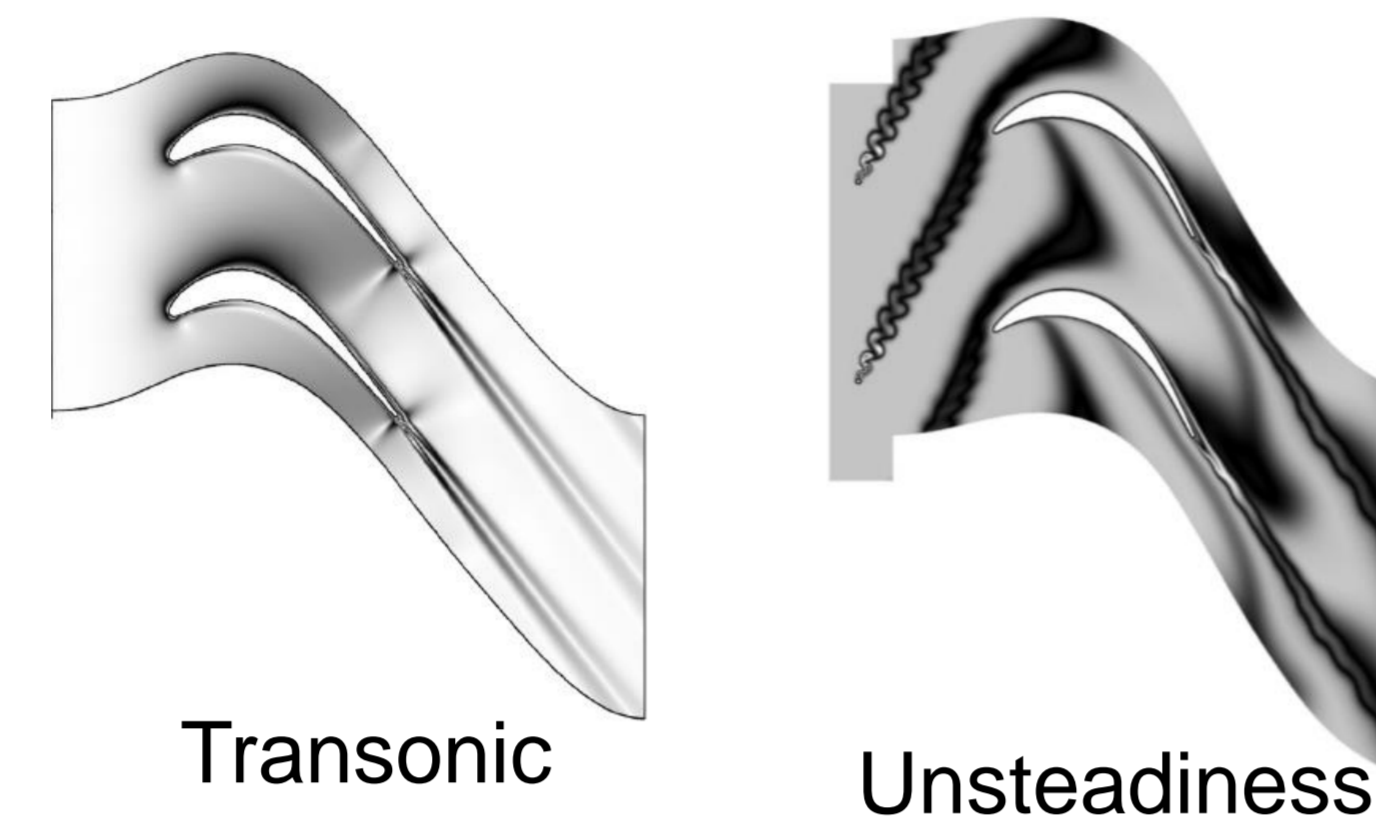

Combined sources of loss

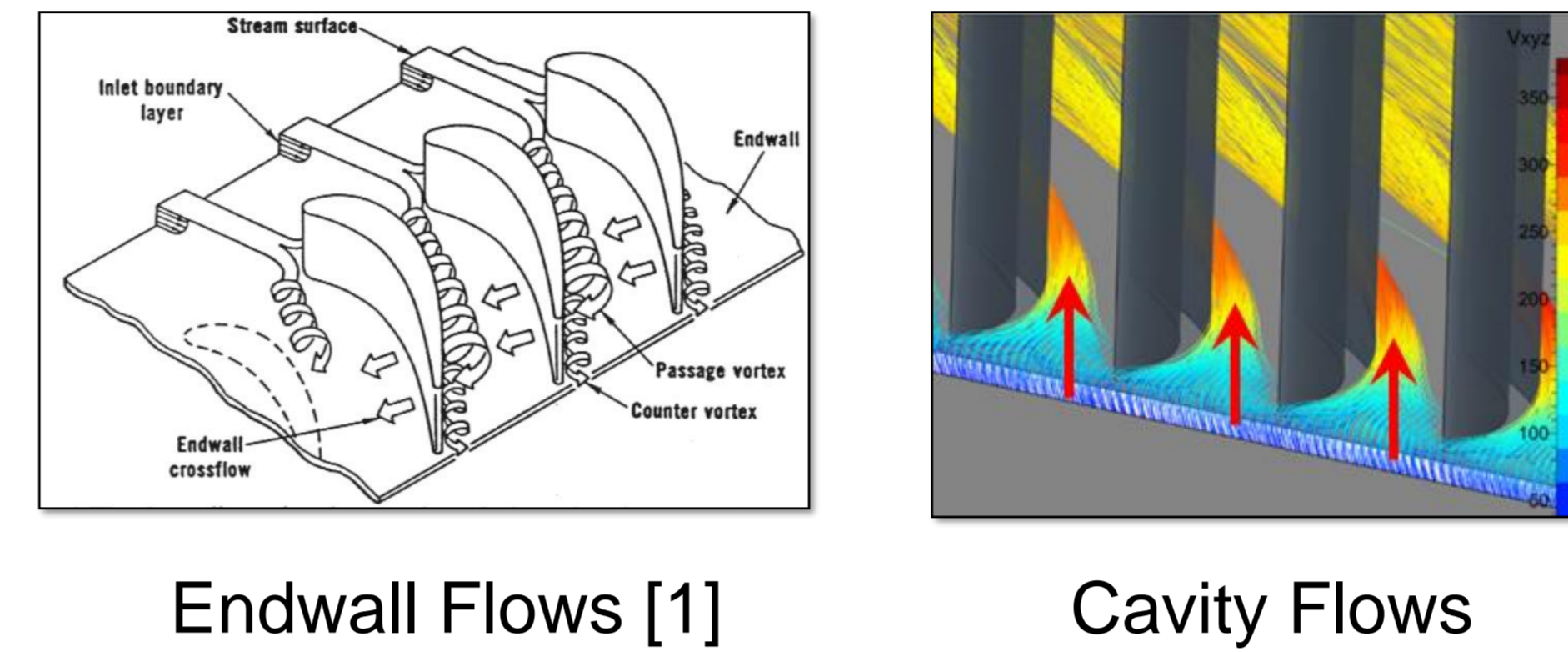

Focus of the project

- Unsteady interaction between wakes and combined losses impact on High-Speed LPT
- Open-access experimental database of High-Speed LPT at engine representative conditions
- Innovative technologies to reduce secondary losses



SPLEEN
Secondary and Leakage Flow Effects in High-Speed Low Pressure Turbines

- Setup, Integrate and Test a HS LPT module in a multi-row rotating environment at engine representative conditions
- Impact on performances of :
 1. Endwall flows
 2. Cavity purge flows
 3. Leakage driven flows
- Cavity unsteady aerodynamics
- Impact of cavity shape on performances
- Impact of purge flow rates

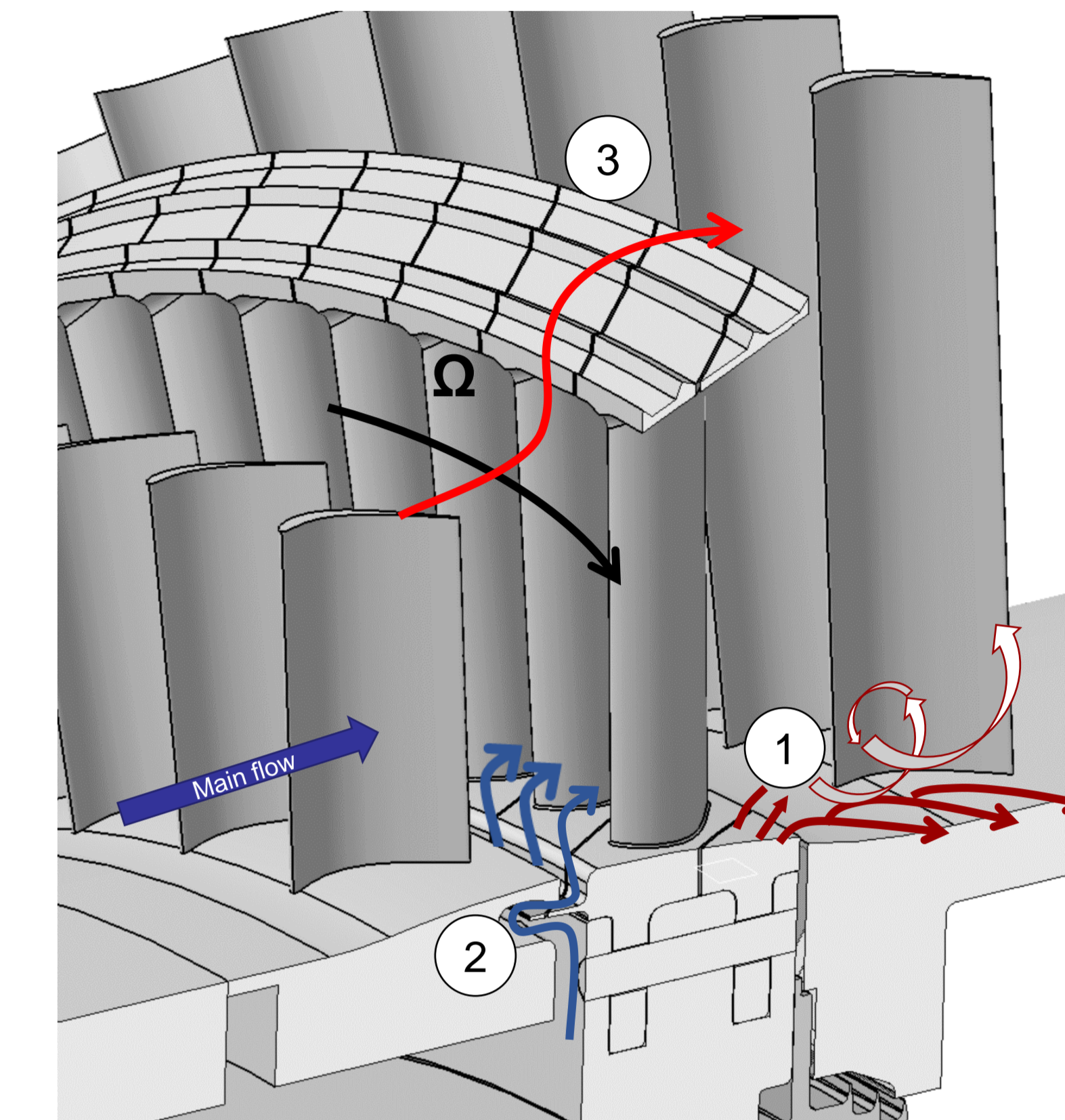

Experimental Approach and Setup

Steady/Unsteady Measurements

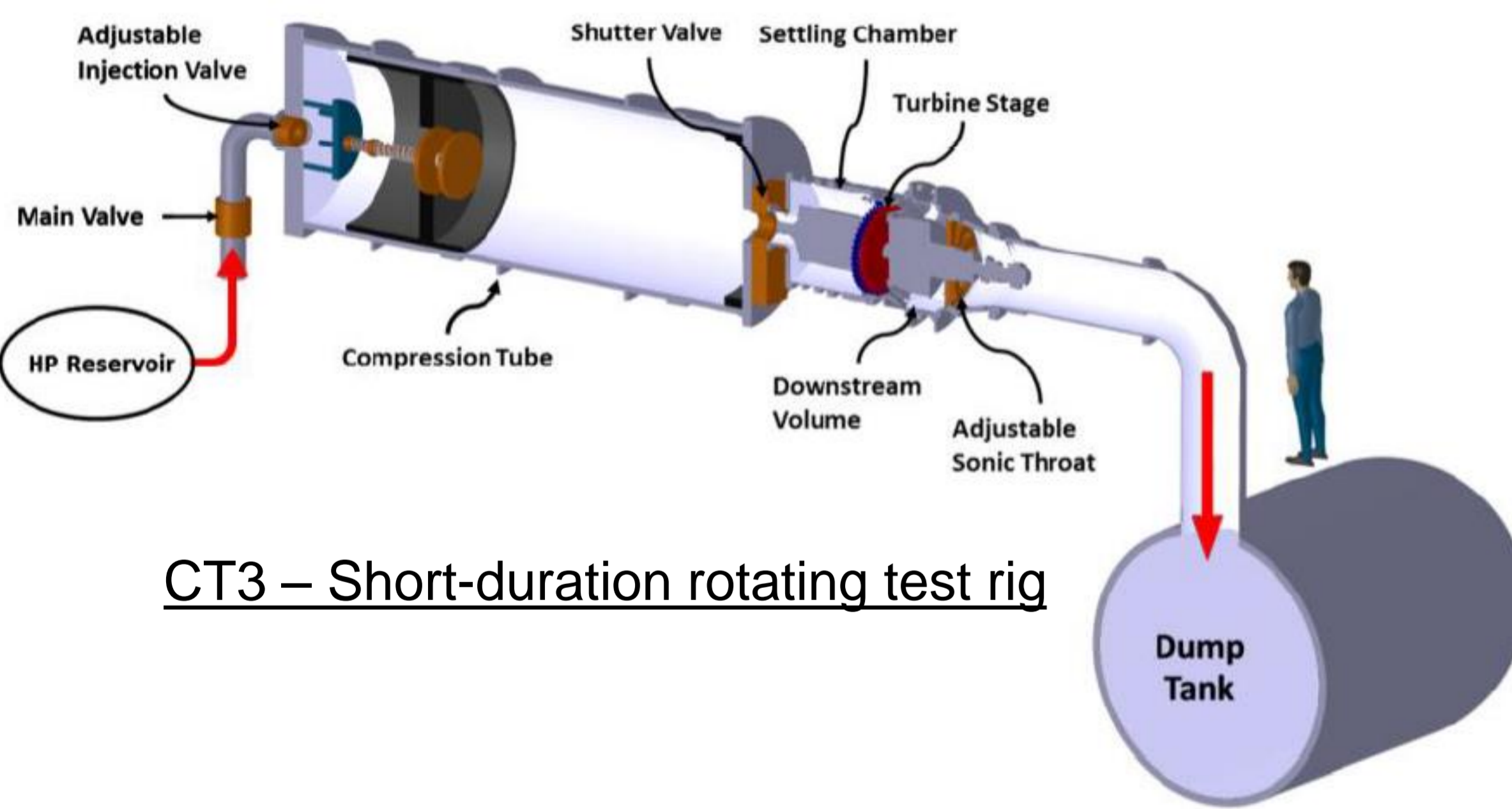

CT3 – Short-duration rotating test rig

VKI turbine rig commissioned for testing of full scale LPT stage

- Short duration
- Transonic Mach numbers
- 1.5 stage High-Speed Low-Pressure Turbine with purge flows
- Design (VKI-Safran Aero Engines) of a Research Turbine

Effect of cavity geometries

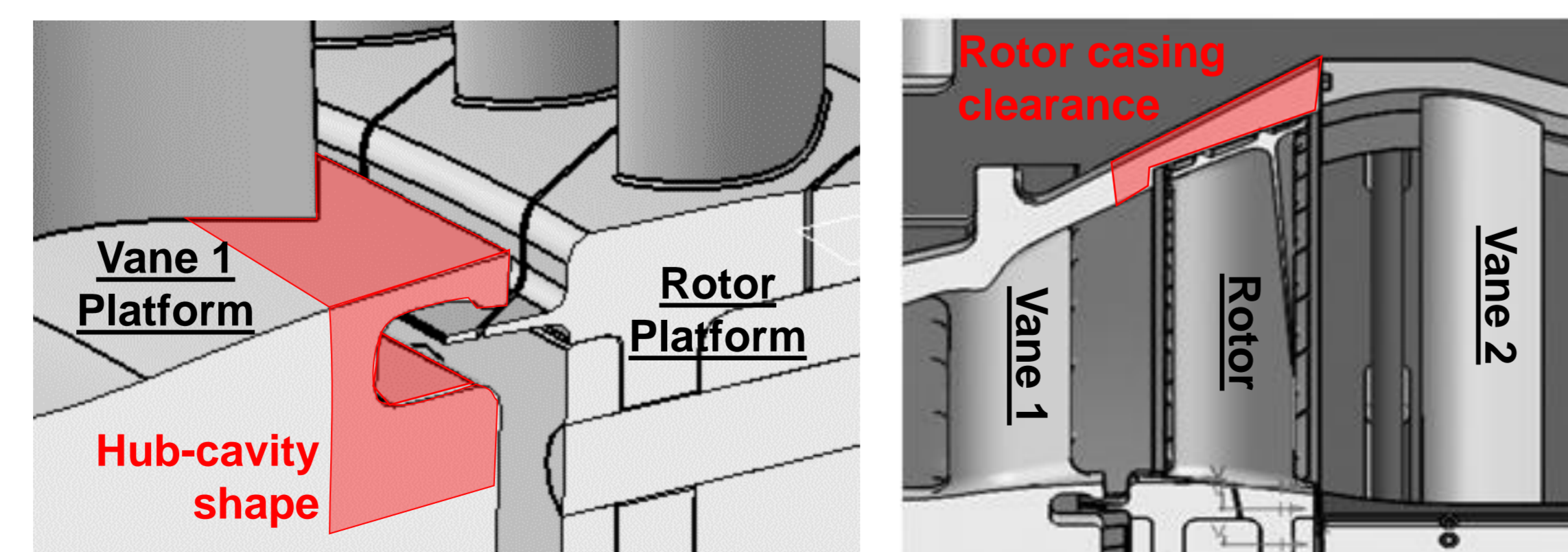

Off design testing

- Off design pressure ratio
- Off design purge flow rates

Full characterization of inlet conditions

- Total Pressure
- Total Temperature
- Turbulent Intensity and Length Scale



Rotor-casing and near tip Aerodynamics

- Static Pressure

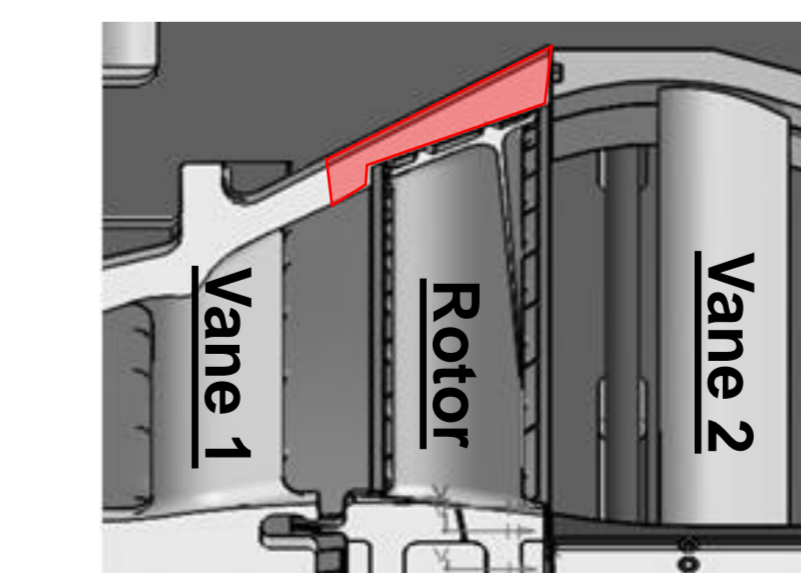

- PSP and cooling effectiveness by foreign gas

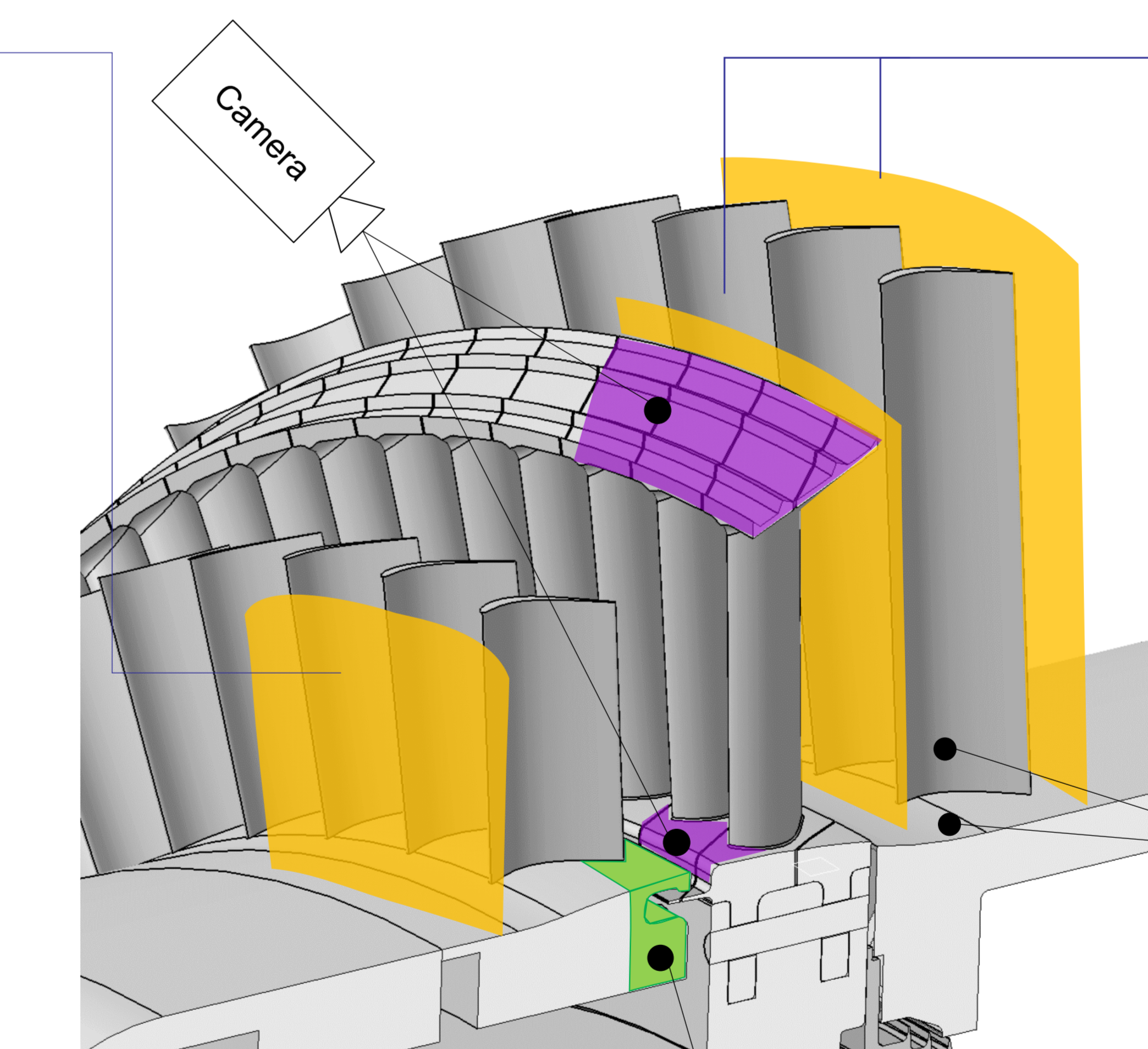

Time-Resolved R1&V2 Outlet flow quantities

- Pressure, Mach and Angles

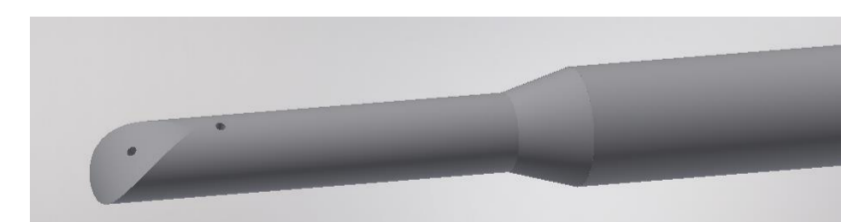

- Temperature



Endwall and Airfoil Aerodynamics

- Static pressure

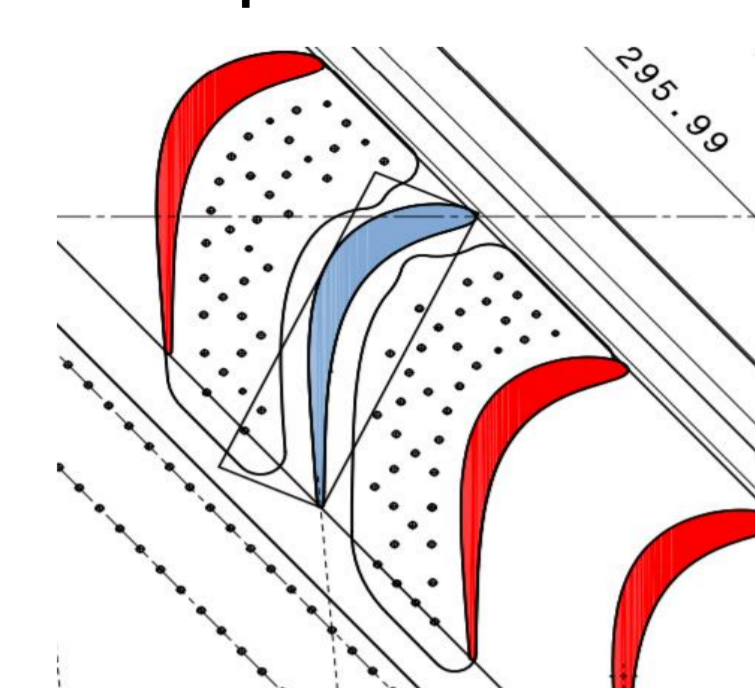

Cavity Aero-Thermodynamics

- Static Pressure
- Heat-transfer
- PSP and cooling effectiveness by foreign gas

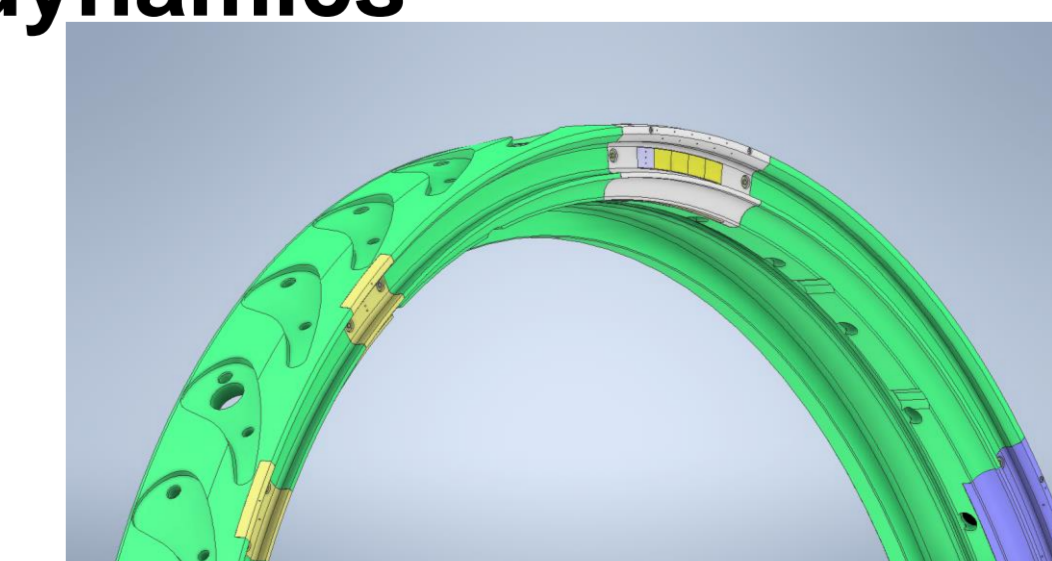

Acknowledgments

The authors gratefully acknowledge funding of the SPLEEN project by the Clean Sky 2 Joint Undertaking under the European Union's Horizon 2020 research and innovation programme under the grant agreement 820883

References

[1] Langston, L.; Secondary Flows in Axial Turbines – A Review; Annals New York Academy of Sciences, May 2001