

Improving TSO-DSO Coordination Through Dynamic Operating Envelopes Allocation

Anthony Maio, Thomas Richard, Maurizio Vassallo, Adrien Bolland, Vincent Barbesant,
Julien Callec, Sébastien Haye, Dorian Fourniret et Damien Ernst

Motivation

More prosumers, BESSs, and non-dispatchable energy sources connected to the network



The network becomes difficult to operate, with recurrent voltage deviations



Traditional methods either fail to guarantee security or are complex

The voltage profile should be optimized at all network levels.

Improvements in the coordination between TSOs and DSOs are required.

A solution is to decouple grid operations while maintaining network security.

Fit and Forget: accommodate static worst-case consumption scenarios.

Active Network Management (ANM): dynamically curtail PV injections, coordinate flexible loads, ...

Approach	Security	Efficiency
Fit & Forget	✗	✗
ANM	✓	✓
DOEs	✓	✓

Graph-based formalism: definitions

DOE – Dynamic Operating Envelope

 Power exchanged limits

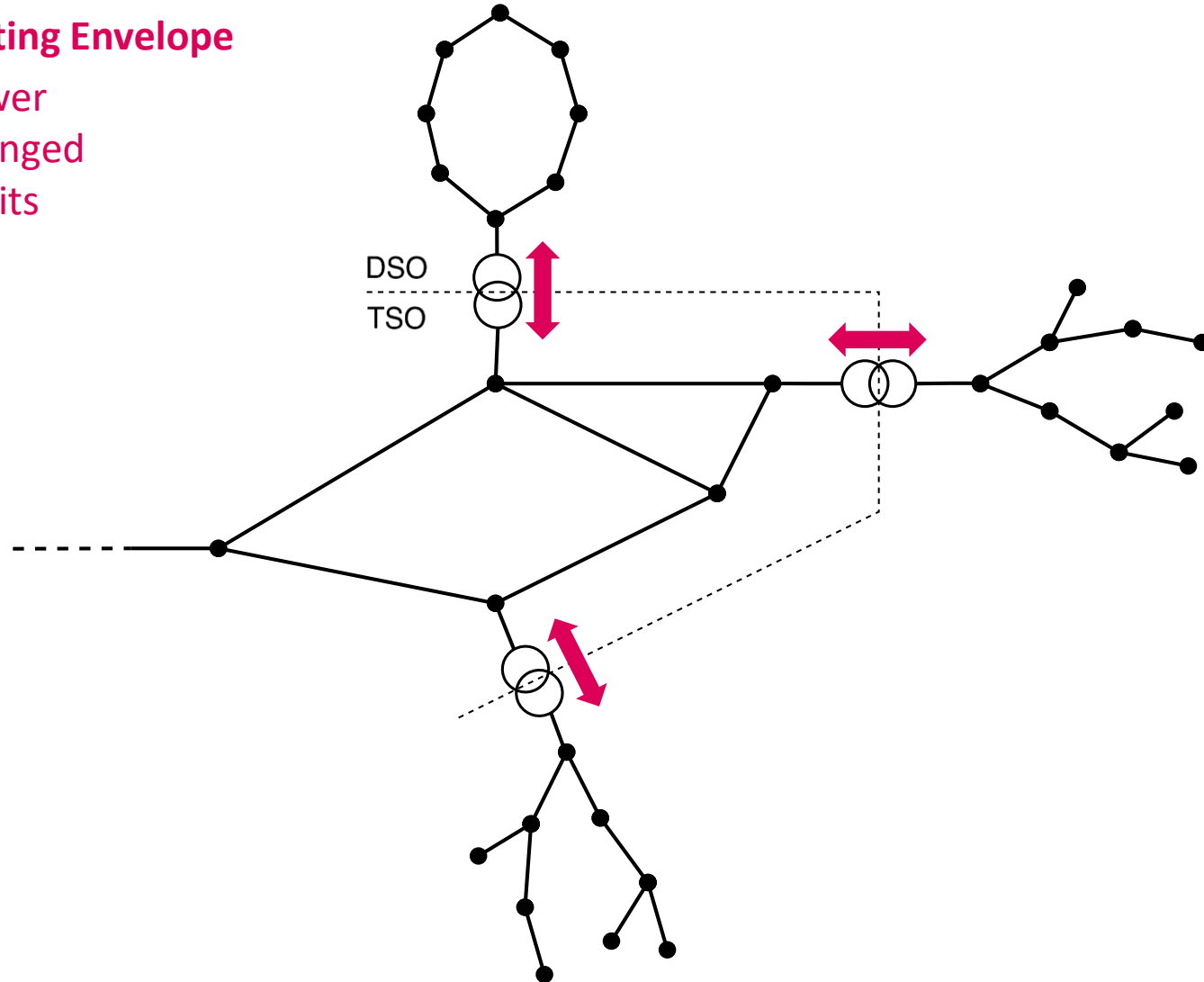

Graph-based formalism: definitions (2)

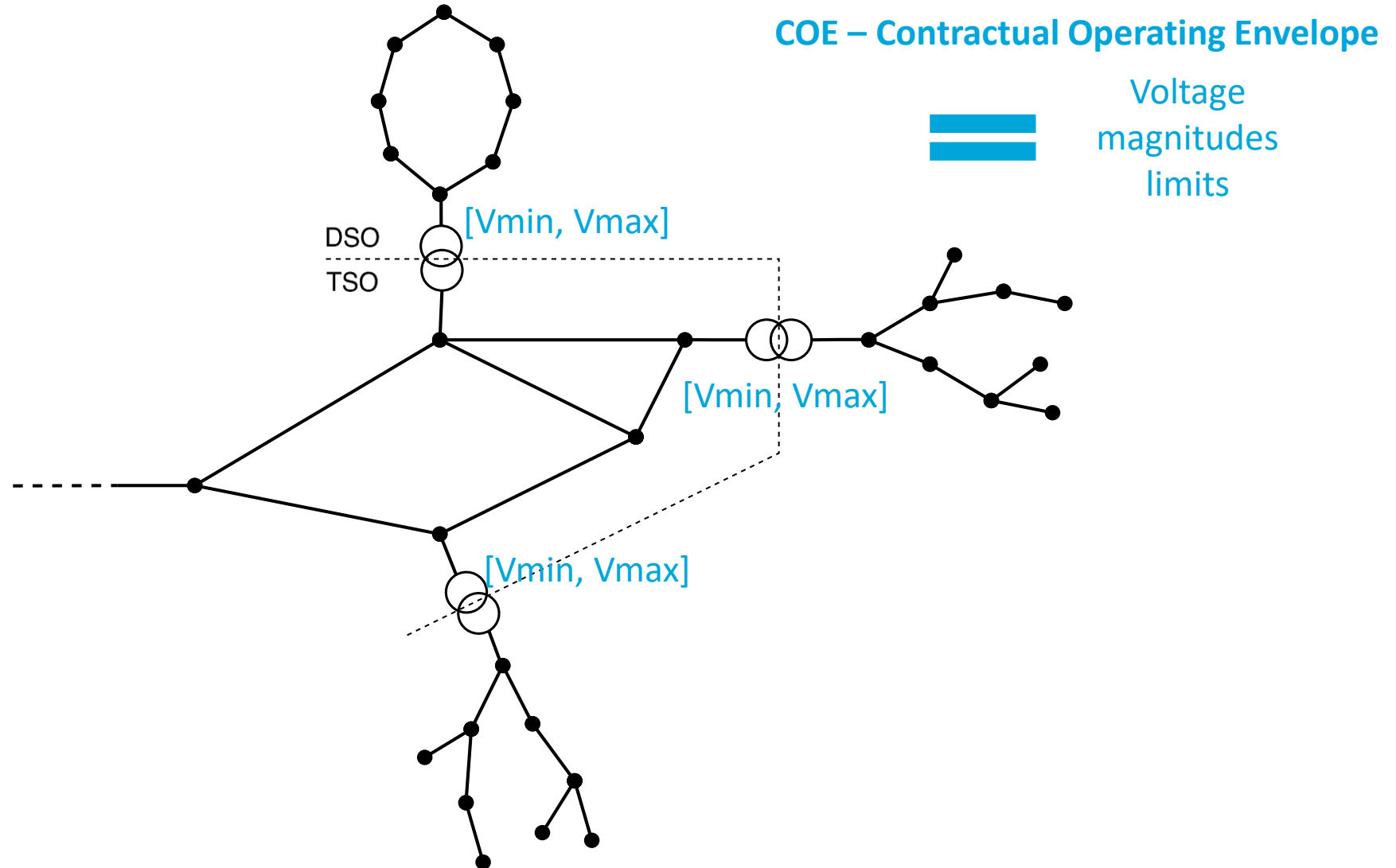

Real-life implementation: sequence

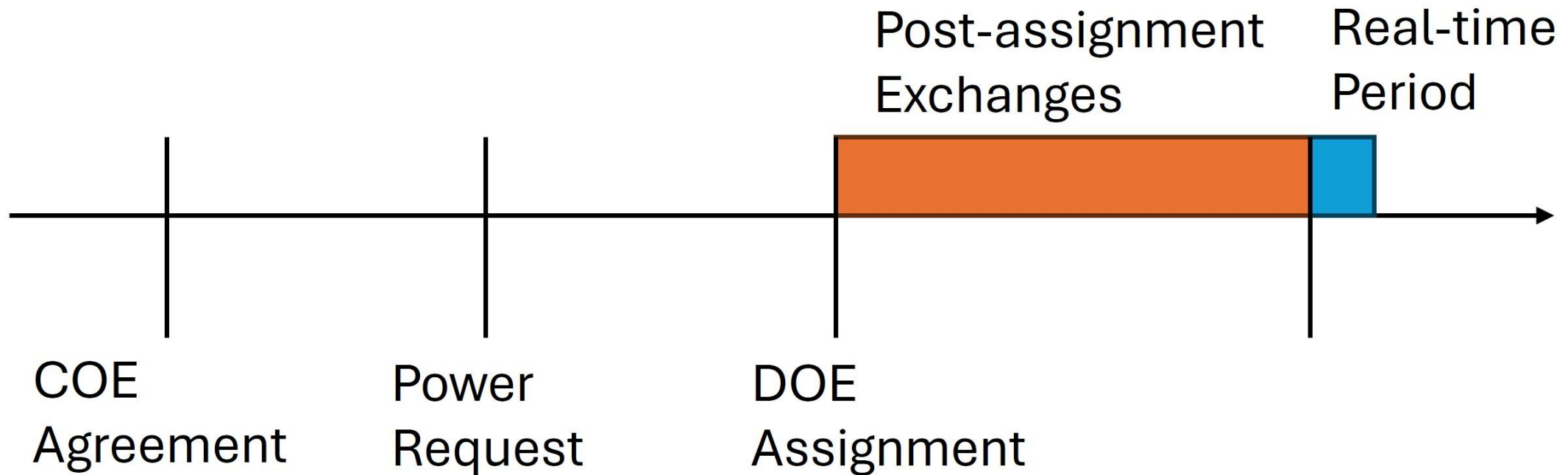

Real-life implementation: sequence

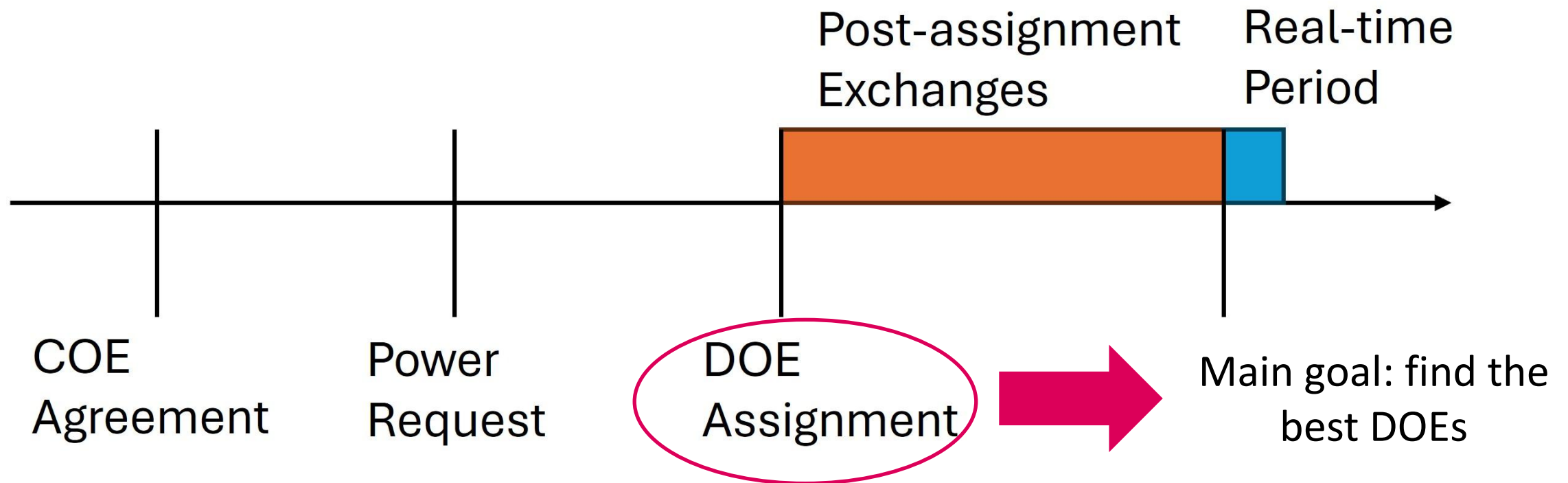

Optimization problem: an overview

$$\max_{\bar{S}^c, A} U^{DOE}(\bar{S}^c, A, S'^o) \quad \text{e.g., DOEs size} \quad (1a)$$

$$\text{s.t. } \forall S^{-,c} \in \bar{S}^c, \forall V^p \in \bar{V}^p : \quad (1b)$$

$$Security(S^o, S^{-,c}, V^p, \bar{V}^c, \bar{S}^p) \leq 0 \quad (1c)$$

$$Cost(S^o, S^{-,c}, V^p, \bar{V}^c, \bar{S}^p) \leq A \quad (1d)$$

Application to a test network: results

