

Model-based Patient Matching for in-parallel Multiplexing Mechanical Ventilation Support

Jin Wai Wong*, Yeong Shiong Chiew*, Thomas Desaive**, J. Geoffrey Chase***

* School of Engineering, Monash University Malaysia, Selangor, Malaysia (e-mail: chiew.yeong.shiong@monash.edu)

** GIGA-In Silico Medicine, University of Liege, Liege, Belgium (e-mail: tdesaive@uliege.be)

*** Centre for Bioengineering, University of Canterbury, Christchurch, New Zealand (email: geoff.chase@canterbury.ac.nz)

Abstract: Surges of COVID-19 infections could lead to insufficient supply of mechanical ventilators, and rationing of needed care. Multiplexing mechanical ventilators (co-MV) to serve multiple patients is a potential temporary solution. However, if patients are ventilated in parallel ventilation, there is currently no means to match ventilation requirements or patients, with no guidelines to date for co-MV. This research uses patient-specific clinically validated respiratory mechanics models to propose a method for patient matching and mechanical ventilator settings for two-patient co-MV under pressure control mode. The proposed method can simulate and estimate the resultant tidal volume of different combinations of co-ventilated patients. With both patients fulfilling the specified constraint under similar ventilation settings, the actual mechanical ventilator settings for co-MV are determined. This method allows clinicians to analyze in silico co-MV before clinical implementation.

Copyright © 2021 The Authors. This is an open access article under the CC BY-NC-ND license (<https://creativecommons.org/licenses/by-nc-nd/4.0/>)

Keywords: Parallel ventilation, co-ventilation, decision support, model-based method.

1. INTRODUCTION

Surges of COVID-19 infections prompted extreme demand for mechanical ventilation (MV), as 30% of hospitalised COVID-19 patients may require ventilator support (Penarredonda, 2020). Long lengths of MV means hospitals may see shortfalls in ventilators, leading to rationing of care and significant clinical stress (Truog et al., 2020). One potential solution is to multiplex MV to two or more patients simultaneously.

Multiplexing patients in-parallel, where patients breathe together, has been tested experimentally (Neyman and Irvin, 2006, Paladino et al., 2008, Smith and Brown, 2009) and clinically (Beitler et al., 2020). However, in-parallel co-ventilation (co-MV) can offer significant risks due to the inability to individualise MV settings and monitor the personal condition of each patient during multiplex ventilation (SCCM et al., 2020), increasing risk to patients (Chase et al., 2020a).

Nevertheless, dual-ventilation setups have been proposed (de Jongh et al., 2020, Clarke et al., 2020, Han et al., 2020, Srinivasan et al., 2020, Chase et al., 2020a). However, only one offers the ability to personalise settings, and requires a low-cost servo-mechanism to control breathing in-series (one after the other) to meet criticisms of international critical care societies (Chase et al., 2020b).

In particular, the technically simpler in-parallel approaches cannot compensate for variability in patient-specific lung elastance, which varies over the course of disease (Branson et al., 2012, van Drunen et al., 2014). To date, no published studies can provide an easily implemented and general guideline for patient matching in in-parallel co-MV. This study presents a model-based approach to help guide clinical

decision-making in matching patients for co-MV, at least over short periods of time before patient state changes.

2. METHODOLOGY

2.1 Setting up for Co-Ventilation (co-MV)

Patient-specific respiratory mechanics, including airway resistance (R) and lung elastance (E) provide information on patient-specific response to MV. Thus, to set up co-MV, a patient must first be ventilated to obtain the corresponding respiratory mechanics. These values can be identified from measured airway pressure and flow (Chiew et al., 2011). Forward simulation using a clinically validated single-compartment linear lung model (SCM) (Chiew et al., 2011) can then assist clinicians in selecting the most compatible second patient for co-MV. In particular, further simulation using a double-compartment linear lung model (DCM) is used to determine the best co-MV settings for two specific patients. Fig. 1. and Fig. 2 show the sample setup for multiplex ventilation and equivalent mathematical models (SCM and DCM) (Bates, 2009) to represent the parallel multiplex ventilation setup.

2.2 Mechanical Ventilator Settings

Fundamentally, MV can be delivered invasively and non-invasively. In our case, we focus on invasive respiratory support where the patient is intubated. For multiplex ventilation, random trigger efforts from either patient will lead to alarms and ventilatory compromise due to the chaos invoke in ventilatory pattern (Chatburn et al., 2020). Therefore, patients must be completely sedated during co-MV. In response to that, pressure control (PC) mode is used in this study to fully assist the patient in respiratory process by controlling the input and output of the airway pressure.

Key co-MV parameters include respiratory rate (RR), the ratio of inspiration time to expiration time ($I:E$), and the positive end-expiratory pressure (PEEP). Pressure control (PC) mode strictly limits peak inspiratory pressure (PIP), but cannot control peak inspiratory volume so there is still risk of VILI (Major et al., 2018). Table 1 shows a set of lung protective strategy MV settings based on several studies. In PC mode, PIP is typically set where plateau pressure (P_{PLAT}) is less than 30-35 cmH₂O.

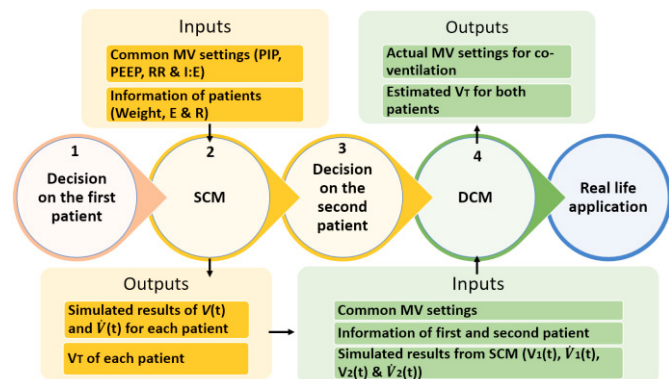

Fig. 1. Flow chart of the protocol stages for co-MV.

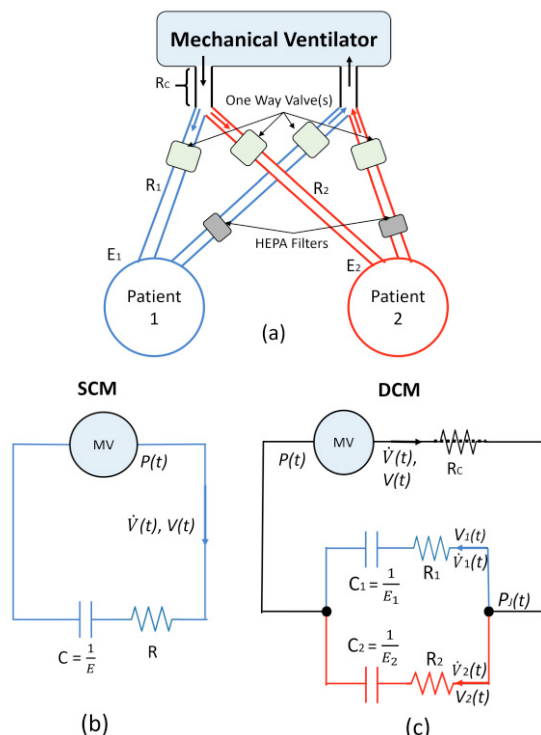

Fig. 2. Basic setup for multiplex ventilation (a), and the equivalent mathematical model for SCM (b) and DCM (c). The parameter descriptions are detailed in Section 2.3.

Table 1. Recommended MV settings from literature

Parameters	Criteria	References
P_{PLAT}	< 35 cm H ₂ O	(Gattinoni et al., 2006)
PEEP	5-25 cm H ₂ O	(Gattinoni et al., 2017)
RR	12-20 bpm	(O'Driscoll et al., 2017)
$I:E$	1:2 – 1:5	(Poor, 2018)
V_T	6-8 mL/ kg	(The Acute Respiratory Distress Syndrome Network, 2000)

The major concern of in-parallel co-MV in PC mode is the shared tidal volume (V_T) delivered. This distribution of V_T depends solely on the respiratory mechanics, and patients with different respiratory mechanics will receive different V_T in proportion. Thus, patients with differing elastance may not receive V_T within the goal 6-8 mL/kg range.

2.3 Lung Compartment Models

The mathematical model of a single patient MV circuit can be represented by an electrical circuit (Bates, 2009):

$$P(t) = RV(t) + E\dot{V}(t) + P_0 \quad (1)$$

Where airway pressure $P(t)$ is controlled in PC mode, and volume, $V(t)$, and flow, $\dot{V}(t)$, are measured to identify elastance, E , and resistance, R , and positive end expiratory pressure (PEEP) is P_0 . This equation is shown in Fig. 2(b), and the repeated DCM version is in Fig. 2(c), where the second patient shares the input pressure. In the electrical circuit, Compliance (C) is inverse of Elastance (E). The parallel circuit for co-MV with a second patient is thus defined:

$$\begin{aligned} (R_1 + R_2)\dot{P}(t) + (E_1 + E_2)P(t) \\ = [R_1R_2 + R_c(R_1 + R_2)]\dot{V}(t) \\ + [(R_c + R_2)E_1 + (R_c + R_1)E_2]\dot{V}(t) + E_1E_2V(t) \end{aligned} \quad (2)$$

Where Patient 1 and Patient 2 are defined in terms of their patient-specific lung mechanics (E_1, E_2, R_1, R_2) and resulting patient-specific flow and volume ($V_1(t), \dot{V}_1(t), V_2(t), \dot{V}_2(t)$) using subscripts, and are seen in the blue and red paths in Fig. 2(c). R_c is the common resistance component due to ventilation circuit where it is shared during co-MV. P_j is the pressure at the joint connecting both patients during co-MV. Equation (2) can be solved to obtain the resulting behaviour, where all simulations are performed using MATLAB 2019 (Natick, MA).

2.4 Simulation of Virtual Ventilation

The proposed pairing process is assessed in virtual patient simulations (Chase et al., 2018, Arunachalam et al., 2020). In this manuscript, we demonstrate the pairing process using a simulated Patient (Patient 1). 5 additional virtual patients with different respiratory mechanics are assigned as the potential candidates for co-MV. Their suitability are evaluated using model-based predicted tidal volume (in mL/kg) corresponding to patient-specific respiratory mechanics and weights. To ensure the patient-specific values of E and R are realistic, they are chosen based on the values proposed by Arnal et al. (2018).

Table 2 shows Patient 1's respiratory mechanics and the corresponding PC mode MV settings that the patient is ventilated in. Table 3 shows the respiratory mechanics of the 5 potential virtual patients that can be co-MV with Patient 1. The patient's respiratory mechanics were set based on different levels of respiratory failure where Increasing respiratory failure results in greater elastance, and obstructive disorders have greater resistance. In this study, the mean values of the patient's respiratory system elastance and resistance are used.

Table 2. Patient 1 respiratory mechanics and MV settings

Patient	Respiratory Failure	E (cmH ₂ O/L)	R (cmH ₂ Os/L)	Weight (kg)
1	Mild	20 (18-27)*	10 (9-14)*	65

*Mean (range)

MV Settings	
PIP (cmH ₂ O)	17
PEEP (cmH ₂ O)	7
RR (bpm)	15
I:E	1:2

Table 3. Potential patients to be co-MV with Patient 1

Patient	Respiratory Failure	E (cmH ₂ O/L)	R (cmH ₂ Os/L)	Weight (kg)
A	Normal	18 (15-22)	12 (10-15)	50
B	Moderate	25 (20-32)	12 (10-14)	65
C	Mild	18 (18-27)	9 (9-14)	80
D	Obstructive	15 (13-23)	22 (16-33)	65
E	Severe	30 (22-33)	11 (9-14)	100

Patient 1 with mild respiratory failure, is the first patient ventilated, with Patients A-E being potential matches. With the common MV setting and the information of each patient, simulation is used with Equation (1) to select the second patient from Patients A to E. In addition, for a more general solution, values of E and R within the range of 1 to 50 will be simulated for the second patient to assess where a best patient match might lie. After selecting the second patient, the final step is to simulate the actual MV setting by using DCM model. The feasibility of the actual MV setting will be evaluated by comparing the percentage difference of V_T .

3. RESULTS

3.1 Pairing Patient Selection

Simulated data obtained from Equation (1) is presented in Resistance-Elastance tidal volume contour plots (R - E plot) in Fig. 3, showing the distribution of V_T based on different lung mechanics using the MV settings shown in Table 2. Fig. 3(a) shows the R - E contour plot for patient weighing at 50 kg, Fig. 3(b) at 75 kg and Fig. 3(c) at 100kg. The green zone is a safe zone for co-MV where V_T falls in the 6-8 mL/kg. The gradual change from green-to-yellow, yellow-to-orange, and orange-to-red zones represent changes from $V_T = 6-8$ mL/kg to higher tidal volume (moving towards bottom left), or to lower tidal volume (moving towards upper right). Fig. 3 also shows that the region of 6-8 mL/kg (center green) reduces if a patient weight increases. For a 100 kg patient in Fig 3(c), the ranges

of patient-specific E and R for co-MV with Patient 1 are highly restricted. At low resistance, the curve is nearly vertical as the change in V_T is primarily a function of elastance when R is low. As R increases, V_T is more sensitive, as this term in Equation (1) plays a greater role. Thus, the R - E contour plots are not only MV setting-specific, but it is also weight-specific.

Fig. 4(a)-(d) show the contour plots for patient weights at 50 kg, 65 kg, 85 kg and 100 kg. The patients in Tables 2 and 3 are indicated in their respective weight-specific R - E plot. The V_T for each patient in Tables 2 and 3 is presented using their corresponding weight. The MV setting for mild respiratory failure patient is not suitable for a healthy patient with a weight of 50 kg as the V_T of Patient A exceeds 8 mL/kg. Based on Fig. 4(b), the resultant V_T of Patient 1 is ~ 6.99 mL/kg, and the V_T of Patients B and D fall outside the green region. For Patient B with moderate respiratory failure, the lungs are stiffer than Patient 1, shifting them to the right. Equally, Patient D with significantly higher resistance has shifted upwards from Patient 1. Similar for Patients B and D, higher inspiratory pressure is required to increase the volume of delivered air to the lungs. Fig. 4(d) shows Patient E falls in the orange zone and should be eliminated from co-MV candidates. In this case study, the ideal patient to be paired with Patient 1 is Patient C as shown in Fig. 4(c) with estimated V_T of ~ 6.31 mL/kg when delivered with the same MV settings.

3.3 Recommended MV Settings

With a final decision on pairing, the DCM is simulated to obtain MV settings for co-MV. An arbitrary value of 8 cmH₂Os/L is assigned to R_c of the multiplex ventilation circuit. The ideal graphs (dotted line) representing the initial inputs ($P_I(t)$, $\dot{V}_I(t)$, $\dot{V}_2(t)$, $V_I(t)$, $V_2(t)$) computed from SCM are shown in Fig. 5.

The ideal $P_I(t)$ represents the pressure graph generated from MV based on the setting in Table 2. Positive flow rate indicates air entering the lungs during inspiration, whereas negative flow rate indicates the exiting air flow during expiration. Due to the existence of R_c , the resultant solution for $P(t)$ has appeared to be a ramp waveform (green dotted line) as shown in Fig. 5(a). Theoretically, the ideal results can be obtained by generating a similar pressure graph. Unfortunately, modern PC model MV only generates square wave pressure. It is also implausible to apply a negative airway pressure. Thus, to ensure sufficient V_T is delivered, the main factor to be considered is to adjust the inspiratory pressure generated from the ventilator.

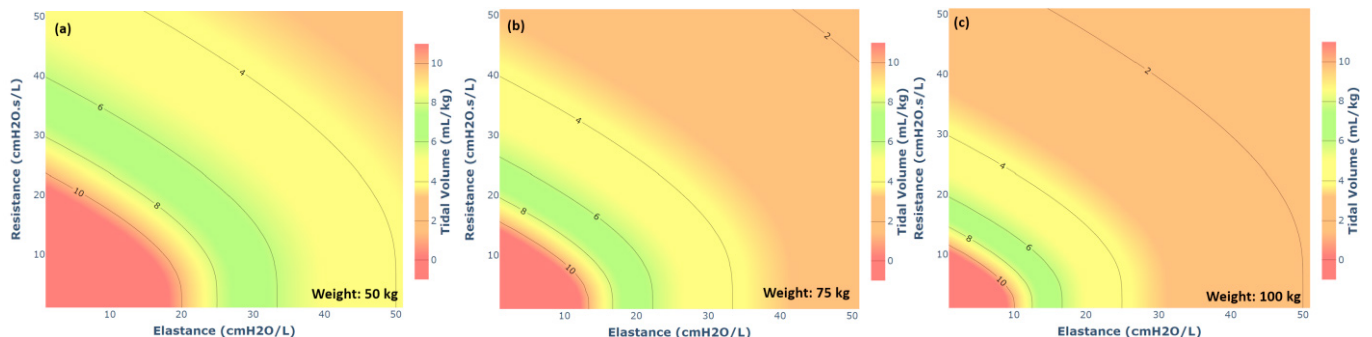

Fig. 3. Resistance-Elastance tidal volume contour plots for patient's weight at 50 kg (a), 75 kg (b), and 100 kg (c).

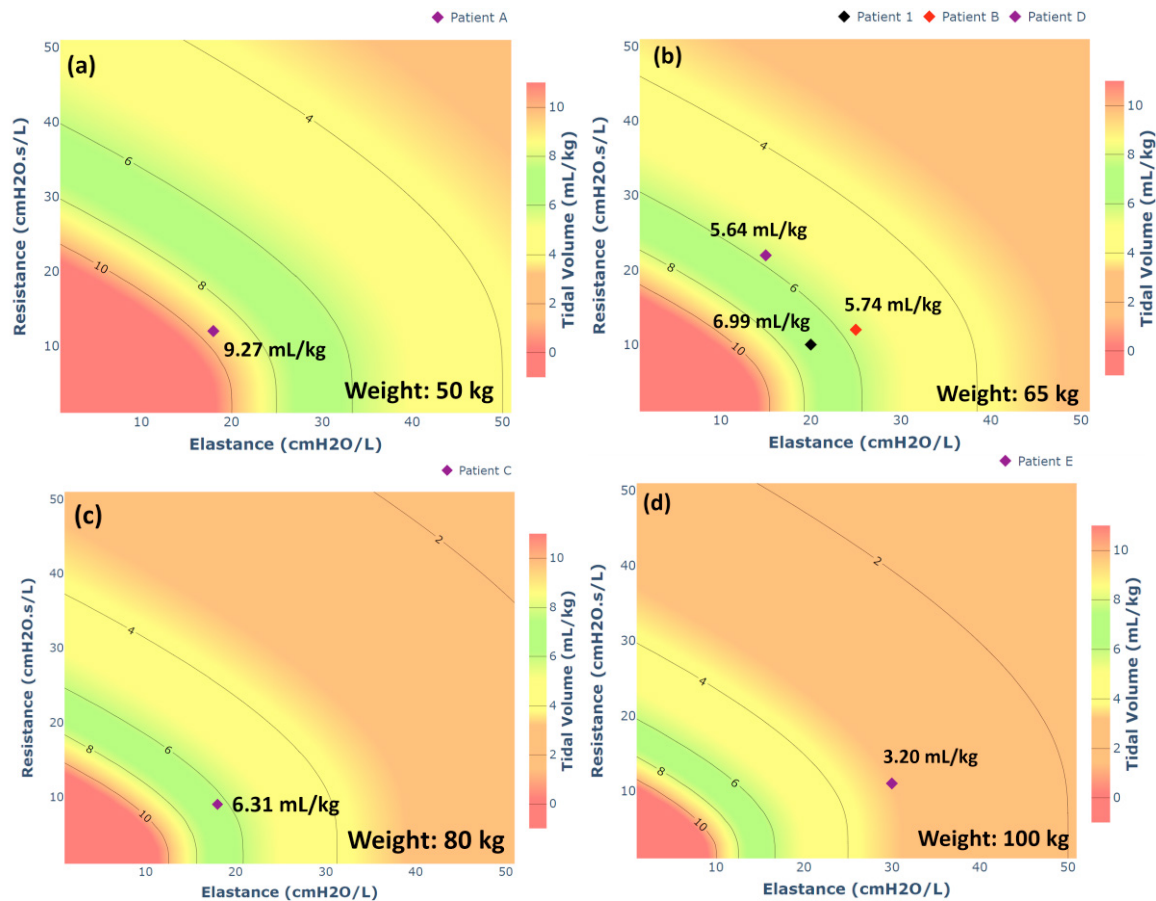

Fig. 4. Resistance-Elastance tidal volume contour plots for patient with 50 kg (a), 65 kg (b), 80 kg (c), and 100 kg (d). The estimated tidal volume for Patient 1, A, B, C, D and E are indicated in the respective weight-specific R-E plot.

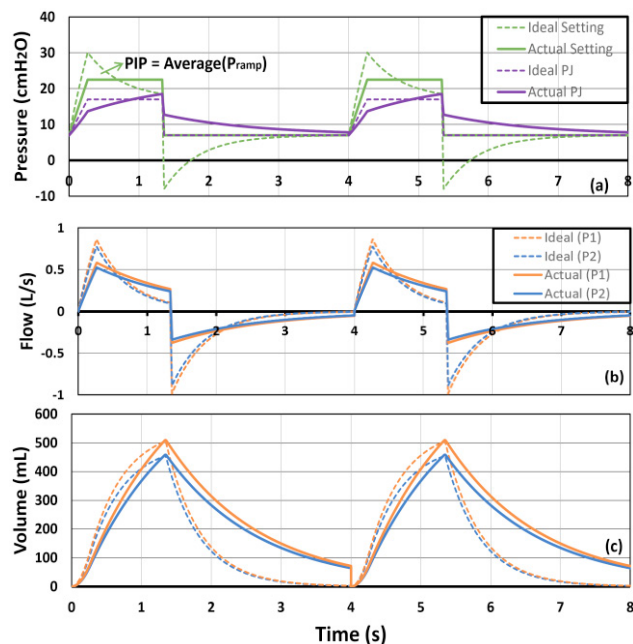

Fig. 5. Comparison between ideal results and actual results for two breathing cycles.

In this study, the inspiratory pressure is controlled by changing the PIP while keeping the PEEP constant. Based on the ideal $P(t)$, PIP is estimated by taking the average pressure from the ramp section (P_{ramp}) as shown in Fig. 5(a). This approach will typically lead to a lower V_T compared to ideal values. In

response, the final MV setting is obtained through an iterative process. The value of PIP obtained from the average P_{ramp} is increased by 0.5 cmH₂O for each simulation iteration before a V_T with minimum error is obtained. Fig. 5(a) shows the finalised actual MV setting for co-MV (green solid line). Based on the finalised MV setting, PIP has increased to 22.5 cmH₂O, which is 5.5 cmH₂O higher than the initial MV setting. The inspiratory pressure required to deliver the desired V_T to each patient is 15.5 cmH₂O. As a result, $P_J(t)$ is no longer a perfect square wave (purple solid line). Comparing with the ideal P_J in Fig. 5(a), the actual P_J has a higher PIP.

The peak flow rate in Fig. 5(b) shows a significant decrease compared to the ideal flow. Nonetheless, the subsequent decreasing rate of the actual air flow is lower thus ensuring sufficient air is delivered to the lungs. From Fig. 5(c), the ideal V_T is 454.2 mL whereas the actual V_T is 458.5 mL, which is a negligible difference at 0.86% error. For the result of Patient C, the ideal and the actual V_T are also very close at 0.95% error. The summarised results of V_T in mL/kg are shown in Table 4.

Table 4. Results of V_T for Patients under co-MV

	Patient 1	Patient C
Ideal V_T (mL/kg)	6.99	6.31
Actual V_T (mL/kg)	7.05	6.37
Percentage Error (%)	0.86	0.95

4. DISCUSSION

4.1 General Implementation

The proposed protocol has demonstrated successful patient matching and MV setting in a model-based simulation. Apart from finding the suitable pair of patients, further noteworthy information can be obtained from this pairing process. First, due to the highly restrictive respiratory mechanics, obese patients have to be singly ventilated with extra care. This result was not noted in any prior simulation studies, nor in the one clinical case study done (Beitler et al., 2020), and represents a major risk given rising obesity rates, and the greater risk during COVID-19 for patients with this comorbidity.

Next, to decrease tidal volume, increasing the airway resistance can shift the V_T of Patient A higher so it falls within the green zone. This resistance can be achieved by inserting an adjustable resistor in the inspiratory tube. The added resistor component, will thus lower the amount of tidal volume entering to Patient A. However, in this study a comparison between a healthy patient and a patient with respiratory failure is done for theoretical and illustrative purposes only.

Aside from providing the estimated V_T , the R - E contour plots can provide insights for the clinicians to evaluate the subsequent effects of co-MV. For instance, if Patient 1 has clinically improved during the process of co-MV and the value of E drops to 15 cmH₂O/L, their V_T is now out of the green zone and might place both patients at risk. With this foreseeable situation, the clinician can be given an alternative to install an adjustable resistor in the inspiratory path of Patient 1. Such resistors can be placed in the respiratory circuit at the start and left at very low or zero value until needed.

4.2 Limitations, Future Implications and Work

Clinicians are able to virtually preview the results of co-MV by pairing patients in a virtual environment. Similar to the DCM model, different settings can be tested virtually without causing harm. Nevertheless, this study is completed by implementing a purely mathematical model. Experiments must be performed in vitro, followed by animal and/or clinical studies to further validate the efficacy and safety of the proposed model.

More factors should be considered in real-life application. For instance, one patient might need a higher fraction of inspired oxygen (FiO₂) to increase oxygenation when collapsed alveoli are not recruitable, which is not possible with either in-parallel or in-series co-MV. The proposed model is unable to provide the adjustment required for the remaining MV parameters other than inspiratory pressure during co-MV.

Equally, patient-specific parameters are likely to diverge over time as the disease progresses differently for each patient. Such inter- and intra- patient variability is a major concern in any form of MV (van Drunen et al., 2013, Morton et al., 2019). To overcome the inconsistencies of respiratory system mechanics, the proposed method can be implemented in a closed-loop system capable of monitoring the health conditions of the co-MV patients in real-time (Szlavetz et al., 2014, Rees, 2011, Ng et al., 2020, Ng et al., 2021). Equally, in-series approaches, which would also benefit from patient

matching, could be used where each patient has a unique inspiratory circuit and control (Chase et al., 2020b).

Clinically, although the proposed method has demonstrated the ability to assist clinicians during co-MV, multiplexing MV should only be treated as a temporary solution and last resort during health crisis (Chase et al., 2020a). Thus, any use of this ventilation approach should be restricted or held for short term MV until more capacity can be found. Equally, COVID-19 and respiratory failure patients could be avoided for co-MV, where more stable patients requiring MV could be matched, thus reducing some of the potential issues with variability.

5. CONCLUSIONS

Deciding the patients for multiplex ventilation is a complex and stressful process. The model-based approach presented in this study could be served as a guideline to determine a pair of patients and the corresponding MV settings for multiplex ventilation. By having preliminary results prior to practical application, the risk of causing catastrophic complications and VILI can be decreased significantly. Nevertheless, additional clinical trials are required for further validations.

ACKNOWLEDGEMENT

The authors would like to thank the Ministry of Energy, Science, Technology, Environment and Climate Change (MESTECC) research grant (IF0219I1060), MedTech Centre of Research Expertise, University of Canterbury, New Zealand, the New Zealand Ministry of Business Innovation and Employment (MBIE) Covid Innovation Action Fund (CIAF), and Monash University Malaysia Advance Engineering Platform (AEP) for supporting this research. We also like to thank WX Ting, S Azlan Shah, Jay WW Lee, QA Ng, G. Arunachalam and NL Loo for contributing to this work.

REFERENCES

- Arnal, J.-M., Garnero, A., Saoli, M. & Chatburn, R. L. 2018. Parameters for Simulation of Adult Subjects During Mechanical Ventilation. *Respiratory Care*, 63, 158-168.
- Arunachalam, G. R., Chiew, Y. S., Tan, C. P., Ralib, A. M. & Mat Nor, M. B. 2020. Virtual Mechanical Ventilation Protocol – A Model-based Method To determine MV Settings. *IFAC-PapersOnLine*, 53, 16119-16124.
- Bates, J. H. 2009. *Lung mechanics: an inverse modeling approach*, Cambridge University Press.
- Beitler, J. R., Mittel, A. M., Kallet, R., Kacmarek, R., Hess, D., Branson, R., Olson, M., Garcia, I., Powell, B. & Wang, D. S. 2020. Ventilator Sharing During an Acute Shortage Caused by the COVID-19 Pandemic. *American Journal of Respiratory and Critical Care Medicine*.
- Branson, R. D., Blakeman, T. C., Robinson, B. R. & Johannigman, J. A. 2012. Use of a single ventilator to support 4 patients: laboratory evaluation of a limited concept. *Respiratory care*, 57, 399-403.
- Chase, J. G., Chiew, Y.-S., Lambermont, B., Morimont, P., Shaw, G. M. & Desai, T. 2020a. In-Parallel Ventilator Sharing during an Acute Shortage: Too Much Risk for a Wider Uptake. *American Journal of Respiratory and Critical Care Medicine*, 202, 1316-1317.

- Chase, J. G., Chiew, Y. S., Lambermont, B., Morimont, P., Shaw, G. M. & Desaive, T. 2020b. Safe doubling of ventilator capacity: a last resort proposal for last resorts. *Critical Care*, 24, 222.
- Chase, J. G., Preiser, J.-C., Dickson, J. L., Pironet, A., Chiew, Y. S., Pretty, C. G., Shaw, G. M., Benyo, B., Moeller, K., Safaei, S., Tawhai, M., Hunter, P. & Desaive, T. 2018. Next-generation, personalised, model-based critical care medicine: a state-of-the art review of in silico virtual patient models, methods, and cohorts, and how to validation them. *BioMedical Engineering OnLine*, 17, 24.
- Chatburn, R. L., Branson, R. D. & Hatipoğlu, U. 2020. Multiplex ventilation: A simulation-based study of ventilating 2 patients with a single ventilator. *Respir Care*, 65, 920-931.
- Chiew, Y. S., Chase, J. G., Shaw, G., Sundaresan, A. & Desaive, T. 2011. Model-based PEEP Optimisation in Mechanical Ventilation. *BioMedical Engineering OnLine*, 10, 111.
- Clarke, A., Stephens, A., Liao, S., Byrne, T. & Gregory, S. 2020. Coping with COVID-19: ventilator splitting with differential driving pressures using standard hospital equipment. *Anaesthesia*.
- de Jongh, F. H., de Vries, H. J., Warnaar, R. S., Oppersma, E., Verdaasdonk, R., Heunks, L. M. & Doorduyn, J. 2020. Ventilating two patients with one ventilator: technical setup and laboratory testing. *ERJ Open Research*, 6.
- Gattinoni, L., Caironi, P., Cressoni, M., Chiumello, D., Ranieri, V. M., Quintel, M., Russo, S., Patroniti, N., Cornejo, R. & Bugeo, G. 2006. Lung recruitment in patients with the acute respiratory distress syndrome. *New England Journal of Medicine*, 354, 1775-1786.
- Gattinoni, L., Collino, F., Maiolo, G., Rapetti, F., Romitti, F., Tonetti, T., Vasques, F. & Quintel, M. 2017. Positive end-expiratory pressure: how to set it at the individual level. *Annals of translational medicine*, 5.
- Han, J. S., Mashari, A., Singh, D., Dianti, J., Goligher, E., Long, M., Ng, W., Wasowicz, M., Preiss, D. & Vesely, A. 2020. Personalized Ventilation to Multiple Patients Using a Single Ventilator: Description and Proof of Concept. *Critical Care Explorations*, 2, e0118.
- Major, V. J., Chiew, Y. S., Shaw, G. M. & Chase, J. G. 2018. Biomedical engineer's guide to the clinical aspects of intensive care mechanical ventilation. *Biomedical engineering online*, 17, 169.
- Morton, S. E., Knopp, J. L., Chase, J. G., Docherty, P., Howe, S. L., Möller, K., Shaw, G. M. & Tawhai, M. 2019. Optimising mechanical ventilation through model-based methods and automation. *Annual Reviews in Control*.
- Neyman, G. & Irvin, C. B. 2006. A Single Ventilator for Multiple Simulated Patients to Meet Disaster Surge. *Society for Academic Emergency Medicine*, 13.
- Ng, Q. A., Chiew, Y. S., Wang, X., Tan, C. P., Nor, M. B. M., Damanhuri, N. S. & Chase, J. G. 2021. Network Data Acquisition and Monitoring System for Intensive Care Mechanical Ventilation Treatment. *IEEE Access*, 9, 91859-91873.
- Ng, Q. A., Loo, N. L., Chiew, Y. S., Tan, C. P., Ralib, A. M. & Mat Nor, M. B. 2020. Mechanical Ventilation Monitoring: Development of a Network Data Acquisition System. *IFAC-PapersOnLine*, 53, 15916-15921.
- O'Driscoll, B., Howard, L., Earis, J. & Mak, V. 2017. British Thoracic Society Guideline for oxygen use in adults in healthcare and emergency settings. *BMJ open respiratory research*, 4, e000170.
- Paladino, L., Silverberg, M., Charchafli, J. G., Eason, J. K., Wright, B. J., Palamidessi, N., Arquilla, B., Sinert, R. & Manoach, S. 2008. Increasing ventilator surge capacity in disasters: ventilation of four adult-human-sized sheep on a single ventilator with a modified circuit. *Resuscitation*, 77, 121-126.
- Penarredonda, J. L. 2020. Covid-19: the race to build coronavirus ventilators. 2020.
- Poor, H. 2018. *Basics of Mechanical Ventilation*, Springer.
- Rees, S. E. 2011. The Intelligent Ventilator (INVENT) project: The role of mathematical models in translating physiological knowledge into clinical practice. *Computer Methods and Programs in Biomedicine*, 104, Supplement 1, S1-S29.
- SCCM, AARC, ASA, ASPF, AACN & CHEST 2020. Consensus Statement on Multiple Patients Per Ventilator. *SCCM Website* (<https://www.sccm.org/Disaster/Joint-Statement-on-Multiple-Patients-Per-Ventilato>).
- Smith, R. & Brown, J. 2009. Simultaneous ventilation of two healthy subjects with a single ventilator. *Resuscitation*, 80, 1087.
- Srinivasan, S., Ramadi, K., Vicario, F., Gwynne, D., Hayward, A., Langer, R., Frassica, J., Baron, R. & Traverso, G. 2020. Individualized System for Augmenting Ventilator Efficacy (iSAVE): A Rapidly deployable system to expand ventilator capacity. *BioRxiv*.
- Szlavec, A., Chiew, Y., Redmond, D., Beatson, A., Glassenbury, D., Corbett, S., Major, V., Pretty, C., Shaw, G., Benyo, B., Desaive, T. & Chase, J. 2014. The Clinical Utilisation of Respiratory Elastance Software (CURE Soft): a bedside software for real-time respiratory mechanics monitoring and mechanical ventilation management. *BioMedical Engineering OnLine*, 13, 140.
- The Acute Respiratory Distress Syndrome Network 2000. Ventilation with Lower Tidal Volumes as Compared with Traditional Tidal Volumes for Acute Lung Injury and the Acute Respiratory Distress Syndrome. *N Engl J Med*, 342, 1301-1308.
- Truog, R. D., Mitchell, C. & Daley, G. Q. 2020. The toughest triage—allocating ventilators in a pandemic. *New England Journal of Medicine*, 382, 1973-1975.
- van Drunen, E., Chiew, Y. S., Chase, J., Shaw, G., Lambermont, B., Janssen, N., Damanhuri, N. & Desaive, T. 2013. Expiratory model-based method to monitor ARDS disease state. *BioMedical Engineering OnLine*, 12, 57.
- van Drunen, E. J., Chiew, Y. S., Pretty, C., Shaw, G. M., Lambermont, B., Janssen, N., Chase, J. G. & Desaive, T. 2014. Visualisation of time-varying respiratory system elastance in experimental ARDS animal models. *BMC Pulm Med*, 14, 33.