



**Marc Philippart de Foy, Ezgi Uslu, and Andreas Pfennig**  
 University of Liège, Department of Chemical Engineering – PEPs, Belgium  
<https://www.chemeng.uliege.be> – marc.philippartdefoy@uliege.be

## Motivation

challenge: ores, waste, fermentation broth: complex mixtures of valuable components  
 conventional solution: complex multi-step hydrometallurgical separations  
 efficient recycling of critical metals (Co, Li, REEs) and other components: circular economy and urban mining

## Goals

simple, high purity and high concentration separation process

## Theoretical basis

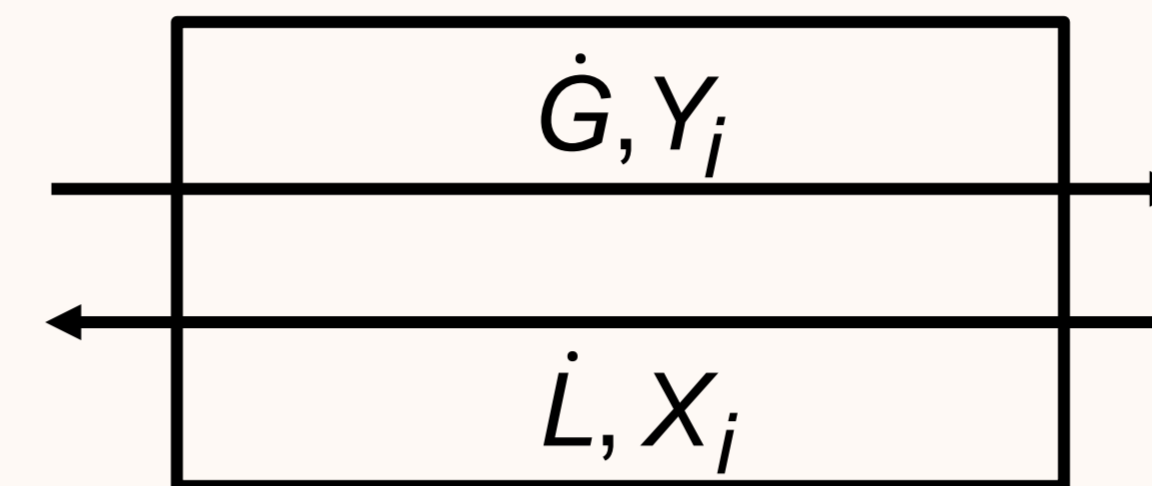

net flow rate:

$$\dot{G}Y_i - \dot{L}X_i = \dot{L}X_i \left( \frac{\dot{G}Y_i}{\dot{L}X_i} - 1 \right) = \dot{L}X_i \left( \frac{\dot{G}K_i}{\dot{L}} - 1 \right) = \dot{L}X_i (\lambda_i - 1)$$

## Process Idea: SisClever Process

Simultaneous Separation of multi-Component systems to high LEVEL of Recovery

- accumulation zones,  $\lambda_i = 1$ , for each component individually along the process
- example for reactive extraction: impose corresponding pH-profile

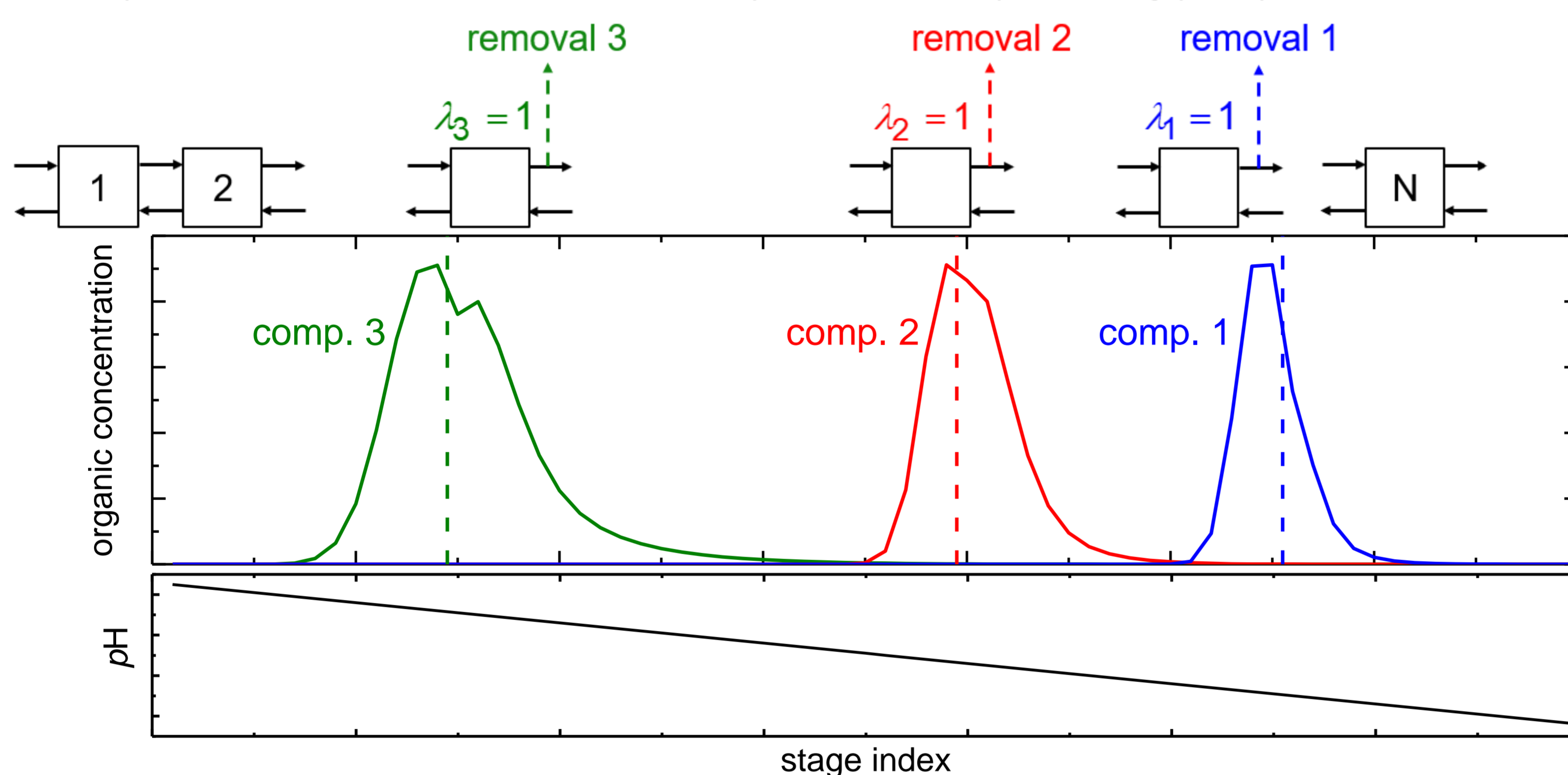

Figure 1. schematic representation of the SisClever process idea with three transfer components, in the case of reactive extraction of metal cations where a pH-profile is imposed

## Experimental validation

started from simulated steady state c-profiles  
 pseudo-continuous operation in beakers with syringes  
 constant pH-profile with HCl and NaOH injections  
 → steady-state c-profiles after 5 residence times

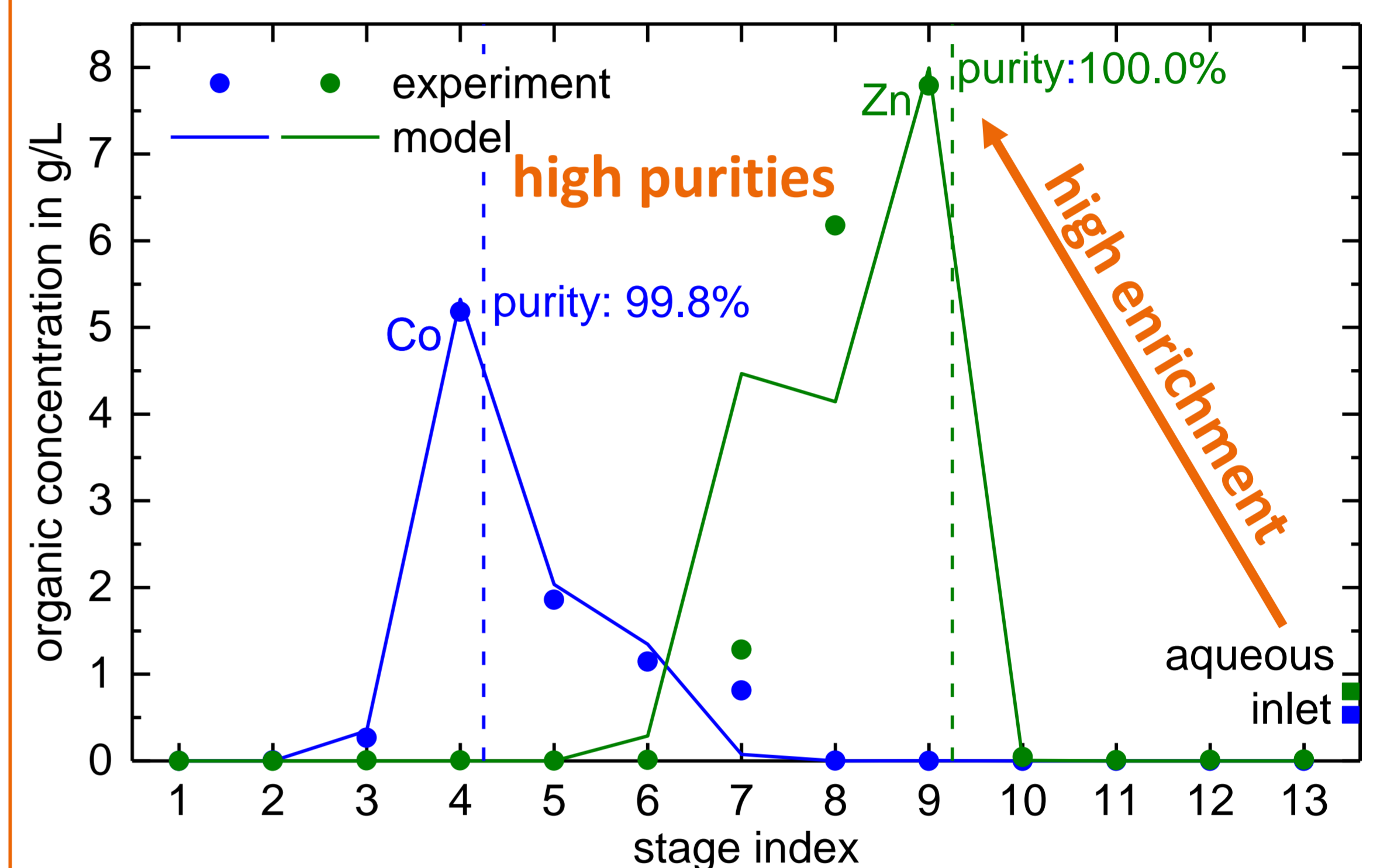

Figure 2. experimental result compared to simulated steady state

## Application to REE recycling

- comparison to a conventional optimized process from literature [1]
  - equilibrium based on experimental data from [1]
  - 7 metals separated into 5 product streams
  - optimized pH-profile to minimize the number of theoretical stages:
- |            |   |
|------------|---|
| [1]:       | 104 stages                                |
| SisClever: | 29 stages (24: separation + 5: stripping) |
- at least same purities
  - higher enrichment for several metals with SisClever

[1] Srivastava VK. Modeling of Rare Earth Solvent Extraction Process Modeling of Rare Earth Solvent Extraction Process for Flowsheet Design and Optimization for Flowsheet Design and Optimization, Ph.D. Dissertation. University of Kentucky; 2021. doi:10.13023/etd.2021.220

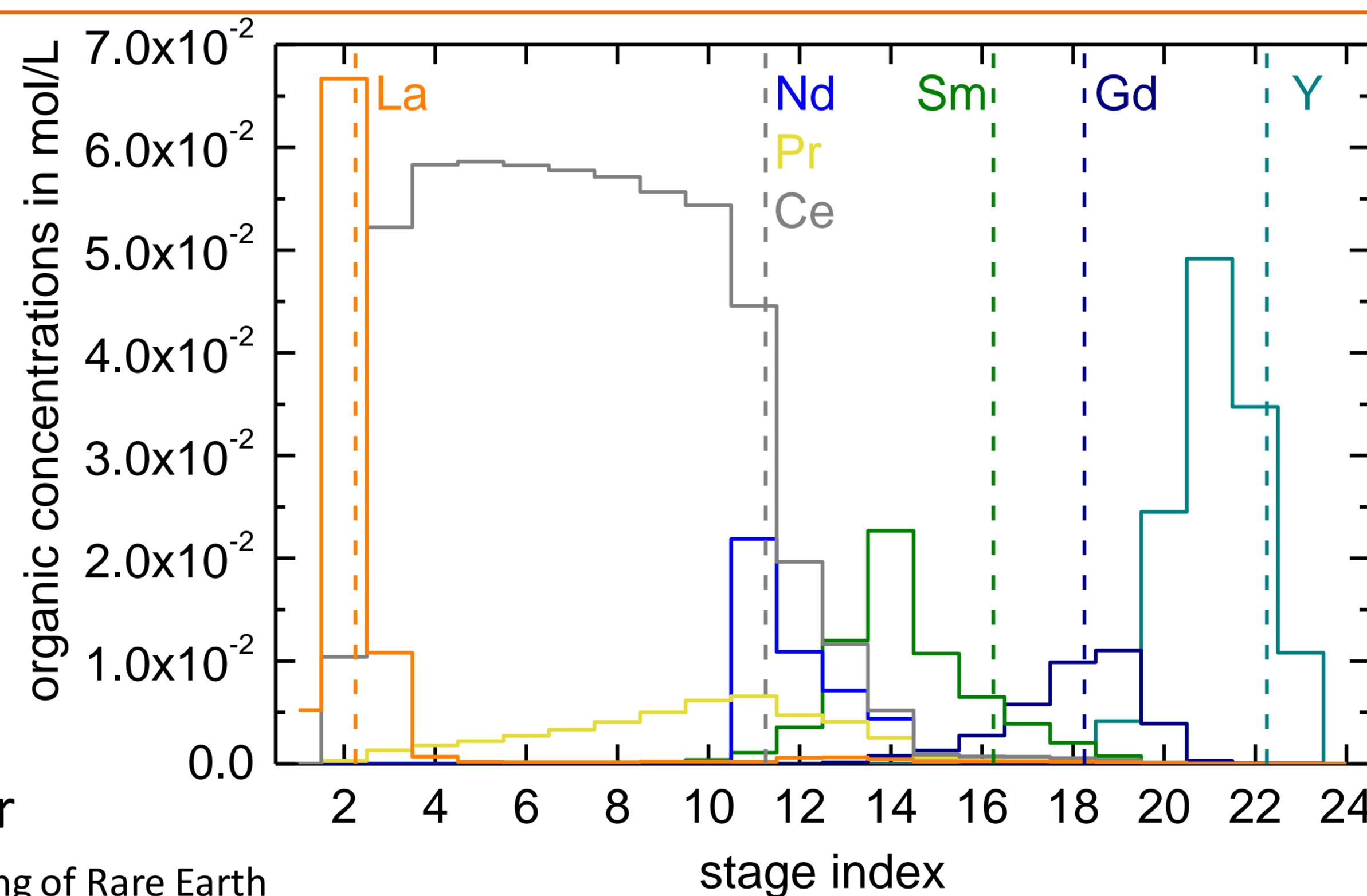

Figure 3. steady-state organic concentration profiles along the SisClever process

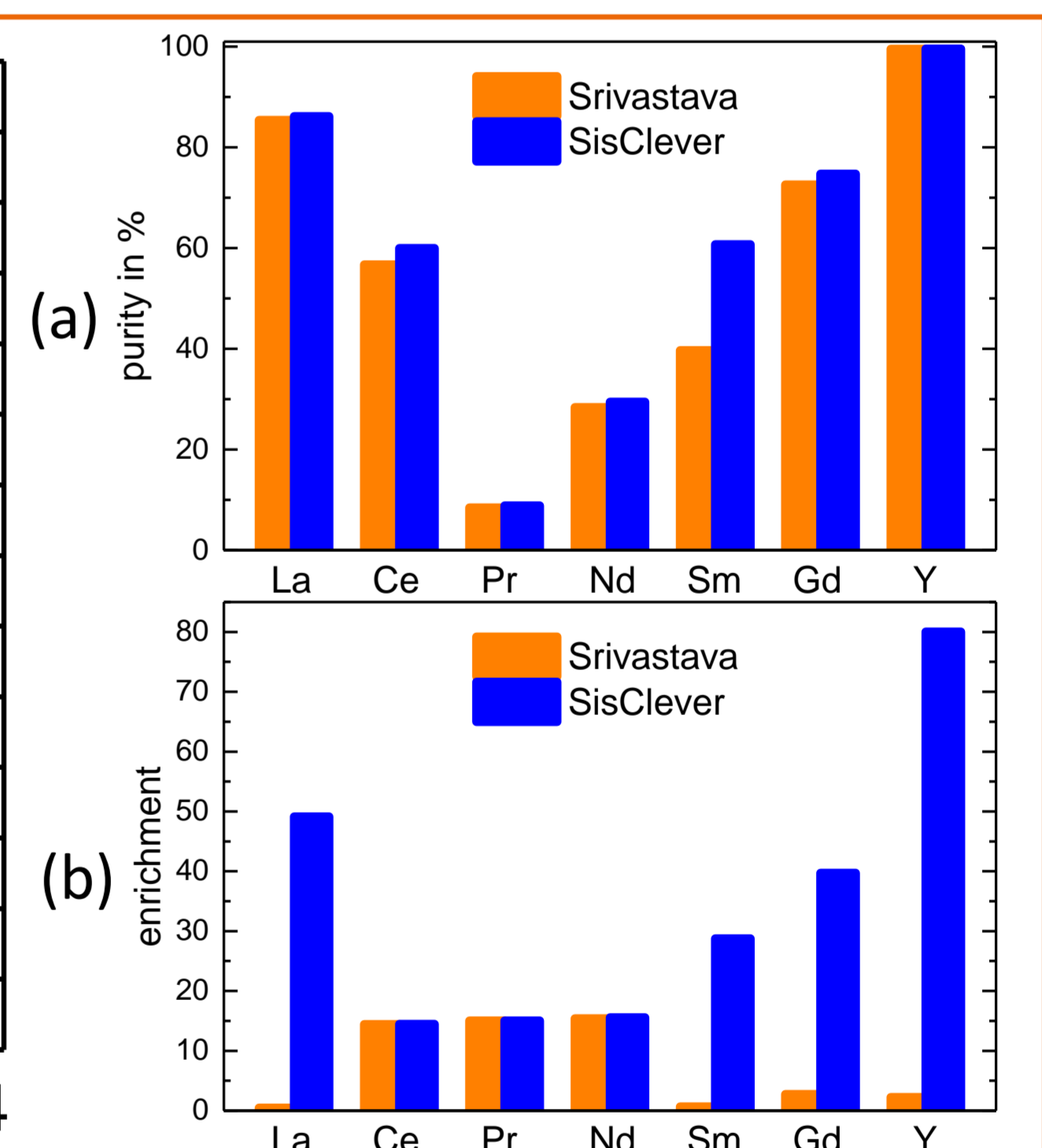

Figure 4. comparison between [1] and the SisClever process for (a) product purity and (b) enrichment

## Advantages

- high purity by adjusting theoretical stages
- high enrichment via small product removal flowrates
- recovery of minor components from disparate feed
- flexible product concentration by controlling removal streams
- main flowrate ratio around 1: easy operation and control

## Limitations

- single extractant: challenge for future extractant development
- components with too similar equilibrium: single product

## Next step

- 18 stages continuous MSU 0.5 mixer-settlers battery with pH and flow control
- process monitoring and control via LabVIEW
- test for up to four-metal separation

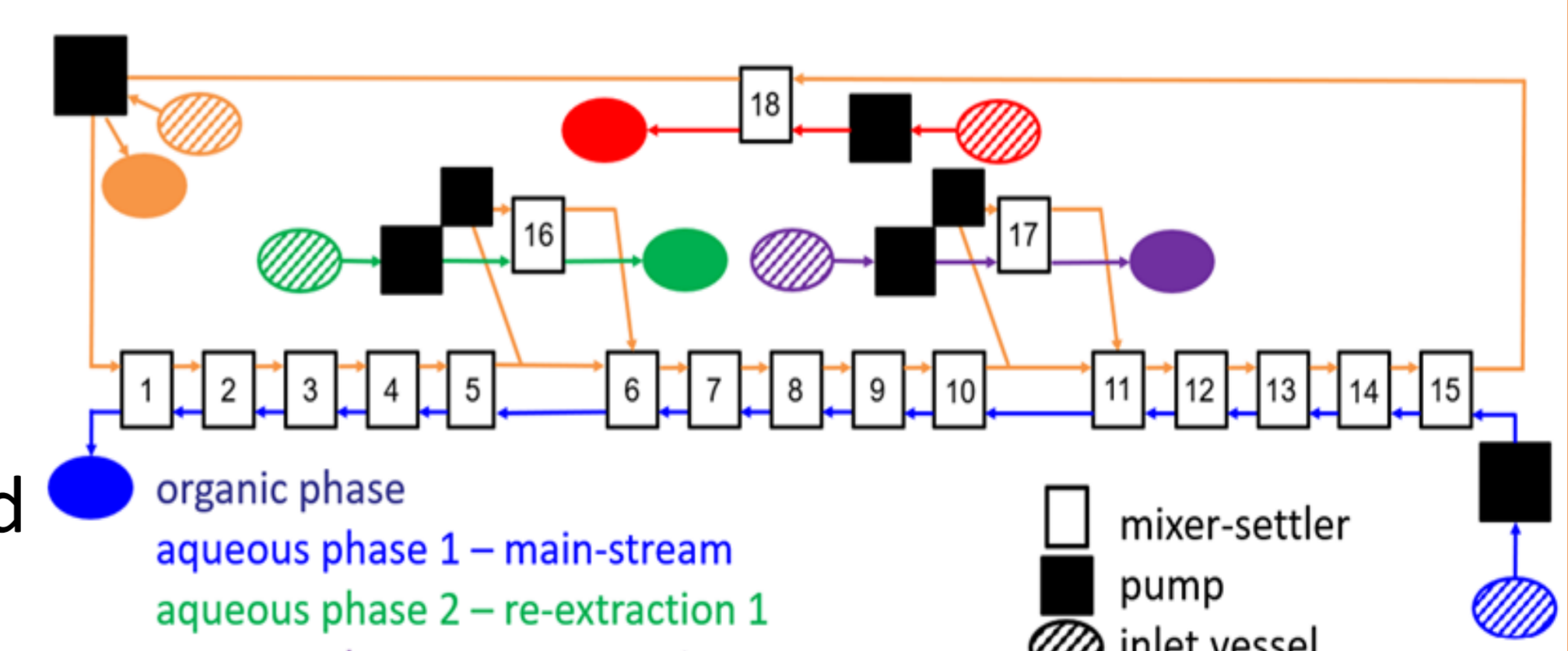

Figure 5. 18 stages mixer-settler configuration

## Take-home messages

- efficient hydrometallurgy and recycling: high purity and concentration with minimal processing steps
- easy extraction and purification of valuable metals from primary and secondary resources: fosters urban mining and circular economy
- potential applications: cation-exchange extraction and metal separation, anion-exchange separation like organic or amino acids, others