



# Soil conservation projects and their consequences: the behavior analysis of Iranian farmers

Ahmad Yaghoubi Farani<sup>1</sup> · Saeid Hedayati Nia<sup>1</sup> · Karwan Shanazi<sup>1</sup> · Pouria Ataie<sup>2</sup> · Karim Naderi Mahdei<sup>1</sup> · Hossein Azadi<sup>3</sup>

Received: 17 April 2023 / Accepted: 4 February 2024  
© The Author(s), under exclusive licence to Springer Nature B.V. 2024

## Abstract

This study aims to evaluate the consequences of protective tillage projects and investigate farmers' behavior during their implementation, contributing to the field of sustainable agriculture. The study focused on farmers participating in a soil conservation project in Kermanshah County, Iran (N=70). Employing a quantitative approach, a validated questionnaire serves as the research instrument, ensuring the reliability of data collection. The study identified the social, environmental, and economic factors as the most significant consequences of the protective tillage project according to farmers' rankings. The study uncovers that implementing the protective tillage project not only leads to desirable outcomes such as income generation, employment opportunities, and improved social welfare but also enhances community participation and communication within the region. This novel finding highlights the social benefits associated with agricultural innovations and emphasizes the importance of fostering local engagement. Furthermore, the study sheds light on the factors influencing farmers' behavioral intentions. It identifies mental norms, attitudes, and perceived behavioral control as significant determinants of farmers' willingness to adopt protective tillage practices. This insight provides valuable guidance for designing effective intervention strategies and promoting behavioral changes among farmers, ultimately fostering the adoption of sustainable agricultural practices. In conclusion, this research contributes to the literature on sustainable agriculture by evaluating the consequences of protective tillage projects, uncovering the social benefits they bring, and exploring the underlying factors that drive farmers' behavioral intentions. By aligning protective tillage systems with farmers' behavioral processes, long-term sustainability in agriculture can be ensured. The study emphasizes the necessity of collaborative efforts between farmers and extension agencies in delivering soil conservation projects effectively. Ultimately, this study demonstrates the applicability of behavioral theories in driving agricultural innovations, paving the way for future research and policy development in the field of sustainable agriculture.

**Keywords** Conservation tillage · Consequences assessment · Sustainable agriculture · Farmers · Behavior

## 1 Introduction

Agriculture is one of the oldest forms of economic and productive activities in societies (He, 2023; Kicińska & Wikar, 2021). It plays major roles such as providing food, facilitating the development of other sectors through the creation of economic surplus, providing capital for economic growth, providing energy, saving the workforce, and helping the market of industrial goods (Abbasi et al., 2022; Brown et al., 2018). The limited outlook of most projects regarding development has harmed and destabilized the agriculture section more than any other section (Doran et al., 2020). The severe erosion of soil, desertification, turning lands into salt marshes, the overuse of water resources, and the acute shrinkage of underground water reservoirs are some instances of such instability (Bouwman et al., 2021; Mamani et al., 2022; Rahayu et al., 2023; Tama et al., 2020; Zhang et al., 2022). Over the past decade, the irregular exploitation of environmental potentials according to improper managerial models and the wastage of important agricultural resources like water and soil have resulted in the reduction of the environmental capacity and consequently severe economic, social, and environmental crises (Mao et al., 2018; Taqi Ghulam & Abushammala, 2023; Werner et al., 2017; Zhou et al., 2020).

Limited water resources, erosion, reduced fertility of soils, climate change, and increased costs of agricultural inputs and food are the main challenges to achieving food security in many countries (Latifi et al., 2017a; Ouyang et al., 2022; Panyasing et al., 2022). Demand for food increases as the population of the world grows, but food security will suffer serious crises due to factors such as increasing the erosion of the soil, reduced fertility of soil, and the wastage and destruction of the physical properties of agricultural lands (Brown et al., 2017; Nawaz et al., 2021; Nguyen-Chi et al., 2022). Therefore, reduced fertility of soil due to the shrinkage of its organic materials and nutrients, which is caused by erosion, is among the major concerns in agriculture that threaten farmers' livelihoods (Van Hoa et al., 2022; Yang & Sang, 2020).

Based on the above arguments, though the soil is an important agricultural resource, this vulnerable resource faces destruction because of improper management, lack of concern, and irregular exploitation. FAO and ITPS (2015) reported tillage-induced soil erosion of 5 Gt (gigaton) yearly. Soil erosion is not only a significant environmental crisis in Iran but also has been shown to have a broad-scale impact on the country's economy. With each ton of soil estimated to be worth 28 USD, it can be asserted that the annual cost of soil erosion in Iran is 56 billion USD, bringing a lot of cost to the government of Iran. Statistics reveal that 94% of lands in Iran are on the verge of destruction, and Iran is ranked second in the world in terms of soil erosion (Seifi et al., 2018). Figure 1 illustrates the soil erodibility in Iran. Vast parts of Iran have dry and semi-dry climates because of being located on the desert belt of the world (Rezaei Moghaddam et al., 2017). Mohammadi et al. (2018) pointed out that the highest rate of soil erosion in Iran is related to the Western and Northwestern provinces. No region in Iran, including the central, eastern, and southern regions, is secured from the phenomenon of erosion (Motalebani et al., 2020).

Agricultural land is one of the most important elements in producing agricultural crops, and its quality is important for farming performance and sustainable development (Abbasi et al., 2023; Abidin et al., 2022; Parwada & Marufu, 2023). That's why soil degradation is, therefore, the most serious threat to agricultural production around the world. Soil erosion and soil moisture loss are the major problems that should be seriously considered in the case of degraded soils, particularly in semi-arid areas (Mgolozeli et al., 2020; Serbaji et al., 2023).

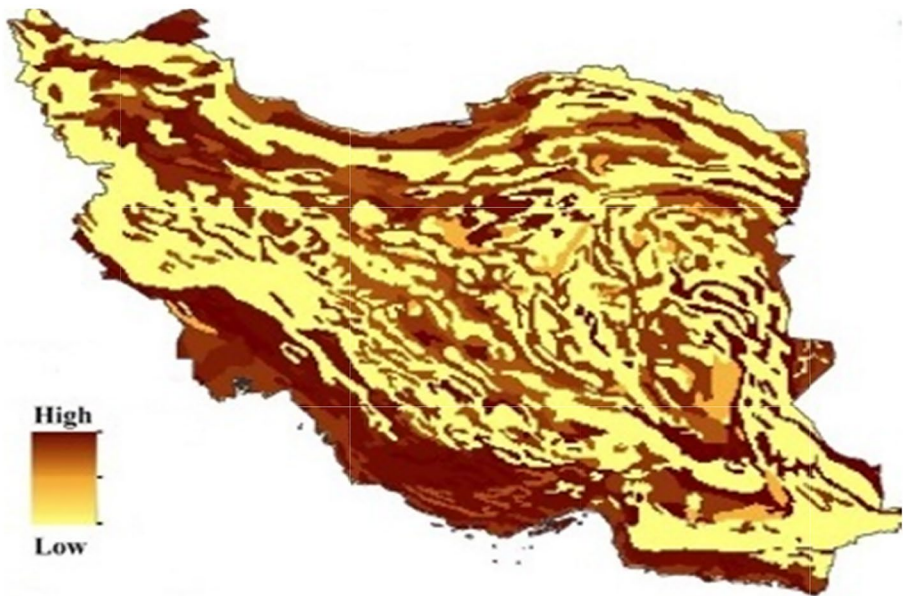

**Fig. 1** The soil erodibility in Iran

There are quite diverse approaches to deal with the destruction of soil resources and challenges in the agricultural sector that have been presented in a package called “conservation agriculture” (Olawuyi & Mushunje, 2020; Satria et al., 2022), and for this reason, conservation agriculture has become a necessity for many countries faced with challenges like limited arable lands, soil destruction and erosion, shortage of water and its low efficiency, and the poor performance due to the gradual loss of the quality of arable lands (Bouwman et al., 2021; Brown et al., 2018; Fuentes-Llanillo et al., 2021; Hekmatnia et al., 2023; Holden et al., 2018; Wang & Wang, 2022). Thus, applying conservation agricultural and tillage systems is essential for overcoming or alleviating the above problems and benefiting from the advantages of modern agriculture (Brown et al., 2020; Fuentes-Llanillo et al., 2021; Holden et al., 2018; Huang et al., 2018) as a way of sustaining the production processes and the continuity of growing crops (Latifi et al., 2017b).

Even though soil conservation is a serious issue in agriculture (Akinyemi et al., 2021; Qin et al., 2020; Reimer et al., 2023) and food security (Mango et al., 2017), no considerable attempt has been made to deal with it in Iran. A fundamental reason for this ignorance is the lack or shortage of financial assistance and investment by the government and other agencies (Kifle et al., 2016; Momeni et al., 2012). The lack of public awareness of the economic, social, and environmental benefits of conserving soil in Iran is another factor in this regard (Abbasi & Erdebilli, 2023; Abbasi et al., 2021). Nevertheless, clause 41 in the 6th Development Plan of Iran regards the development of conservation agriculture as one of the major steps towards the attainment of the goals specified by the “Resistive Economy” to achieve food security and self-sufficiency in the production of primary products and enhance the efficiency of water and soil (Latifi et al., 2018). Therefore, performing land management as a way to move towards sustainable agriculture, redistribution of resources towards the present generation, maintaining the quality and quantity of soil as the most important ground for the production of agricultural goods, and prevention of migration

from villages are necessary for the development of rural areas (Ghanbari et al., 2018; Toulabi Nejad et al., 2017). This is because the major part of soil destruction is related to the inconvenient management of farm soil by farmers (Zhou et al., 2020), which originates from their managerial knowledge and behavior in conserving the soil. Thus, finding the factors influencing the conservation of soil is essential and vital to making constant use of soil resources, and the success of soil conservation programs and using soil efficiently require the understanding of the multiple aspects of human behavior and the factors that influence it.

A review of recent studies (Ataei et al., 2019; Qin et al., 2020; Ghosh et al., 2015) shows that the conservation agriculture project has long been successfully used in many countries. However, most studies have investigated the conservation agriculture project based on technical and experimental aspects and have not identified farmers' behavior and its consequences such as the effect of conservation agriculture on reducing water erosion (Blanco-Sepúlveda et al., 2021), grain production and food security (Anghinoni et al., 2021), weed community diversity (Derrouch et al., 2021), crop performance, profitability and soil health (Jat et al., 2021), physico-chemical soil attributes (Mutuku et al., 2021), the adaptive capacity of cropping systems (Komarek et al., 2021), climate adaptation (Tambet & Stopnitzky, 2021), etc. However, so far, too little attention has been given to investigating the consequences of conservation agriculture based on farmers' behavior. In other words, very few empirical studies (such as Ashoori et al., 2017; Ataei et al., 2019, 2020) have investigated behavioral, psychological, and socio-cultural aspects of conservation agriculture in Iran, and most studies have considered other aspects. Sustainable agriculture plays a critical role in addressing environmental challenges and ensuring long-term food security. Within the realm of sustainable agriculture, protective tillage projects have gained attention as effective interventions for soil conservation. These projects aim to mitigate soil erosion, enhance soil quality, and promote sustainable farming practices. While previous studies have explored the impacts of various agricultural interventions, there is a significant research gap when it comes to the consequences of protective tillage projects and understanding farmers' behavior during their implementation. This study aims to fill a significant research gap in the field of sustainable agriculture by evaluating the consequences of protective tillage projects and investigating farmers' behavior during their implementation. While previous studies have explored the impacts of agricultural interventions, there is limited research specifically focusing on the outcomes of protective tillage projects and farmers' behavioral intentions in adopting such practices. This study fills this gap by providing a comprehensive assessment of the consequences and factors influencing farmers' behavior in the context of a soil conservation project in Kermanshah County, Iran. Furthermore, this study offers several noteworthy contributions to the existing literature. Firstly, it identifies the social, environmental, and economic factors as the most significant consequences of the protective tillage project based on farmers' rankings. This detailed analysis provides valuable insights into the multifaceted impacts of protective tillage projects, contributing to a deeper understanding of their potential benefits and implications for sustainable agriculture. Secondly, the study reveals that implementing the protective tillage project not only leads to desirable outcomes such as income generation, employment opportunities, and improved social welfare but also fosters community participation and communication within the region. This novel finding highlights the social benefits associated with agricultural innovations and underscores the importance of local engagement. Thirdly, the study investigates the factors influencing farmers' behavioral intentions. It finds that mental norms, attitudes, and perceived behavioral control significantly impact farmers' willingness to adopt protective tillage practices. This insight provides valuable

guidance for designing effective intervention strategies and promoting behavioral changes among farmers, ultimately facilitating the adoption of sustainable agricultural practices. In conclusion, this study bridges a crucial research gap in the field of sustainable agriculture by evaluating the consequences of protective tillage projects and exploring the underlying factors driving farmers' behavioral intentions. By aligning protective tillage systems with farmers' behavioral processes, long-term sustainability in agriculture can be ensured. The study emphasizes the necessity of collaborative efforts between farmers and extension agencies in delivering soil conservation projects effectively. Furthermore, the application of behavioral theories in driving agricultural innovations is demonstrated, opening avenues for future research and policy development in the field of sustainable agriculture.

The objectives of the current study include:

1. Investigating farmers' behavior towards engaging in conservation agriculture projects;
2. Understanding the socio-psychological components that influence farmers' behavior towards engaging in conservation agriculture projects;
3. Investigating the effectiveness of using the TPB model to explain farmers' behavior towards engaging in conservation agriculture projects; and
4. Investigating the consequences of adopting conservation agriculture projects.

## 2 Theoretical background

Within the realm of sustainable agriculture, protective tillage projects have gained attention as effective interventions for soil conservation (Abbasi et al., 2023). These projects aim to mitigate soil erosion, enhance soil quality, and promote sustainable farming practices (He, 2023). While previous studies have explored the impacts of various agricultural interventions, there is a significant research gap when it comes to the consequences of protective tillage projects and understanding farmers' behavior during their implementation. However, at the regional level, the Kermanshah Soil Conservation Project in Iran serves as an important example. This project focuses on implementing protective tillage practices to combat soil erosion and degradation in Kermanshah County. By engaging local farmers and providing them with resources, technical support, and training, the project aims to improve soil health and promote sustainable agricultural practices. Evaluating the outcomes of this regional project will provide valuable insights into the effectiveness of protective tillage practices in the local context. Furthermore, on a national scale, the Conservation Effects Assessment Project (CEAP) in the United States is a prominent initiative. CEAP assesses the impacts of various conservation practices, including protective tillage, on soil health, water quality, and biodiversity across different regions of the country. By collecting comprehensive data and conducting rigorous analyses, CEAP provides evidence-based information to guide policy decisions and resource allocation for soil conservation at the national level. Examining the findings and methodologies of CEAP can contribute to a broader understanding of the consequences of protective tillage projects in different geographical contexts. In addition, at the global level, the Food and Agriculture Organization of the United Nations (FAO) has been actively promoting soil conservation projects through initiatives such as the Global Soil Partnership. This international collaboration aims to address soil-related challenges and support sustainable land management practices worldwide. The FAO's work includes advocating for protective tillage practices, disseminating knowledge

and best practices, and facilitating capacity-building efforts among member countries. Understanding the global context and initiatives led by organizations like the FAO can provide valuable insights into the broader implications and benefits of protective tillage projects on a global scale (Abbasi et al., 2022, 2023).

## 2.1 Conservation agriculture

Conservation agriculture was introduced as a system to protect the soil in the U.S. during the 1930s and has been expanded over the past years. Conservation agriculture is “a concept of crop production that enables a high and sustained level of production and an acceptable profit, while at the same time conserving resources and the environment” (FAO, 2013). Currently, only 180 million hectares of land are subject to conservation agriculture, where the total area under cultivation worldwide is 1407 million hectares (Chatterjee & Acharya, 2021). The general goal of conservation agriculture is the proper use of agricultural resources through managing water and soil resources and biological activities (Chatterjee & Acharya, 2021). In conservation agriculture, herbicides and insecticides are applied when necessary, and the general emphasis is on using mechanical and natural methods (Zhou et al., 2020). Thus, operations such as the combined management of blights, weeds, and soil fertility are emphasized. Some advantages of this kind of agriculture are the sustainable fertility of soil, maintaining the moisture of the soil, reducing the surface runoffs, making efficient use of inputs, reducing the overall costs of the agricultural process, and finally the significant increase in the quantity of products (Fuentes-Llanillo et al., 2021).

Further advantages of conservation agriculture include protecting water and soil, protecting the landscape, reducing the occurrence of floods, reducing the pollution of waterways by sediments, and alleviating drought in the future (Huang et al., 2018; Mugandani & Mafongoya, 2019; Ndah et al., 2020; Olawuyi & Mushunje, 2020). Soil conservation refers to a set of strategies applied to prevent the erosion of soil (Stašek et al., 2023). The correct and constant operation of soil conservation includes crop rotation, covering plants, and shelterbelts that enable the surface soils to maintain their moisture and integrity through the reduction of eroding forces and the chemical changes of the nutrients (Karani et al., 2014; Yang & Sang, 2020).

Using the reduced tillage system as a method of soil conservation across the year (Razafimahatratra et al., 2021; Sahu et al., 2020; Sousa et al., 2020) has been recommended. This method reduces soil erosion by limiting evaporation with plant residues. It also increases soil permeability and moisture (Mousavi et al., 2012). The advantages of a conservation agriculture system include the low need for the workforce and saving time, fuel, and machinery. It also improves the cultivability of soil, protects the organic materials of soil, saves soil moisture, and reduces the degradation of soil (Motalebani et al., 2020). Three major principles of a conservation tillage system include the minimum destruction of soil (meaning the minimum tillage and the direct sowing of seeds), preserving the remains of products or other coverings on the surface of the soil – including the green manure, and variation through performing crop rotation or intercropping systems (Lalani et al., 2016; Richards et al., 2014).

## 2.2 Iran's ICARDA food security plan

Iran's ICARDA<sup>1</sup> food security plan has a 5-year perspective for a 25% increase in the production of various dry-farming crops including wheat, barley, and chickpea, and conservation tillage is one of the most prominent goals in this plan ([www.icarda.org](http://www.icarda.org)). Conservation agriculture is one of the ways to increase the production of these products and its objective is to reduce rural poverty, increase food security, and manage natural resources (Tama et al., 2020). In order to increase the production performance and soil conservation in dry-farming lands, the Iranian Ministry of Agriculture signed a cooperation agreement with ICARDA, in some provinces with dryland farms and cold climates (such as Kermanshah, Kordestan, East Azerbaijan, and Lorestan). The other target of this cooperation was to increase the use of certified and resistant seeds applying modern technologies and farm management techniques by farmers.

To attain the specified objectives, the focus of this cooperation was on several strategic priorities like maintaining and retaining biological diversity in dry areas, convenient and flexible cultivation, the integrated expansion of the agricultural system to improve people's livelihood, optimizing socioeconomic and environmental benefits, sustainable management of water and land, increasing gender equality, and strengthening socioeconomic capacity (ICARDA, 2016). In this cooperation agreement, 905,000 (ha) out of the 2 million ha of dry-farming lands in the selected provinces were assigned for raising wheat, barley, and chickpea. ICARDA defines its goal as the attainment of flexible and lucrative livelihoods in the dry areas of developing countries such as Iran from fair, rightful, stable, and innovative channels. In addition, it pursues innovative scientific solutions to improve the livelihood and flexibility of poor and vulnerable people in non-tropical dry areas to alleviate poverty, increase food, and enhance water security through the sustainable management of natural resources faced with climate changes (ICARDA, 2017).

Some other major advantages of this plan include reducing the need for tractors and other machinery on farms, saving the operation time on farms, reducing the depreciation rate of machinery and the consumed energy, reducing environmental pollution by stopping the burning of straw chaff, etc. (Tama et al., 2020).

## 2.3 Literature review

Some African countries (like Zambia, Tanzania, and Kenya) and some Asian countries (like Pakistan, China, Kazakhstan, Syria, and India) have applied various types of conservation agriculture systems among their farmers (Friedrich et al., 2009) since the increased cost of fuel required for the conventional tillage operations has forced states and farmers to change methods of tillage and find more economical and environmental tillage methods (Shamabadi, 2015). The studies conducted by Yang and Sang (2020) indicate that conservation agriculture has added value, though it will appear in the long run. Santos Telles et al. (2018) indicated that agricultural lands cultivated according to the no-tillage system are more valuable compared to the other lands, and this can motivate governments to increase and enhance conservation agriculture among farmers. In addition, Pradhan et al. (2018) indicated that conservation agriculture and convenient tillage in India have brought about significant changes in economic livelihood, environmental stability, improved social

---

<sup>1</sup> International Center for Agricultural Research in the Dry Areas.

conditions, and food security. The findings of Holden et al. (2018) showed that low tillage and zero tillage systems slightly increase the performance of wheat seeds in comparison with conventional tillage. Furthermore, Abdollahpour and Karparvarfard (2017) measured the moisture of soil after 10 days. They concluded that the moisture supply in direct cultivation has increased by 1.87% compared to conventional methods (meaning that direct cultivation and no-tillage methods are more efficient in terms of preserving moisture). In addition, Vastola et al., (2017) concluded that conservation agriculture can be a convenient replacement for conventional agriculture. Furthermore, Fuentes-Llanillo et al. (2021) showed that conservation agriculture performs better than conventional tillage in terms of improving the quality of the soil. The soil in conservation agriculture systems is in a better position in terms of the activity of organisms and the improvement of biological properties. Furthermore, products grown in the no-tillage system have better performance and are more adapted to climate changes (e.g., drought and high temperatures). The findings of Mugandani and Mafongoya (2019) showed that the areas where conservation agriculture had been used developed more rapidly. This was attributed to the increased environmental awareness like soil conservation and production management.

Based on the above discussion, changing farmers' behavior from the conventional methods towards conservation agriculture will bring about positive impacts on conserving soil resources and the economic, social, and environmental issues. In this regard, understanding the fundamental determinants of behavior is considered a major objective in many theories proposed within the social sciences (Gao et al., 2017). Any person has to have beliefs about a particular issue to show a particular behavior or action. Such beliefs influence one's attitudes, then affect their intention and tendencies and result in a particular behavior. In the field of behavioral psychology, there are several major theories like the Theory of Reasoned Action (TRA), the Technology Acceptance Model (TAM), and the Theory of Planned Behavior (TPB). In this regard, the TPB is a comprehensive model, which can efficiently account for humans' behavior in protecting natural resources. The main mechanism of the TRA (Ajzen, 1991) is based on the assumption that humans' behavior is affected by their tendencies, and the most important factors determining behavioral tendencies include perceived behavioral control, attitudes towards a particular behavior, mental norms, and behavioral intentions.

The findings by Sahraei et al. (2018) revealed that the constructs of attitude, perceived behavioral control, and mental norms had a significant impact on wheat producers' behavior. In addition, the study by Motalebani et al. (2020) using the TPB on the acceptance of conservation agriculture showed that the majority of constructs have a significant impact on behavioral intention, and attitude is the strongest factor influencing the intention to accept conservation agriculture. In addition, the study by Rafiei et al. (2016), Lalani et al. (2016), and Wauters et al. (2010) showed similar results. The study by Shahriyari Garaei (2012) indicated that attitudes toward soil conservation and perceived behavioral control significantly influence the decision to demonstrate farmers' behavior in soil conservation. In addition, the study by Agharajabi (2018) showed that behavioral intention is an important predictor of soil conservation behavior, and the remaining constructs of the TPB have a significant impact on behavioral intention, as well. Literature review reveals that most studies contributed to various aspects of soil conservation such as challenges and policies, advantages and disadvantages, consequences and impacts, social interaction, sustainability dimensions, and adoption of soil conservation. Table 1 shows the classification of sources and the contribution of science development in soil conservation.

It can be argued in a general manner that the acceptance of the conservation agriculture behavior can bring about positive economic, social, and environmental consequences based

**Table 1** The classification of sources and the contribution of science development in soil conservation

Subject	Scholar	Subject	Scholar
1. Adoption of conservation agriculture	Rafiei (2016), Ashoori et al. (2017), Latifi et al. (2017b), Agharajabi (2018), Seifi et al. (2018), Holden et al. (2018), Mugandani and Mafongoya (2019), Olawuyi and Mushunje (2020), Abadi et al. (2020), Motalebani et al. (2020), Tama et al. (2020), Razafimahatratra et al. (2021), Bouwman et al. (2021)	2. Challenges and policies	Friedrich et al. (2009), Bhan and Behera (2014), Richards et al. (2014), Kassam et al. (2015), Latifi et al. (2017a), Brown et al. (2018), Latifi et al. (2018), Ataei et al. (2021), Reimer et al. (2023)
3. Advantages and disadvantages	Stevenson et al. (2014), Nurbekov et al. (2014), Lienhard et al. (2014), Albertengo et al. (2014), Lalani et al. (2016), Brown et al. (2017), Yang and Sang (2020), Fuentes-Llanillo et al. (2021)	4. Consequences and impacts	Ghosh et al. (2015), Shamabadi (2015), Mango et al. (2017), Pradhanet al. (2018), Huang et al. (2018), Qin et al. (2020), Mgozoli et al. (2020), Ndah et al. (2020), Sahu et al. (2020), Zhang et al. (2022), Stašek et al. (2023)
5. Social interaction	Kifle et al. (2016), Sahraei et al. (2018), Ataei et al. (2019), Brown et al. (2020), Sousa et al. (2020), Chatterjee and Acharya (2021)	6. Sustainability dimensions	Vastola et al. (2017), Ataei et al. (2020), Nawaz et al. (2021)

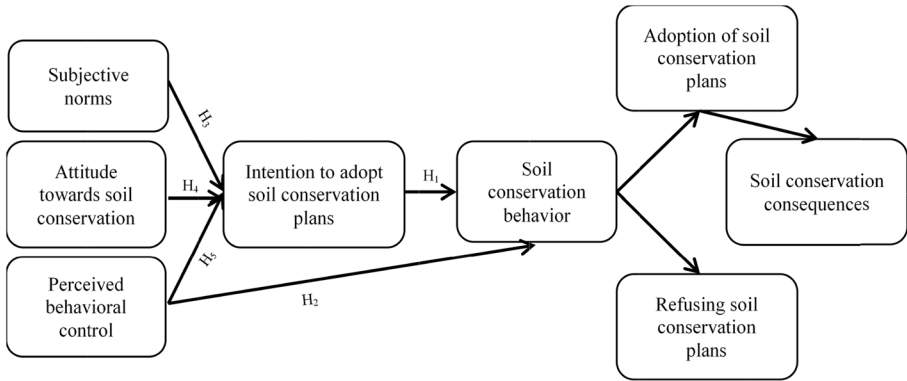

**Fig. 2** The theoretical framework of the study

on which people can make decisions whether to continue the scheme or leave it. It has been tried in the current study to investigate two major components including the factors influencing the acceptance of the plan and its consequences. This is because farmers will make decisions based on these consequences for the present and future. In this regard, factors that influence their decisions and the demonstration of their behavior can help the development of the expansion agriculture plan so that the infrastructures required to expand this plan in other regions of Iran can be established based on its consequences and the recognition of factors that influence it. Figure 2 illustrates the overall framework of the study based on which the plan will lead to consequences, and individuals can make decisions based on these consequences and transform these decisions into behavior. In fact, attitudes, mental norms, and perceived behavioral control will influence such influential decisions, and this mutual relationship will result in the acceptance and maintenance of the plan or its refusal.

Depending on the relations between the components of the theoretical framework (Fig. 2), the following assumptions may be suggested:

Hypothesis 1: Behavioral intention has a significant impact on farmers' soil conservation behavior.

Hypothesis 2: Perceived behavioral control has a significant impact on farmers' soil conservation behavior.

Hypothesis 3: Subjective norms have a significant impact on farmers' intention to adopt soil conservation plans.

Hypothesis 4: Attitude has a significant impact on farmers' intention to adopt soil conservation plans.

Hypothesis 5: Perceived behavioral control has a significant impact on farmers' intention to adopt soil conservation plans.

### 3 Methodology

#### 3.1 Study area

The study region comprises the lands of Baladarband plain (Sarab Niloufar) situated in the northwest of Kermanshah, in the west of Iran. The geographical position of this area

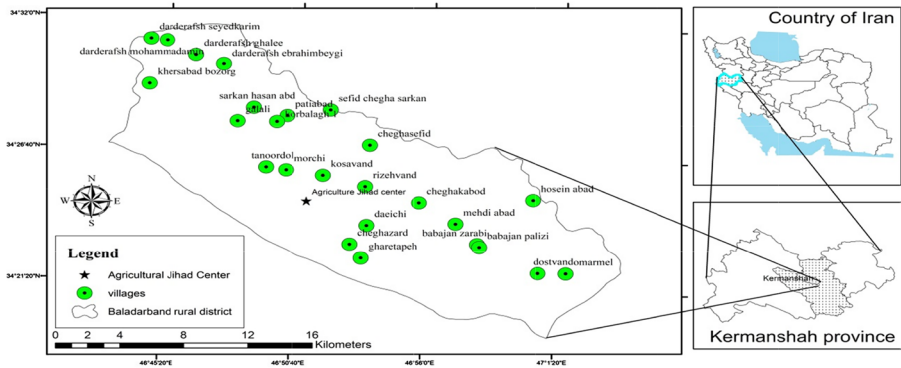

**Fig. 3** The domain of the study

is  $34^{\circ}24'$  north latitudes and  $48^{\circ}27'$  east longitudes that is located at an average altitude of 1320 m above sea level. The center of the rural district is located in the northwest of Kermanshah County at the foot of Komajar mountain. This rural district has 53 villages with an area of 29,300 hectares of agricultural land, of which 7,500 hectares are irrigated and 21,800 hectares are rainfed (Porhemmat et al., 2020). The average rainfall (2020) was 312.2 mm, which has decreased by about 41.8% compared to the previous crop year. Baladarband village district is one of the most important poles of producing agricultural crops in Kermanshah province. Wheat, barley, chickpeas, potatoes, rapeseed, and corn are the main products cultivated in this area. This area is also one of the most important tourist attractions of Kermanshah province in addition to the beautiful Sarab Niloufar Lake (Fig. 3).

### 3.2 Data collection and analysis

The current study is quantitative in nature, applied, and descriptive-correlational in nature. The research population consisted of all farmers in the Baladarband rural district of Kermanshah County, Iran, who participated in the conservation agriculture plan ( $N=70$ ). The sample was taken through 24 villages by the census technique. In the study area, the number of farmers who participated in the soil conservation project was small, and the authors had to choose them as the research samples. In addition, SEM was used to examine the structural model and measure the theoretical framework of the study. Due to the small-size samples, Smart PLS<sub>ver3</sub> was used. Because Smart PLS<sub>ver3</sub> is more suitable software for small-size samples (Hair et al., 2018). In general, it can be suggested that in future studies, if the number of research samples is small, path analysis or regression should be used instead of SEM so that the small number of research samples is not challenging. The data collection instrument was a structured questionnaire (designed in 9 parts related to the structures present in the behavioral model; the economic, social, and environmental impacts; and the demographic and personal features). The face validity of the questionnaire was confirmed by a panel of conservation agriculture and behavioral psychology experts. To assess the reliability of the study as shown in Table 2, a pilot study outside the studied sample was conducted and the Cronbach-Alfa coefficient was calculated. Furthermore, the Average Variance Extracted (AVE) and the Composite Reliability (CR) measures were measured to estimate the reliability of the constructs (Table 2).

**Table 2** The operational definition of the constructs applied in the current study. *Source:* Research findings (2019)

$\alpha$	AVE	CR	Conceptual and operational definitions	Index
–	0.58	0.797	Behavior refers to any kind of action that an individual performs. Behavior is also believed to be an individual's observable response and action in a particular situation and context, according to a particular objective, and during a particular time. In the current study, the behavior was evaluated using 8 questions related to (among others) returning the residues to the soil, raising cover plants, plowing correctly to decrease erosion, and using the Combined Tillage Machine in the form of yes/no questions	Soil conservation behavior
0.84	0.677	0.893	It reflects the strength or extent of one's will or motivation to demonstrate the target behavior. It was evaluated using 4 questions on the intention to apply soil conservation methods in agriculture, the intention to maintain the residues instead of burning them, the intention to encourage other farmers to use the combined tillage machine, and the intention to apply conservation methods to save time and reduce human presence using a 5-point scale (1: completely agree, 2: agree, 3: neuter, 4: disagree, and 5: completely disagree)	Intention of soil conservation
0.871	0.559	0.903	Attitude refers to an organized or particular set of beliefs that reflect people's inclination towards a subject or situation. In the current study, people's attitudes towards soil conservation were evaluated using 8 questions related to (among others) applying the combined tillage machine to reduce erosion, believing in leaving the plant residues on the soil, and performing no-tillage farming as a way to keep moisture in the soil in the form of a 5-point scale (1: completely agree, 2: agree, 3: neuter, 4: disagree, and 5: completely disagree)	Attitudes towards soil conservation and the conservation tillage
0.819	0.731	0.891	People's mental norms refer to how people who are important to us regard and evaluate a particular behavior. In the current study, the mental norm was evaluated using 3 questions related to the importance of the views put forwards by the experts in the Agricultural offices, by the acquaintances and relatives, and by the rural society and their advice regarding soil conservation in the form of a 5-point scale (1: completely agree, 2: agree, 3: neuter, 4: disagree, and 5: completely disagree)	The mental norms on soil conservation and conservation tillage
0.916	0.799	0.941	Perceived behavioral control defines the individual's perception of the internal and external limitations against the demonstration of a particular behavior and the perceived ease or difficulty of demonstrating such behavior. This construct was evaluated using 4 questions related to capability, endeavor, and responsibility in performing activities towards soil conservation, having the support and encouragement of experts and the local elders, believing in the skills and capabilities to encourage farmers towards the conservation of resources, and having sufficient and documented regulations, rites, and norms related to soil conservation in the form of a 5-point scale (1: completely agree, 2: agree, 3: neuter, 4: disagree, and 5: completely disagree)	Perceived behavioral control
0.755	0.655	0.858	19 questions on the impacts on income, savings, loans, ownership, and assets were evaluated using a 5-point scale (from +2: significantly increased to -2: significantly decreased)	Economic impacts

**Table 2** (continued)

$\alpha$	AVE	CR	Conceptual and operational definitions	Index
0.796	0.620	0.825	22 questions on the radius of support from people and institutions, justice, social welfare, participation, and educational and communicational channels using a 5-point scale (from +2: significantly increased to -2: significantly decreased)	Socioeconomic impacts
0.745	0.54	0.808	7 questions on the impacts of (among others) the use of chemical fertilizer, poisons, blights and diseases, the condition of the soil and leaving plant residues on it, using green fertilizer and returning it to the soil, and the combined management of blights using a 5-point scale (from +2: significantly increased to -2: significantly decreased)	Environmental impacts

They were performed using the Smart PLS<sub>ver3</sub>, and the criteria for their fitness were determined to be above 0.5 and 0.7, respectively.

Data analysis was performed using SPSS<sub>ver20</sub>, ArcMap<sub>ver10.2</sub>, and AMOS<sub>ver20</sub>. In addition, structural equation modeling (SEM) was applied to analyze the relationship between the study variables. The SEM can be considered a quantitative technique that helps researchers organize theoretical investigations and experimental data, within a multivariate framework (Weston & Gore, 2006). The path model is among the models, which can be applied in formulating and predicting various phenomena.

ArcMap<sub>ver10.2</sub> was applied to show the spatial stratification and distribution of conservation agriculture in terms of economic, social, and environmental dimensions in the villages taking part in the study. For this stratification, in terms of the level of distribution analysis and the influence coefficient, the differences between SD and Mean were investigated at three levels (A = low influence, B = average influence, C = high influence) (Eq. 1).

$$A < Mean - \frac{1}{2}SD \quad (1)$$

$$Mean - \frac{1}{2}SD < B < Mean + \frac{1}{2}SD$$

$$C > Mean + \frac{1}{2}SD$$

$$A < Mean - \frac{1}{2}SD$$

$$Mean - \frac{1}{2}SD < B < Mean + \frac{1}{2}SD$$

## 4 Results

### 4.1 Demographic characteristics

The descriptive data collected from the respondents and farmers taking part in the study indicate that 97.1% (68 respondents) were male, and 2.9% (2 respondents) were female. The average age of the studied people was 48.2 with an SD = 9.27. In addition, 71.4% (50 respondents) stated that they own the land, and only 28.6% (20 respondents) participated in the study on leased farms. On the other hand, the average farming experience of the respondents—based on their statements—was 22.3 years with SD = 6.27. Furthermore, the average land assigned to raising the three important crops related to the ICARDA plan in the investigated area was 5 (ha) for chickpea, 1.8 (ha) for barley, and around 1.6 (ha) for wheat. Furthermore, 74.3% of the respondents stated that their village had a local council, while 25.7% stated their villages lacked any council.

**Table 3** The economic, social, and environmental impacts of the soil conservation projects on farmers according to their statements. *Source:* Research findings (2019)

Consequences of the plan		Mean	Coefficient of variation	SD	Rank	t	Mean difference	Sig	Direction of the impact
Economic	Impact on the available resources	1.13	0.39	0.45	1	21.05	1.13	0.001	Significantly improved
	Impact on income	0.72	0.48	0.35	2	17.28	0.72	0.001	improved
	Impact on employment	0.66	0.86	0.57	3	9.78	0.66	0.001	improved
	Impact on loans	0.36	1.3	0.49	4	6.23	0.36	0.001	improved
	Impact on ownership and assets	0.14	3.7	0.53	5	2.23	0.14	0.02	improved
	Impact on savings	0.15	4.2	0.64	6	2	0.15	0.04	improved
	<b>Total economic impact</b>	<b>0.53</b>	<b>0.45</b>	<b>0.24</b>	<b>3</b>				
Sociocultural	Impact on the support of institutions	1.01	0.38	0.39	4	21.9	1.01	0.001	Significantly improved
	Impact on social justice	1.2	0.41	0.49	5	20.3	1.2	0.001	Significantly improved
	Impact on social welfare	1.07	0.35	0.38	3	23.7	1.07	0.001	Significantly improved
	Impact on participation	1.33	0.25	0.34	2	32.8	1.33	0.001	Significantly improved
	Impact on the communication and knowledge channels	1.2	0.21	0.25	1	39.6	1.2	0.001	Significantly improved
<b>Total sociocultural impact</b>	<b>1.16</b>	<b>0.17</b>	<b>0.19</b>	<b>1</b>					
Environmental		1.02	0.19	0.2		42.1	1.02	0.001	Significantly improved
	<b>Total environmental impact</b>	<b>1.02</b>	<b>0.19</b>	<b>0.2</b>	<b>2</b>				

**Table 4** The distribution of the consequences of the plan over the dimensions investigated in the current study using the difference between SD and Mean

The general consequence of the plan	Mean*	SD	High		Average		Low	
			Percent	Frequency	Percent	Frequency	Percent	Frequency
			Economic	0.53	0.24	25.7	18	48.6
Environmental	1.02	0.19	35.7	25	38.6	27	25.7	18
Social	1.16	0.19	31.4	22	48.6	34	20	14

\*The mean ranges between -2 and +2

## 4.2 The impacts of conservation projects

The economic impacts of the soil conservation projects indicate that the influence of the projects on the available resources was the most significant effect (Table 3). It pointed to the fact that proper use of certified seeds for cultivation, using up-to-date knowledge for tillage, and using experts' opinions in using combined tillage machinery can lead to the reduction of soil reduction. The economic impacts, such as the impact on income, employment, loans, land and machinery ownership, and finally savings, were ranked second. The impact on income, which ranked second, confirms the idea that the income of the respondents in the plan increased, and it can be regarded as an important impact. Nevertheless, the economic impact of the plan on the respondents' lives was not significantly high despite being positive.

The socioeconomic impacts showed that the impacts of the plan on communication and knowledge channels ranked first. This shows that the agricultural offices and the executors of the plan were successful in holding promotion classes and making farmers familiar with the advantages of soil conservation. In addition, the impacts of the plan on participation, social welfare and the support of institutions, and the impact of social justice on farmers ranked next. Furthermore, the environmental impacts indicated that the average and standard deviation of the impact of the plan on the environmental dimension were 1.02 and 0.2, respectively. Respondents emphasized the importance of leaving plant residues on the soil to reduce erosion, using integrated management methods to deal with blights, reducing the use of poison, and using animal fertilizer instead of chemical fertilizer as required by each plan.

In general, the priorities assigned to the economic, social, and environmental consequences in Table 3 indicate that the sociocultural influences of the plan on farmers' lives ranked first with the coefficient of variation equal to 0.17. The next strong consequence of the plan was related to the environmental dimensions with the coefficient of variation equal to 0.19.

Finally, the economic dimension had the lowest impact on the farmers' situation. This can be caused by floods over the past few years, which made the economic impacts seem weaker.

The one-sampled t-test was used to equate the average impacts of conservation agriculture. The average impacts were compared with 0, which was the standard and neutral value (Table 4). In case that the value of each impact was higher than 0 and showed a significant difference with the set value ( $0.01 \geq P^{**}$   $0.05 \geq P^*$ ), it was concluded that the implementation of the plan had had an increasing impact. On the other hand, when the

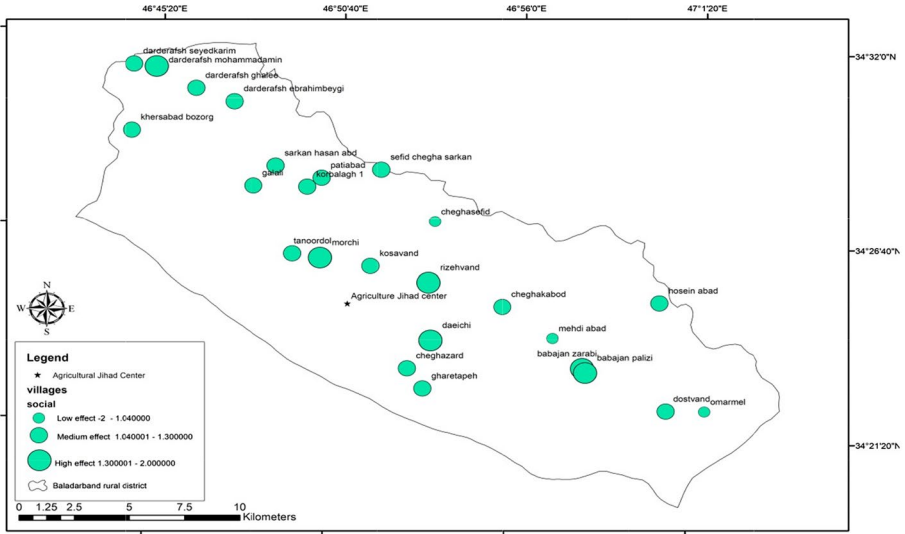

Fig. 4 The social consequences of the conservation plan in studied villages. Source: Research findings (2019)

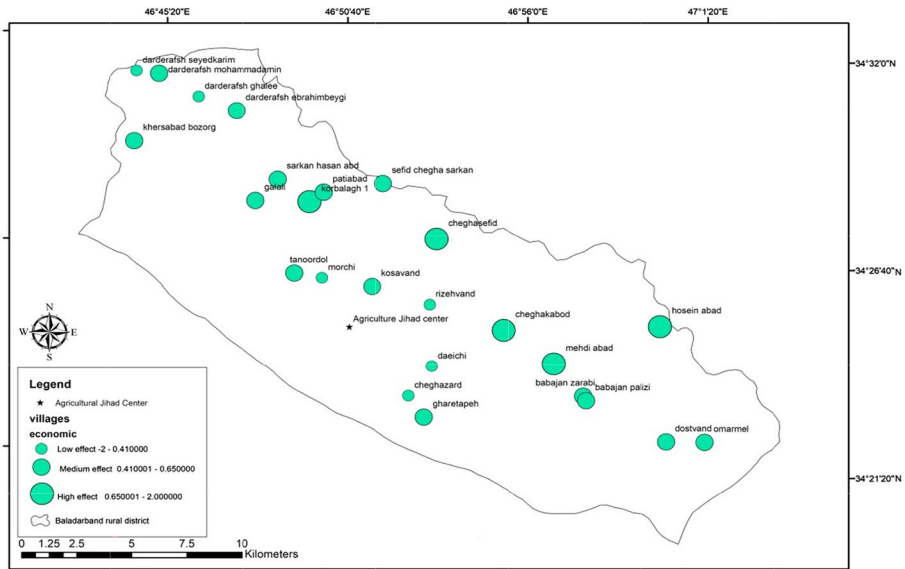
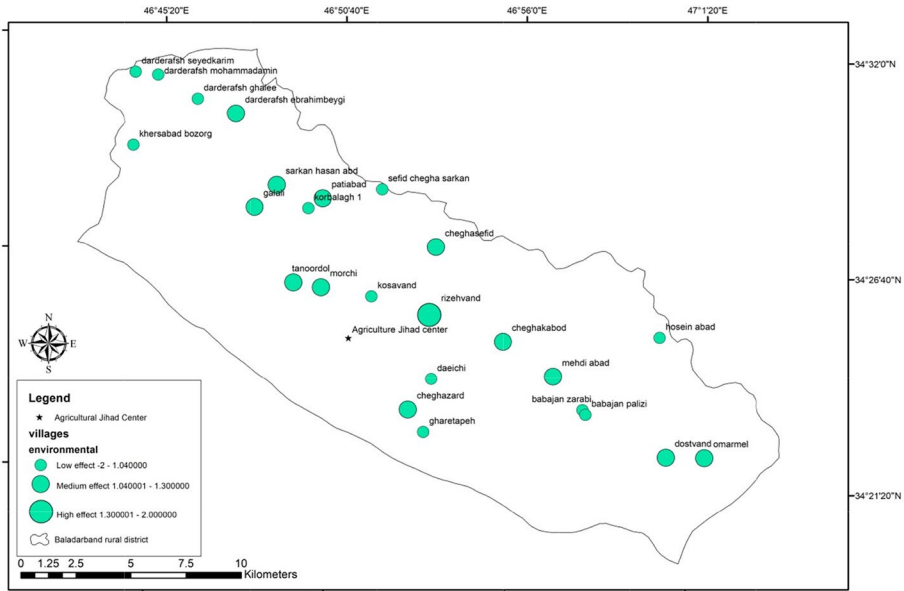

Fig. 5 The economic consequences of the conservation plan in studied villages. Source: Research findings (2019)

averages were below 0 and showed a significant difference with the set value ( $0.01 \geq P^{**}$   $0.05 \geq P^*$ ), it was concluded that the plan had made a decreasing impact on them.

Figures 4, 5, and 6 illustrate the spatial distribution and consequences of the conservation agriculture plan in terms of the social, economic, and environmental dimensions,



**Fig. 6** The environmental consequences of the conservation plan in studied villages. Source: Research findings (2019)

respectively. These results were divided into three levels (i.e., low, average, and high influence) based on the difference between Mean and SD.

Figure 4 shows the spatial distribution status of the social consequences of the conservation agriculture plan in studied villages. Social consequences are divided into three levels including low, medium, and high, based on the average distance from the mean value and the standard deviation. The distribution of data showed that the social consequences of the studied villages in all dimensions are at a medium and higher level (48.6% at the medium level and 31.4% at the high level), which shows the positive status of the social consequences of the project, based on respondents' point of view.

Figure 5 shows the spatial distribution of the economic consequences of the project. The results show that the status of economic consequences in the studied villages is at a medium and higher level (48.6% average and 25.7% high), indicating the positive status of the project's economic consequences. Although there has been a significant improvement in most economic dimensions, access to resources has the highest level of improvement, showing the role of supporting programs of the ICARDA team. These supporting services included supplying composite machinery, certified seeds for cultivation, agricultural education, and consultation with experts.

The results in Fig. 6 show that the situation of environmental consequences of studied villages is at a moderate and higher level of positive improvement (38.6% at the average level and 35.7% at the high level), showing a significant improvement in environmental indexes. Farmers' intention to use integrated pest management and natural methods to combat pests and diseases has increased as a result of conservation agricultural behavior, rather than using chemical pesticides and fertilizers.

**Table 5** The matrix of correlations between the constructs of the model. *Source:* Research findings (2019)

Constructs	Mean	SD	1	2	3	4	5
1. Conservation behavior	0.80	0.23	1				
2. Behavioral intention	3.47	0.92	0.533**	1			
3. Attitude towards conservation agriculture	4	0.44	0.368**	0.675**	1		
4. Mental norm	3.44	0.87	0.456**	0.772**	0.657**	1	
5. Behavioral control	3.83	0.59	0.509**	0.749**	0.695**	0.711**	1

\*Meaningful at 1 percent, \*\*meaningful at 5 percent

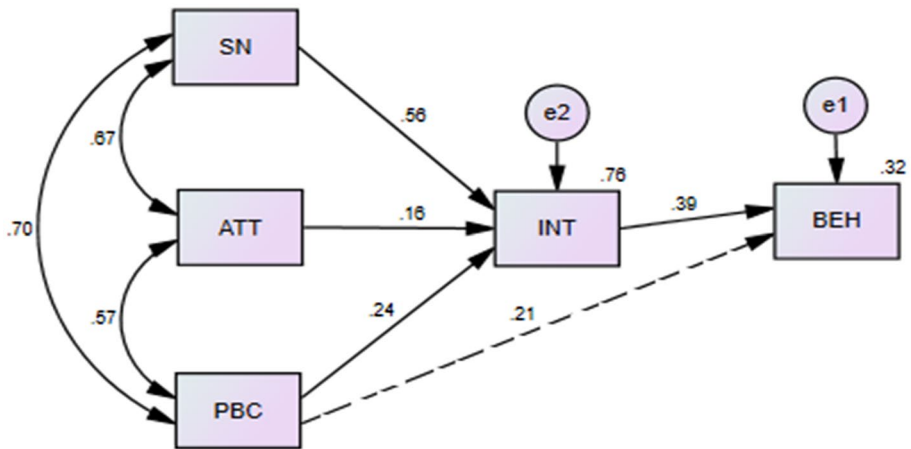

**Fig. 7** The path model of the direct and indirect impacts of the constructs on the conservation tillage behavior and the fitness indicators of the model. *Source:* Research findings (2019).  $\chi^2=0/150$ ,  $df=2$ ,  $\chi^2/df=0/075$ ,  $P=0.928$ ,  $RMR=0.001$ ,  $GFI=0.99$ ,  $NFI=0.99$ ,  $IFI=0.99$ ,  $TLI=0/98$ ,  $CFI=0.99$ ,  $RMSEA=0/001$

**4.3 Correlation between the research variables**

The correlation matrix for the investigated constructs has been provided in Table 5. The mean of the constructs indicates that most constructs are average or higher. As shown in the table, a significant relationship exists between behavioral intention, attitudes, mental norms, and perceived behavioral control and conservation agriculture. In other words, conservation behavior had a significant relationship with other variables including behavioral intention, attitude towards conservation agriculture, subjective norms, and behavioral control.

**4.4 Structural equation modeling (the path model)**

The impact of the theoretical constructs included in the TPB on the conservation tillage behavior of the farmers taking part in the study was investigated using structural

**Table 6** Testing the hypotheses

Research hypotheses based on the paths	Test of hypothesis	t-values
H1 Behavioral intention to perform conservation tillage → conservation tillage behavior	Confirmed	2.704**
H2 behavioral control → conservation tillage behavior	Rejected	1.473 <sup>ns</sup>
H3 Mental Norm → Intention to soil conservation	Confirmed	6.09**
H4 Attitudes towards soil conservation → intention to soil conservation	Rejected	2.039*
H5 Behavioral control → Intention to soil conservation	Confirmed	2.885**

equation modeling. First, the fitness of the model was tested. As can be observed, values obtained for GFI, IFI, TLI, CFI, and NFI are higher than 0.9, while the value for RMSEA was found to be below 0.08. In addition, the value of RMR was found to be below 0.05. The results of analyses showed that the value of Chi-square obtained in the ( $\chi^2/df=075/0$ ) model at the level of 0.9 was significant; thus, the insignificance condition of Chi-square was confirmed. Consequently, all variables involved in the overall fitness of the model were in an acceptable level and range. In other words, all values obtained for the fitness indicators were convenient, and the model applied in the current study has acceptance fitness. In the path model illustrated in Fig. 7, the non-significant paths have been specified using the dashed line. On the other hand, Table 6 provides the research hypotheses, which have been confirmed or rejected based on their significance.

The results of analyzing the path model showed that intention has a significant impact on farmers' conservation agriculture behavior ( $p=0.007$ ,  $\beta=0.392$ ). People act logically and think about the probable results and consequences of an action before performing it. In this theory, the intention is the immediate referent of any behavior and is called behavioral intention. It is expected that people will do whatever they intend to perform and act accordingly. As intentions become stronger, the chance of their actualization increases. However, the perceived behavioral control did not show any significant impact on farmers' conservation tillage behavior ( $\beta=0.214$ ,  $p=0.141$ ). An individual's behavioral control and personal beliefs can be assessed based on the ease or difficulty of acting. As people think that they have the required resources and opportunities and are faced with fewer obstacles and limitations increasingly, they will have more tangible control over their behavior. This lack of influence and significance indicates that farmers have behavioral control and beliefs regarding soil conservation, but some obstacles prevent them from demonstrating such behavior. Finally, it was found that 32% of the conservation behavior variance was accounted for by the perceived behavioral control and behavioral intention.

Furthermore, it was found that attitudes towards conserving soil and conservation agriculture ( $\beta=0.165$ ,  $p=0.041$ ) and perceived behavioral control ( $\beta=0.241$ ,  $p=0.004$ ) had a significant impact on behavioral intention. This shows that farmers' positive attitudes towards soil conservation and performing easy undertakings for conserving soil and the advantage of such behavior can directly influence farmers' intention to conserve soil and finally result in the demonstration of conservation behavior. Subjective norms ( $\beta=0.564$ ,  $p=0.001$ ) indicated significant impacts on farmers' intentions. It can be inferred that the acceptance of soil conservation by acquaintances, trustees, and experts can influence farmers' decisions to demonstrate conservation tillage behavior. Finally, attitudes, perceived behavioral control, and mental norms accounted for 76% of the variance of behavioral intention.

**Table 7** The analysis of the impacts of the variables involved in the conservation tillage behavior

Constructs	Direct impact	Indirect impact	Total impact	Priority of the impact
Behavioral intention towards soil conservation	0.392	-	-	1
Attitudes towards soil conservation	-	0.064	0.064	4
Mental norms towards soil conservation	-	0.221	0.221	3
Behavioral control towards soil conservation	0.214	0.092	0.092	2

(R<sup>2</sup>) SMC soil conservation or conservation tillage behavior 0.32

(R<sup>2</sup>) SMC intention to perform conservation tillage 0.76

In Table 7, the direct, indirect, and total impacts of the constructs on farmers' conservation tillage behavior have been presented. The behavioral intention or decision to perform conservation tillage was found to have the strongest influence on the behavior. According to the direct and indirect impact, as well as the total impact, it was found that this construct had the strongest influence and priority for the respondents in the selected region. In addition, the perceived behavioral control, subjective norms, and attitudes ranked next and indicated their importance in indirectly influencing conservation tillage behavior.

## 5 Discussion

The findings showed that the main consequence of the conservation tillage plan includes the social consequences (the effect of communication-knowledge channels, impacts on participation, impacts on welfare, impacts on supporting institutions, and impacts on social justice). The environmental and economic consequences were in the next ranks, respectively. In general, the impacts identified for the conservation tillage plan in the current study were in line with the findings obtained by Stevenson et al. (2014), Bhan and Behera (2014), Santos Telles et al. (2018), Pradhan et al. (2018), and Vastola et al. (2017). They concluded that conservation tillage will bring about multiple economic, socioeconomic, and environmental consequences for farmers, and these impacts can accelerate the adoption and development of conservation agriculture in rural areas.

The findings indicated that perceived behavioral control has a significant impact on conservation tillage behavior. It can be argued that when farmers understand that the principles of conservation tillage are easy to adopt, their intention to accept this method will be strengthened. This is in line with the studies conducted by Abadi et al. (2020), Bonke and Musshoff (2020), Tama et al. (2020), and Werner et al. (2017). They argued that if farms believe that performing a particular behavior is under their control, their behavioral intention will increase. In addition, if undertaking a behavior is not too complex for them, it can be expected that their intention to demonstrate that behavior will be strengthened.

Furthermore, attitude showed a significant impact on farmers' behavioral intentions. In other words, if farmers are aware of the consequences of conservation tillage and believe that the plan will lead to positive impacts on their agriculture and life, their intention to adopt the principles of conservation tillage will be strengthened. Some other scholars (e.g., Buyinza et al., 2020; Castillo et al., 2021; Doran et al., 2020; Janssen et al., 2020; Vaz et al., 2020) found that individuals' attitudes could play a major role in the processes of decision-making and the strengthening of the intention to adopt conservation agriculture.

The findings illustrated that subjective norms had a significant effect on the construct of behavioral intention, as well. It can be argued that when farmers feel the force of their society to adopt the conservation tillage plan, their behavioral intention for acceptance will increase. In other words, farmers are inclined to demonstrate behavior that is approved by their acquaintances. Studies conducted by Sahraei et al. (2018), Motalebani et al. (2020), Rafiei et al. (2016), Lalani et al. (2016), and Wauters et al. (2010) confirm this finding. They found that group compatibility forces individuals to demonstrate behavior similar to that of other members. In other words, people are inclined to demonstrate behavior that is approved by society.

In addition, the findings showed that behavioral intention has a significant impact on farmers' conservation tillage behavior. It can be argued that when farmers are mentally prepared to undertake conservation tillage, this plan will more likely be accepted by them. In other words, behavioral intention is the immediate forerunner of the appearance of a particular behavior, which is usually formed in people's minds. This was found to be in line with the findings of Wang and Lin (2020), Abadi et al. (2020), Tama et al. (2020), Werner et al. (2017), and Agharajabi (2018). They indicated that behavioral intention is an essential motivation and an underlying factor in the demonstration of individual behavior and is affected by attitudes, norms, and perceived behavioral control.

## 6 Conclusion

Soil is a living part of the Earth and the life of all creatures depends on it. However, its erosion is considered a major ecological and economic issue in agrarian and rural societies. Statistics indicate that 94% of the lands in our country are being destroyed and Iran ranks 2nd in the world in terms of soil erosion (with the highest rate of erosion in the western and north-western provinces). In this regard, changing cultivation systems can play a main role in the development of agriculture. For this purpose, conservation tillage has been introduced as a technique to conserve soil against erosion, maintain plant residues on lands to strengthen the soil, and keep the moisture of farmlands. A 25% increase in the production of wheat, barley, and chickpea has been projected for 2021 and the conservation tillage is among the major ways to achieve it. ICARDA has been working in Kermanshah province for several years, and since the beginning of this plan, more than 700 (ha) of dry-farming lands have been assigned for raising wheat, barley, and chickpea. If the plan is successful, it will be promising to be adopted in other areas of Iran. However, due to the changes in climate, drought, and rainfed agriculture, maintaining the moisture of the soil is quite important and essential. Thus, the main goal of the current study was to assess the consequences of performing conservation tillage towards the farmers' conservation behavior in the Sarab Niloofar rural district in Kermanshah, Iran.

The findings indicated that the TPB can predict the farmers' tillage behavior well, and its constructs play a major role in the farmers' intention and behavior. Therefore, it can be concluded that a major part of farmers' behavior is influenced by psycho-social characteristics. Nevertheless, most policymakers ignore the social and psychological dimensions and focus mainly on the economic and environmental factors. Thus, understanding farmers' social and psychological processes leading to the demonstration of conservation behavior can help policymakers in directing their insights and attitudes towards comprehensive plans and reduce uninformed decisions.

It is suggested that other farmers' attitudes should be changed toward the adoption of conservation tillage through extension-educational activities such as farm day, producing films and brochures, and documenting the experiences of farmers taking part in the conservation tillage plan. To facilitate this, establishing a rural think tank on conservation agriculture, which is only comprised of the farmers taking part in the plan, seems essential. However, the significant impact of behavioral intention on farmers' conservation tillage behavior indicates that undertaking such activities should become a priority for policymakers; this is because farmers consider intention and decision towards a particular behavior before actually performing it, and failure in introducing and emphasizing the importance of tillage and its positive consequences can make obstacles against the demonstration of their conservation behavior.

Since all constructs related to the social dimensions enhanced significantly in the current study and indicated the significant social capital of the plan among the local population, the potential of this great capital should not be ignored and the capacity of the rural councils, village chiefs, local trustees, and promotion agents have to be exploited. These undertakings will certainly influence farmers' mental norms and attitudes, and these factors, in turn, will impact decisions towards the adoption of conservation tillage and finally the demonstration of such behavior. Furthermore, the financial assistance of governments in the form of loans to purchase convenient machinery for the conservation tillage can portray a promising future for this plan.

In conclusion, this study fills a significant research gap by evaluating the consequences of protective tillage projects and investigating farmers' behavior during their implementation. The findings of this study offer several valuable managerial implications and insights for policymakers, practitioners, and extension agencies in the field of sustainable agriculture. Firstly, the study highlights the importance of considering the social, environmental, and economic factors when designing and implementing protective tillage projects. Policymakers and practitioners should prioritize these factors to ensure the desired outcomes of such projects. By focusing on income generation, employment opportunities, and improved social welfare, protective tillage projects can effectively contribute to the well-being of farming communities. Secondly, the study emphasizes the need to foster community participation and communication within the region. Creating platforms for farmers to engage and collaborate not only enhances the implementation of protective tillage practices but also promotes knowledge sharing, innovation, and social cohesion among farmers. Extension agencies play a crucial role in facilitating these collaborative efforts and should actively involve farmers in decision-making processes related to soil conservation projects. Furthermore, the study underscores the importance of addressing farmers' mental norms, attitudes, and perceived behavioral control in promoting the adoption of protective tillage practices. Policymakers and practitioners should develop targeted interventions that aim to positively influence farmers' beliefs and perceptions regarding the benefits and feasibility of implementing protective tillage systems. This can be achieved through awareness campaigns, training programs, and financial incentives that address the specific barriers and concerns faced by farmers. Overall, this study provides valuable insights for managerial decision-making in promoting sustainable agriculture through protective tillage projects. By considering the social, environmental, and economic dimensions, fostering community participation, and addressing farmers' behavioral factors, policymakers, practitioners, and extension agencies can effectively support the adoption and implementation of protective tillage practices, leading to long-term sustainability in agriculture. Albeit the research broadened our comprehension of farmers' behavior to participate in soil conservation projects, it has some specific impediments that should be spotted in ongoing studies.

This research was only investigated in one province of Iran. Thus, the outcomes of this study cannot be attributed to all farmers in all provinces. Subsequently, what is presently required is a cross-public study including examples from different provinces that can assist with announcing summed-up outcomes. The main restrictions of the study incorporate geological vastness and scattering, acquiring the farmers' trust, and the absence of inspiration among the farmers, just as the absence of research on the outcomes of conservation agriculture in Iran. Future exploration should incorporate widening the range of empirical occasions to prove the certifiable framework. Furthermore, success components and obstacles to the adoption of agricultural conservation should be investigated. Future research could compare the paradigmatic model to other behavioral theories in order to determine how to first integrate approaches and frameworks with legislative and rural community endeavors in order to shift production approaches toward sustainability. Finally, a crucial question for further research will be how farmers' conservation behavior can be measured in addition to farmers' self-reports.

**Acknowledgements** Not applicable.

**Author contributions** AYF and SHN performed the study and developed the main text. KS, PA, KNM, and HA contributed to the first draft manuscript and enriched it up to the final version.

**Funding** This research did not receive any specific grant from funding agencies in the public, commercial, or not-for-profit sectors.

**Availability of data and material/Data availability** Once the manuscript is accepted, the data will be archived in the repository of the Bu-Ali Sina University and a link will be made available.

## Declarations

**Conflict of interest** The authors declare no conflict of interest.

**Code availability** Not applicable.

## References

- Abadi, B., Yadollahi, A., Bybordi, A., & Rahmati, M. (2020). The contribution of diverse motivations for adhering to soil conservation initiatives and the role of conservation agriculture features in decision-making. *Agricultural Systems*, *182*, 102849.
- Abbasi, S., Daneshmand-Mehr, M., & Ghane Kanafi, A. (2022). Designing sustainable recovery network of end-of-life product during the COVID-19 pandemic: A real and applied case study. *Discrete Dynamics in Nature and Society*, *2022*, 1–2.
- Abbasi, S., Daneshmand-Mehr, M., & Ghane Kanafi, A. (2023). Green closed-loop supply chain network design during the coronavirus (COVID-19) pandemic: A case study in the Iranian Automotive Industry. *Environ Model and Assess*, *28*(1), 69–103.
- Abbasi, S., Daneshmand-Mehr, M., & Ghane Kanafi, A. (2021). The sustainable supply chain of CO<sup>2</sup> emissions during the coronavirus disease (COVID-19) pandemic. *Journal of Industrial Engineering and Management*, *17*(4), 83–108.
- Abbasi, S., & Erdebilli, B. (2023). Green closed-loop supply chain networks' response to various carbon policies during COVID-19. *Sustainability*, *15*(4), 3677.
- Abdollahpour, S., & Karparvarfard, S. H. (2017). Field evaluation of a grain drill equipped with jointers for direct planting in previous wheat crop residues. *Iran Agricultural Research*, *36*(2), 23–30.
- Abidin, I. S. Z., Haseeb, M., & Islam, R. (2022). Impact of agricultural irrigated land and raw material import, labor force and capital formation on rice production: Evidence from the Malaysian economy. *Cuadernos De Economia*, *45*(127), 106–112.

- Agharajabi, S. (2018). Investigating factors affecting adoption of soil conservation measures within farmers in chel-chaay watershed, Golestan province. Thesis is approved for the degree of Master of Sciences in Agriculture Extension and Education. Agricultural Management, Gorgan University of Agricultural Sciences and Natural Resources. (In Persian).
- Ajzen, I. (1991). The theory of planned behavior. *Organizational Behavior and Human Decision Processes*, 50(2), 179–211.
- Akinyemi, F. O., Ghazaryan, G., & Dubovyk, O. (2021). Assessing UN indicators of land degradation neutrality and proportion of degraded land for Botswana using remote sensing based national level metrics. *Land Degradation and Development*, 32(1), 158–172.
- Albertengo, J., Belloso, C., Giraudo, M. B., Peiretti, R., Permingeat, H., & Wall, L. (2014). Conservation agriculture in Argentina. In R. A. Jat, K. L. Sahrawat, & A. H. Kassam (Eds.), *Conservation agriculture: Global prospects and challenges* (pp. 352–374). CAB International.
- Anghinoni, G., Godinho Anghinoni, F. B., Tormena, C. A., Braccini, A. L., Mendes, I. D. C., Zancanaro, L., & Lal, R. (2021). Conservation agriculture strengthens sustainability of Brazilian grain production and food security. *Land Use Policy*, <https://doi.org/10.1016/j.landusepol.2021.105591>.
- Ashoori, D., Allahyari, M. S., & Damalas, C. A. (2017). Adoption of conservation farming practices for sustainable rice production among small-scale paddy farmers in northern Iran. *Paddy and Water Environment*, 15(2), 237–248.
- Ataei, P., Sadighi, H., Chizari, M., & Abbasi, E. (2019). Analysis of farmers' social interactions to apply principles of conservation agriculture in Iran: Application of social network analysis. *Journal of Agriculture, Science and Technology*, 21(7), 1657–1671.
- Ataei, P., Sadighi, H., Chizari, M., & Abbasi, E. (2020). In-depth content analysis of conservation agriculture training programs in Iran based on sustainability dimensions. *Environment, Development and Sustainability*, 22(8), 7215–7237.
- Ataei, P., Sadighi, H., Aenis, T., Chizari, M., & Abbasi, E. (2021). Challenges of applying conservation agriculture in Iran: An overview on experts and farmers perspectives. *Air, Soil and Water Research*, 14, 1–12.
- Bhan, S., & Behera, U. K. (2014). Conservation agriculture in India-Problems, prospect and policy issues. *International Soil and Water Conservation Research*, 2(4), 1–12.
- Blanco-Sepúlveda, R., Enríquez-Narváez, F., & Cueto, F.J.L. (2021). Effectiveness of conservation agriculture (tillage vs. vegetal soil cover) to reduce water erosion in maize cultivation (*Zea mays* L.): An experimental study in the sub-humid uplands of Guatemala. *Geoderma*, <https://doi.org/DOI:10.1016/j.geoderma.2021.115336>.
- Bonke, V., & Musshoff, O. (2020). Understanding German farmer's intention to adopt mixed cropping using the theory of planned behavior. *Agronomy for Sustainable Development*, 40, 6.
- Bouwman, T. I., Andersson, J. A., & Giller, K. E. (2021). Adapting yet not adopting? Conservation agriculture in Central Malawi. *Agriculture, Ecosystems and Environment*, 307.
- Brown, B., Llewellyn, R., & Nuberg, I. (2018). Why do information gaps persist in African smallholder agriculture? Perspectives from farmers lacking exposure to conservation agriculture. *The Journal of Agricultural Education and Extension*, 24(2), 191–208.
- Brown, B., Nuberg, I., & Llewellyn, R. (2017). Stepwise frameworks for understanding the utilisation of conservation agriculture in Africa. *Agricultural Systems*, 153, 11–22.
- Brown, B., Nuberg, I., & Llewellyn, R. (2020). From interest to implementation: Exploring farmer progression of conservation agriculture in Eastern and Southern Africa. *Environment, Development and Sustainability*, 22(4), 3159–3177.
- Buyinza, J., Nuberg, I. K., Muthuri, C. W., & Denton, M. D. (2020). Assessing smallholder farmers' motivation to adopt agroforestry using a multi-group structural equation modeling approach. *Agroforestry Systems*, 94(6), 2199–2211.
- Castillo, G. M. L., Engler, A., & Wollni, M. (2021). Planned behavior and social capital: Understanding farmers' behavior toward pressurized irrigation technologies. *Agricultural Water Management*, 243, 106524.
- Chatterjee, R., & Acharya, S. K. (2021). Dynamics of conservation agriculture: a societal perspective. *Biodiversity and Conservation*, 30, 1–21.
- Derrouch, D., Chauvel, B., Cordeau, S., & Dessaint, F. (2021). Functional shifts in weed community composition following adoption of conservation agriculture. *Weed Research*, <https://doi.org/10.1111/wre.12517>.
- Doran, E. M. B., Zia, A., Hurley, S. E., Tsai, Y., Koliba, C., Adair, C., et al. (2020). Social-psychological determinants of farmer intention to adopt nutrient best management practices: Implications for resilient adaptation to climate change. *Journal of Environmental Management*, 276, 111304.

- Food and Agriculture Organization of the United Nations. (FAO). (2013). Conservation Agriculture in central Asia: status, policy, institutional support and strategic framework for its promotion. E-ISBN 978-92-5-107637-8 (PDF).
- FAO & ITPS. (2015). Status of the world's soil resources (SWSR)—main report. J Food agriculture organization of the United Nations intergovernmental technical panel on soils, Rome, Italy, 650.
- Friedrich, T., Kienzie, J., & Kassam, A. H. (2009). Conservation agriculture in developing countries: the role of mechanization. In *Club of Bologna meeting on innovation for sustainable mechanisation, Hanover, Germany, 2nd November*.
- Fuentes-Llanillo, R., Telles, T. S., Soares Junior, D., de Melo, T. R., Friedrich, T., & Kassam, A. (2021). Expansion of no-tillage practice in conservation agriculture in Brazil. *Soil and Tillage Research*, 208, 104877.
- Gao, L., Wang, S., Li, J., & Li, H. (2017). Application of the extended theory of planned behavior to understand individual's energy saving behavior in workplaces. *Resources, Conservation and Recycling*, 127, 107–113.
- Ghanbari, S., Bazrafshan, J., Toulabinejad, M., & Toulabinejad, M. (2018). The factors influencing decisions of farmers in applying soil and water resource protection methods in Jaidar Plain, Poldokhtar. *Human Geography Research*, 50(1), 73–92.
- Ghosh, B. N., Dogra, P., Sharma, N. K., Bhattacharyya, R., & Mishra, P. K. (2015). Conservation agriculture impact for soil conservation in maize–wheat cropping system in the Indian sub-Himalayas. *International Soil and Water Conservation Research*, 3(2), 112–118.
- Hair, J. F., Sarstedt, M., Ringle, C. M., & Gudergan, S. (2018). *Advanced issues in partial least squares structural equation modeling*. New York: SAGE Publications Inc.
- He, Y. (2023). Characteristics and advantages of traditional agricultural economy. In *The agricultural civilization of ancient China* (pp. 19–36). Springer.
- Hekmatnia, M., Ardakani, A. F., Isanezhad, A., et al. (2023). A novel classification of virtual water trade for the sustainability of global freshwater resources. *Environment, Development and Sustainability*. <https://doi.org/10.1007/s10668-023-03012-7>
- Holden, S. T., Fisher, M., Katengeza, S. P., & Thierfelder, C. (2018). Can lead farmers reveal the adoption potential of conservation agriculture? The case of Malawi. *Land Use Policy*, 76, 113–123.
- Huang, X., Wang, L., & Lu, Q. (2018). Vulnerability assessment of soil and water loss in Loess Plateau and its impact on farmers' soil and water conservation adaptive behavior. *Sustainability*, 10(12), 4773.
- ICARDA. (2016). Brief ICARDA Strategy 2017–2026. 2016. International Center for Agricultural Research in the Dry Areas. [www.icarda.org/sites/default/files/ICARDA\\_STRATEGY\\_BRIEF](http://www.icarda.org/sites/default/files/ICARDA_STRATEGY_BRIEF)
- ICARDA. (2017). Enhancing resilience: helping dryland communities to thrive. ICARDA Annual Report 2016. International Center for Agricultural Research in the Dry Areas Beirut Lebanon.
- Janssen, E. M., Mourits, M. C. M., van der Fels-Klerx, H. J., & Oude Lansink, A. G. J. M. (2020). Factors underlying Dutch farmers' intentions to adapt their agronomic management to reduce Fusarium species infection in wheat. *PLoS ONE*, 15(9), e0237460.
- Jat, H.S., Datta, A., Madhu Choudhary, M., Sharma, P.C., Dixit, B., & Jat, M.L. (2021). Soil enzymes activity: Effect of climate smart agriculture on rhizosphere and bulk soil under cereal based systems of north-west India. *European Journal of Soil Biology*, <https://doi.org/10.1016/j.ejsobi.2021.103292>.
- Karani, Z., Shiri, N., & Salehi, L. (2014). Attitude of farmers to soil conservation practices (SCPs) in Kermanshah Province. *Iranian Journal of Agricultural Economics and Development Research*, 45(1), 143–154.
- Kassam, A., Friedrich, T., Derpsch, R., & Kienzie, J. (2015). Overview of the worldwide spread of conservation agriculture. Field actions science reports. *The Journal of Field Actions*, 8, 1–11.
- Kicińska, A., & Wikar, J. (2021). Ecological risk associated with agricultural production in soils contaminated by the activities of the metal ore mining and processing industry-example from southern Poland. *Soil and Tillage Research*, 205, 104817.
- Kifle, S., Teferi, B., Kebedom, A., & Abiyot, L. (2016). Factors influencing farmers decision on the use of introduced soil and water conservation practices in the Lowland's of Wenago Woreda, Gedeo Zone, Ethiopia. *American Journal of Rural*, 4(1), 24–30.
- Komarek, A.M., Dunston, S., Enahoro, D., Godfray, H.C.J., Herrero, M., Sulser, T.B., & Wiebe, K.D. (2021). Income, consumer preferences, and the future of livestock-derived food demand. *Global Environmental Change*, <https://doi.org/10.1016/j.gloenvcha.2021.102343>.
- Lalani, B., Dorward, P., Holloway, G., & Wauters, E. (2016). Smallholder farmers' motivations for using conservation agriculture and the roles of yield, labour and soil fertility in decision making. *Agricultural Systems*, 146, 80–90.
- Latifi, S., Raheli, H., Yadavar, H., & Saadi, H. (2017a). Analysis of the barriers to development of conservation agriculture in Iran. *Journal of Sustainable Agricultural Sciences*, 26(4), 167–184. In Persian.

- Latifi, S., Raheli, H., Yadavar, H., & Saadi, H. (2017b). Identification and analysis of driving factors of conservation agriculture development in Iran. *Iranian Agricultural Extension and Education Journal*, 13(1), 105–125. In Persian.
- Latifi, S., Raheli, H., Yadavar, H., & Saadi, H. (2018). Designing a process model for conservative agriculture development in Iran: Using interpretive structural modeling approach. *Iranian Journal of Agricultural Economics and Development Research*, 49(1), 105–120.
- Lienhard, P., Boulakia, S., Legoupil, J.-C., Gilard, O., & Séguy, L. (2014). Conservation agriculture in South-east Asia. In R. A. Jat, K. L. Sahrawat, & A. H. Kassam (Eds.), *Conservation agriculture: Global prospects and challenges* (pp. 180–201). CAB International.
- Mamani, W. C., Manrique, G. M. L., Madrid, S. D. P. C., Herrera, E. E., Acosta, D. B., Rivas-Diaz, R. R., & Ramos, F. S. S. (2022). The role of entrepreneurship and green innovation intention on sustainable development: Moderating impact of inclusive leadership. *Agric Biological Forum*, 24(1).
- Mango, N., Siziba, S., & Makate, C. (2017). The impact of adoption of conservation agriculture on smallholder farmers' food security in semi-arid zones of southern Africa. *Agriculture and Food Security*, 6(1), 1–8.
- Mao, D., Wang, Z., Wu, B., Zeng, Y., Luo, L., & Zhang, B. (2018). Land degradation and restoration in the arid and semiarid zones of China: Quantified evidence and implications from satellites. *Land Degradation and Development*, 29(11), 3841–3851.
- Mgolozeli, S., Nciizah, A. D., Wakindiki, I. I. C., & Mudau, F. N. (2020). Innovative pro-smallholder farmers' permanent mulch for better soil quality and food security under conservation agriculture. *Agronomy*, 10(4), 605.
- Mohammadi, S., Karimzadeh, H., & Alizadeh, M. (2018). Spatial estimation of soil erosion in Iran using RUSLE model. *Iranian Journal of Ecohydrology*, 5(2), 551–569.
- Momeni, D., Hayati, B., Dashti, G., & Rezaei, A. (2012). Factors affecting the adoption of soil mechanical conservation practices in dry lands of the Izeh Township. *Iranian Journal of Agricultural Economics and Development Research*, 42–2(4), 513–524.
- Motalebani, S., Zibaei, M., & Sheikhzeinoddin, A. (2020). Socio-economic factors influencing the adoption of conservation tillage technology. *Iranian Journal of Agricultural Economics and Development Research*, 51(1), 33–49.
- Mousavi Boogar, A. A., Jahansouz, M., Mehrvar, M., Hosseiniapur, R., & Madadi, M. (2012). Study the soil physical properties and some wheat cultivars grain yield under different tillage systems. *Journal of Agro and Plant Breeding*, 8(2), 11–20.
- Mugandani, R., & Mafongoya, P. (2019). Behaviour of smallholder farmers towards adoption of conservation agriculture in Zimbabwe. *Soil Use and Manage*, 35(4), 561–575.
- Mutuku, J.M., Cui, S., Yoshida, S., & Shirasu, K. (2021). Orobanchaceae parasite–host interactions. *New Phytologist*, <https://doi.org/10.1111/nph.17083>.
- Nawaz, A., Farooq, M., Ul-Allah, S., Gogoi, N., Lal, R., & Siddique, K. H. (2021). Sustainable soil management for food security in South Asia. *Journal of Soil Science and Plant Nutrition*, 21(1), 258–275.
- Ndah, H. T., Probst, L., Kaweesa, S., Kuria, P., Mkomwa, S., Rodrigues, P., et al. (2020). Improving farmers' livelihoods through conservation agriculture: options for change promotion in Laikipia, Kenya. *International Journal of Agricultural Sustainability*, 18(3), 212–231.
- Nguyen-Chi, H., Chuong, H. N., Pham-My, D., Nguyen-Anh, T., & Tra-Van, T. (2022). spatial clustering of manufacturing firms in Vietnam. *International Journal of Economics and Finance*, 14(1), 116–137.
- Nurbekov, A., Akramkhanov, A., Lamers, J., Kassam, A., Friedrich, T., Gupta, R., & Bekenov, M. (2014). Conservation agriculture in Central Asia. In R. A. Jat, K. L. Sahrawat, & A. H. Kassam (Eds.), *Conservation agriculture: Global prospects and challenges* (pp. 223–247). CAB International.
- Olawuyi, S. O., & Mushunje, A. (2020). Information acquisition and adoption of conservation agriculture by smallholder farmers in South-West Nigeria: Recursive bivariate probit estimation. *African Journal of Science, Technology, Innovation and Development*, 12(6), 715–725.
- Ouyang, R., Mu, E., Yu, Y., Chen, Y., Hu, J., Tong, H., & Cheng, Z. (2022). Assessing the effectiveness and function of the water resources tax policy pilot in China. *Environment, Development and Sustainability*. <https://doi.org/10.1007/s10668-022-02667-y>
- Panyasing, S., Yongvanit, S., Purnomo, E. P., Tham, I., & Aim, S. (2022). The government policy on the organic rice farming groups embracing sustainable agricultural production: Evidence in Thailand. *Agr Bio Forum*, 24(1), 83–94.
- Parwada, C., & Marufu, H. (2023). Digitalisation of agriculture in Zimbabwe: Challenges and opportunities. *International Journal of Sustainable Agricultural Research*, 10(1), 32–41. <https://doi.org/10.18488/ijrsar.v10i1.3280>

- Porhemmat, M. S., Porhemmat, J., & Mirzaee, M. (2020). Investigation on drought impact on the depletion of spring discharge in western parts of Iran. *Journal of Water Engineering and Management*, *12*(4), 1040–1054. In Persian.
- Pradhan, A., Chan, C., Kumar Roul, P., Halbrendt, J., & Sipes, B. (2018). Potential of conservation agriculture (CA) for climate change adaptation and food security under rainfed uplands of India: A transdisciplinary approach. *Agricultural Systems*, *163*, 27–35.
- Qin, C., Tang, Z., Chen, J., & Chen, X. (2020). The impact of soil and water resource conservation on agricultural production—an analysis of the agricultural production performance in Zhejiang, China. *Agricultural Water Management*, *240*, 106268.
- Rafei, L. (2016). A Study on the role of knowledge, attitudes and information resources of Wheat Farmers in the adoption of conservation tillage (A Case Study of Arak County, Iran). *Iranian Journal of Agricultural Economics and Development*, *46*(4), 645–654.
- Rahayu, D. N., Purnomo, S. H., & Sutrisno, J. (2023). The influence of farmers' business behavior in achieving success with integrated paddy and beef cattle agricultural systems in Indonesia. *Asian Journal of Agriculture and Rural Development*, *13*(1), 16–24.
- Razafimahatratra, H. M., Bignebat, C., David-Benz, H., Bélières, J. F., & Penot, E. (2021). Tryout and (Dis)adoption of conservation agriculture. Evidence from Western Madagascar. *Land Use Policy*, *100*.
- Reimer, A., Doll, J. E., Boring, T. J., & Zimmnick, T. (2023). Scaling up conservation agriculture: An exploration of challenges and opportunities through a stakeholder engagement process. *Journal of Environmental Quality*, *52*(3), 465–475.
- Rezaei-Moghaddam, K., Sabour, L., & Menati-Zadeh, M. (2017). Factors influencing adoption of soil conservation practices among farmers in Garmsar County, Iranian. *The Journal of Agricultural Education and Extension*, *13*(1), 59–73. In Persian.
- Richards M., Sapkota T., Stirling C., Thierfelder C., Verhulst, N., Friedrich T., & Kienzle, J. (2014). Conservation agriculture: Implementation guidance for policymakers and investors Climate-Smart Agriculture Practice Brief. CGIAR Research Program on Climate Change Agriculture and Food Security (CCAFS), Copenhagen.
- Sahraei, F., Rezvanfar, A., & Alambaygi, A. (2018). Development of a structural model of conservation agricultural technology among wheat producers in ilam province based on variables of social capital and social perception. *Agricultural Extension and Education Research*, *11*(2), 41–49.
- Sahu, G., Mohanty, S., & Das, S. (2020). Conservation agriculture—a way to improve soil health. *Journal of Experimental Biology and Agricultural Sciences*, *8*(4), 355–368.
- Santos Telles, T., Philip Reydon, B., & Gori Maia, A. (2018). Effects of no-tillage on agricultural land values in Brazil. *Land Use Policy*, *76*, 24–129.
- Satria, H., Amar, S., & Wardi, Y. (2022). Impact of Nagari financial management on the performance of sustainable development in west Sumatra Province, Croatian. *International Relations Rev*, *28*(90), 288–310.
- Serbaji, M. M., Bouaziz, M., & Weslati, O. (2023). Soil Water erosion modeling in Tunisia using RUSLE and GIS integrated approaches and Geospatial Data. *Land*, *12*(3), 548.
- Seifi, R., Chizari, M., & Abbasi, E. (2018). Factors affecting farmers' soil conservation behavior in West Azerbaijan Province: A cultural approach. *Iranian Agricultural Extension and Education Journal*, *13*(2), 219–234. In Persian.
- Shahriyari Garaei, M. (2012). *Application planned behavior theory in analysis of the factors effecting adoption of the no-tillage cultivation in Marvdasht County, thesis is approved for the degree of master of sciences in agriculture economic (Farm Management)*. University of Tabriz. In Persian.
- Shamabadi, Z. (2015). Study the effect of conservation tillage on fuel consumption productivity and rain-fed wheat yield. *Iranian Dryland Agronomy Journal*, *4*(1), 17–28. In Persian.
- Sousa, J., Rodrigues, P., & Basch, G. (2020). Social categories and agency within a conservation agriculture framework in Laikipia, Kenya. *International Journal of Agricultural Sustainability*, *18*(6), 554–566.
- Stašek, J., Krása, J., Mistr, M., Dostál, T., Devátý, J., Středa, T., & Mikulka, J. (2023). Using a rainfall simulator to define the effect of soil conservation techniques on soil loss and water retention. *Land*, *12*(2), 431.
- Stevenson, J. R., Serraj, R., & Cassman, K. G. (2014). Evaluating conservation agriculture for small-scale farmers in Sub-Saharan Africa and South Asia. *Agriculture, Ecosystems and Environment*, *187*, 1–10.
- Tambet, H., & Stopnitzky, Y. (2021). Climate Adaptation and Conservation Agriculture among Peruvian Farmers. *American Journal of Agricultural Economics*, <https://doi.org/10.1111/ajae.12177>.
- Taqi Ghulam, S., & Abushammala, H. (2023). Challenges and opportunities in the management of electronic waste and its impact on human health and environment. *Sustainability*, *15*, 1837.

- Tama, R. A. Z., Ying, L., Yu, M., Hoque, M. M., Adnan, K. M., & Sarker, S. A. (2020). Assessing farmers' intention towards conservation agriculture by using the extended theory of planned behavior. *Journal of Environmental Management*. <https://doi.org/10.1016/j.jenvman.2020.111654>
- Toulabinejad, M., Ghanbari, S., Dosti Moghadam, F., & Barawoi, M. (2017). Studying key effective economic and social factors for agricultural investment in sustainable management in agricultural areas (Case of the Study: The East Miankoh district). *Journal of Rural Development Strategies*, 4(4), 493–513.
- Van Hoa, N., Duyen, N. T. H., Huyen, V. N., Quang, H. V., Van Huong, N., Tu, N. T. C., & Nguyet, B. T. M. (2022). Impact of trained human resources, adoption of technology and international standards on the improvement of accounting and auditing activities in the agricultural sector in Viet Nam. *Agriculture Biological Forum*, 24(1), 59–71.
- Vastola, A., Zdruli, P., D'Amico, M., Pappalardo, G., Viccaro, M., Di Napoli, F., & Romano, S. (2017). A comparative multidimensional evaluation of conservation agriculture systems: A case study from a Mediterranean area of Southern Italy. *Land Use Policy*, 68, 326–333.
- Vaz, E. D., Gimenes, R. M. T., & Borges, J. A. R. (2020). Identifying socio-psychological constructs and beliefs underlying farmers' intention to adopt on-farm silos. *NJAS Wageningen Journal of Life Sciences*, 92, 1–8.
- Wang, M. Y., & Lin, S. M. (2020). Intervention strategies on the wastewater treatment behavior of swine farmers: An extended model of the theory of planned behavior. *Sustainability*, 12(17), 6906.
- Wang, W., & Wang, Y. (2022). Research on image capture technology of intelligent terminal and multi exposure fusion to improve the resilience of agriculture production systems. *Journal of Commercial Biotechnology* 27(2).
- Wauters, E., Bielders, C., Poesenc, J., Govers, G., & Mathijs, E. (2010). Adoption of soil conservation practices in Belgium: An examination of the theory of planned behaviour in the agri-environmental domain. *Land Use Policy*, 27, 86–94.
- Werner, M., Wauters, E., Bijttebier, J., Steinmann, H. H., Ruyschaert, G., & Knierim, A. (2017). Farm level implementation of soil conservation measures: Farmers' beliefs and intentions. *Renewable Agriculture and Food System*, 32(6), 524–537.
- Weston, R., & Gore, P. A., Jr. (2006). A brief guide to structural equation modeling. *The Counseling Psychol*, 34(5), 719–751.
- Yang, X., & Sang, Y. (2020). How does part-time farming affect farmers' adoption of conservation agriculture in Jiangnan plain, China? *International Journal of Environmental Research and Public Health*, 17(16), 1–12.
- Zhang, Q., Wang, S., Sun, Y., Zhang, Y., Li, H., Liu, P., & Li, J. (2022). Conservation tillage improves soil water storage, spring maize (*Zea mays* L.) yield and WUE in two types of seasonal rainfall distributions. *Soil and Tillage Res*, 215, 105237.
- Zhou, Z., Liu, J., Zeng, H., Zhang, T., & Chen, X. (2020). How does soil pollution risk perception affect farmers' pro-environmental behavior? The role of income level. *Journal of Environmental Management*, 270, 110806.

**Publisher's Note** Springer Nature remains neutral with regard to jurisdictional claims in published maps and institutional affiliations.

Springer Nature or its licensor (e.g. a society or other partner) holds exclusive rights to this article under a publishing agreement with the author(s) or other rightsholder(s); author self-archiving of the accepted manuscript version of this article is solely governed by the terms of such publishing agreement and applicable law.

## Authors and Affiliations

Ahmad Yaghoubi Farani<sup>1</sup> · Saeid Hedayati Nia<sup>1</sup> · Karwan Shanazi<sup>1</sup> · Pouria Ataie<sup>2</sup> · Karim Naderi Mahdei<sup>1</sup> · Hossein Azadi<sup>3</sup>

✉ Ahmad Yaghoubi Farani  
yaghoubi@basu.ac.ir

<sup>1</sup> Faculty of Agriculture, Bu-Ali Sina University, Hamedan, Iran

<sup>2</sup> Faculty of Agricultural Extension and Education, Tarbiat Modarres University, Tehran, Iran

<sup>3</sup> Department of Economic and Rural Development, Gembloux Agro-Bio Tech, University of Liège, Gembloux, Belgium