

Hybrid power solution modelling based on artificial intelligence

Antonin COLOT
ULiège - Belgium
antonin.colot@uliege.be

Bertrand BASTIN
CE+T Power
b.bastin@cet-energrid.com

Bastien EWBANK
ULiège - Belgium
bastien.ewbank@uliege.be

Fabrice FREBEL
CE+T Power
f.frebel@cet-power.com

Benoit BIDAINE
CE+T Power
b.bidaine@cet-power.com

Bertrand CORNÉLUSSE
ULiège - Belgium
bertrand.cornelusse@uliege.be

ABSTRACT

Power electronics become increasingly resourceful as the use of renewable energies increases. Microgrids and active distribution networks include various controllable devices that interact and may create instabilities. This underlines the necessity of modeling complex systems to conduct system-level analyses. As a first step toward tools for modeling inverter-based electrical systems, this paper introduces a model of the HyPoSol system, put in perspective with measurements on the real system. The HyPoSol system consists of a photovoltaic (PV) inverter, a battery, and a three-port converter designed by CE+T Power. To develop a model of the PV inverter, we employed an enhanced polytopic model which uses neural networks as weighting functions. The PV inverter model is combined with a Tremblay's battery model and a simplified model of the three-port converter. We conduct system-level analyses on the overall representation of the HyPoSol system and compare the results with measurements.

INTRODUCTION

In the context of renewable energy penetration, power electronic converters have become increasingly versatile. In the case of microgrids and active distribution networks, jointly operating appropriate components and systems creates new technical challenges to ensure proper components interaction and efficient control of such hybrid power solutions. Given this versatility, modeling hybrid power solutions is key to developing control schemes that are not too specific to a given combination. However, the devices composing the interconnected system may come from many manufacturers, who usually provide only a little information about the internal structure of their products. Generic models exist, but they may lack accuracy, and the specific dynamics associated with those products may not be represented. On the other hand, as a manufacturer of power electronic converters, it may be difficult to provide simulation models to customers without revealing trade secrets.

For those reasons, there is a growing interest in developing black-box models of power electronic converters based on measurements. They are more accurate than generic models as they include dynamics specific to the studied

device. They can be built with few prior information about the studied device, which eases the development of simulation models for system-level analyses. Furthermore, their modular property allows us to combine them with many different models.

In this paper, we propose a model of the HyPoSol system composed of a PV inverter, a battery, and a three-port converter designed by CE+T Power. While we know the in-built control algorithm and topology of the three-port converter, the battery and the PV inverter come from different manufacturers. Since the PV inverter has a certification for grid interaction, generic models might not be able to depict its dynamics adequately as they are too simple. Thus, we use a black-box modeling approach based on measurements. The lithium-ion battery is modelled based on a generalized representation referred to as a Tremblay's model [1]. We then show how the overall representation of the HyPoSol system (Figure 1) can be used to conduct a system-level analysis on a realistic test case involving CE+T Power Sierra three-port converter and Inview controller.

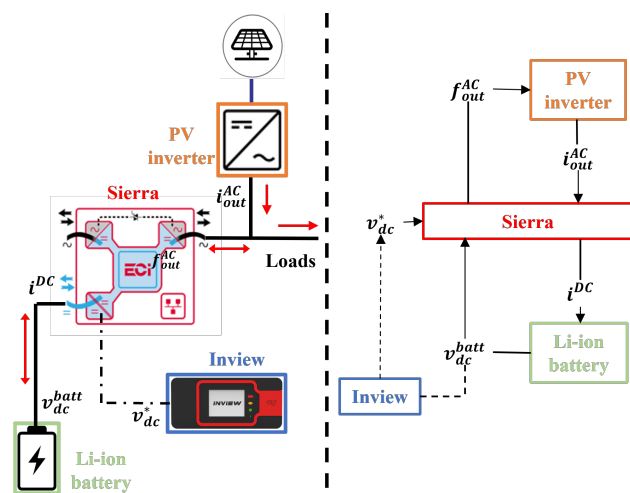

Figure 1: HyPoSol system representation with the physical system on the left and the schematic of the overall model on the right.

CE+T POWER SYSTEM

HyPoSol system

The HyPoSol (for Hybrid Power Solution) system (see Figure 1) is a multi-component system designed to maximize the use of renewable energy. It uses the battery's flexibility and solar production to feed electrical loads. When both sources are insufficient, the system can connect to the electrical grid with the AC-IN port of the three-port converter (Sierra).

The challenge here is to ensure the stable operation of the complete system while each component has its own constraints for continuous operation or stabilizing after a contingency event. The HyPoSol system may be set in many different configurations that can be met at customer sites. Thus, the modeling tool helps to investigate the stability of the different possible configurations without relying on time-consuming and expensive real-world tests.

Sierra converters

Sierra [2] is a three-port converter: an AC input port (AC-IN), an AC output port (AC-OUT), and a DC port. All three ports can be bi-directional. The AC-IN port acts as a grid-following machine (which can be seen as a current source), while the AC-OUT port acts as a grid-forming machine (which can be seen as a voltage source). This allows the converter to impose its voltage and frequency to the AC-OUT port and correctly control the inverter-based generation. In this case, the nominal power, voltage, and frequency of AC-IN and AC-OUT ports are 2400W, 230V, and 50Hz, respectively. The DC port's nominal power and voltage are 2400W and 48V, respectively.

Inview controller

The Inview controller controls [3] the entire system. It ensures communication between all components to avoid power flow mismatch resulting in components failure/damage. One of the tasks of Inview is the control of the DC voltage. This voltage is regulated by the Sierra converters, which receive setpoints from Inview controller. Inview controller changes the DC voltage setpoint based on power flow, security alarms or user orders to charge/discharge or stop the battery. Inview is the interface and controller of the system; in some cases, it could also communicate with other components like a battery, a synchronous generator, or inverter-based generation components to ensure the safe operation of the system. In this case, no communication between Inview and other components (except Sierra) is configured. It means that all other components are driven by physical signals such as voltage or frequency.

PV inverters

Solar inverters are connected to the AC-OUT port of the Sierra converters. However, the principles described in this article can be applied to all inverter-based generators compliant with grid-interactive standards such as AS4777, EN50549 or UL1741SA&SB [4]. By definition, these generators have functionalities such as *freqwatt* and *voltwatt*. These functionalities curtail a given percentage of active power based on the measurement of frequency or voltage, respectively. Therefore, it is possible to set the parameters to speed up or slow down the reaction of the inverter-based generators to a change of frequency. In the following case, PV inverters are compliant with EN50549 standard.

Battery

The battery used in this configuration is a lithium-ion battery. The system can work for different types of batteries. However, some battery suppliers configure their modules with specific protections on the current or voltage. Moreover, some batteries also communicate with Inview and dynamically share the maximum allowed current. In this case, the battery considered is a standard model without specific communication or protection.

MODELLING

Each device shown in Figure 1 is individually modeled and combined with other devices. The system state is updated every millisecond. We detail hereafter the models developed for each system component.

PV inverter

We do not have inside details of the inverter's structure or inbuilt control algorithm. Thus, it has to be modeled by means of blackbox modeling techniques. We are interested in how the inverter's current (i_{out}^{AC}) changes when the AC out frequency (f_{out}^{AC}) changes. The following equation, defined in the *z-domain*, expresses the transfer function relating i_{out}^{AC} with f_{out}^{AC} :

$$i_{out}^{AC}(z) = F(z)f_{out}^{AC}(z), \quad (1)$$

where $F(z)$ is a single input, single output (SISO) system. There is a non-linear dependency between i_{out}^{AC} and f_{out}^{AC} . Indeed, as f_{out}^{AC} rises and passes above 50Hz, i_{out}^{AC} decreases, until it eventually reaches zero. A further increment in f_{out}^{AC} has no impact on i_{out}^{AC} as the current cannot be negative. If f_{out}^{AC} decreases, the current also decreases. If f_{out}^{AC} goes below 50Hz, i_{out}^{AC} does not change. One can use measurements to determine a linear system $G(z)$ as an estimate of $F(z)$: $\hat{F}(z)$. However, $G(z)$ can only be valid in the neighborhood of the operating point at which the measurements were collected. The aim of the CE+T Power system is to control the battery current by modulating the AC-OUT frequency. A local estimation of $F(z)$ is therefore not accurate enough, and one needs to rely on a large-signal model. An

overview of various techniques to derive large-signal models is proposed in [5], where the concept of polytopic models is shown to be a good candidate for black-box modeling of power electronic converters. The procedure described in [6] is based on the concept of polytopic models, but it leverages the universal approximation property of artificial neural networks to mitigate the main drawbacks of traditional polytopic models. We used this procedure to derive a large-signal model of the PV inverter. The idea is to approximate the non-linear system with a sum of weighted linear model responses:

$$\begin{aligned} i_{out}^{AC}(z) &= \sum_{i=1,\dots,N} \omega_i(f_{out}^{AC}(z)) G_i(z) f_{out}^{AC}(z) \\ &= \hat{F}(z) f_{out}^{AC}(z), \end{aligned} \quad (2)$$

with

$$\forall f_{out}^{AC}(z) \in \mathcal{O} \subset \mathcal{R}, \quad \sum_{i=1,\dots,N} \omega_i(f_{out}^{AC}(z)) = 1, \quad (3)$$

ensuring the overall model response is not attenuated nor amplified. $G_i(z)$ corresponds to linear models identified around different operating frequencies $f_{out,i}^{AC}$, N is the number of linear models considered, and \mathcal{O} is the operating space in which we would like the model to be valid ($\mathcal{O} := [f_{out,min}^{AC}, f_{out,max}^{AC}]$). The linear models $G_i(z)$ can be identified using traditional techniques. We first need to create perturbation signals that we apply to the system. In our case, a grid simulator is used to vary the frequency while we measure the inverter's current. We identified five linear models $f_{out}^{AC} = \{47.5, 50, 51.5, 52.5, 53\}$. The weighting function ω_i is represented by a neural network (a multi-layer perceptron), which is trained on a training dataset including the inverter's response over different operating points, and then further tested. Both training and testing datasets consist of the operation of the PV inverter under various operating conditions and are independent of the measurements collected for the identification of linear models. The results on the test dataset are shown in Figure 2.

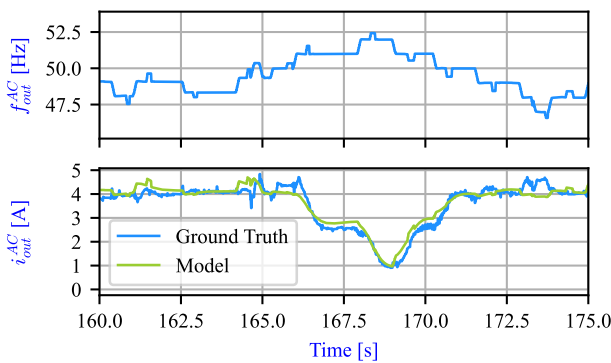

Figure 2: Comparison between PV inverter model ($\hat{F}(z)$) and measurements for different values of f_{out}^{AC} .

Battery

In the CE+T Power system, we have a lithium-ion battery, for which we can use the Tremblay's battery model [1]. The following equations can describe the discharge and charge dynamics:

Discharge

$$v_{dc}^{batt} = E_0 - R i^{DC} - K \frac{Q}{Q - it} (it + i^*) + A \exp(-Bit) \quad (4)$$

Charge

$$v_{dc}^{batt} = E_0 - R i^{DC} - K \frac{Q}{Q - it} (it) - K \frac{Q}{it - 0.1Q} (i^*) + A \exp(-Bit) \quad (5)$$

where v_{dc}^{batt} is the terminal voltage, R the internal resistance, i^{DC} the inrush current, Q the battery capacity, i^* the filtered current, it the discharge capacity and E_0, K, A, B parameters to be identified. We can identify the parameters using different points on the battery discharge curve. The results are shown in Figure 3.

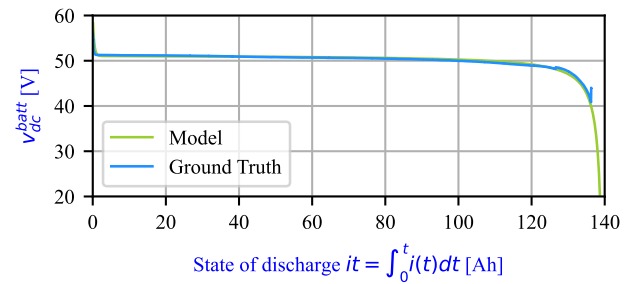

Figure 3: Comparison between the Tremblay's battery model and the actual battery discharge curve.

Sierra converters

The Sierra converters impose an AC-OUT frequency f_{out}^{AC} for reducing the inverter's output current i_{out}^{AC} . We assume that f_{out}^{AC} settles much faster than i_{out}^{AC} , as the Sierra quickly modulates the frequency. Therefore, we can neglect the Sierra dynamics. However, we implement the control algorithm embedded in the Sierra and postulate that once the new frequency setpoint is computed, it is directly applied to the AC-OUT port. The control algorithm has the following form:

$$f_{out}^{AC} = h(v_{dc}^{batt}, v_{dc}^*), \quad (6)$$

where $h(\cdot)$ is the algorithm developed by CE+T Power and v_{dc}^* the voltage setpoint computed by the Inview controller.

The DC current i^{DC} is computed based on the assumption of energy conservation from AC-OUT port to DC port:

$$v_{dc}^{batt} i^{DC} = 3 v_{out}^{AC} i_{out}^{AC}, \quad (7)$$

where v_{out}^{AC} is assumed to be constant and equal to 230V.

Inview Emulator

The Inview control algorithm is emulated thanks to an Inview emulator [7] and sends a command signal (v_{dc}^*) to the Sierra converters. The AC-OUT frequency setpoints are sent every second after receiving the measured battery's terminal voltage. The battery's terminal voltage is updated every millisecond after the system state is computed.

RESULTS

This section aims to identify different HyPoSol system operating conditions and compare model results with measurements collected on the actual system. The results show that the simulation tool can accurately predict the behavior of complex systems. Additionally, the comparisons between real-world tests and simulations enable us to check the accuracy of the modeling. If we find a significant discrepancy between the model results and the measurements, we can easily refine the model thanks to its great modularity. It guarantees its usage for verifying different setups with different sets of parameters.

PV inverters and AC loads are connected to the AC-OUT port in the HyPoSol system. The battery, connected to the DC port, charges if the solar production exceeds the load consumption. The battery can also be discharged to feed the AC loads if the solar output is insufficient. The Sierra modulates the AC-OUT frequency to control the battery charges and discharges. Two control logics exist to control the power going into the battery: one can set a constant current (CC) or a constant voltage (CV). The following results introduce these two controls (CC and CV) and how f_{out}^{AC} is modulated thanks to the Sierra.

Constant voltage mode (CV)

It is possible to set a constant voltage to manage the power entering the battery. The DC voltage at the battery's terminal rises during charging until it reaches the constant voltage setpoint. The Sierra converters modify f_{out}^{AC} to curtail solar production. Since the PV inverters have a certification for grid interaction, their power output reduces if the frequency is higher than 50Hz. To compare the model outcomes with the measurements, Figure 4 displays the frequency and active power entering the battery (P_{batt}) in that particular scenario. It also shows the DC voltage at the battery's terminal.

The DC voltage at the battery terminal equals 51.5V (corresponding to a point in the middle of the curve of Figure 3) when there is no solar production. The DC voltage setpoint is set to 52V. After 200 seconds, the PV panels start producing power that goes into the battery (P_{batt} on Figure 4).

The battery's terminal voltage rises due to the inrush current and exceeds the DC voltage setpoint. The Sierra converter modifies the frequency to reduce solar generation. The initial portion of the frequency curve has a strong slope because the solar output is promptly reduced to lower the DC terminal voltage. After that, the frequency slowly rises to reduce the solar power gradually and to maintain the battery voltage at 52 V.

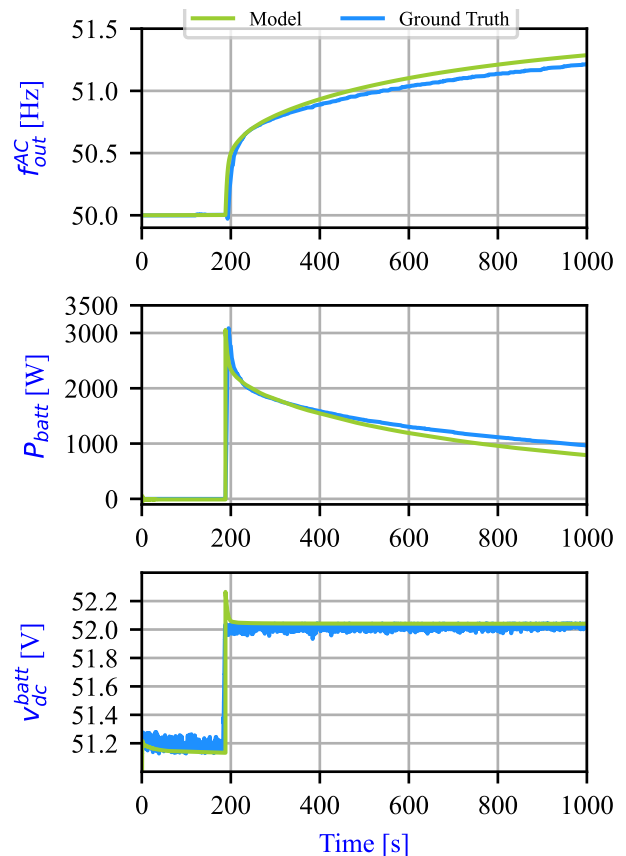

Figure 4: Comparison between HyPoSol model and measurements with a constant voltage setpoint of 52V and maximum active power from PV inverter of 3kW.

The results of Figure 4 show how accurately the model captured the behavior of the actual system. One can see the quick DC voltage rise once the solar inverter is active. This is due to the battery's internal resistance, which causes a voltage rise due to the inrush current. Because of this quick voltage rise, the DC voltage passes above the voltage setpoint imposed by the Inview control algorithm, which forces the Sierra to increase the AC-OUT frequency. In this case, the Inview controller did not play a significant role since the DC voltage setpoint is constant throughout the simulation. In the second case in which we consider a constant current, the Inview controls the system by dynamically adjusting the DC voltage setpoint.

Constant current mode (CC)

In the second test, we set the maximum current to 30A on the DC side (around 1500W); the other parameters are identical to the previous test. The Inview controller computes v_{dc}^* which is applied by the Sierra converters. To take into account the current limit, Inview estimates the battery impedance and compute v_{dc}^* based on this impedance and the maximum current.

The initial increasing ramp of solar production stops when the DC current reaches the limit. Since the current in the battery is controlled by a dynamic DC setpoint computed by the Inview controller, the frequency increases to limit the current flowing to the battery. Due to dynamic changes in the DC voltage setpoint, the f_{out}^{AC} oscillates before reaching an equilibrium. While the frequency oscillates, it induces oscillations in the active power and DC current.

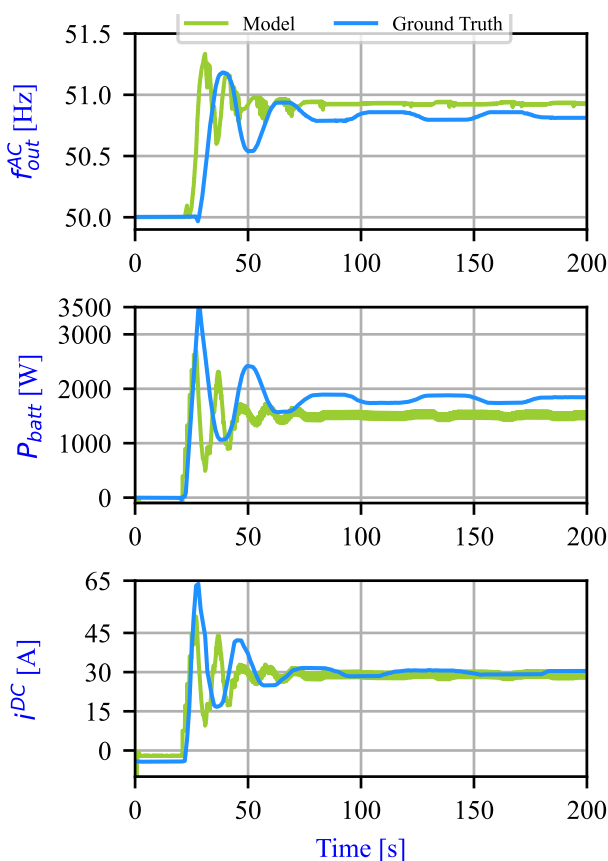

Figure 5: Comparison between HyPoSol model and measurements with a constant current setpoint of 30A and maximum active power from PV inverter of 3kW.

The results of the simulations and measurements on the real system are presented in Figure 5. As can be observed,

the model outcomes predicts the system response but some inaccuracies can be observed during transient. However, the final steady-state value is the same. It is explained by some missing dynamics in the Sierra converters model which should be refined.

CONCLUSION

We have developed a simulation tool to predict the dynamics of a hybrid power system that behaves non-linearly. Our results on the HyPoSol test case show that the simulation tool is accurate and can thus reduce the need for time-consuming and expensive tests on real hybrid power systems. The PV inverter black-box model was identified from measurements and can accurately predict the actual dynamics observed during the system operation. With the great modularity of the black-box models, it is possible to develop simulation tools for more complex systems and, thus, to conduct system-level analyses. Future work will evaluate the approach on more diverse systems and use cases, such as different operating points for the battery.

References

- [1] O. Tremblay and L.-A. Dessaint, "Experimental validation of a battery dynamic model for EV applications," *World Electric Vehicle Journal*, vol. 3, no. 2, pp. 289–298, 2009.
- [2] C. Power, "Description of sierra converter," [Online]. Available: <https://www.cet-power.com/en/product/sierra-10-48-230/>.
- [3] C. Power, "Description of inview controller," [Online]. Available: <https://www.cet-america.com/en/product/inview/>.
- [4] D. Rebollal, M. Carpintero-Rentería, D. Santos-Martín, and M. Chinchilla, "Microgrid and distributed energy resources standards and guidelines review: Grid connection and operation technical requirements," *Energies*, vol. 14, no. 3, p. 523, 2021.
- [5] A. Francés, R. Asensi, Ó. García, R. Prieto, and J. Uceda, "Modeling electronic power converters in smart DC microgrids—an overview," *IEEE Transactions on Smart Grid*, vol. 9, no. 6, pp. 6274–6287, 2017.
- [6] A. Colot, A. Giannitrapani, S. Paoletti, and B. Cornélusse, "Enhanced neural network-based polytopic model for large-signal black-box modeling of power electronic converters," Manuscript submitted for publication, 2023.
- [7] C. Power, "Emulator of inview controller, online access," [Online]. Available: <https://www.cet-power.com/fr/emulateur-de-monitoring/>.