

# High resolution compact vertical inertial sensor for atomic quantum gravimeter hybridizing

Anthony Amorosi, Amez-Droz Loïc, Christophe Collette (supervisor)

2nd year PhD at ULiège & ULB (Belgium)

November 18, 2022

# Quantum gravimeter

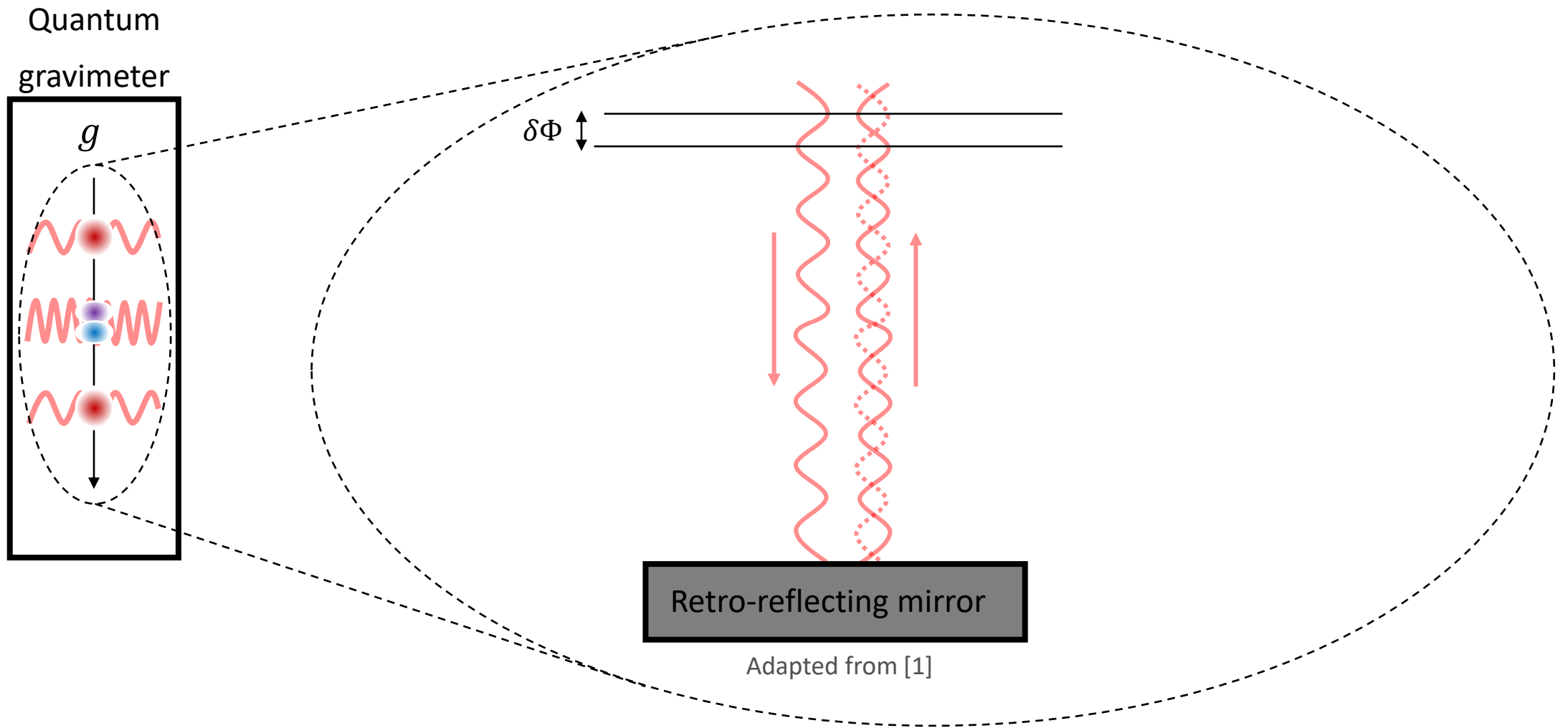

# Quantum gravimeter

Quantum gravimeter

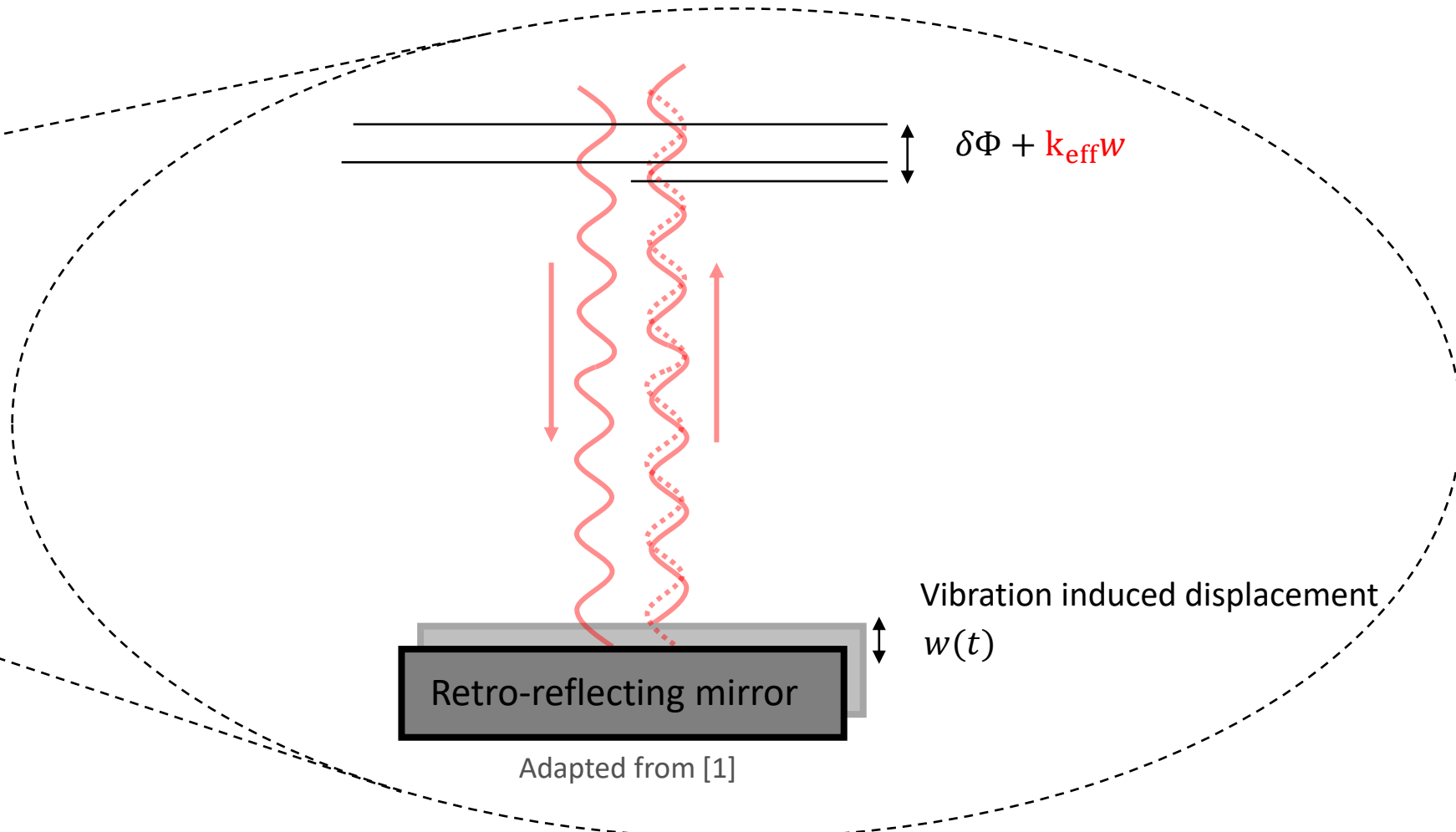
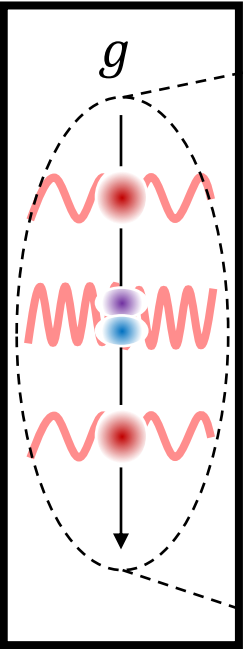

Retro-reflecting mirror

Adapted from [1]

# Vibration compensation techniques

Passive vibration isolation

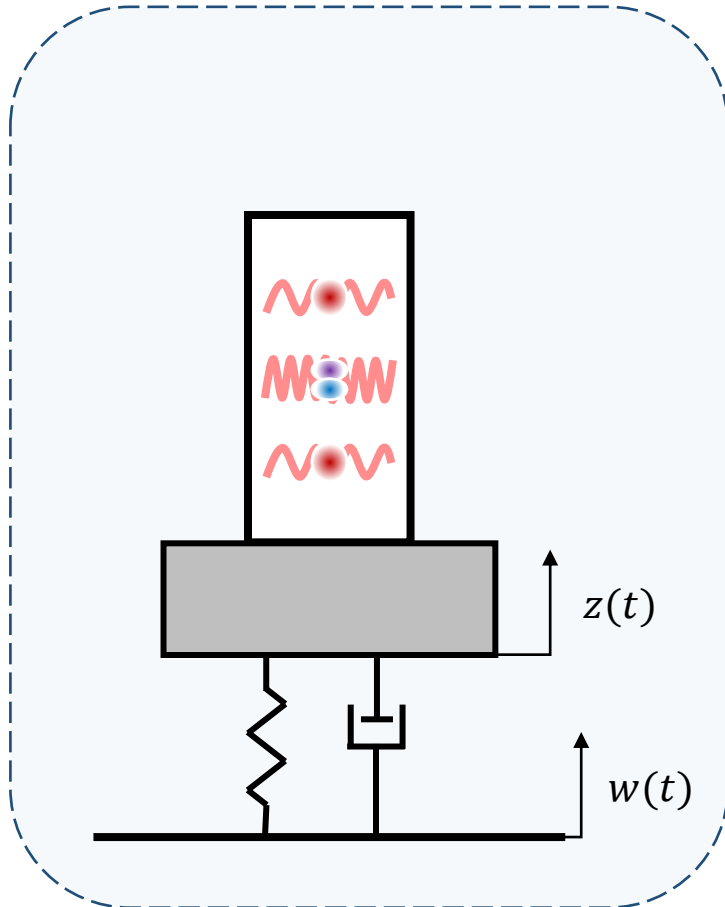

Active vibration isolation

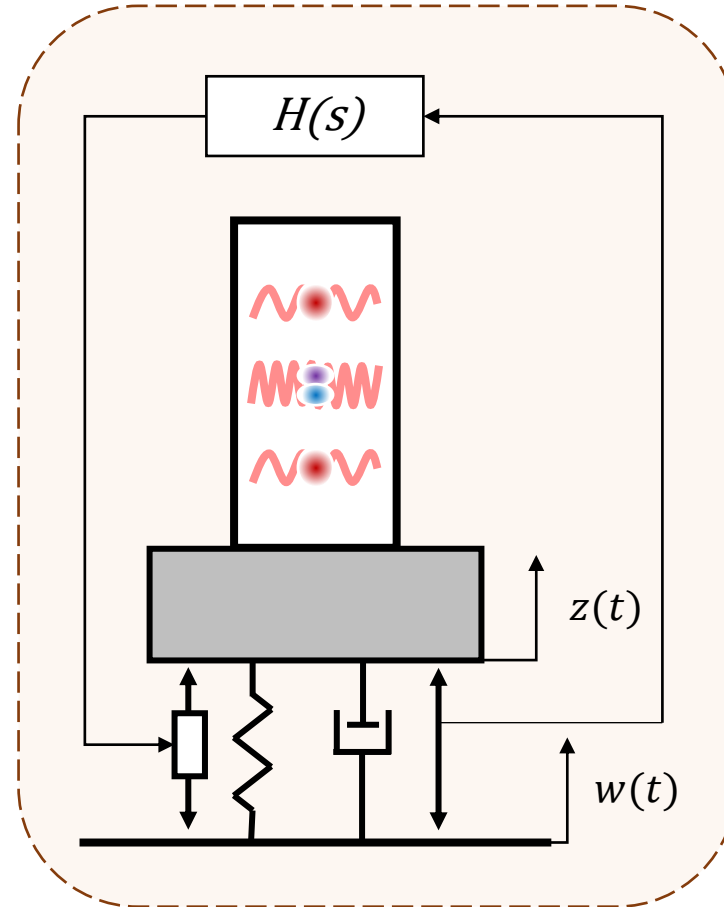

Software rejection

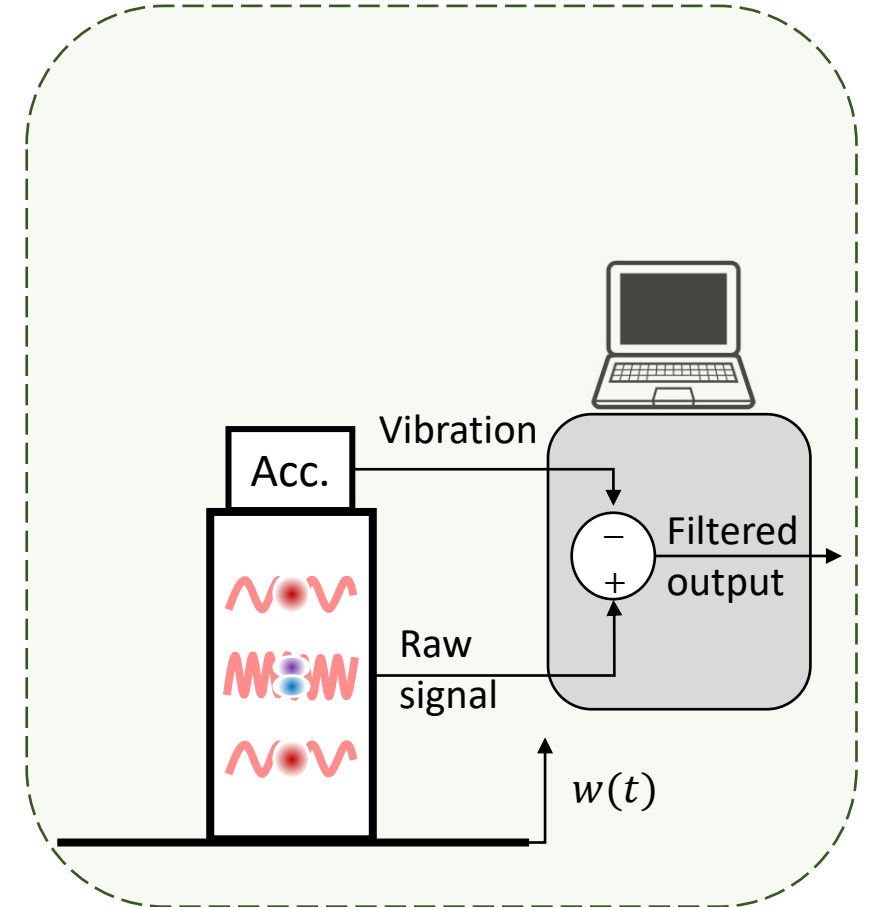

# Vibration compensation techniques

Passive vibration isolation

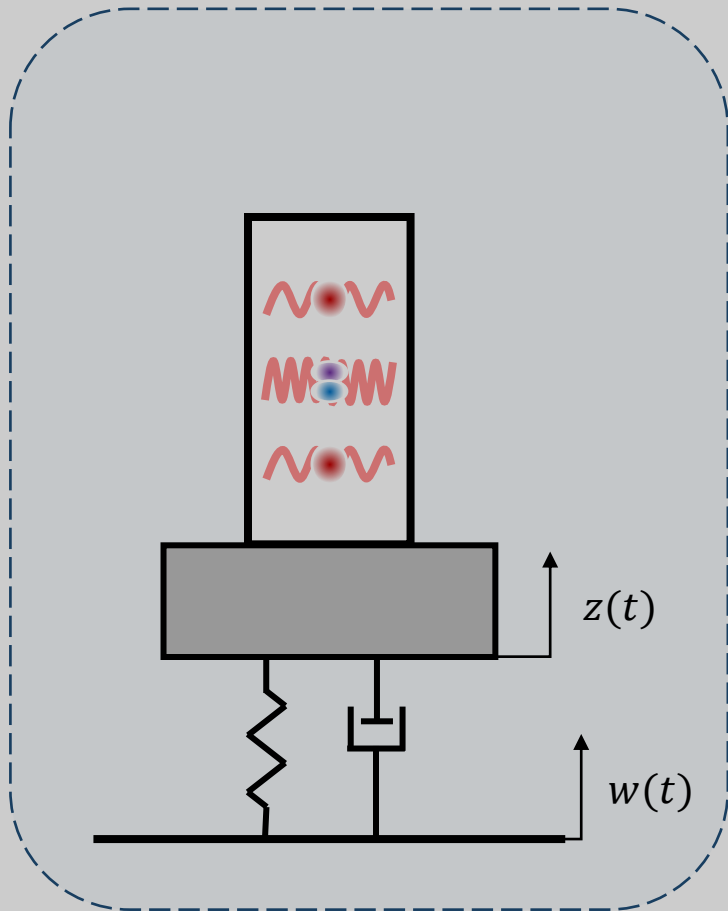

Active vibration isolation

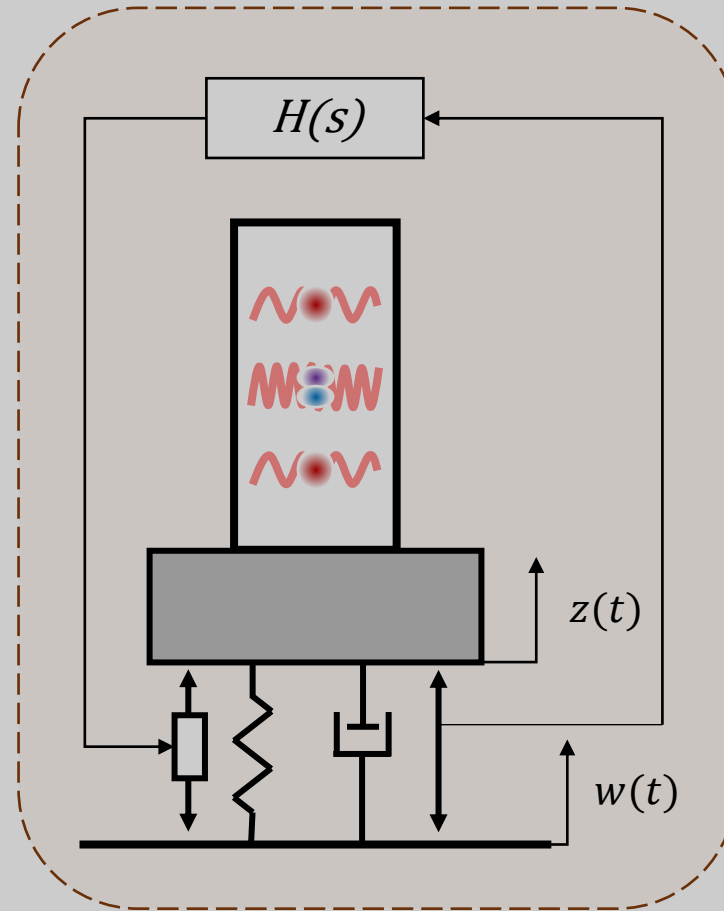

Software rejection

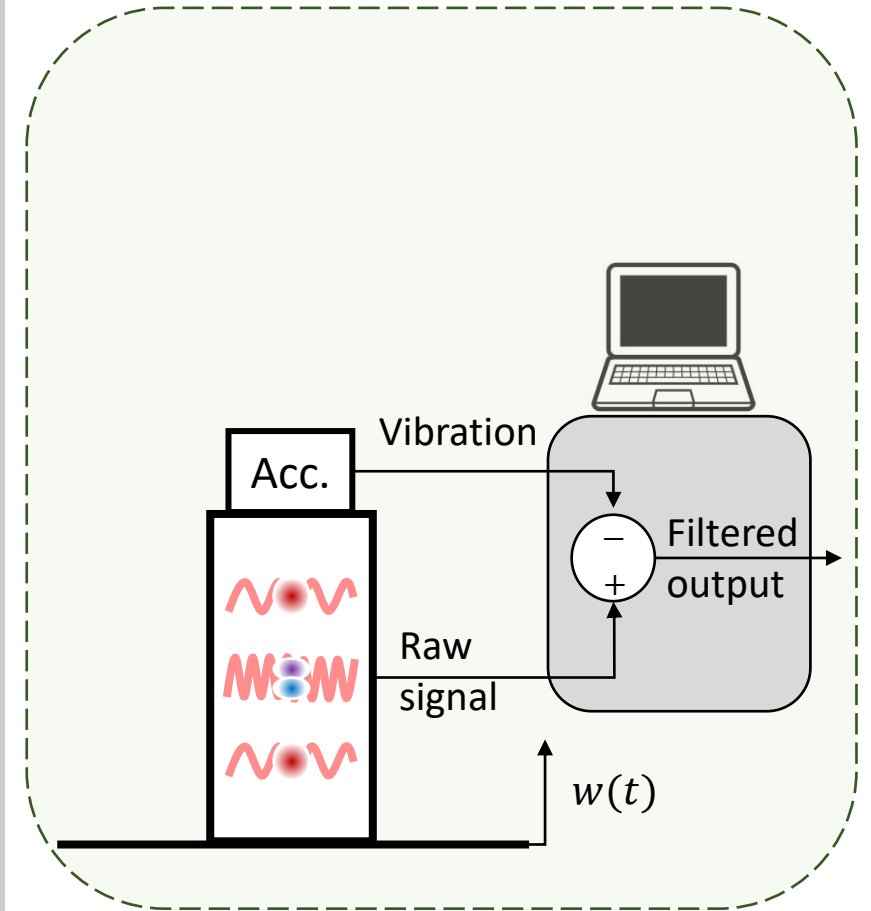

# Outline

---

- Gravimeters and effects of ground vibrations
- Compact Vertical INterferometric Sensor ( $\mu$ VINS)
- Conclusion and future work

# Vertical inertial sensor

Low stiffness mechanics and guidance

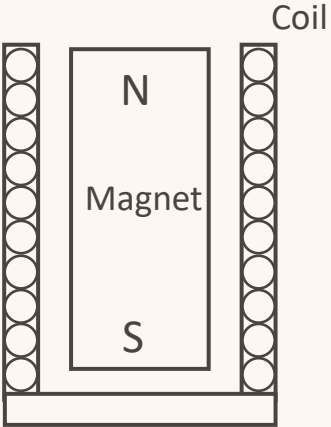
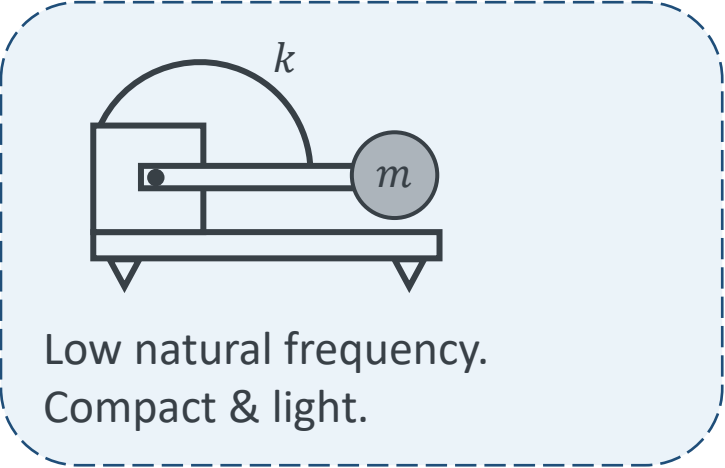

Low noise injection.  
Improved linearity and bandwidth.

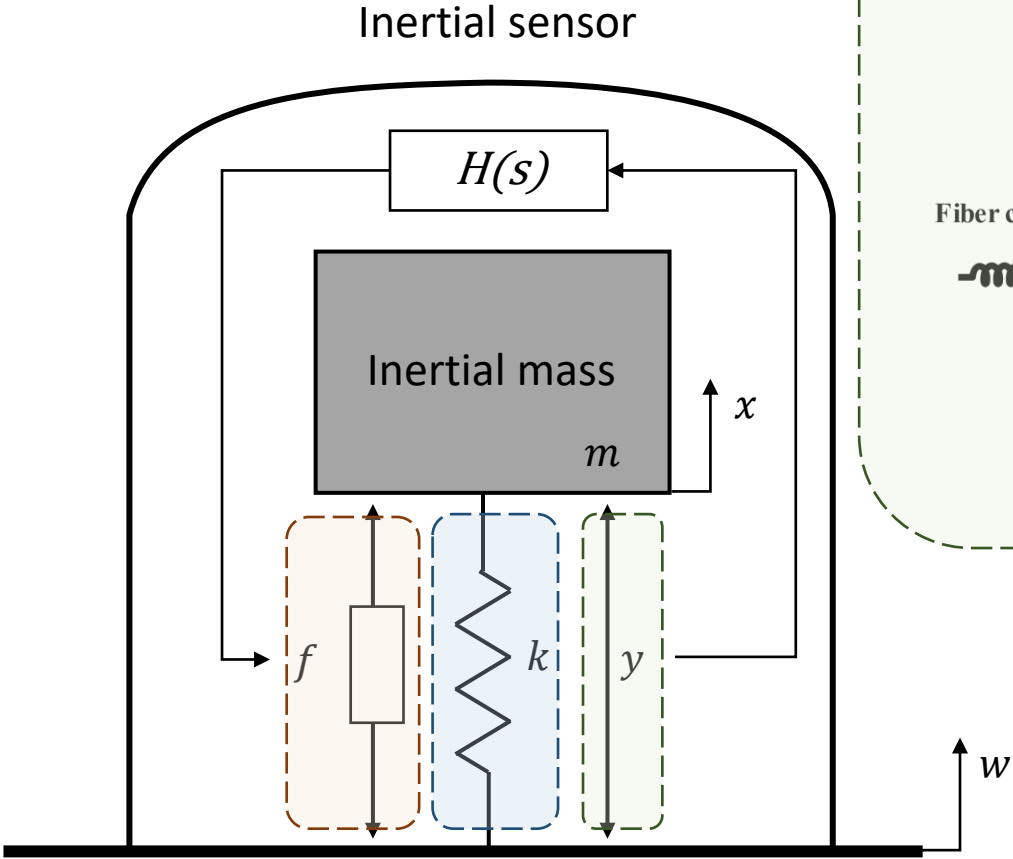

Contactless actuation

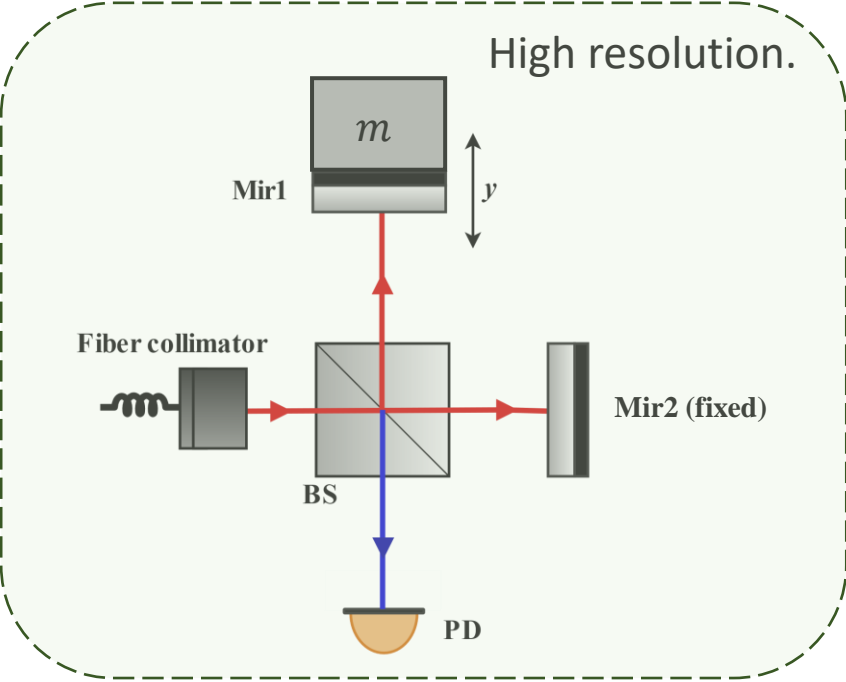

Contactless readout

# $\mu$ - Vertical INterferometric inertial Sensor

Low stiffness mechanics and guidance

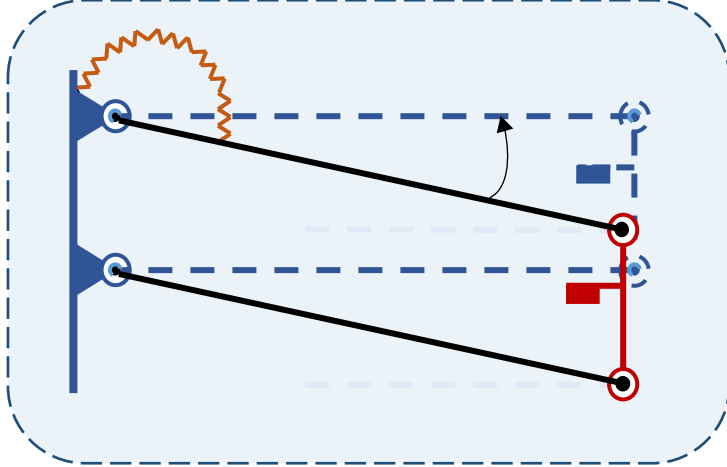

$\mu$ VINS

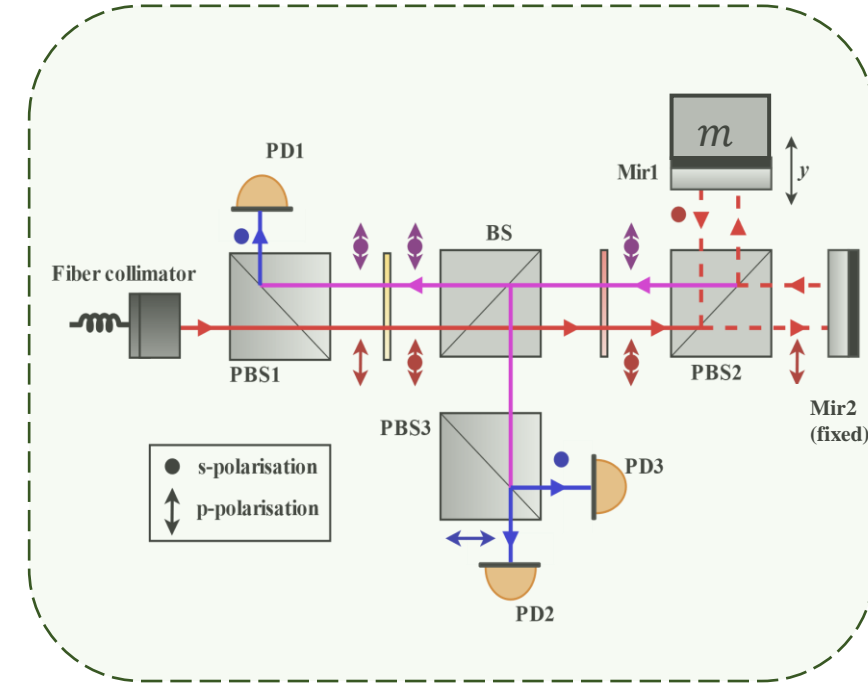
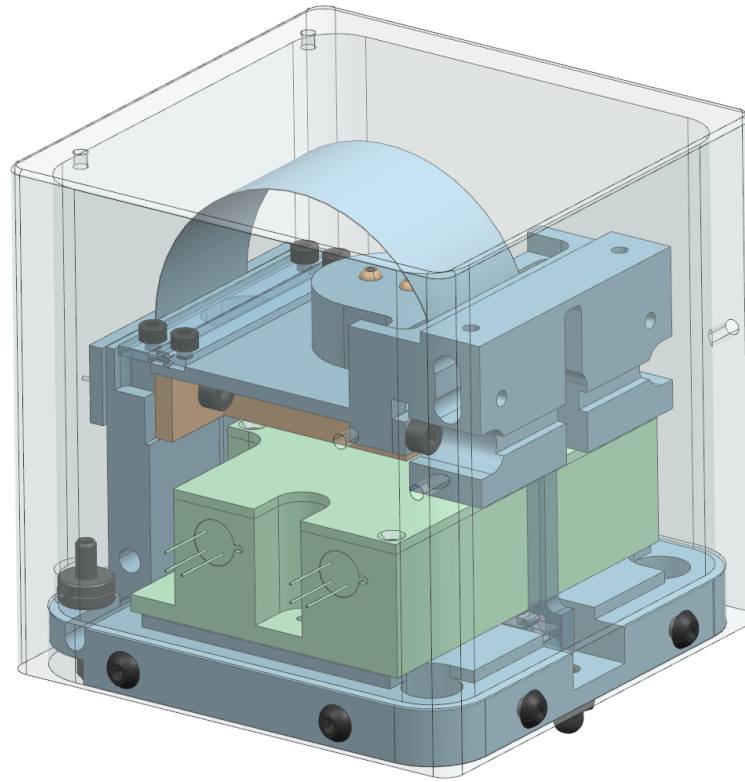

Contactless readout

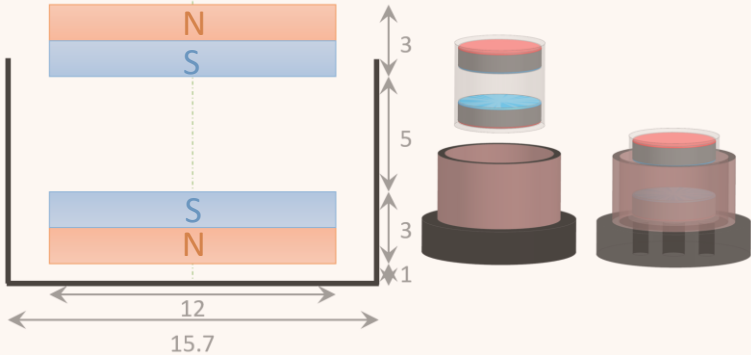

Contactless actuation



# Low stiffness mechanical guide

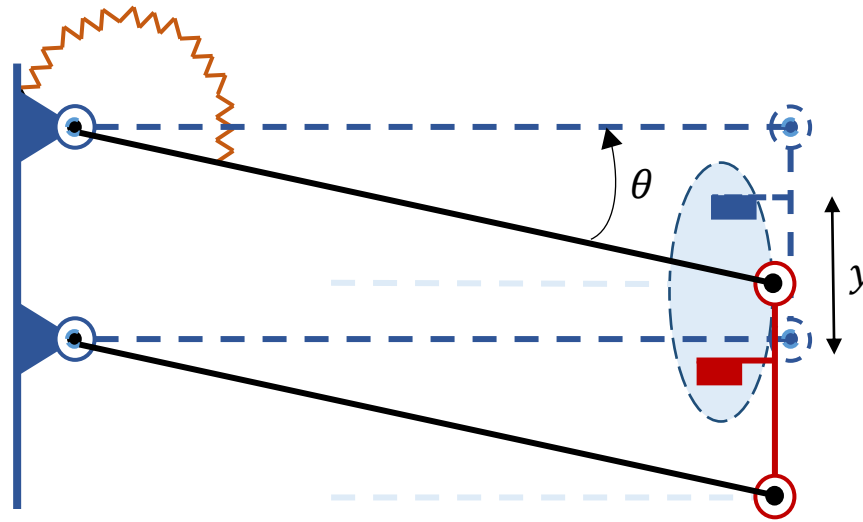
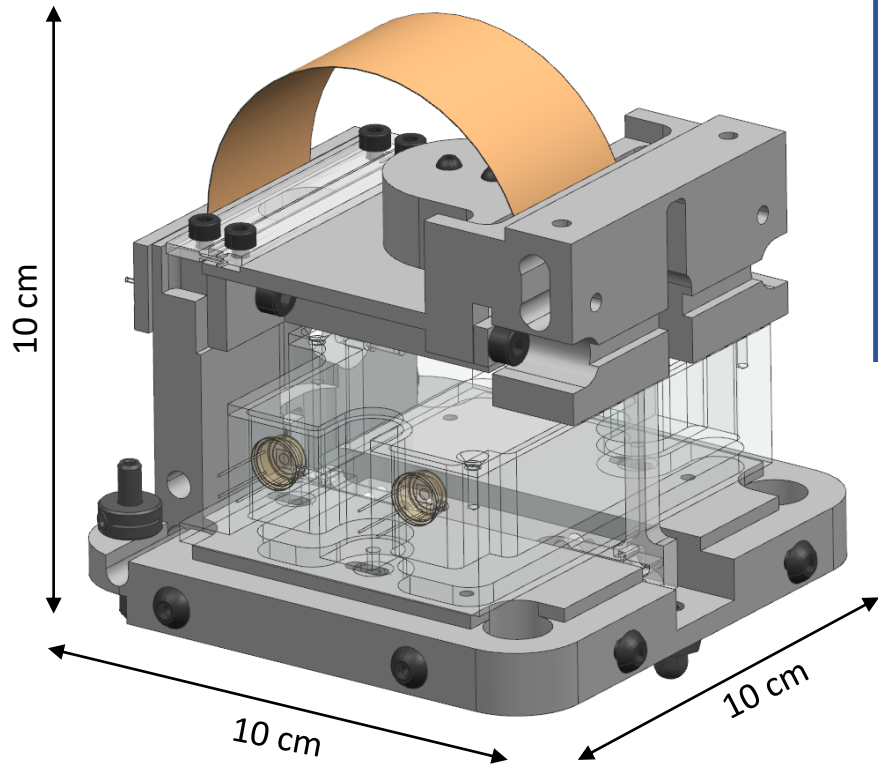

Linear, angle-maintaining,  
motion of the mirror.

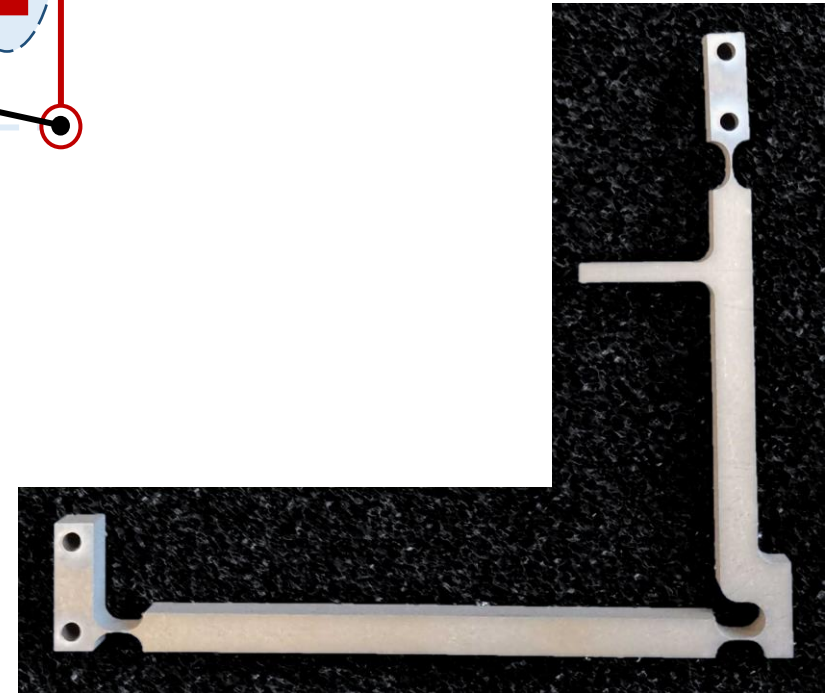

# Low stiffness mechanical guide

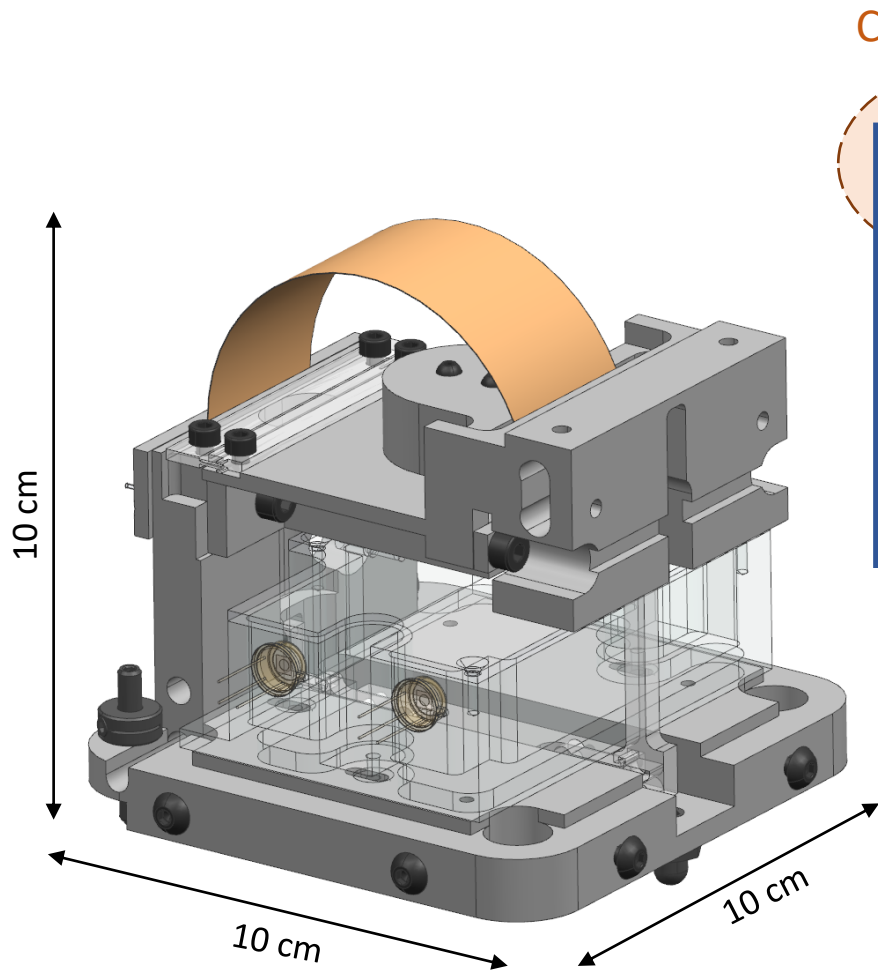

CuBe leaf-spring

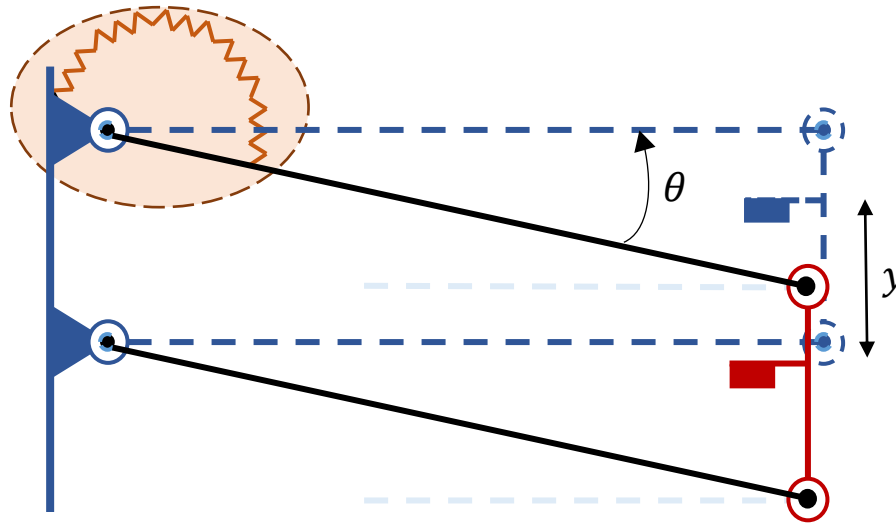

2.8 Hz natural frequency suspension.

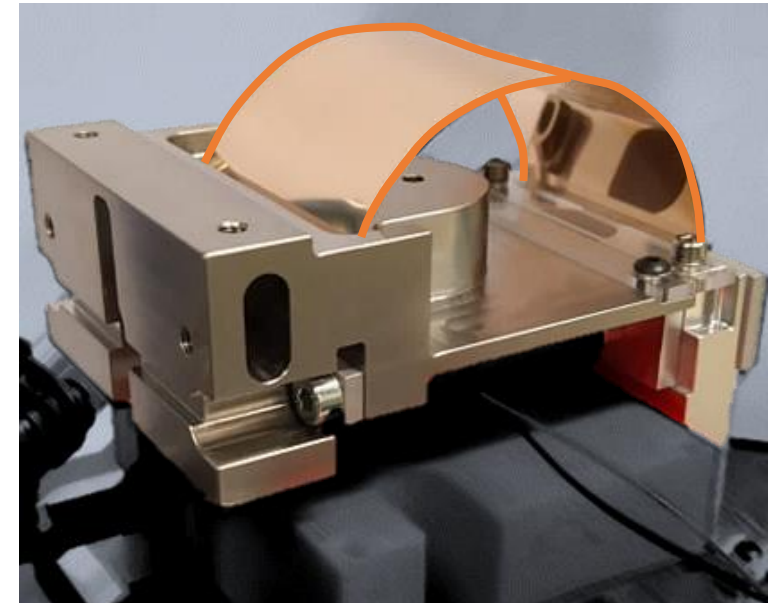

# Low stiffness mechanical guide

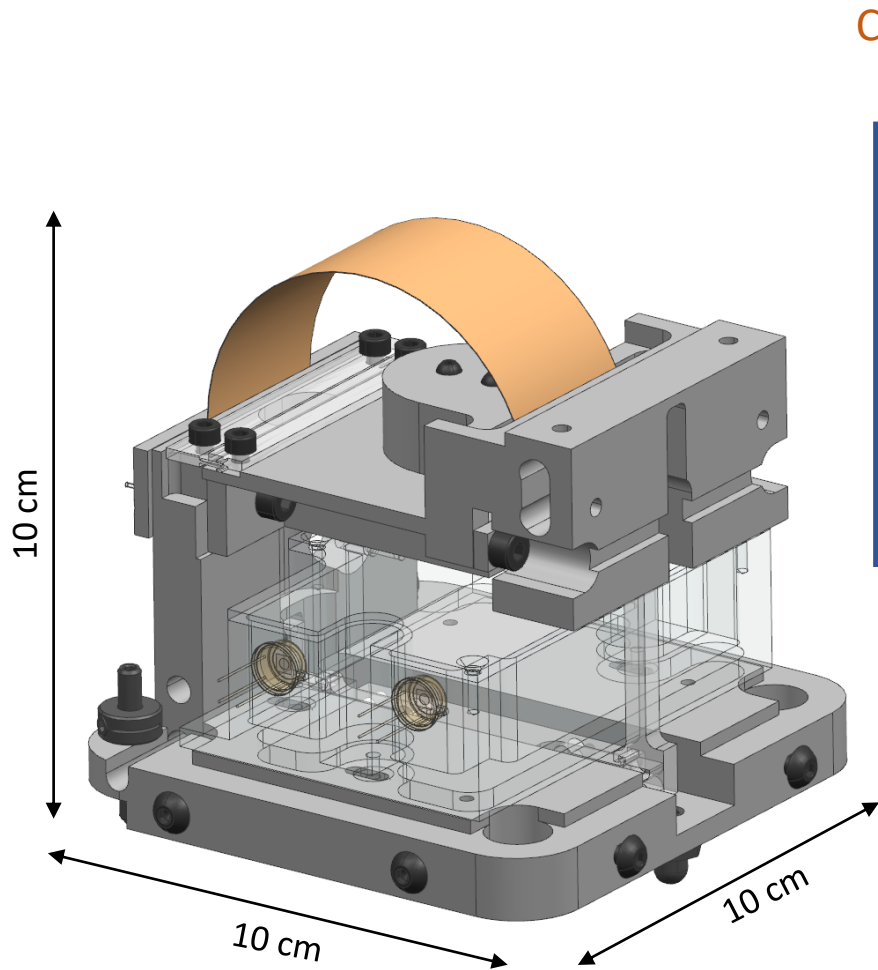

CuBe leaf-spring

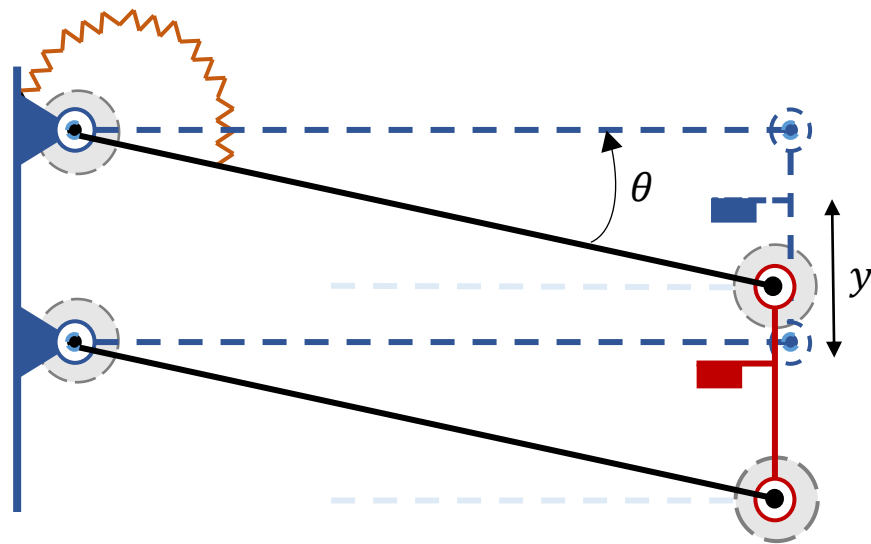

Low dissipation fused-silica joints.

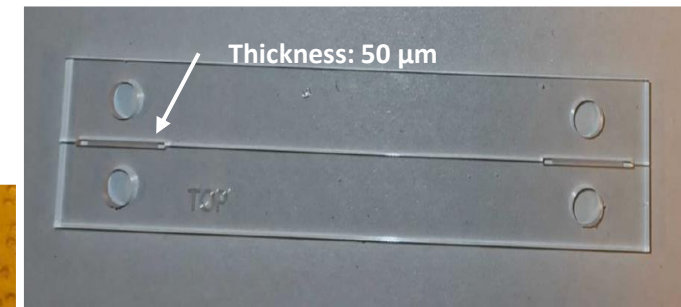
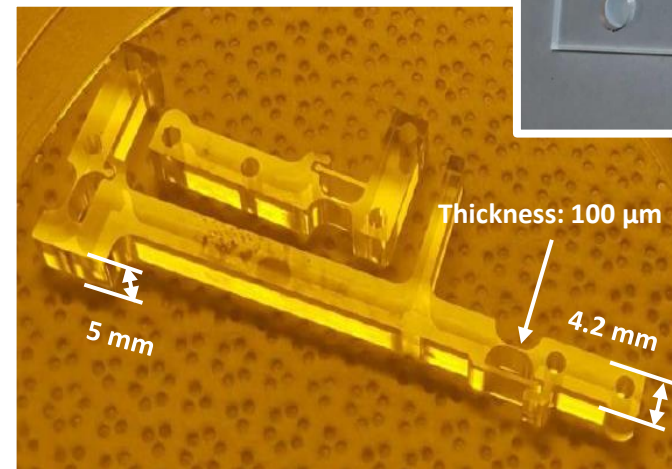

# Interferometric readout

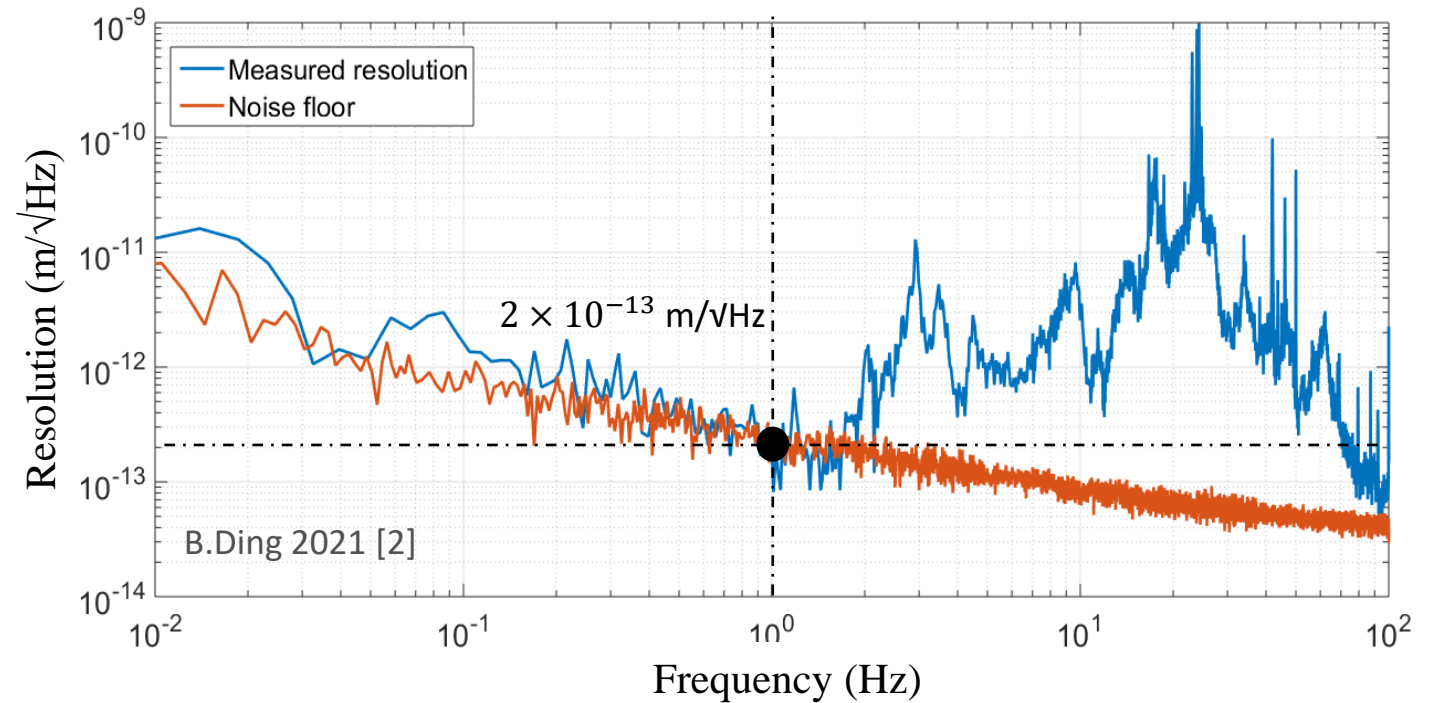
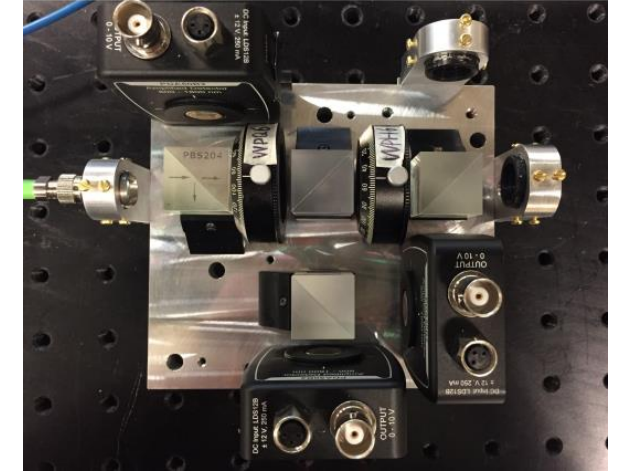
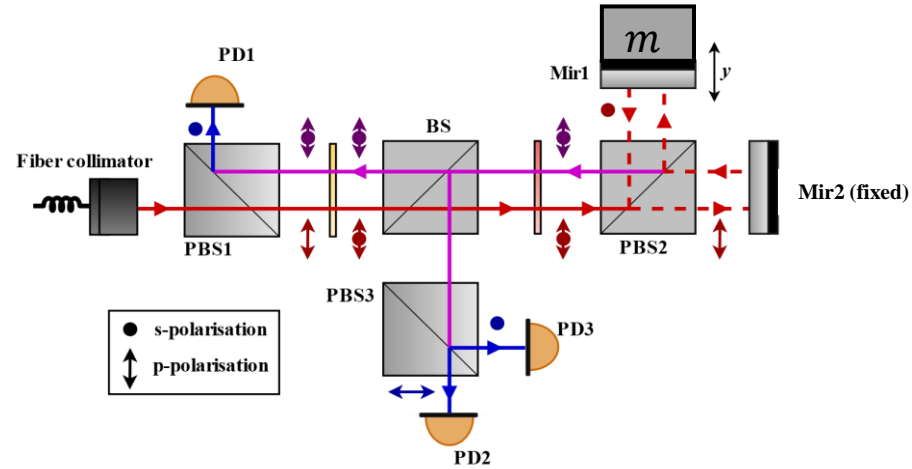
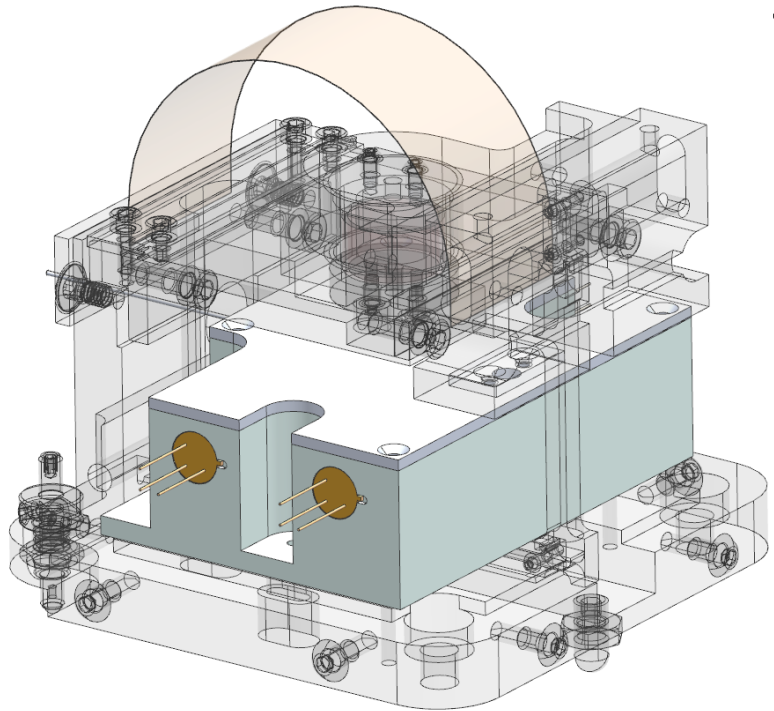

# Quadrupole voice-coil actuator

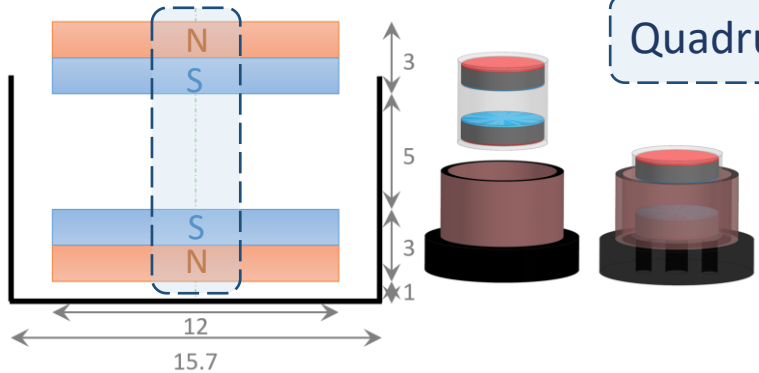
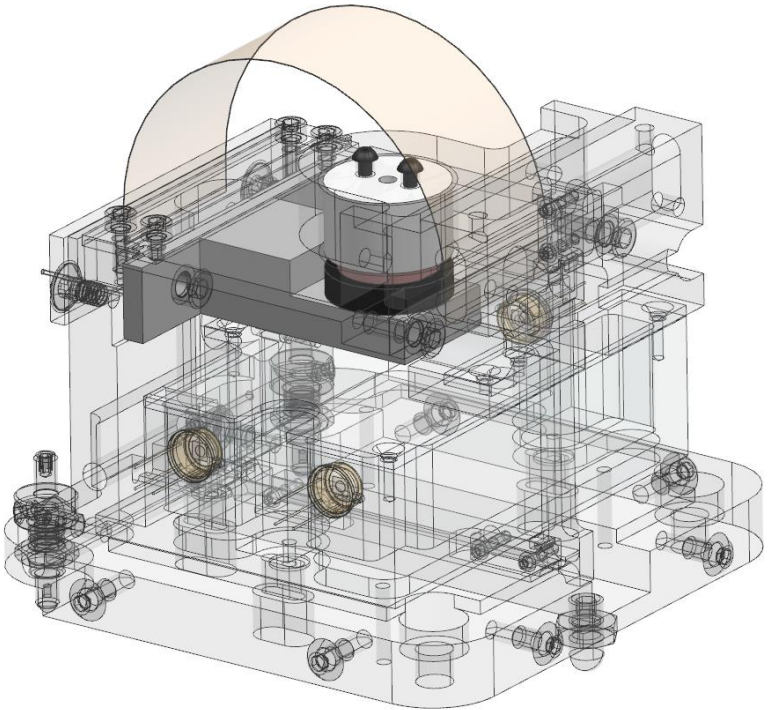

Quadrupole, selfshielded, magnet.

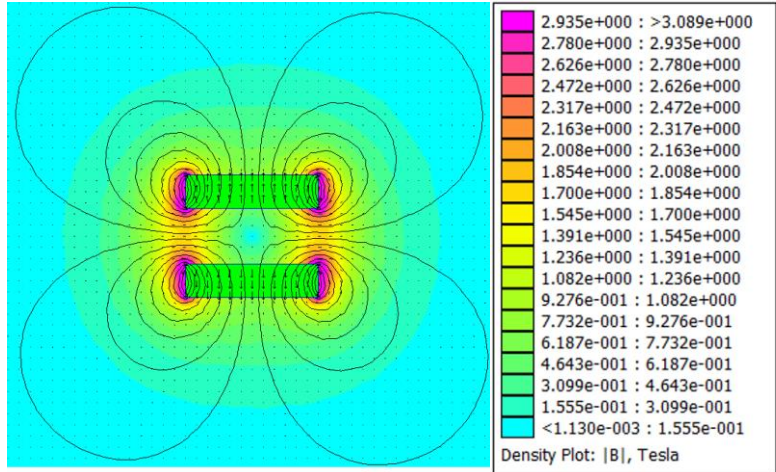
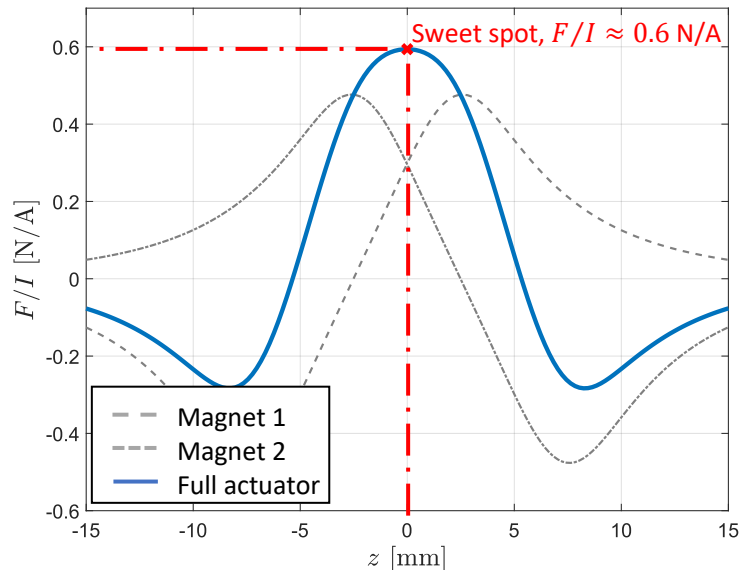

Numerical optimization of the geometry.

# Noise budgeting

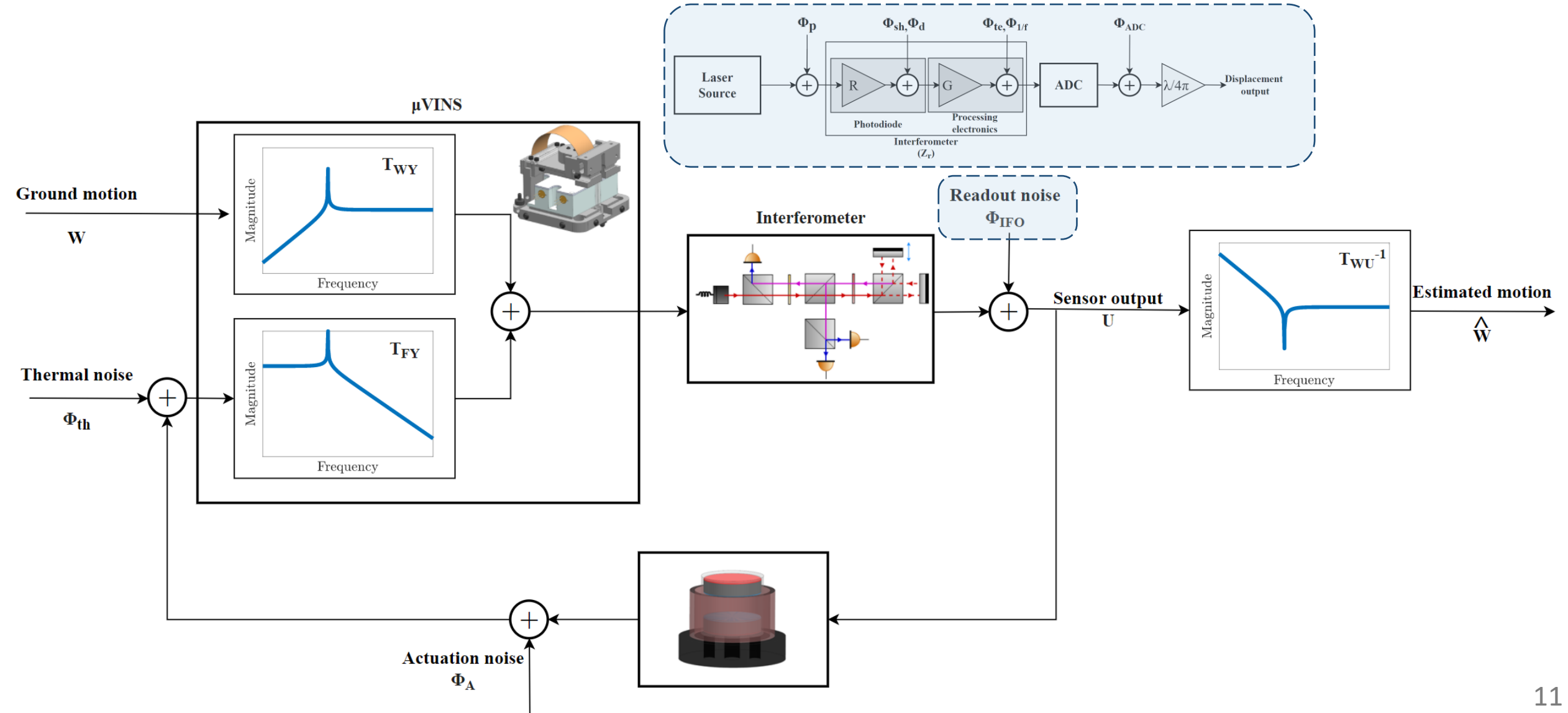

# Noise budget

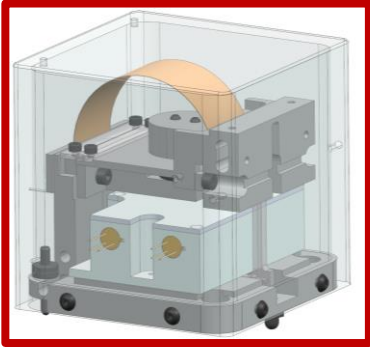

$\mu$ VINS

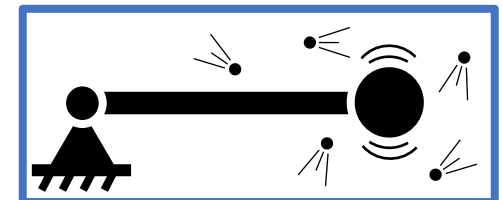
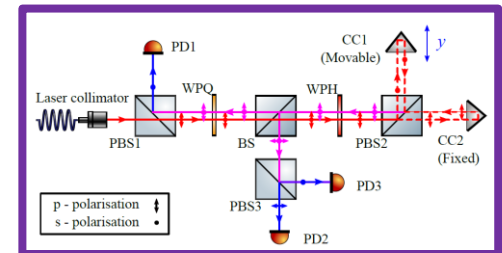
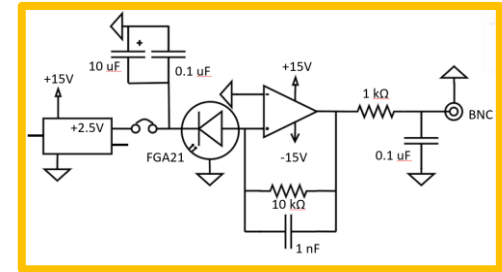
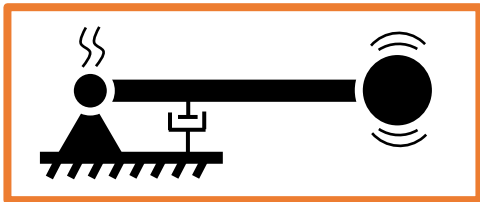
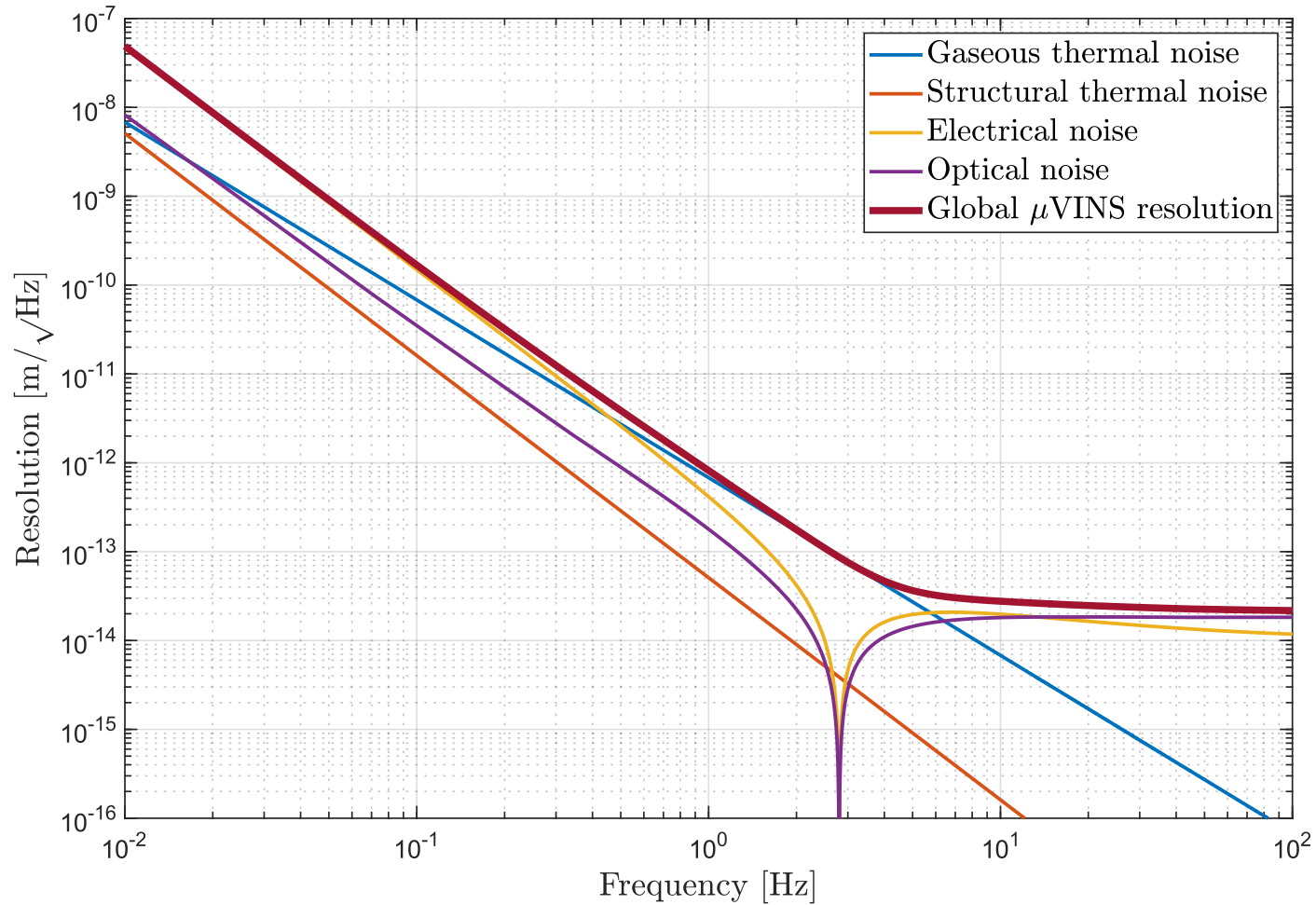

# Noise budget

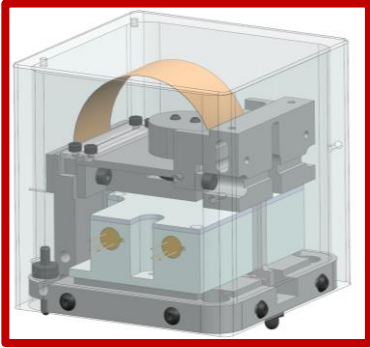

μVINS



Trillium



Titan

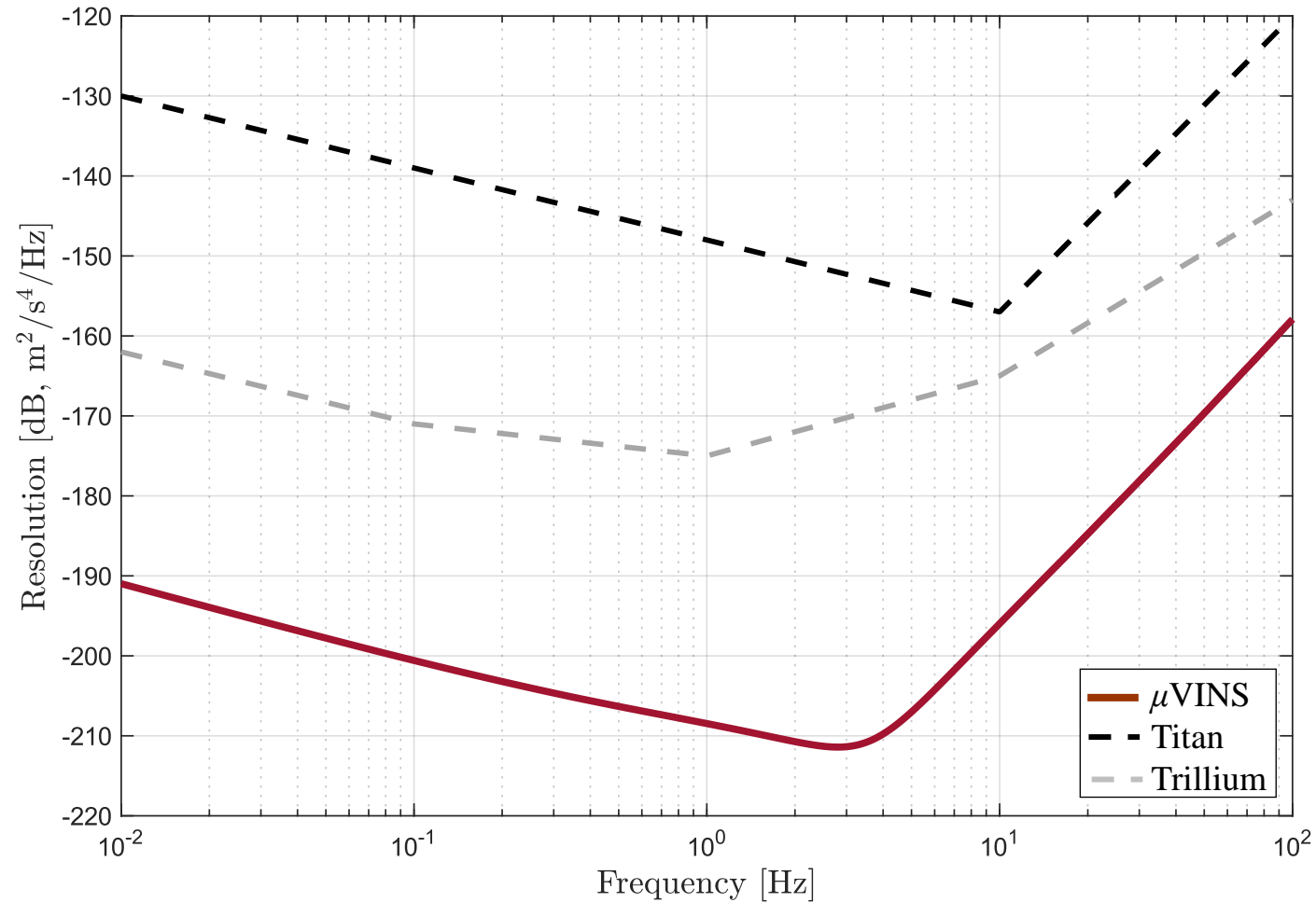



# Outline

---

- Gravimeters and effects of ground vibrations
- Compact Vertical INterferometric Sensor ( $\mu$ VINS)
- Conclusion and future work

# $\mu$ VINS testing campaign

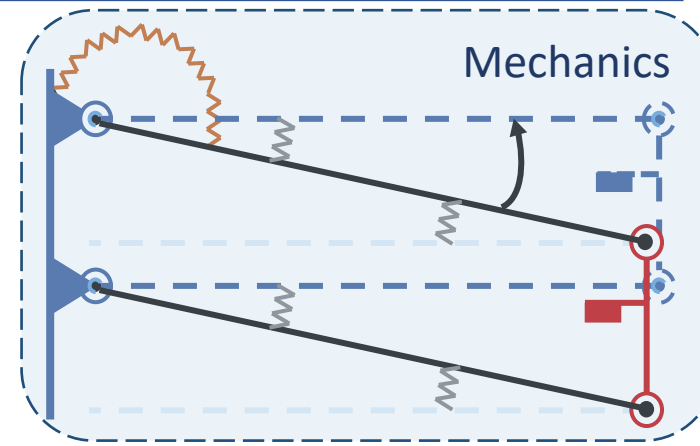
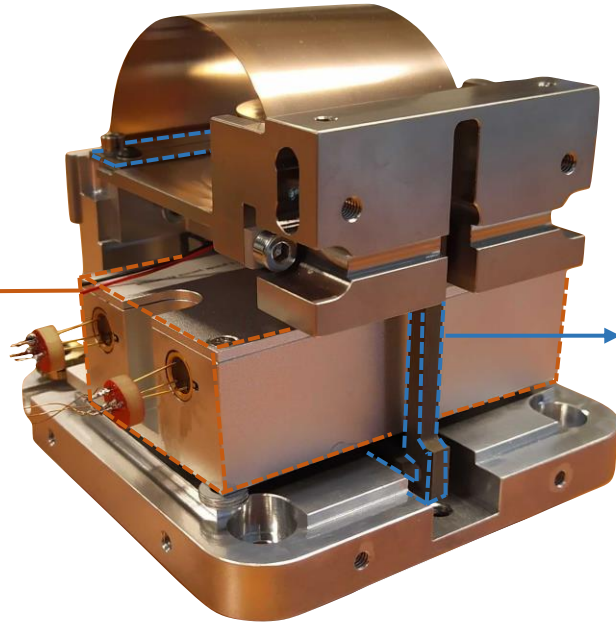

## Quadrature optical readout

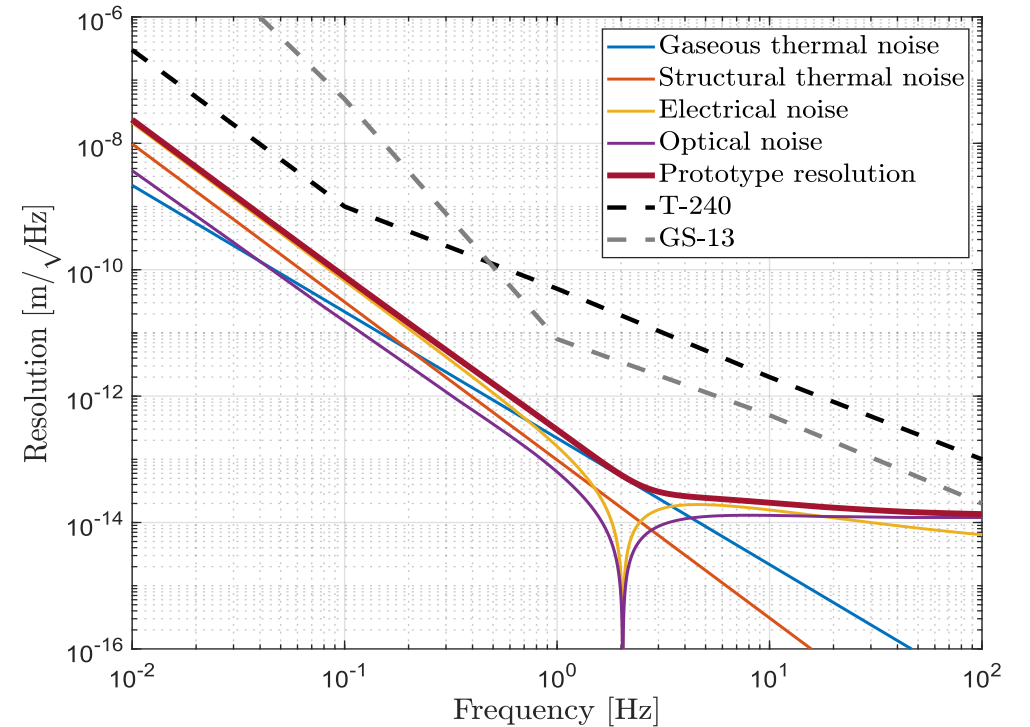
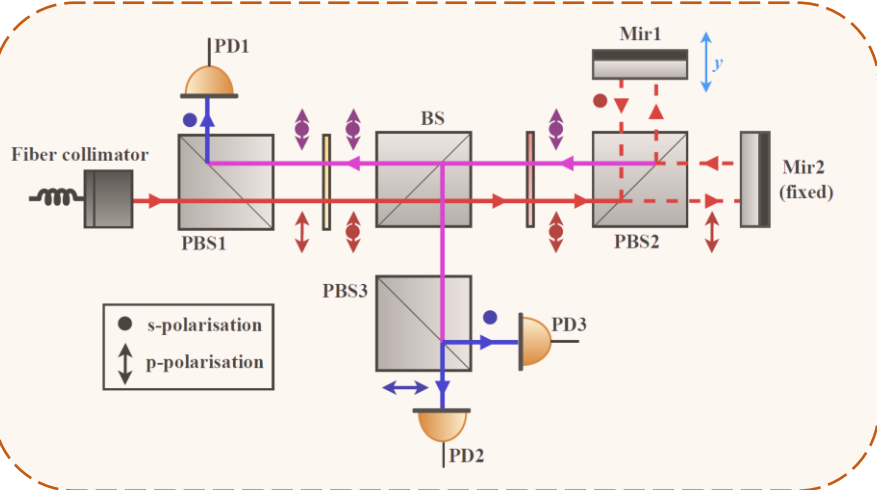

# Vibration compensation

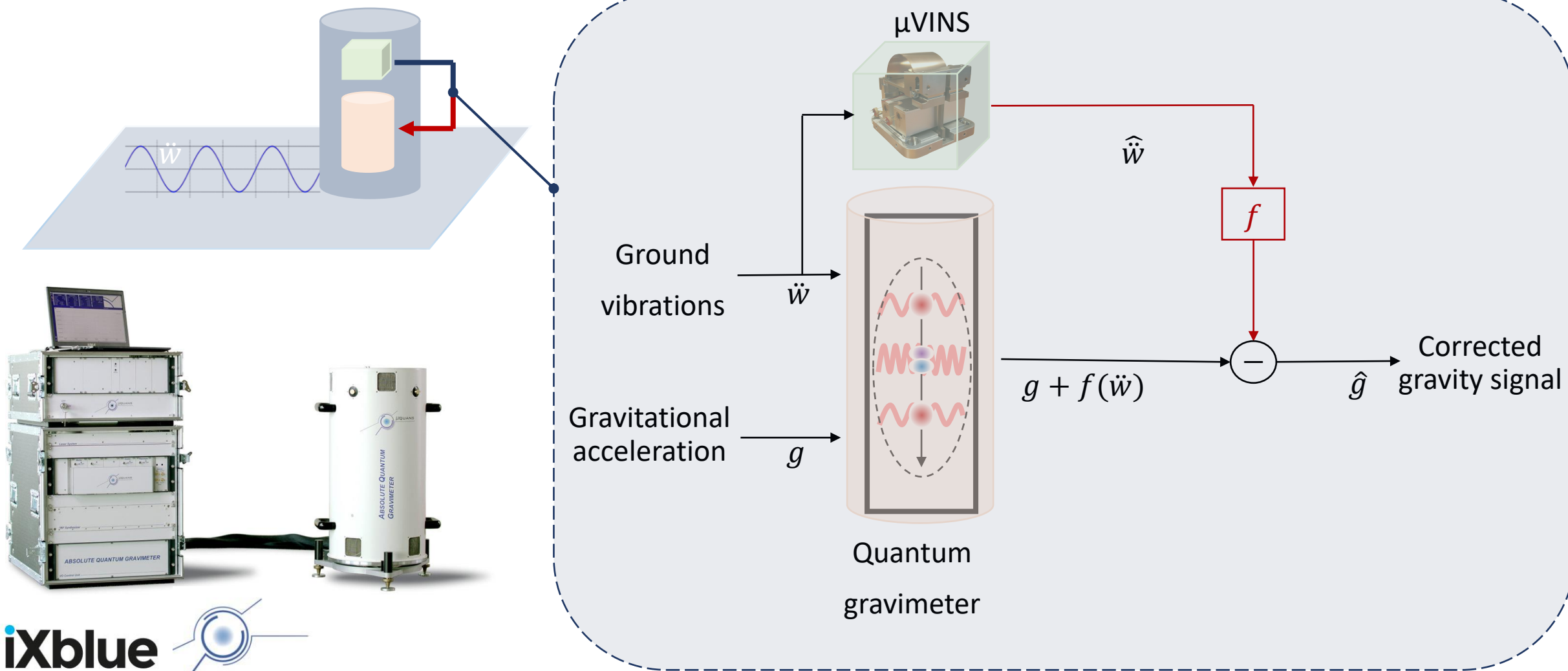

# Full hybridizing

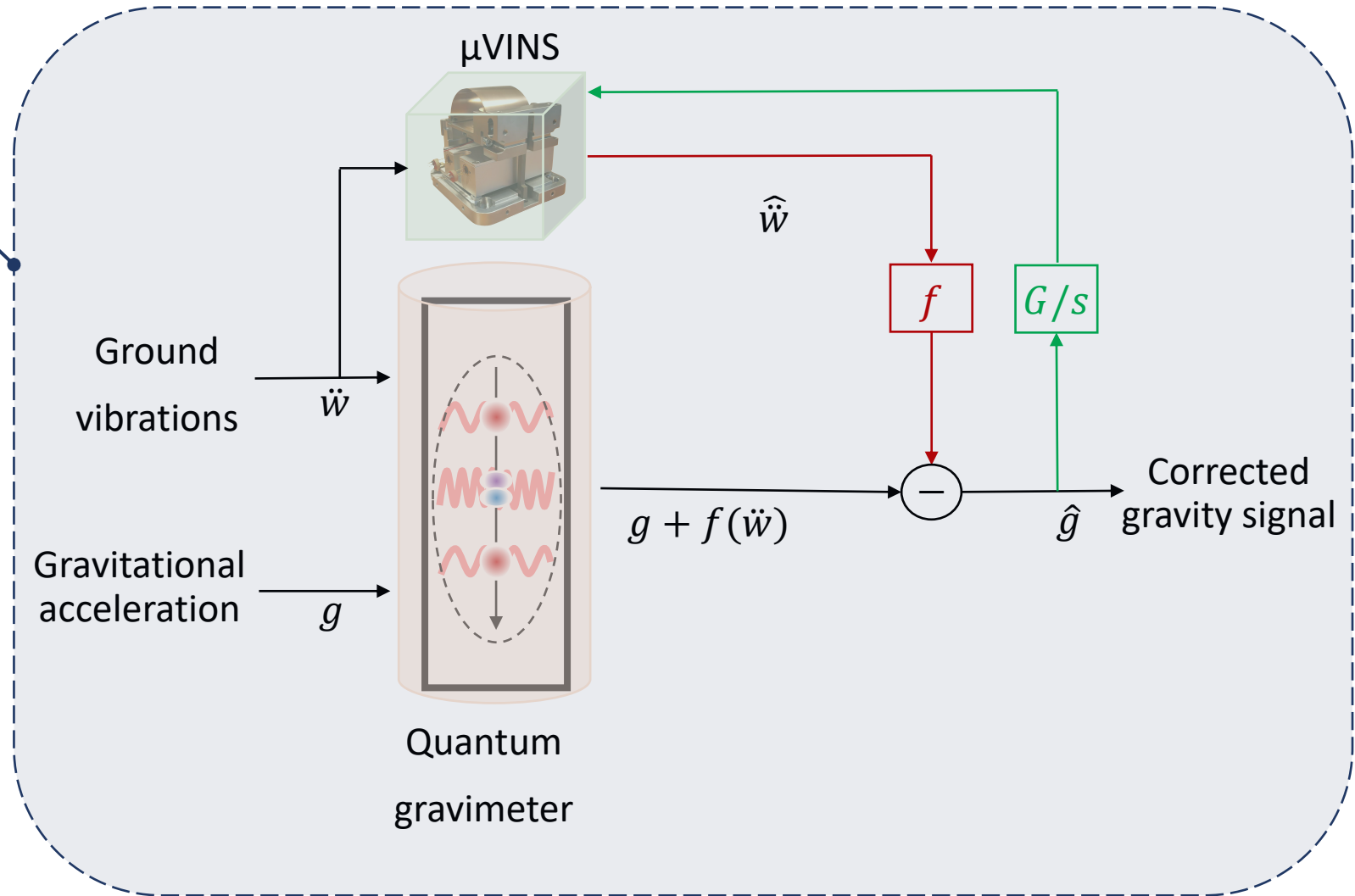
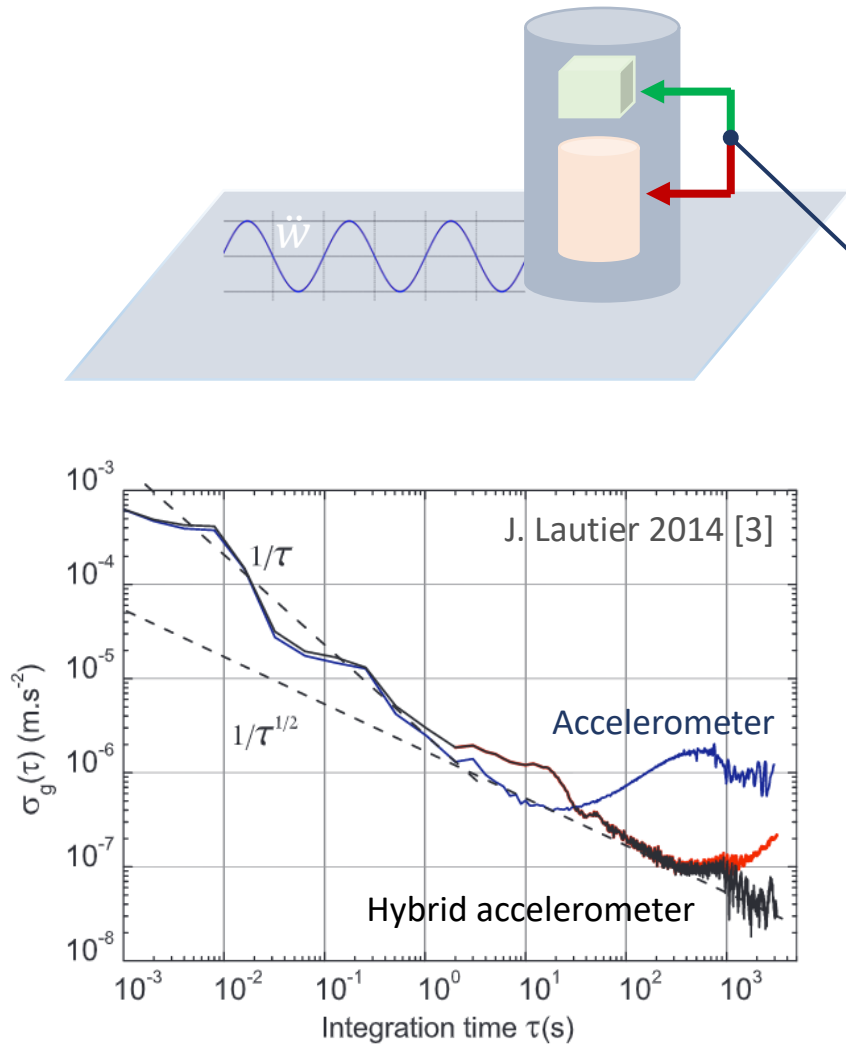

# Vibration compensation techniques

Passive vibration isolation

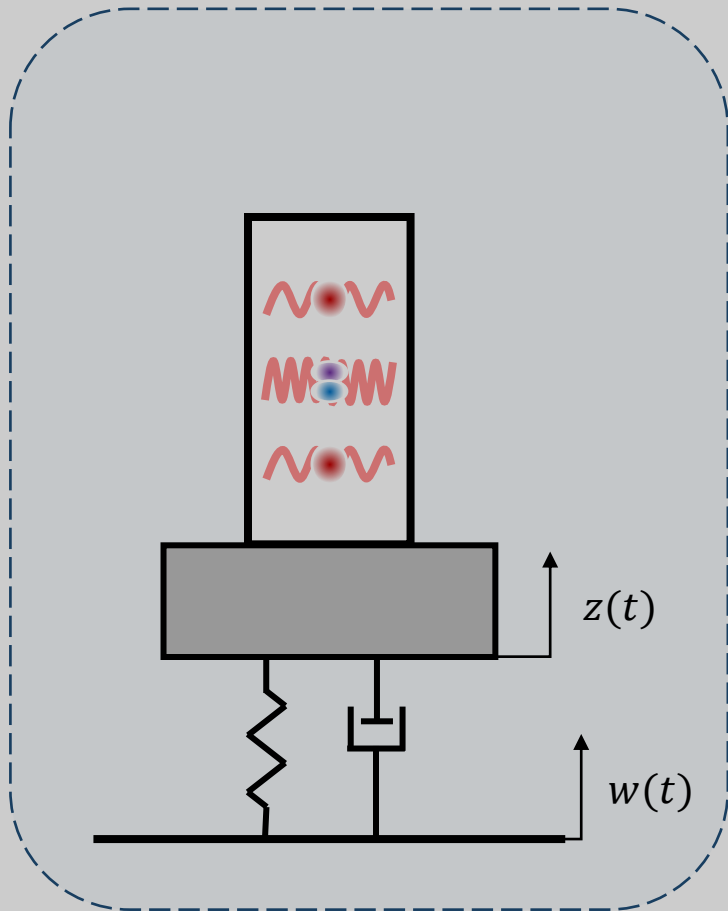

Active vibration isolation

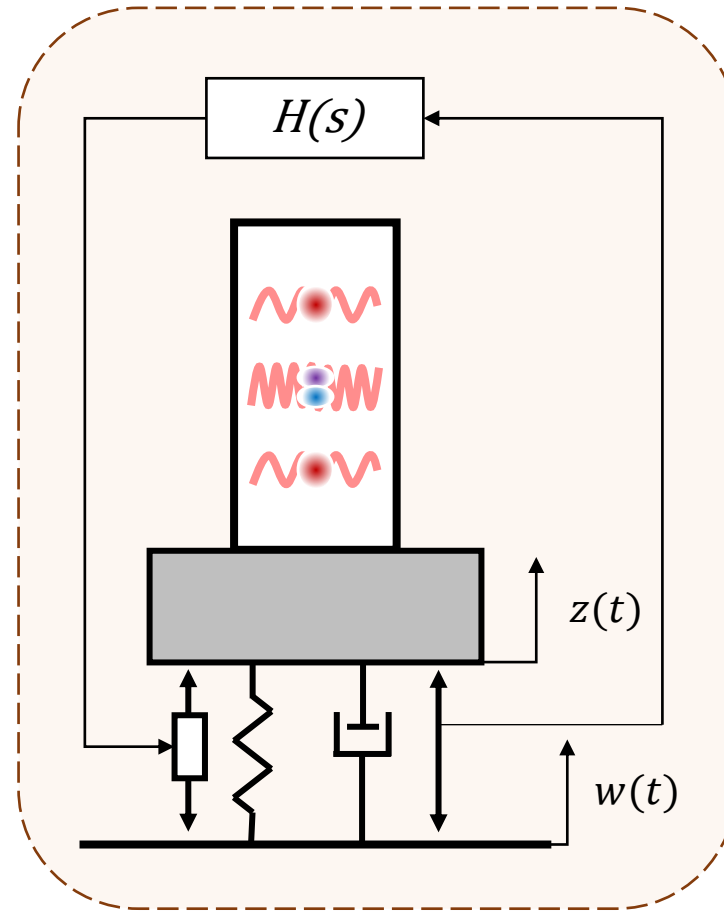

Software rejection

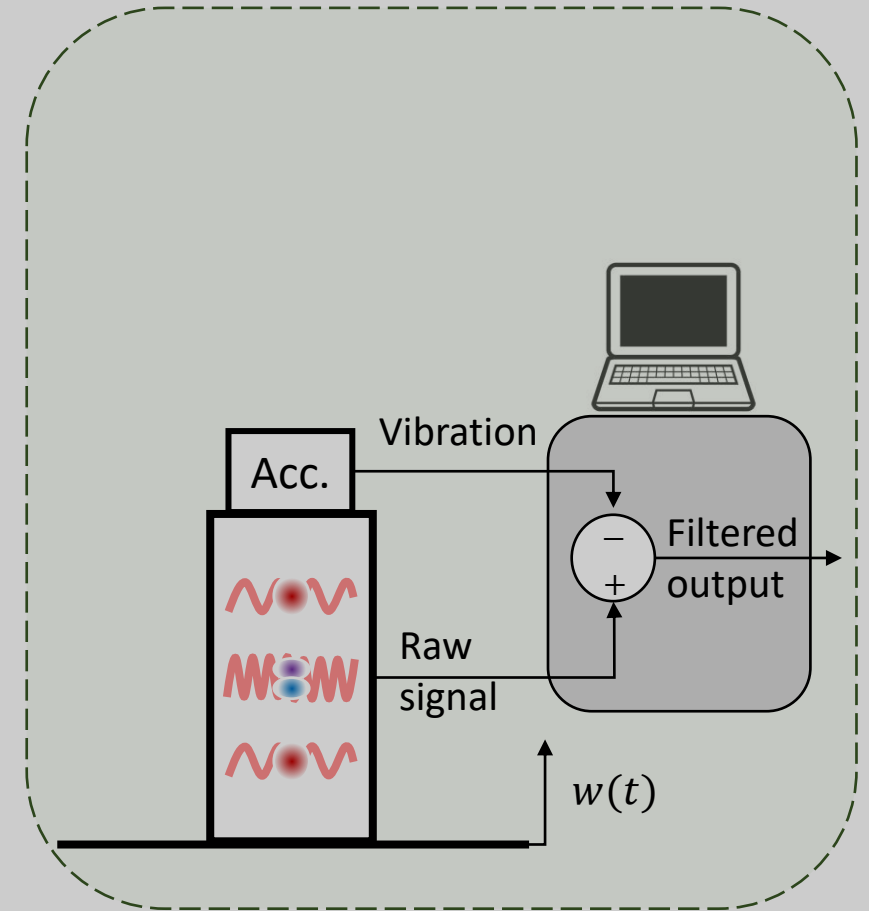

# Active isolation of a quantum gravimeter

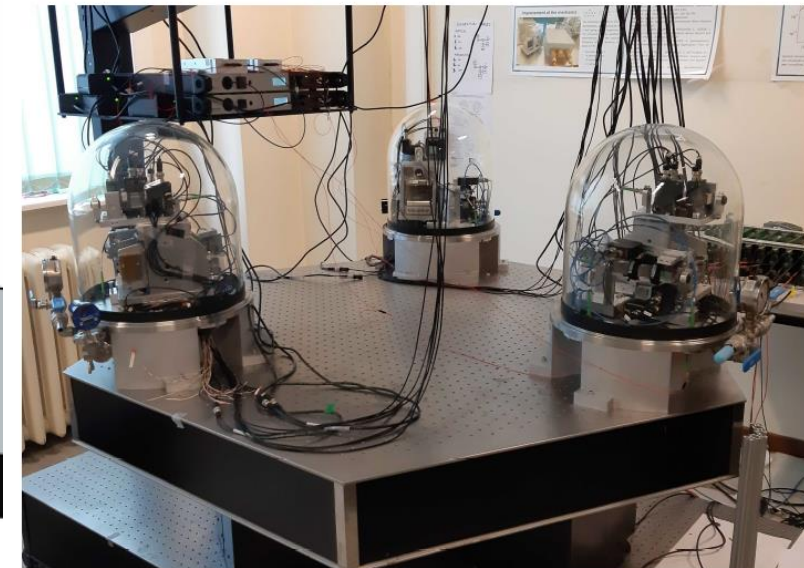
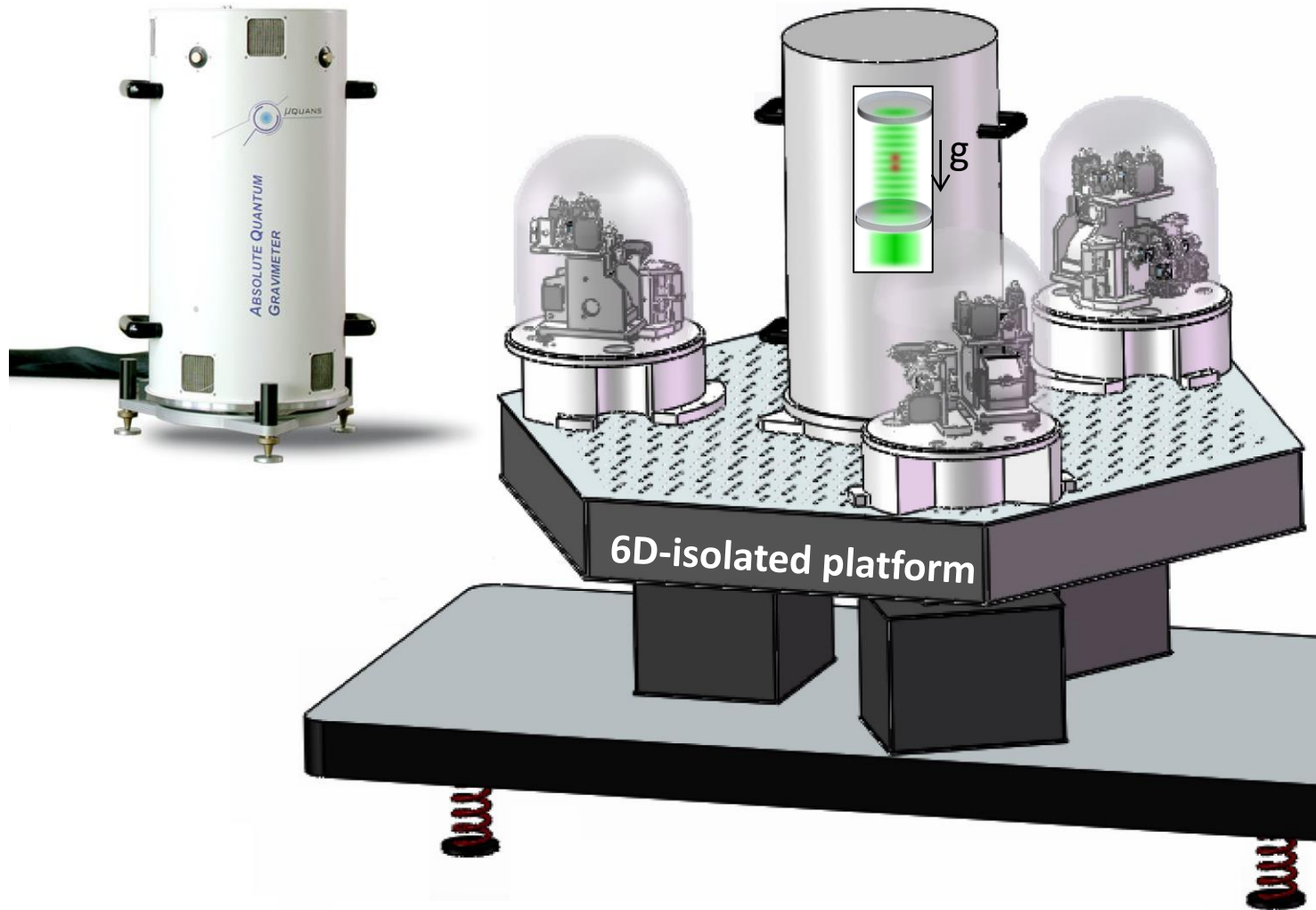

# 6-D isolation strategy

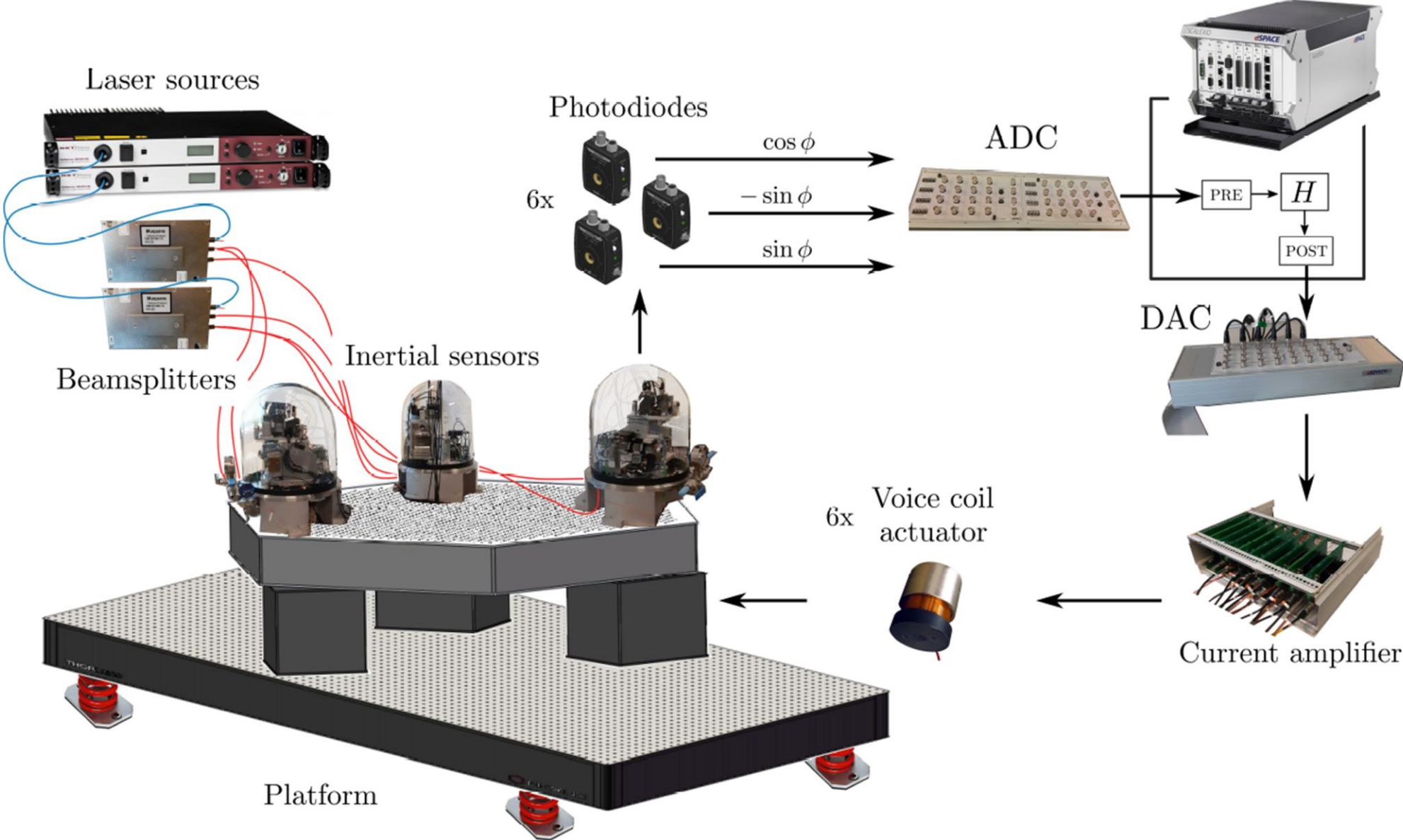

# Isolation performances

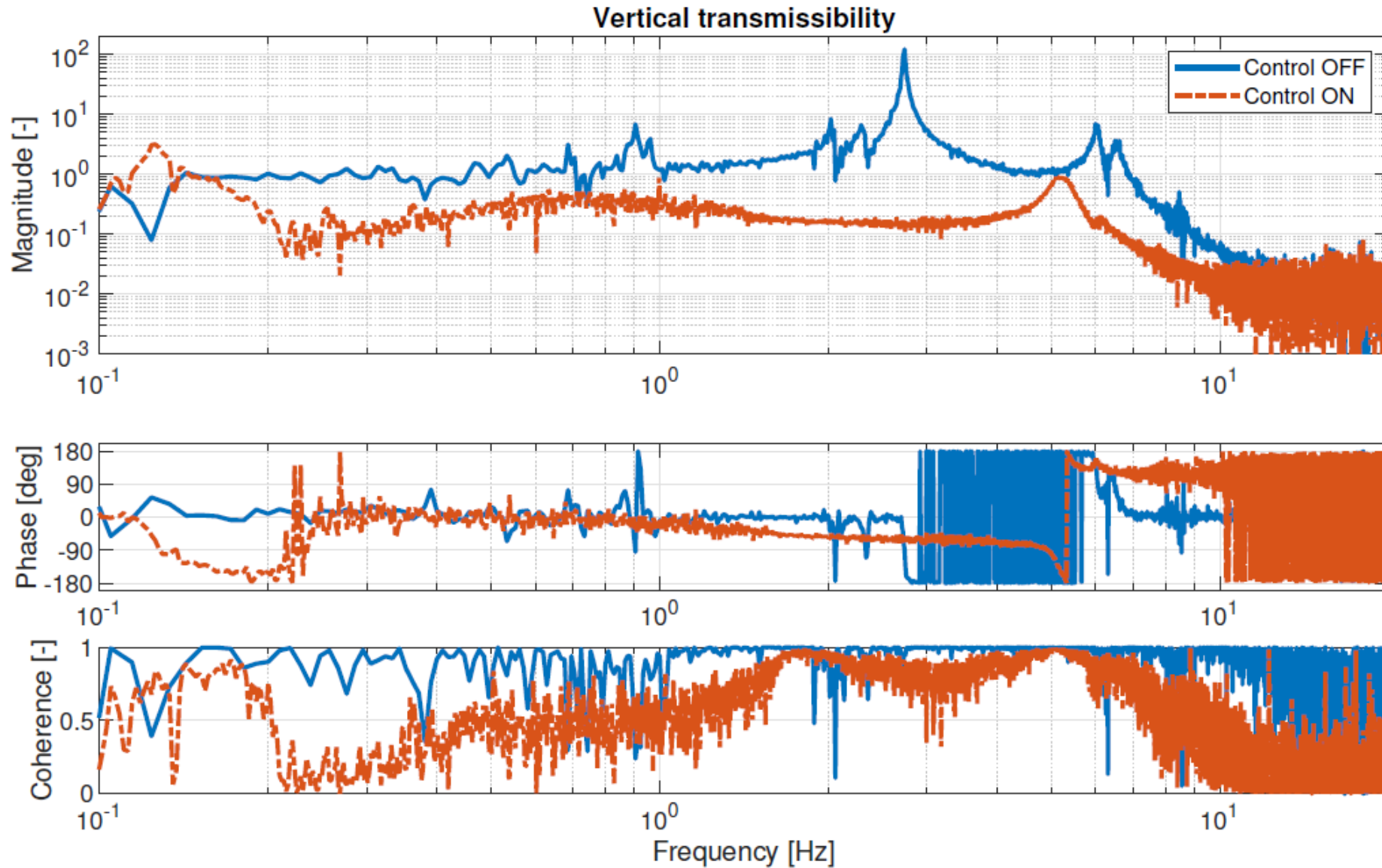



# References

---

[a] <https://www.muquans.com/news/deployment-of-our-quantum-gravimeter-on-mount-etna/>

[b] <https://www.usgs.gov/media/images/changes-earths-gravity-reveal-changes-groundwater-storage-0>

[1] Christian Freier, “Measurement of Local Gravity using Atom Interferometry”, PhD thesis, Technische Universität Berlin, Fakultät II - Institut für Optik und Atomare Physik, 2010.

[2] B. Ding, “Development of High Resolution Interferometric Inertial Sensors,” Ph.D. dissertation, Université Libre de Bruxelles, 2021.

[3] J. Lautier, L. Volodimer, T. Hardin, S. Merlet, M. Lours, F.P.D. Santos, A. Landragin, “Hybridizing matter-wave and classical accelerometers”, *Applied Physics Letters*, AIP Publishing, 105, 144102, 2014.

Long range Michelson interferometry and inertial sensing:

- J. D. Otero, “Development and Characterization of an Observatory-class, Broadband, Non-Fedback, Leaf-Spring Interferometric Seismometer,” Ph.D. dissertation, University of California, 2009.
- J. Watchi, S. Cooper, B. Ding, C. M. Mow-Lowry, and C. Collette, “Contributed Review: A review of compact interferometers,” *Review of Scientific Instruments*, vol. 89, no. 12, p. 121501, 2018.
- S. J. Cooper, C. J. Collins, A. C. Green, D. Hoyland, C. C. Speake, A. Freise, and C. M. Mow-Lowry, “A compact, large-range interferometer for precision measurement and inertial sensing,” *Classical and Quantum Gravity*, vol. 35, no. 9, p. 095007, mar 2018.

Quadrupoles magnets:

- N. Robertson, “Beamsplitter actuation: Potential use of shielding magnets.” LIGO Document T1500535, 2019.
- G. Fortman, “Instruments for seismic isolation,” Ph.D. dissertation, Delft University of Technology, 2019.
- A. Mitchell, “Coil drivers with shielding magnets in the 6d inertial isolation system,” LIGO Document T2100132, 2021.
- A. Mitchell, A. Ubhi, C. Mow-Lowry, and L. Prokhorov, “Coil drivers with shielding magnets in the 6d inertial isolation system,” LVK conference poster, 2021.

# Contacts

---

## Sensor development

- Anthony Amorosi, [anthony.amorosi@uliege.be](mailto:anthony.amorosi@uliege.be)
- Loïc Amez-Droz, [Loic.Amez-Droz@ulb.be](mailto:Loic.Amez-Droz@ulb.be)

Presenter, sensor actuation, optics and testing  
Sensor mechanics & fused-silica

## Quantum gravimetry and hybridizing

- Mayana Teloi, [mayana.teloi@uliege.be](mailto:mayana.teloi@uliege.be)

Quantum gravimetry and sensor hybridizing

## Active control activities

- Mouhamad Haidar Lakkis, [Mouhamad.Haidar.Lakkis@ulb.be](mailto:Mouhamad.Haidar.Lakkis@ulb.be)
- Ameer Sider, [asider@uliege.be](mailto:asider@uliege.be)
- Rasa Jamshidi, [r.jamshidi@uliege.be](mailto:r.jamshidi@uliege.be)

Control strategies  
Control strategies  
Control strategies

## Professor

- Christophe Collette, [chritophe.collette@uliege.be](mailto:chritophe.collette@uliege.be)

Supervisor (ULiège, ULB)

**Funding** Consolidator grant SILENT (grant agreement number 866259) & "Fonds de la Recherche Scientifique", Research project grant INFuSE (grant agreement number FNRS PDR T.0049.20).

The paper has been assigned the **LIGO DCC number P2200207**.

Thank you  
for your attention!