

(1)
ALTMANN, Roland (1)
MAQUOI, René (2)
JASPART, Jean-Pierre (3)

- IV/3 -

EXPERIMENTAL STUDY OF THE NON-LINEAR BEHAVIOUR OF BEAM-TO-COLUMN COMPOSITE JOINTS.

INTERNATIONAL COLLOQUIUM
STABILITY OF STEEL STRUCTURES
BUDAPEST, HUNGARY, 1990
PRELIMINARY REPORT

Summary : This paper presents the main results of an experimental research recently performed at the University of Liège, the aim of which was to analyse the behaviour till collapse of strong axis beam-to-column composite joints commonly used in practice.

1. INTRODUCTION

Many multi-storey frames are built now in such a way that the concrete floors contribute to the strength of the steel skeleton and participate to the structural behaviour of the framing.

Work performed in this field has however principally focused on the study of the individual frame components (columns and composite floors) and not so much on that of the connections between these elements. This has led the departments RPS of ARBED-Recherches (Luxemburg) and MSM of the University of Liège (Belgium) to introduce a two and a half years research project (01.07.87 to 31.12.89) to the Commission of the European Communities (agreement N° 7210-SA/507 C.E.C.-ARBED) in view to :

- investigate experimentally the behaviour under static loading and until collapse of 38 interior composite joints between a steel column and a floor composed of steel beams surmounted by a reinforced concrete slab on the one hand, and of 18 interior and exterior bare steel joints on the other hand;
- develop mathematical methods for the prediction of the non linear response till collapse of these joints on base of the knowledge of their mechanical and geometrical properties;
- develop a program for the non linear calculation of steel and composite frames with semi-rigid joints.

-
- (1) Engineer at ARBED-Recherches, Luxemburg
(2) Professor of Civil Engineering, University of Liège, Belgium
(3) Assistant, University of Liège, Belgium.

(2)

This paper presents the main results of the experimental part of the research dealing with the composite joints. Another paper is aimed at presenting the mathematical modelling of the behaviour of these joints.

Two types of cleat connections between steel beams and columns are considered; they only differ by the presence or not of one cleat connecting the upper beam flange to the column flange (figure 1). All the connections use bolts of quality 8.8 (H.S. bolts) preloaded with a specified torque moment associated to a not-controlled hand tightening.

A clearance of 1 mm is adopted between bolts and their holes while the clearance between the beam and the adjacent column flange is 15 mm.

The slab thickness is kept constant : 12 cm. Its breadth is fixed to 120 cm because of considerations dealing with the slab effective width.

Concrete strength has been kept as constant as possible and corresponds to normal concrete.

The concrete slab is connected to the steel beam by means of shear stud connectors allowing for a full interaction.

The continuity of the concrete slab at the column support is achieved by means of two layers of six rebars each.

All the mechanical and geometrical properties of the specimens have been measured but are not listed here.

The following parameters have been investigated :

- the type of sections used as column and beams: it was decided to use a single HE section (HEB 200) as column and IPE sections as beams, in accordance with a current practice for multi-storey buildings;
- the relative beam-to-column stiffness: because of the role played by the beam depth in the force distribution between the steel and concrete components of a composite joint (with a specified column section), three different beam depths are chosen : IPE 240 - 300 - 360.
- the sizes of the connecting cleats: for constructional and structural reasons, unequal leg 150 X 90 mm cleats are used, the larger leg being in contact with the beam. For sake of simplicity, all the cleats in a specified connection are identical. Two different values of thickness are considered with a view to assess the influence of the cleat flexibility:
 - a) 150 x 90 x 10 mm cleats
 - b) 150 x 90 x 13 mm cleats
- the percentage of steel reinforcement in the slab : three different bar diameters (10, 14 and 18 mm) have been selected in order to cover the current range : 0,67 % - 1,3 % - 2,1 %.

The collapse of the composite joints with IPE 240 beams being associated to the buckling of the lower beam flange and not to the collapse of the connection itself, therefore only the results of the test series with IPE300 and 360 beams are presented in this paper (see table 1).

part of the is aimed at e joints.

columns are at connecting loaded with a ghtening.

es while the 5 mm.

xed to 120 cm h.

orresponds to

f sh. r stud

achieved by

ns have been

ded to use a as beams, in s;

played by the and concrete tion), three

d structural leg being in cleats in a of thickness f tl cleat

ifferent bar to cover the

associated to lapse of the series with

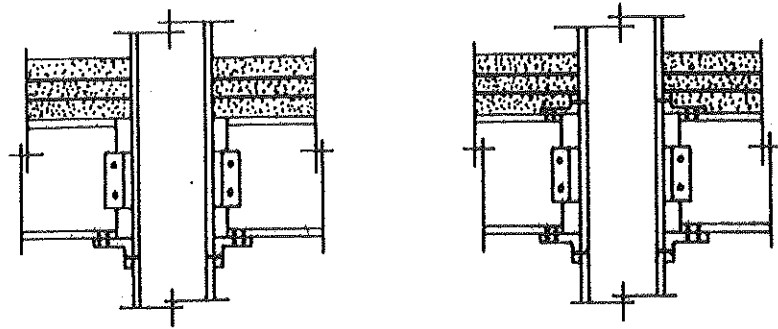

(a) composite joints with 2 cleats per connection (tests 30 x 2c or 36 x 2c) (b) composite joints with 3 cleats per connection (tests 30 x 3c or 36 x 3c)

Figure 1 - Types of composite joints tested in laboratory.

2. TESTING ARRANGEMENT

The experimental testing arrangement is given in figure 2. Beams and columns are guided laterally so that any displacement of the test specimen perpendicular to the plane of loading is prevented. The test specimen is loaded by means of a 50 tons jack, permitting a maximum vertical displacement of 20 cm.

The load is increased step by step either up to the collapse of the joint, or up to the maximum vertical displacement. Unloadings are carried out during the tests.

The specimens are instrumented as described in figure 2 and 3.

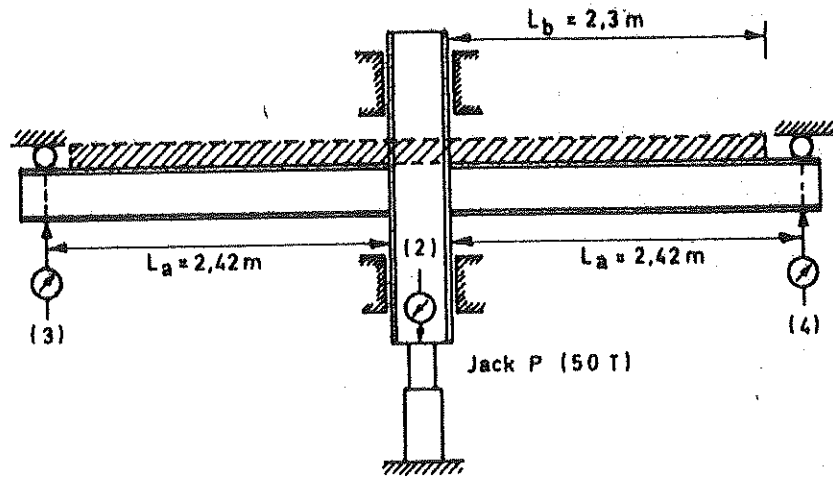

Figure 2 - Cruciform testing arrangement and location of displacement transducers.

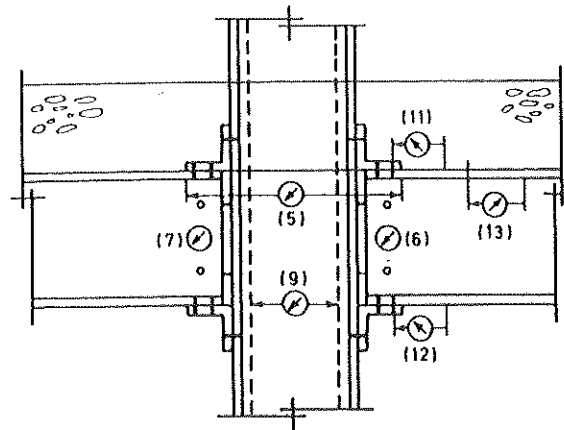

Figure 3 - Location of the displacement transducers and of rotation transducers (6-7) in the vicinity of the connections.

3. EXPERIMENTAL CURVES.

The following deformability curves have been plotted for each test performed (see figures 2 and 3):

- 1) M-w curve (w - vertical displacement of the column)

$$w = (2) - \frac{(3) + (4)}{2}$$

- 2) M- ϕ curve (ϕ - relative rotation of the connection)

$$\phi = \frac{(6) + (7)}{2} \text{ (first assessment)}$$

$$\phi = \frac{(5) - [(9) + 2 \cdot (12)]}{2H_b} \text{ (second assessment)}$$

where H_b - depth of the beams.

- 3) M- ϕ_{ws} curve (ϕ_{ws} - relative rotation without slip of the connection)

$$\phi_{ws} = \frac{(5) - (9)}{2H_b}$$

- 4) M- ϕ_{cz} curve (ϕ_{cz} - component of the connection rotation ϕ_{ws} due to the compression in the column web)

$$\phi_{cz} = \frac{(9)}{2H_b}$$

- 5) M- ϕ_{bf} curve (ϕ_{bf} - component of the connection rotation ϕ_{ws} due to the deformation at the upper beam flange)

$$\phi_{bf} = \frac{(5)}{2H_b}$$

For each test, the strains have been measured in the beam flanges and in the rebars (20 strain gages) in view to explore the stress distribution in

- (5) the two beam sections located just near the steel connections. This has enabled to report for each test ;
- (6) the mean values of the strains in the steel reinforcement of the concrete slab;
- (7) the mean values of the stresses in the steel reinforcement of the concrete slab;
- (8) the mean values of the stresses in the beam flanges.

It must be noted that the "connection relative rotation $M-\phi$ curve without slip" obtained by combination of the measurements n° 5 and 9 (figure 3) differs from the one which would result from another test on an equivalent connection but actually with no slip (cleats welded to the beam for instance); this may be explained by the dependence of the measurement n° 5 upon the slip value at the lower beam flanges.

4. INTERPRETATION OF THE EXPERIMENTAL RESULTS.

4.1. General description of the results.

The nature of the collapse for each specimen tested as well as the ultimate bending moment supported by the connections are presented in table 1. It may be seen that these maximum moments represent an appreciable percentage of the theoretical plastic moment of the composite beam sections.

The collapse of the partial-strength connections tested is linked up to the buckling of the transversally compressed column web or to the excessive yielding of the rebars according to the percentage of reinforcement in the concrete slab.

A brittle failure of sheared bolts has only been encountered for the test 30x2c.1; it seems to result more from a local problem of load distribution between the bolts connecting the lower cleats to the flange of the left beam than from an excess of stress in the bolts.

The test results highlight the importance of the flexibility of the connections due to the slip between the lower cleat and the beam flange. It is not very difficult and expensive to prevent such slip with the result of improved rotational characteristics of the composite connections tested in the frame of this research.

The two other components of the connection deformability registered during the tests in laboratory are related to :

- the compression in the column web ;
- the variation of the distance between the upper flanges of left and right beams (this measurement gives an idea of the concrete slab axial deformation).

The relative importance of these two sources of flexibility is strongly dependent on the percentage of reinforcement in the concrete slab.

of rotation
ions.

for each test

connection)

ϕ_{ws} due to the

ϕ_{ws} due to the

n flanges and in
distribution in

Test number	Thickness of the cleats (mm)	Diameter of rebars (mm)	Type of collapse ^x	M_{max}/M_p (%)	Test number	Thickness of the cleats (mm)	Diameter of rebars (mm)	Type of collapse	M_{max}/M_p (%)
30x3c.2	10	10	a, c	99	36x3c.1	10	10	a	77
30x3c.3	10	14	a	98	36x3c.2	10	14	a	80
30x3c.1	10	18	a	94	36x3c.3	10	18	a	79
30x3c.6	13	10	c (a)	114	36x3c.5	13	10	a	79
30x3c.8	13	14	a	95	36x3c.6	13	14	a	85
30x3c.7	13	18	a	95	36x3c.7	13	18	a	84
30x2c.2	10	10	c	81	36x2c.2	10	10	b	67
30x2c.1	10	14	d	89	36x2c.1	10	14	a	82
30x2c.3	10	18	a	94	36x2c.3	10	18	a	78
30x2c.5	13	10	c	79	36x2c.7	13	10	c	67
30x2c.6	13	14	a	99	36x2c.6	13	14	a	83
30x2c.7	13	18	a	94	36x2c.5	13	18	a	77

^x a: buckling of the column web at the level of the lower cleats ;
b: collapse (in tension) of the reinforcements in the concrete slab ;
c: attainment of the maximum permissible vertical displacement of the column (20 cm) due to the excessive yielding of the reinforcements in the concrete slab ;
d: collapse (in shear) of the bolts connecting the lower cleats and the beam flanges.

Table 1 - Description of the collapse for the performed tests.

4.2. Influence of the parameters chosen for the tests.

The parameters investigated in the experimental part of this research are the following :

- the thickness of the cleats ;
- the number of cleats ;
- the percentage of reinforcement in the slab.

The results of both presented test series (connections with IPE300 and 360 beams) lead to conclude to a similar influence of the here above recalled parameters according to the type of beam. Only the "IPE360 serie" will consequently be discussed in this paper.

Figure 4 for instance shows clearly the beneficial influence of the percentage of reinforcement on the rigidity and on the ultimate strength of the connections. The substantial rotation capacity of the composite connections with bars of 10 mm in the concrete slab is linked up to the tensile yielding of the rebars.

Figures 5 to 7 allow to highlight the influence of the cleat thickness on the semi-rigid behaviour of the composite connections. It may be seen that the rotational rigidity and the ultimate capacity of the connections are not strongly affected by this factor, more especially as the differences registered may be partly explained by :

- the relative importance of the slip between cleats and beam flanges ;
- the buckling direction of the column web, which influences the value of the collapse buckling load, and which is dependent on the initial out-of-plane deformation of the web, on its direction, and on the

(7)

position of the cleats connecting the beam web to the column (they are submitted to compression during the test and tend consequently to produce small bending moments in the column web).

The necessity to connect the upper flange of the beam to the column by means of a third cleat may be discussed on base of the diagrams of figures 5 to 7 too. The upper cleat do not affect significantly the behaviour of the connection (figures 6 and 7) as far as the plastic resistance of the rebars is not reached in the section of the connection and the associated plastic deformation has not developed. In the other cases (figure 5), an additional bending moment related to the resistance of the upper cleat submitted to tension forces is carried over to the column by the composite beams.

of apse	$H_{Max}/H_p (x)$
	77
	80
	79
	79
	85
	84
	67
	82
	78
	67
	83
	77

TESTS 36X20 - COMPARISON OF M - W DEFORMABILITY CURVES

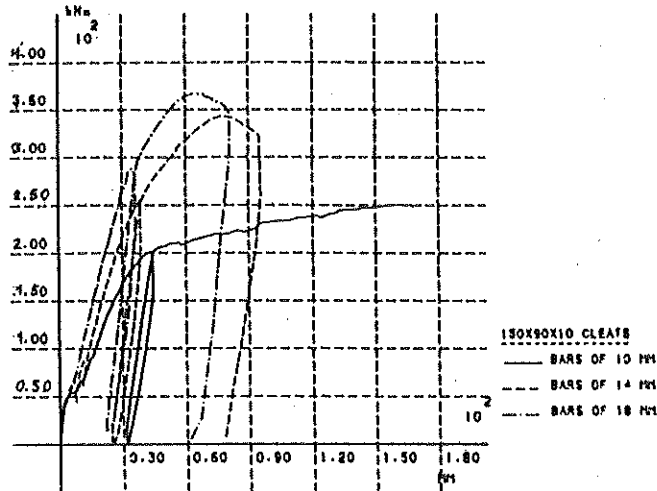

Figure 4-Influence of the percentage of reinforcement in the concrete slab.

TESTS 36X - COMPARISON OF M-W DEFORMABILITY CURVES

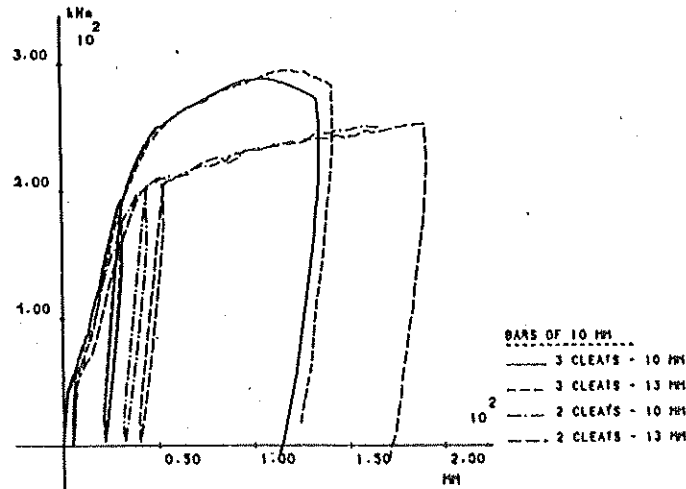

Figure 5-Influence of cleat thickness and number of cleat (rebars of 10mm)

100 and 360
ve recalled
serie" will

ce (the
strength of
composite
up to the

ickness on
seen that
ctions are
ferences

inges ;
a value of
ne initial
nd on the

(8)

-IV/10-

TESTS 36X : COMPARISON OF M-W DEFORMABILITY CURVES

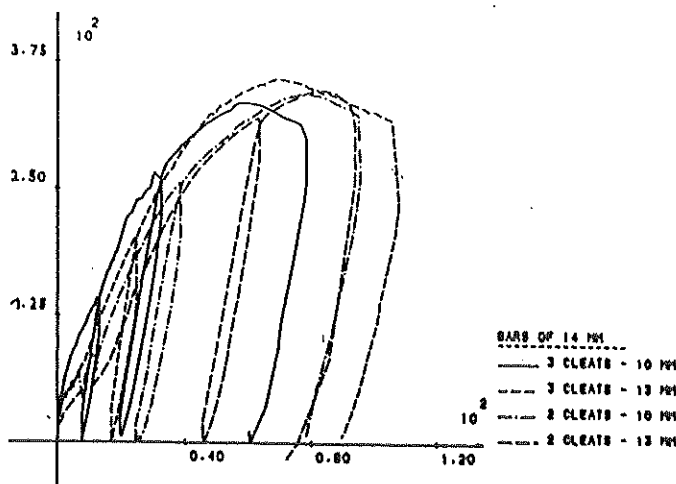

Figure 6-Influence of cleat thickness and number of cleats (rebars of 14mm)

TESTS 36X : COMPARISON OF M-W DEFORMABILITY CURVES

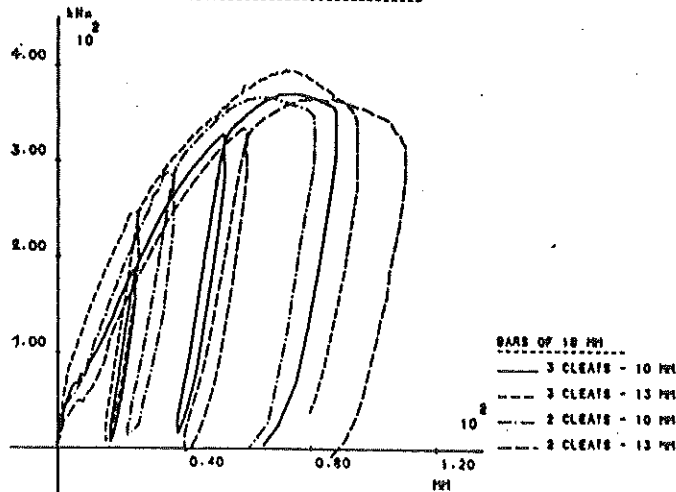

Figure 8-Influence of cleat thickness and number of cleats(rebars of 18mm)

(1)
DA'
HAJ
POS

Sum
stru
a f
pher
snow
this
steel
com
the
benc

In l
the
conc
on
of a

Gen

The
All
to
foam
proj
were
Tabl

(1)

(2)