



Contents lists available at ScienceDirect

Renewable and Sustainable Energy Reviews

journal homepage: www.elsevier.com/locate/rser

A qualitative assessment of integrated active cooling systems: A review with a focus on system flexibility and climate resilience

Essam Elnagar^{a,*}, Alanis Zeoli^a, Ramin Rahif^b, Shady Attia^b, Vincent Lemort^a

^a Thermodynamics Laboratory, Aerospace and Mechanical Engineering Department, Faculty of Applied Sciences, University of Liège, Belgium

^b Sustainable Building Design Lab, Dept. UEE, Faculty of Applied Sciences, University of Liège, Belgium

ARTICLE INFO

Keywords:

Cooling systems
Cooling demand
System efficiency
System flexibility
Climate resilience

ABSTRACT

Space cooling now has the fastest-growing energy end-use in buildings, with an almost tripled energy demand compared to 1990. This paper provides a state-of-the-art review of different integrated active cooling systems for buildings. The cooling systems are classified based on the energy source, with attention to the performance of the systems under multi-criteria assessment. The assessment criteria are described in five main parameters for energy performance, flexibility to energy sources and integration with secondary systems, climate resilience to heat-waves and power outages, as well as building typology, and technology readiness level. The qualitative assessment shows that electricity-driven systems are widely available in the market and have several applications integrated with PV systems. Therefore, they are more resilient to heatwaves. Only chillers are highly integrated with secondary systems among electricity-driven systems. The study also found that only air-cooled and water-cooled chillers can operate in passive cooling mode. It is found that thermal energy-driven systems are more flexible to be driven by different energy sources, in addition to being more resistant to power outages due to their low electrical input. Finally, some recommendations for further research and practice are given based on the study's strengths and limitations.

1. Introduction

Around 40% of the primary energy consumed in Europe is used in buildings and cooling energy requirements contribute significantly to the overall demand for electricity. There are several ways to cool the building using passive techniques such as shading, natural ventilation, evaporative cooling and various building designs to maintain a cool indoor. Another option is the use of electric fans to increase convective heat transfer around the body and therefore increase the body cooling by circulating air inside rooms but will not remove sensible or latent heat from the building. Currently, climate change has drawn great attention, with the predicted increase in global surface air temperature by the end of this century within a range of 1 and 5.7 K to (1850–1900) period under various Carbon dioxide (CO₂) emission scenarios [1,2]. Therefore, in hot climates, the use of active cooling systems (ACs) is still necessary to provide indoor thermal comfort and decrease indoor temperatures. In tropical climates, using natural ventilation with large window openings is not energy-efficient which encourages high energy use within the building [3]. Another study by Elnagar et al. [4] studied the natural ventilation effect in different climate conditions. The study found that,

only natural ventilation results in a low reduction in cooling energy demand. Therefore, controlled shading is taken into account with natural ventilation.

One of the largest energy consumers in buildings is ACs, which are essential for ensuring occupant comfort. Therefore, performance improvements to classic Heating, Ventilation, and Air-Conditioning (HVAC) systems present an attractive prospect for large energy savings [5]. Currently, various electricity-driven and thermal energy-driven cooling systems are commercially available in different climates. On extremely hot days, space cooling accounts for more than 70% of peak electrical demand in residential buildings in different middle eastern countries and some regions of the United States. Space cooling represented an average of 14% of peak demand globally in 2016 [6]. According to International Energy Agency (IEA), air conditioners and electric fans used to maintain acceptable indoor temperatures account for about 20% of the total electricity utilized in buildings worldwide today [6]. While, according to the International Institute of Refrigeration in Paris, the electricity usage for air-conditioning systems is estimated to be around 45% of the total electricity consumption of residential and commercial buildings [7,8].

Despite the availability of different cooling systems, vapour

* Corresponding author.

E-mail address: essam.elnagar@uliege.be (E. Elnagar).

Abbreviations

Active cooling systems	ACs
Vapour Compression	VC
Carbon dioxide	CO ₂
Energy Efficiency Ratio	EER
Seasonal Energy Efficiency Ratio	SEER
European Seasonal Energy Efficiency Ratio	ESEER
Coefficient of Performance	COP
Fan Coil Unit	FCU
Technology Readiness Level	TRL
Variable Refrigerant Flow	VRF
Electronic Expansion Valve	EEV
Heating, ventilation, and air-conditioning	HVAC
Photovoltaic	PV
Thermal Energy Storage	TES
Ice Thermal Energy Storage	ITES
Indirect Evaporative Cooler	IEC
Borehole Thermal Energy Storage	BTES
Aquifer Thermal Energy Storage	ATES
Ammonia	NH ₃
Lithium Bromide	LiBr

compression (VC) air-conditioning systems are the most widely used systems in residential buildings around the world [9]. In addition to electricity-driven cooling systems, thermal energy-driven cooling systems have been also commercially available in the market for many years based on the availability of a large amount of waste heat to operate the systems. Thermal energy-driven cooling systems are more coupled with renewable energy sources [10].

Previous studies have described various cooling technologies, some of them focused only on VC systems' performance [11–13], while other studies focused on thermal energy-driven cooling systems [14–16]. The most relevant results are shown in a study by Zhang et al. [11], the study conducted a comprehensive qualitative review of cooling techniques with a focus on their performance during heatwaves and power outages. Compression refrigeration technologies were part of the studied technologies, although the study didn't focus on the different types of compression refrigeration systems and their integration with secondary systems. Additionally, a study by Pezzutto et al. [17] investigated the recent advances in alternative cooling technologies using conventional VC systems. The study showed that there are no cooling technologies ready to compete with VC systems in the EU market between 2020 and 2030. Some studies showed that VC air-conditioning systems and refrigerators that are driven by electricity dominate the cooling technologies market by more than 99% [18,19]. Hughes et al. [20] assessed different sustainable active and passive cooling techniques in buildings. The study found that regardless of the significant advancements in active and passive cooling techniques, each technology has its limitations due to the climate conditions and electricity cost. While the study didn't discuss in detail the climate resilience of these cooling technologies. Oropeza-Perez et al. [21] investigated three active and ten passive cooling technologies for dwellings. It has been shown that, under certain outdoor conditions, passive cooling techniques can reduce indoor temperatures as effectively as ACs. In addition to that, a decision-making tool is created to select the optimum technology for the different buildings according to climate, the building type, and the cooling technology's initial cost. The study only took into account three factors, this assessment approach has some drawbacks such as occupants' behaviour, integration between the different technologies, and studying the performance of cooling technologies in severe events such as heatwaves and power outages. Kojok et al. [22] highlighted the most typical standalone cooling technologies used in hybrid cooling in buildings. The

study found that, in comparison to VC cooling systems used alone, hybrid systems based on VC offer significant energy savings and efficiency improvements. Standalone cooling systems have been found to occasionally be more efficient than hybrid ones. For instance, in extremely hot and dry climates, it is not essential to remove latent heat separately using a desiccant system, therefore the comfort level could be achieved with an electric or standalone absorption chiller. In addition to that, a thorough analysis of solar sorption cooling systems is presented by Bataineh et al. [23]. The study came to the conclusion that additional research is still required on solar sorption systems in order to make them energy and cost-competitive with conventional cooling technologies. Despite the numerous studies reviewing cooling systems, there is still a need for a thorough review study that defines and compares different cooling systems (electricity-driven and thermal energy-driven) systems in the HVAC research field. In addition, there is relatively little qualitative assessment discussing all parameters of energy performance, systems' flexibility, resilience to heatwaves and power outages, technology readiness level (TRL), and building type. Lastly, among the relevant studies of resilient cooling technologies, few of them have been discussing the different active cooling technologies and their integration with secondary systems.

This paper provides a valuable contribution by investigating and reviewing the state of the art of different electricity-driven and thermal energy-driven systems and assessing their performance based on the physical principles of each system including three main technical features (reversibility: possibility to reverse the machine to work as a heat pump, recovery: possibility to recover heat at condenser - simultaneous heating and cooling and passivity: possibility to make passive cooling) and different assessment criteria: energy performance, the flexibility of integration with secondary systems and renewable energies, climate resilience to extreme events such as heatwaves and power outages, building type and finally TRL. This paper also qualitatively compares the different cooling systems using those five assessment criteria.

The paper is organized as follows. In section 2, the ACs assessment criteria are presented. Section 3 explains the review methodology and the number of literature review studies in this paper. Section 4 presents the results of the electricity-driven systems (see section 4.1) and thermal energy-driven systems (see section 4.2). Section 5 presents the qualitative comparison between the different ACs. The key findings and recommendations are discussed in section 6 including strengths, limitations, and future directions. Finally, section 7 concludes the paper.

2. Active cooling systems assessment criteria

The following is a list of the parameters studied for each cooling system as shown in Fig. 1. When considering how to create a criteria matrix, various variables must be considered. The topic has been approached from many angles since different stakeholders would emphasize different selection criteria.

2.1. Energy performance

2.1.1. System efficiency

System efficiency is defined by different terms: *Energy Efficiency Ratio* (EER), *Seasonal Energy Efficiency Ratio* (SEER) and another similar standard to the SEER is *European Seasonal Energy Efficiency Ratio* (ESEER). SEER measures how efficiently an air conditioner operates over an entire season, it is a seasonally averaged value calculated from the measured EER values for different outdoor temperatures (20, 25, 30 and 35 °C). The higher the (S)EER, the more efficient the unit. For some cooling technologies, the performance is still measured by the Coefficient of performance (COP). The system efficiency of the AC system is expressed by the energy label with a scale from A+++ to D in some types, and A+++ to G in other types [24]. According to the COMMISSION DELEGATED REGULATION (EU) No 626/2011, "the energy efficiency classes for air conditioners, except for single ducts and double ducts

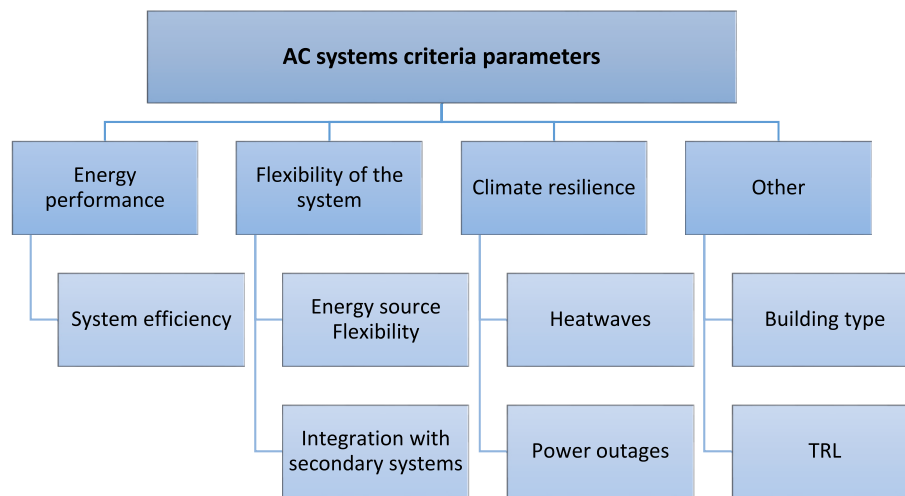

Fig. 1. Active cooling systems assessment criteria.

systems, start from SEER < 2.60 for G class to SEER \geq 8.50 for A+++ class” [24]. People regularly purchase air conditioners with average efficiencies of less than half of what is offered in all major marketplaces [6]. More efficient ACs cut CO₂ emissions from space cooling, especially when the systems are combined with cleaner energy sources.

2.2. Flexibility of the system

2.2.1. Energy source flexibility

One of the most promising strategies is the integration of multi-energy systems with different energy sources to meet buildings’ energy demands. This parameter considers the integration of different energy sources into the building as a hybrid system. It also considers the integration with renewable energy sources. The increasing usage of primary energy by conventional air conditioners is tackled by the introduction of renewable-based air-conditioning systems. The integration with renewable energies helps in reducing CO₂ emissions. This factor is qualitatively based on the flexibility of the primary AC system to be driven by different energy sources and to be integrated with different renewable energy sources.

2.2.2. Integration with secondary systems

This factor refers to the integration between the primary AC system components and the secondary systems such as fan coil units (FCUs) and radiant floor systems which makes the operating conditions/temperature for the system wider. While the integration with secondary systems can also affect the complexity of the system. This factor is qualitatively based on the flexibility of the primary AC system to be integrated with secondary systems as part of the large HVAC system.

2.3. Climate resilience

2.3.1. Heatwaves

Extreme events such as heatwaves have an effect on cooling systems and influence occupant indoor thermal comfort. This parameter explains cooling systems’ resilience and their ability to cope with such extreme events [11,25]. The World Meteorological Organization defines a heatwave as “five or more consecutive days of prolonged heat, i.e. with a daily maximum temperature at least 5°C higher than the average maximum” and some countries have adopted their standards [26].

2.3.2. Power outages

Cooling systems can fail to operate in case of disruptive events such as power outages. This parameter refers to the resilience of the different cooling systems to power outages and their ability to adapt after the

failure.

2.4. Other

2.4.1. Building type

Selecting the accurate AC system for a building does not only depend on the AC type but also on the building type. AC systems are installed in different building types such as industrial, commercial, residential and institutional buildings.

2.4.2. TRL

TRL is a system used to determine technology maturity, “TRL is based on a scale from 1 to 9, with 9 being the most advanced technology”, according to the U.S. Department of Energy’s Technology Readiness Assessment Guide [27]. This factor examines the different active cooling technologies’ readiness levels.

3. Review methodology

A comprehensive review is conducted to assess different ACs. A critical analysis of the available literature was used to conduct this review through different databases including Google Scholar, Web of Science Elsevier (Science Direct), SpringerLink and Scopus. Various keywords have been used for each cooling technology to perform the review. We have mainly focused on recent publications but there was no limit to the publication period. Table 1 shows the statistics of the reviewed literature to assess the systems.

4. Cooling systems

AC systems, as shown in Fig. 2, are classified into two main categories based on the energy source. There are electricity-driven AC units and thermal energy-driven AC units (heat, gas, etc.). Different types of

Table 1
Literature review statistics for the different cooling technologies.

Cooling Technology	Number of References	Publication Year
Split systems	36	1993–2021
Packaged Units	12	2004–2019
Air-cooled chillers	27	1996–2021
Water-cooled chillers	22	1981–2021
Evaporative cooled chillers	21	2005–2021
Sorption systems	15	1995–2021
Ejector cooling system	11	2011–2016
Desiccant systems	15	1992–2021

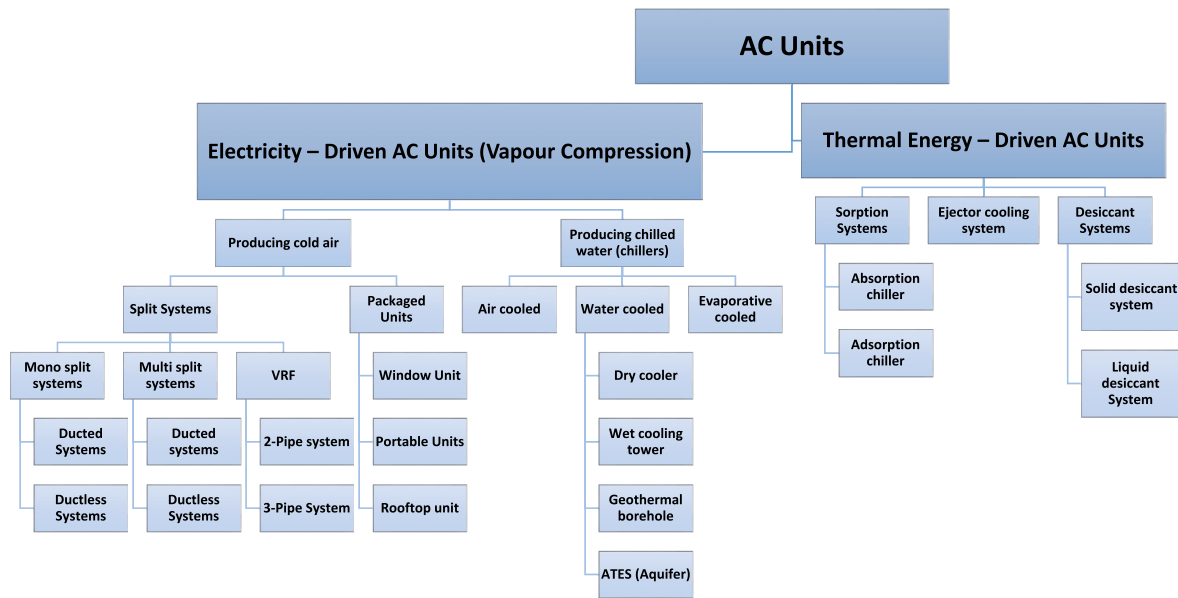

Fig. 2. Classification of active cooling systems discussed in this study based on the energy source.

electricity-driven AC units exist, i.e., systems producing cold air and systems producing chilled water. Thermal energy-driven AC systems include several types (sorption chiller, ejector cooling system and desiccant systems). Several energy sources are used to power the AC units: electricity, natural gas, heat, or solar power. In the 1960s, gas-powered air conditioner units were common. However, the most common way to power AC units is still by using electricity.

The compatibility of AC units to be driven by different energy sources is an advantage for some specific AC systems which is a key

factor in our assessment criteria related to the flexibility of the system. The different types of electricity-driven and thermal energy-driven AC units are discussed in this paper.

This section reviews the cooling technologies shown in Fig. 2 from the following aspects: the physical principle of each system, the assessment criteria shown above, and technical details regarding the possibility to reverse the machine to work as a heat pump, referred to as “REV”, the possibility to recover heat at the condenser (simultaneous heating and cooling), “REC”, and the possibility to make passive cooling,

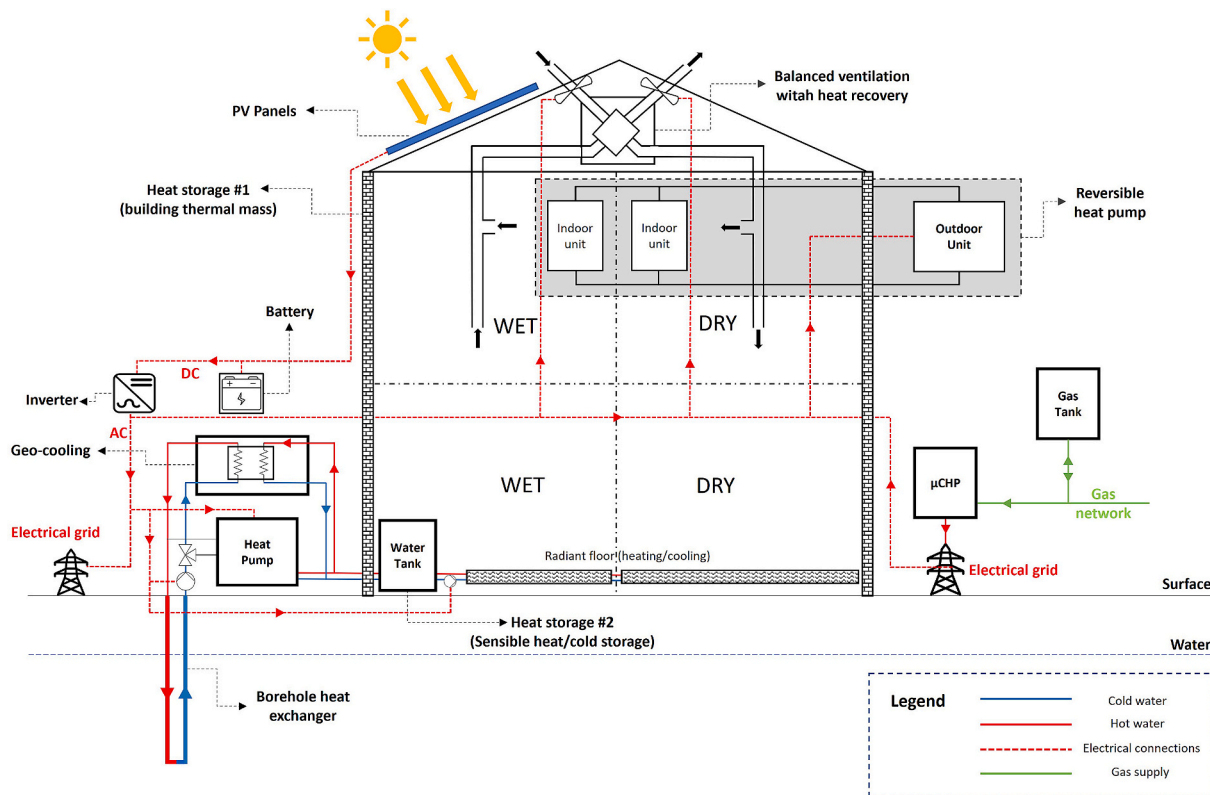

Fig. 3. Integrated electricity-driven cooling systems (primary systems) with secondary systems and renewable energy sources (this figure gives an overview of the common integration, but it is not generic).

“PAS”.

To give an overview of the systems' similarities and differences, a comparison matrix of the ACs is provided in Table 2. The cooling systems are compared based on the aforementioned parameters. The first section of the table provides technical details about the cooling systems regarding reversibility, simultaneous heating and cooling, and the possibility to perform passive cooling. Due to the binary nature of those characteristics, the comparison between systems is quite straightforward. The rest of the parameters are evaluated qualitatively by 'high', 'medium', or 'low' grades. The attribution of each system is based on the performance of this system compared to the average of the other cooling systems in the same category.

4.1. Electricity-driven AC units

Currently, the most common type of AC system mainly in residential buildings is the VC system which uses electricity as the energy source, *i. e.*, the first group in Fig. 2. In practice, the most common types of electricity-driven ACs are available in various configurations: split and packaged systems; ducted and ductless; stationary and portable.

Fig. 3 shows an example of the common integration between primary cooling systems (electricity-driven systems), secondary systems as well as renewable energy sources in a building. The electricity-driven system is represented in the figure by an indoor unit and an outdoor unit (see Fig. 4, Fig. 5, and Fig. 6 for the detailed schematics of electricity-driven systems). The figure also shows the 3 main types of ground coupling by using a borehole heat exchanger or dynamic aquifer or static aquifer. In addition to that, PV panels are used as an additional electricity source in the building to drive the heat pumps. Mechanical ventilation can also be provided by using for example a balanced mechanical ventilation system with heat recovery which sometimes can be bypassed. The integration also allows the heating or cooling of the building by radiant heating/cooling technology. The EER of electricity-driven AC units is calculated as follows in equation (1) [28]:

$$EER = \frac{\dot{Q}_{cool}}{\dot{W}_{elec}} \quad (1)$$

where.

- \dot{Q}_{cool} : is the cooling capacity of the system [kW]
- \dot{W}_{elec} : is the electrical power consumed by the system [kW]

4.1.1. Producing cold air

The systems that produce cold air are divided into two main

categories, split systems (mono/mini-split systems, multi-split systems and VRF systems), and packaged systems (window units, terminal units, portable units and rooftop units).

4.1.1.1. Split systems. A split system air conditioner is a reversible air source heat pump divided between one or several indoor units and one outdoor unit. Air-to-air AC means an air conditioner that uses indoor air as the cold heat source and outdoor air as the hot heat sink. In the split system, the condensing unit consisting of compressor and condenser coils is located outside the building, while the indoor unit consisting of an evaporator coil and air filter is located inside the building. In split systems, the secondary fluid in both the indoor units and the outdoor unit is air.

a Mono-split systems

Mono-split system is the simplest air-conditioning unit. It is designed to condition a small area or one room. It consists of one indoor unit including an evaporator and one outdoor unit including a condenser, a compressor and a fan. Mono-split systems are available in different cooling capacities ranging from approximately 3.5 kW–14 kW [29]. The schematic diagram is shown in Fig. 4 (a).

b Multi-split systems

A multi-split air conditioner means an air conditioner with an outdoor unit and one or more indoor units. The maximum cooling capacity of multi-split systems depends on the total number of indoor units, the capacity range is between 12 kW and 30 kW with 4 indoor units, but it could reach up to 50 kW with 6 indoor units [29]. The schematic diagram is shown in Fig. 4 (b).

Mono(mini)-split and multi-Split systems are both reversible systems and can work as heat pumps but without heat recovery. A 2-pipe Variable Refrigerant Flow (VRF) system is a reversible system without heat recovery similar to multi-split systems (therefore, it provides either heating or cooling according to the selected mode), while the heat recovery VRF system that provides both heating and cooling simultaneously, is the 3-pipe VRF system [30].

Among more than certified 3000 split reversible systems (≤ 12 kW) according to Eurovent certification, the SEER varies between 2.71 and 10.6 in some systems [31]. The EER has also a wide range between 2.11 and 6.45 [24].

Split systems (mono-split and multi-split) can also be divided into two main types.

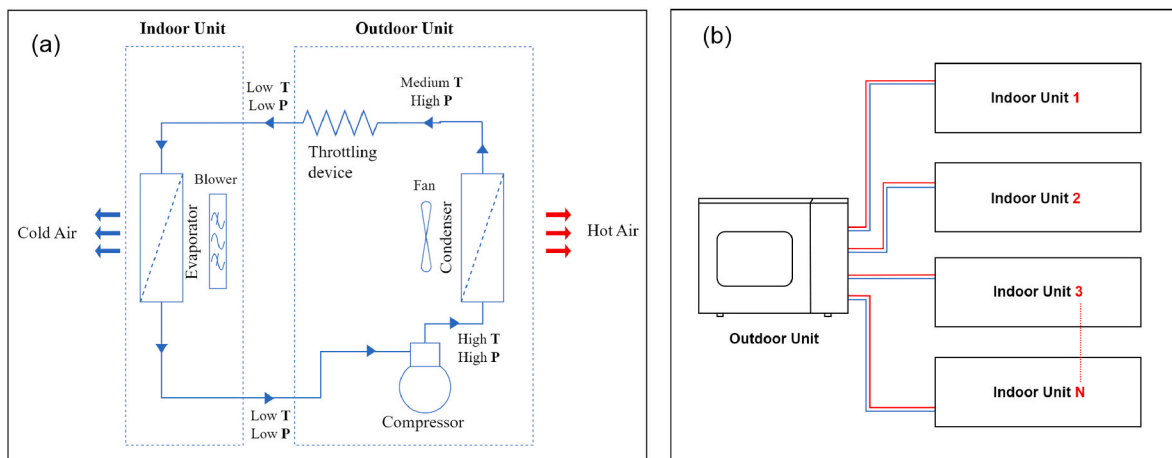

Fig. 4. Split Systems air conditioner (a) Mono-split system schematic diagram (b) Configuration of a multi-split system.

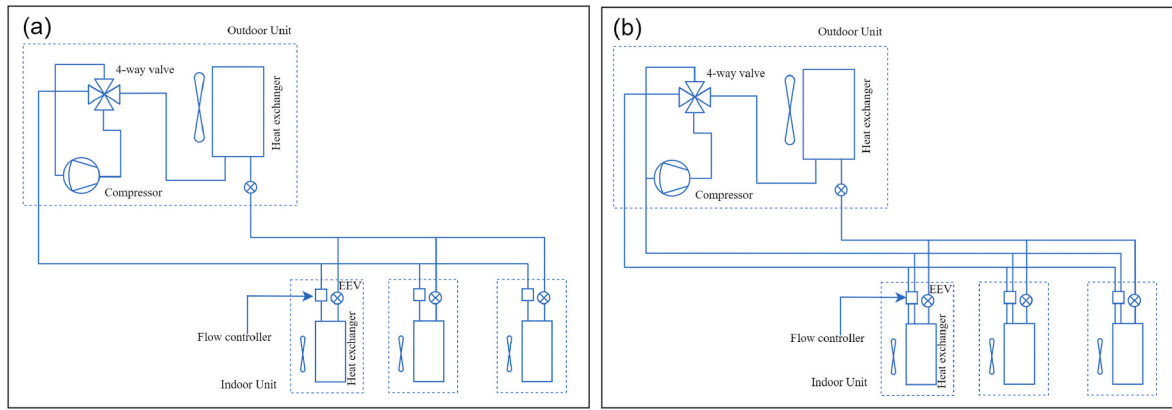

Fig. 5. VRF systems schematic diagram (a) two-pipe VRF system (b) three-pipe VRF system.

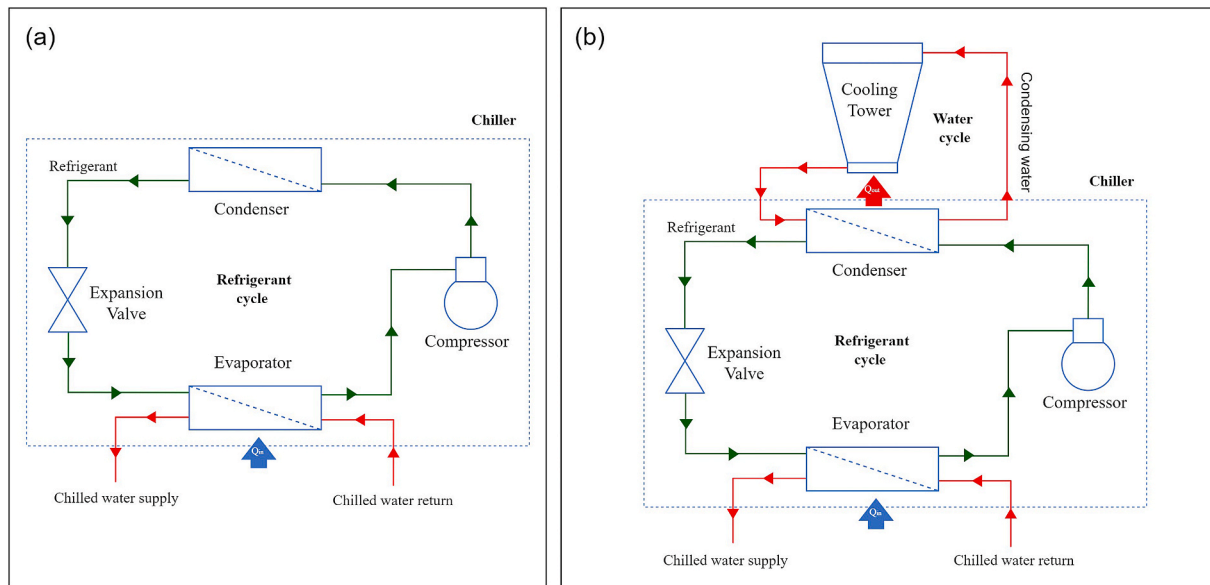

Fig. 6. AC systems producing cold water (chillers) (a) air-cooled chiller schematic diagram (b) water-cooled chiller schematic diagram.

- Ducted systems: in ducted split systems, the evaporator is located in a central location to provide cooling through a system of ducts in different building types [29].
- Ductless systems: ductless split systems provide space conditioning by distributing low-pressure refrigerant to one or more evaporators (typically up to four) located in conditioned spaces through a network of insulated refrigerant lines [29]. Ductless systems do not require any ductwork and could be installed anywhere. These units work in the same way as the traditional (ducted systems), just without the air ducts. Ductless split systems are the primary systems in residential buildings because of their small size and energy savings potential as they prevent duct air leakage from causing losses of conditioned energy. The performance of the ductless system depends on the appropriate placement of the indoor units. To moderately distribute the conditioned air around the room, the evaporator should be placed properly. Improper placement can result in ineffective space conditioning. Ductless multi-split systems allow for an energy consumption reduction compared to ducted systems. Multi-evaporator systems' zone cooling control allows for even more energy savings. Overall, the HVAC energy consumption is approximately reduced by 20% using a ductless AC system that operates at the same efficiency as a ducted split system [29].

Split systems are mainly powered by electricity, not gas, hence, they are not very flexible to different energy sources and usually rely on the electricity grid. However, they can be powered by other electricity sources such as PV panels or gensets (typically as a backup system as explained hereunder). Ductless split units are ideal cooling systems that can work with PV panels and they are widely used [32]. These systems have previously been developed as solar-powered air conditioner that operates using photovoltaic (PV) panels and commercial power supplies [32]. The most important finding was that by reducing the building cooling load, the size of the PV system required could be drastically decreased; by minimizing the cooling load by over 75%, the required PV array size was reduced by a factor of four [33].

In addition to that, split systems could be integrated with ice thermal energy storage (ITES) enabling the system to provide cooling without being connected to the grid for specific hours during the day. Ahmad et al. [34] showed that TES allows the split units to shift peak load and work during power blackouts for long periods, but the system is not commercialized yet and has a drawback of the large space needed to house the storage tank.

Extreme weather conditions can affect the cooling capacity of the system and its performance. Wang et al. [35] studied the impact of the outdoor air temperature on the COP of the split system, They showed that the COP decreases from 3.1 to 2.65 with the increase of the outdoor

temperature by 15 K from 30 °C to 45 °C. Hajidavalloo and Eghtedari [36] showed that an evaporative-cooled condenser could be used to maintain the cooling capacity of the split system at high temperatures. Abdelaziz et al. [37] assessed the COP for different refrigerants at high and extreme ambient temperatures for mini-split systems. The study showed that R-290 produced a COP 8% higher than the baseline with R-22 under extreme test conditions.

Since split systems rely on electricity, they are vulnerable to power outages on their own. Therefore, split systems alone are not extremely resilient to heatwaves and power outages. To increase this robustness as previously mentioned, integration with renewable energies such as solar-powered systems, integration with thermal storage such as ITES or cold-water tanks, integration with electrochemical batteries, or integration with backup gensets is required for providing enough backup power for full operation during a blackout.

Overall, split systems have a wide range of systems and capacities that are available to cool all types of buildings (residential and commercial) with an advantage to ductless systems over ducted systems, which shows TRL 9 for split systems.

c VRF Systems

VRF systems operate on the direct expansion principle that uses one compressor-heat exchanger (outdoor unit) and possible numerous heat exchangers (indoor units) controlled by controllable expansion valves to provide cooling (evaporator mode) and heating (condenser mode). The mass flow rate is controlled by the electronic expansion valve (EEV). In reaction to zone thermal measurements, this allows the VRF to be changed. Since the cycle in VRF systems is reversible so they can operate as reversible heat pumps, and the cycle can provide heating and/or cooling [38].

VRF systems are generally characterized by a higher cooling capacity than traditional split systems with cooling capacities mainly over 12 kW and can reach more than 60 kW [39]. VRF systems with a Eurovent Certified Performance have EERs varying around 3–4 [40]. There exist two types of VRF systems as shown in see Fig. 5.

- 2-pipe system: with a 2-pipe system, the whole system is either cooling or heating. The schematic of the 2-pipe system is shown in Fig. 5 (a).
- 3-pipe system: with a 3-pipe system, there can be both heating and cooling in different zones as shown in Fig. 5 (b). Generally, the 3-pipe system is the most popular because it gives greater control. It is also better if some rooms constantly require cooling while other areas may vary between heating and cooling requirements depending on the weather. VRF systems can transfer “heat” and “cold” according to the local need with very low energy consumption.

There are various working modes for VRF systems to provide only heating, only cooling, or heating and cooling simultaneously. In the first working mode (cooling mode only), all the indoor units work in cooling mode only while in the second working mode (heating mode only), all the indoor units work in heating mode. In addition to that in some cases for the 3-pipe VRF system, there is a heat recovery mode with cooling demand equal, higher, or lower than the heating demand, in this case, some indoor units work in heating mode while the others work in cooling mode depending on the demand.

Compared to conventional air-conditioning systems, these systems can control room-to-room temperature [41], without the use of air and water distribution circuits. A 3-pipe VRF system may deliver both cooling and heating simultaneously. However, VRFs have several drawbacks compared to air and water distribution systems. They can have much longer refrigerant pipes, hence a higher refrigerant charge and higher refrigerant pressure drop along the pipes and they also have a more complex control system [42].

4.1.1.2. Packaged units. Packaged air conditioners are also known as unitary systems. The evaporator, condenser and compressor are contained in a single box assembled at the factory site, which ensures the high quality of the packaged unit. Moreover, refrigerant charging is also done at the factory, avoiding potential issues linked to piping, evacuation, refrigerant charging, and leak testing onsite. The unit can also be shipped very easily to the site. Overall, the resulting benefit of packaging is cost reduction [43]. Packaged ACs can have various sizes, ranging from single-room units that can fit through a window to large rooftop units that can cool an entire building [6].

Similar to split systems, packaged unit systems can be reversible but cannot be used to recover both heat and cold.

Faramarzi et al. [44] evaluated the performance of packaged rooftop air-conditioning units at high ambient temperatures. They used six units coming from three different manufacturers. The standard units had a SEER of around 2.9 and an EER of around 2.5 while the SEER and EER of high-efficiency units were around 3.7 and 3.2 respectively.

Packaged AC systems can be integrated with thermal energy storage (TES) systems. TES systems can shift electric demand to off-peak hours and come with energy savings. TES also offers the opportunity to improve renewable energy systems integration. The integration could be measured with source energy reduction, fossil fuel consumption reduction, emissions reduction, and cost-effectiveness [45]. Regarding resilience to heatwaves, packaged AC systems are similar to split AC systems.

Packaged units are widely available on the market with a large range of systems and capacities to cool all types of buildings. Although they are more popular in the US than in Europe where packaged systems represent only 5% of the AC market share [39]. Overall Packaged systems have a TRL 9.

According to IEA [6], the main packaged ACs are divided into four main types.

a Window units

Window units can fit into a standard window frame due to their compact size and are sometimes called “through-the-wall” units. Window air conditioners are usually used for small air-conditioning capacities of up to 17 kW [46].

b Terminal units

Packaged terminal ACs are characterized by a large unit under a window that has a grilled opening that passes through the wall connecting the condenser and the evaporator [47].

c Portable units

Portable units are designed to be easily carried inside a building, with a tube to remove the unit’s heated air to the exterior [6,47].

d Rooftop units

Rooftop units, or outdoor packaged units, are larger systems that use ducts to deliver cold air into the building. Those units are commonly used in places like restaurants, homes, small halls, etc. They have higher cooling capacities than window units, up to 50 kW [46].

4.1.1.2. Producing cold water (chillers)

Chillers are large ACs that produce and distribute chilled water through a cooling network, made up of pipes and heat exchangers, to terminal units and cooling coils in air handling units that cool the indoor air. The main advantage of chillers is that they are very flexible regarding integration with secondary systems. They can easily be coupled with a thermal storage system (generally ice or chilled water) to shift the energy usage of the HVAC system from on-peak to off-peak periods [5]. Depending on the requirement of the terminal unit they

can also provide water at a higher or lower temperature. Low-temperature systems such as cooling coils require water around 7 °C while high-temperature systems such as radiant ceilings use water at 18 °C [48]. If connected to an ice storage system, the temperature of chilled water is typically around −5 °C during charging (an aqueous solution of glycol, also called brine, must be used). Similarly, as air-conditioning systems, chillers are electricity-driven, they are not very flexible to energy sources, but they can be partly or entirely powered by PV panels or other renewable energy sources.

Electricity-driven water chillers are vulnerable to power outages. As already mentioned, their robustness can be increased by integration with renewable energies or TES to provide enough backup power for full operation during a blackout. They could also be backed up by some gas-driven or diesel-driven gensets, in case the system cannot be stopped.

Chillers have a wide range of systems and capacities that are available to cool all types of buildings (residential and commercial), which gives them TRL 9.

There exist several types of water chiller systems that vary depending on the way the heat harvested in the building is evacuated. The heat evacuation is done through the condenser, which can be either air-cooled, water-cooled or evaporative-cooled. The main characteristics, advantages and drawbacks of those types of systems are described hereunder, as well as their energy performance.

4.1.2.1. Air cooled. In air-cooled chillers, one or more fans are used to cool the condenser coils as the heat generated by the refrigerant is rejected directly to the outside air. The air-cooled condensers use ambient air to absorb the sensible and latent heat energy dissipated by the refrigerant during the process of condensation. Since convective heat transfer coefficients are lower with air than with water, the air-cooled condensers are larger and mostly less efficient compared to water-cooled condensers in average operating conditions. The air-cooled chiller schematic is shown in Fig. 6 (a).

This system is more often installed in smaller chiller plants, generally below 700 kW, because space, water treatment, additional maintenance cost and initial cost associated with the cooling tower, and condenser water pump outweigh the energy benefit. The EER of typical air-cooled systems varies between 2.8 and 3.1 [49]. This efficiency is strongly linked to the outdoor temperature and the part-load ratio of the chiller. The energy efficiency decreases at higher ambient temperatures and sometimes at part load.

Compared to water-cooled condensers, it operates at a higher condensing temperature; hence the performance of the compressor of the refrigeration system is 15–20% lower. The condensing pressure can be decreased by increasing the fan speed of the condenser, hence decreasing the energy consumption of the compressor. However, it simultaneously increases the consumption of the fan and a trade-off has to be found.

Another drawback related to the higher condensing temperature is that air-cooled chillers are generally less resilient to heatwaves than water-cooled chillers. Using the outdoor air as a cooling medium means that the system performance is strongly dependent on the outdoor conditions.

4.1.2.2. Water cooled. In water-cooled chillers, heat is rejected to water, which is pumped to a dry-cooler or a wet cooling tower and circulated.

It is proven that water-cooled chillers are more energy-efficient compared to air-cooled chillers. Water-cooled condensers are smaller than air-cooled to provide the same cooling effect and they are also more efficient. Generally, they can operate at lower condensing pressure, since the theoretical water temperature limit is the wet bulb of the outdoor air. However, it could become untrue in case of large pinch points between the heat exchangers.

Another advantage of water-cooled chillers is that they can be

bypassed to perform free chilling. The cold water that is produced to cool the condenser of the chiller can be directly or indirectly (by heat exchanger decoupling) used in the terminal units [50]. Generally, water-cooled chillers have higher capital costs than air-cooled chillers.

The EER of water-cooled chillers is generally between 4.9 and 7.8 [49]. As for air-cooled chillers, the chiller energy efficiency drops when operating at part loads and more significantly at a very low part load below 30%, but it depends on the load control mechanism based on the type of the compressor, in addition to that, the efficiency also decreases at higher condenser water temperatures. The water-cooled chiller schematic is shown in Fig. 6 (b).

a Dry cooler

Due to several reasons, such as environmental regulations or water consumption restrictions, air-cooled condensers, and especially natural draft dry cooling towers, are becoming a more favourable choice for power plants even though they show reduced efficiency at high ambient air temperatures [51,52]. During hot days, it is possible to improve the efficiency of dry cooling towers by using techniques such as water spraying [53,54].

b Wet cooling tower

Cooling towers rely on water evaporation. As such, circulating water can potentially be cooled down to the outdoor air wet-bulb temperature. Compared to dry cooling towers, wet cooling towers are more effective and have a substantially smaller surface area [55]. However, the water consumption of wet cooling towers is larger due to evaporation, drift and draining losses [56]. There is approximately 1% evaporation from the total water flow for each 7 K temperature change in the exhaust water temperature of the cooling tower [57].

Cooling towers can be either natural or mechanical drafts, meaning that the airflow through the cooling tower can be induced either by natural means or with fans [58]. Less space is required for mechanical draft cooling towers than for natural draft ones but the fans require electrical energy, which comes with higher energy consumption (fan power is approximately 1.8% and the pump power 0.2% of the cooling capacity) [59] and higher operating costs [60].

The Performance of wet cooling towers can be further enhanced by pre-cooling the air entering the tower. Pre-cooling of the air can be done through an “indirect evaporative cooler” (IEC), which consists of a water-to-air heat exchanger. Part of the cold water produced by the cooling tower is diverted and used in the IEC to pre-cool the outside air entering the tower. In such a configuration, the temperature limit of the circulating water becomes the dew point of the outdoor air, rather than the wet bulb temperature [61].

c Geothermal borehole

The temperature of the earth remains relatively constant at depth, being warmer than the air temperature in winter and colder in summer. Geothermal boreholes allow rejecting heat in the ground to provide a lower temperature heat sink than outdoor air [5].

Borehole thermal energy storage (BTES) systems can also be used for seasonal TES by transferring heat or cold to the ground. Heat and cold can be stored in the ground over either short-term or long-term periods at a rather low cost. When the ground temperature is higher than the temperature at which chilled water should be provided to the terminal units, a chiller must be used to provide chilled water to the conditioned space at the desired temperature. If the temperature of the ground is low enough, it is possible to perform passive cooling (called “geocooling”), which can be the case if a high-temperature emitter is used, such as radiant panels or chilled beams. Available low ground temperatures will result from the history of heat extraction during the heating season. In geocooling mode, the cooling system consumes low amounts of energy

[62], associated with water-circulating pumps, leading to typical SEER values of 12 or more.

BTES is mainly used for combined heating and cooling, typically in well-insulated office buildings which have cooling requirements in summer due to high internal heat gains. The heat is then delivered to the BTES for seasonal storage. To avoid temperature drifts in the ground, heating and cooling loads should be balanced over the year [63].

d Aquifer thermal energy storage (ATES)

ATES is, on the contrary, an open-loop cooling solution that depends on the existence of an aquifer. It consists of at least two separate wells, one for the extraction of groundwater, and another for the reinjection [64].

During winter, cold can be stored in the aquifer, for example with a heat pump that extracts heat from the aquifer to cover the heating needs in the building. In summer, the stored cold can be used for cooling purposes. In static aquifers, thermal energy is stored seasonally. In dynamic aquifers, however, there is a flow of underground water that ensures a constant temperature of the water but prevents seasonal storage. The main advantage of this technique is that during the cooling season, it is sometimes possible to perform passive cooling by taking advantage of the sufficiently cold ground water temperature. In this case, the chillers are unnecessary, resulting in large energy savings. In most cases, the use of chillers is significantly reduced, which leads to major savings on electricity [65].

4.1.2.3. Evaporative cooled. Hybrid evaporative air-cooled condensers are a combination of a cooling tower and an air-cooled refrigerant condenser that takes the profit of adiabatic cooling. The hot refrigerant gas passes through a “tube to plate” design evaporative condenser and water cascades over its surface. Air is drawn through the condenser and some of the water evaporates causing heat transfer. In comparison to an air-cooled system, the evaporative condenser results in a lower condensing temperature. As a result, it is considerably more efficient than air-cooled condensers.

Compared to water-cooled condensers, this system eliminates cooling towers and condenser water pumps, saving initial and operating costs for additional auxiliaries.

Hajidavallo and Eghtedari [36] experimentally showed that an evaporative cooler coupled with an air-cooled condenser can reduce the power consumption of the air-conditioner by up to 20% and increase the system EER by 50%. They also showed that evaporative-cooled chillers are less sensitive to outdoor air conditions than dry air-cooled chillers.

Youbi-Idrissi et al. [66] modelled a sprayed air-cooled condenser coupled to a refrigeration system. They showed that compared to a dry-cooled air condenser, the EER and calorific capacity of the system increased by 55 and 13% respectively.

Yu and Chan [67] investigated the usage of mist pre-cooling to improve the EER of air-cooled chillers. They estimated that the annual energy usage could be decreased by up to 18%.

4.2. Thermal energy-driven AC units

The different types of thermal energy-driven systems are shown in the second group of Fig. 2. There are different cooling techniques driven by low-temperature heat sources, including absorption, adsorption, desiccant, and ejector cooling systems. Absorption is the most extensively utilized of these methods, accounting for 59% of installed thermal-energy-driven systems in Europe, compared to 11% for adsorption and 23% for desiccant cooling [68].

The electrical energy input of thermal energy-driven cooling systems often is negligibly small. Therefore, the electrical COP (COP_{elec}) can be used to distinguish it from the thermal COP (COP_{th}). COP_{elec} is defined as the amount of heat extracted by the evaporator divided by the amount

of electricity consumed as shown in equation (2) [69]. COP_{th} is defined as the amount of heat extracted by the evaporator divided by the amount of required heat by the system as shown in equation (3) [69].

$$COP_{elec} = \frac{\dot{Q}_{ev}}{\dot{W}_{elec}} \quad (2)$$

$$COP_{th} = \frac{\dot{Q}_{ev}}{\dot{Q}_{gen}} \quad (3)$$

As explained previously in Fig. 3 for the integration between the different cooling systems for the electricity-driven systems category. Fig. 7 also shows the integration between the primary (thermal energy-driven systems), secondary systems as well as renewable energy sources. The thermal energy-driven cooling systems are represented by sorption cooling systems, ejector cooling systems, and desiccant cooling systems (see Fig. 8, Figs. 9 and 10 for the detailed schematics of thermal energy-driven systems). There is also a connection between the thermal panel and biomass supply as energy sources for thermal energy-driven systems.

4.2.1. Sorption chiller

Sorption cooling systems are thermal energy-driven AC units as they use heat to produce cooling based on the solid and liquid sorption process. They could be classified based on the sorption mechanism into absorption and adsorption cooling systems. Absorption and adsorption cooling systems are similar to the traditional VC refrigeration systems, with the primary distinction being that heat rather than mechanical work drives the cycle [19].

The sorption cooling system has four main components: condenser, evaporator, generator and absorber components [70]. To extract vapour refrigerant from the high-pressure sorbent, heat is provided to the generator (high-temperature heat source). This heat is the energy input provided to the machine. The condenser condenses the vapour refrigerant, rejecting heat to the ambient (medium temperature heat sink). After the condenser, to reduce the pressure of the liquid refrigerant, the latter flows through an expansion valve to the evaporator where the refrigerant evaporates, producing a cooling effect (low-temperature heat source) [70]. Finally, the vaporized low-pressure refrigerant is absorbed by the sorbent, rejecting heat to the ambient (medium temperature heat sink). The schematic diagram of the sorption cooling systems is shown in Fig. 8. Due to the significant environmental characteristics, sorption cooling systems, especially adsorption chillers, are becoming more and more popular [71].

Sorption cooling systems can work as heat pumps since they could absorb heat at low temperature and pump it to a heat sink at medium temperatures [72]. In addition to that, they can offer heat recovery and be used for both heating and cooling purposes simultaneously [73].

There are two types of sorption cooling systems and both systems have similar components.

4.2.1.1. Absorption chiller. Absorption chillers use lithium Bromide (LiBr) or water as the absorbent fluid and water or ammonia (NH_3) as the refrigerant. The absorption chiller has a higher COP value than the adsorption chiller [71]. In the absorption chiller, a “thermal compressor” is used, rather than the mechanical compressor used in VC refrigeration systems as shown in Fig. 8 (a) [74].

4.2.1.2. Adsorption chiller. Adsorption chillers use silica gel, activated carbon or zeolites as the adsorbents and water as the refrigerant. Compared to absorption systems, adsorption systems are less sensitive to the temperatures of the heating source and the cooling water. The schematic of the adsorption chiller is shown in Fig. 8 (b).

Kuczyńska & Szaflik [71] analysed the COP of the absorption and adsorption cooling systems, the study showed that the COP varies with the temperatures of the driving source and cooling water. Absorption

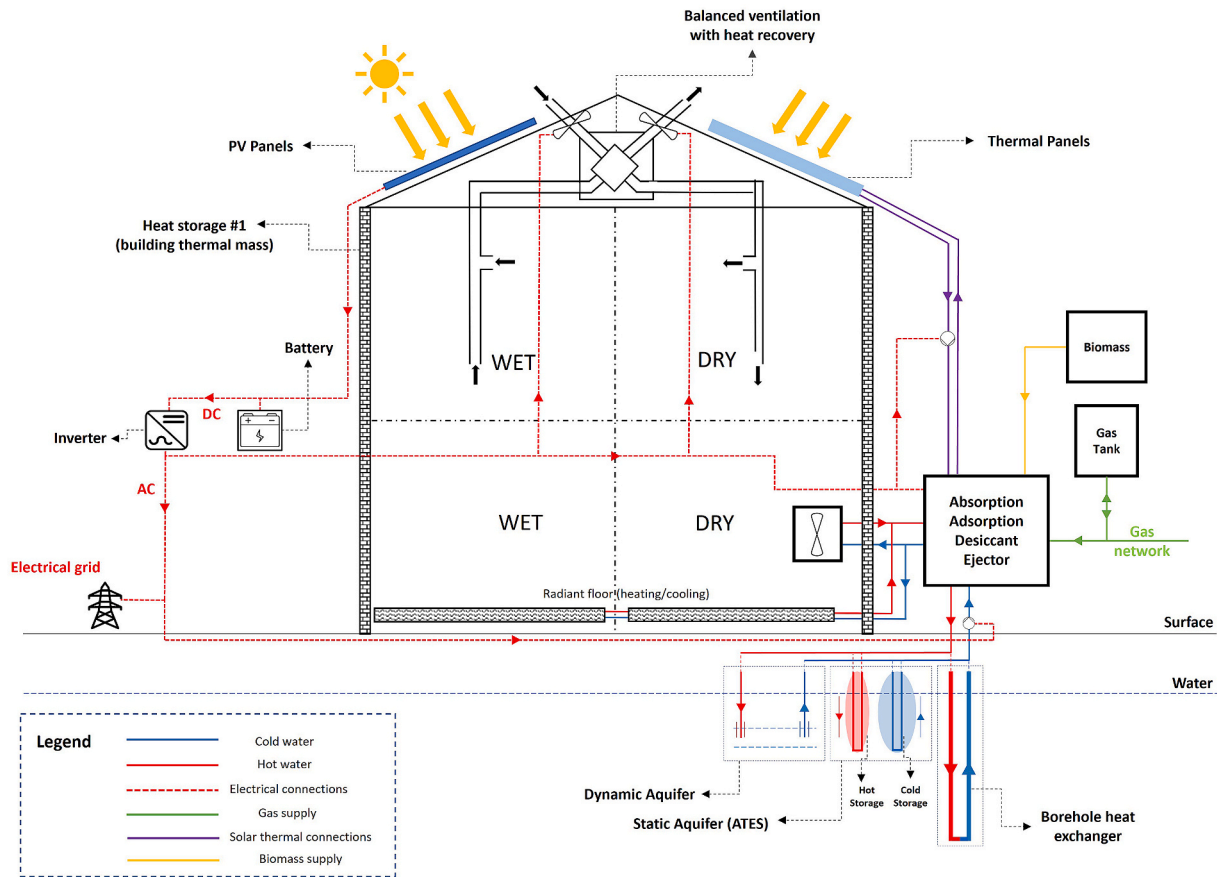

Fig. 7. Integrated heat-driven cooling systems (primary systems) with secondary systems and renewable energy sources (this figure gives an overview of the common integration, but it is not generic).

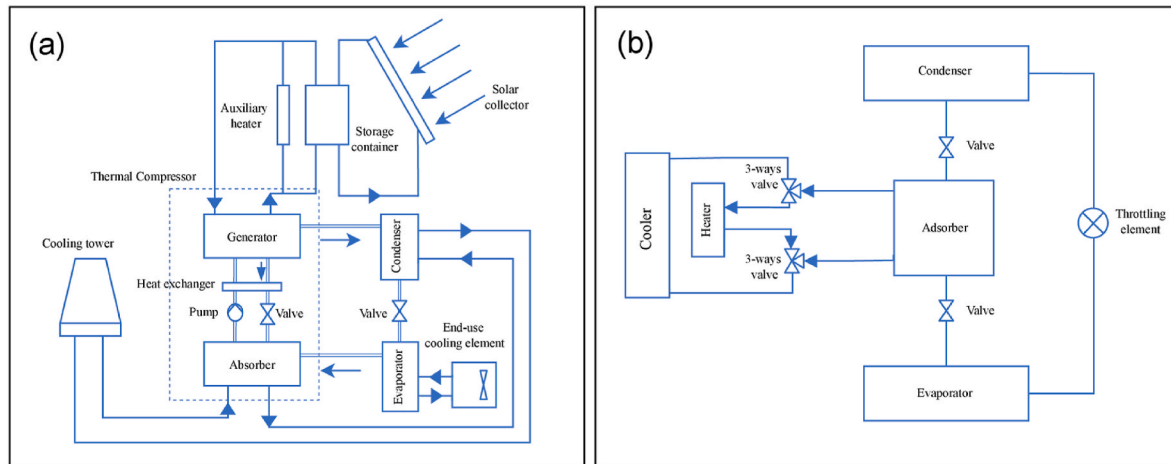

Fig. 8. Conventional solar sorption cooling systems schematic diagram (a) absorption chiller (b) adsorption chiller.

chillers reach higher COP values than adsorption chillers. The COP of the absorption chiller varies between 0.7 and 1.2 depending on the cycle configuration (single or double effect chiller) [75], while the COP for the adsorption chiller varies between 0.4 and 0.6 [71]. Pilatowsky et al. [72] discussed the various capacities of the different commercial systems of different manufacturers. Absorption and adsorption chillers are available in different capacities starting from 4.5 kW up to 30 MW depending on the manufacturer characteristics for the different systems [69,72].

Sorption cooling systems are energy source flexible systems as they could be driven by various energy sources, including solar energy. Low-

grade heat sources, such as waste heat, can also be used to power the sorption cooling systems [73,76]. Wang et al. [77] studied the LiBr–H₂O absorption cooling system's thermal performance using a Parabolic-trough collector. The study analysed how the steam flow rate affects the variations in the cooling capacity and COP. When the load factor changes from 20% to 100%, the COP increases from 0.89 to 1.32, which is the same for the absorption chiller driven by exhaust gas.

Heatwaves could decrease the cooling capacity and the efficiency of sorption cooling systems, Kim et al. [78] showed that the air-cooled half effect LiBr-water absorption chiller's cooling capacity in

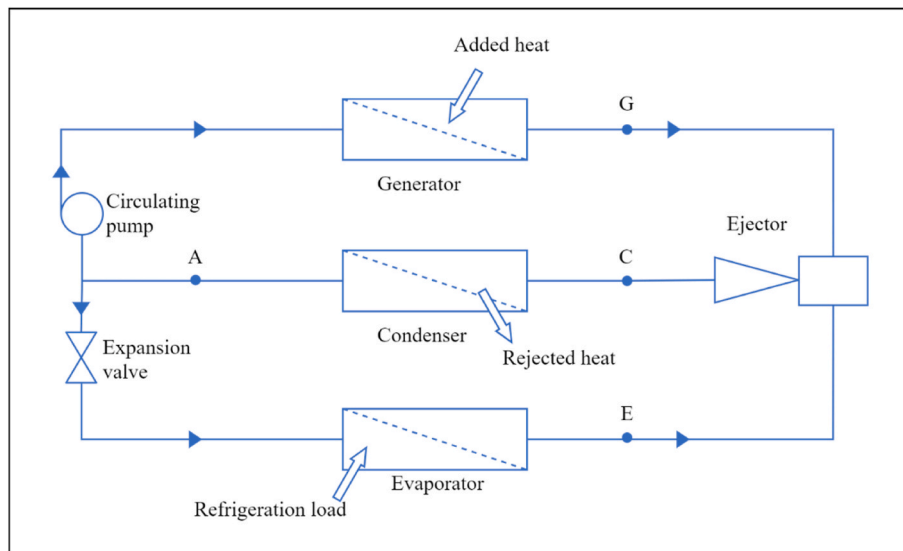

Fig. 9. Ejector cooling system Schematic Diagram.

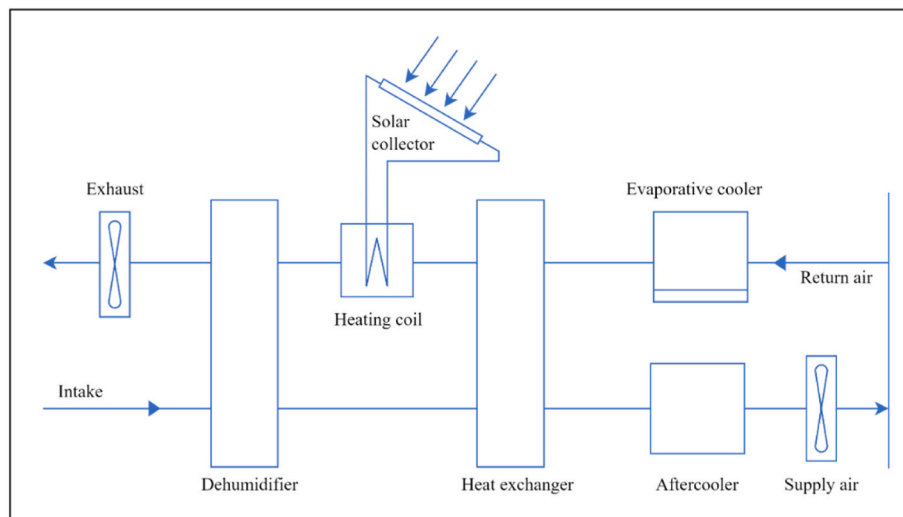

Fig. 10. Desiccant cooling system schematic diagram.

high-temperature conditions is 4.8 kW at 50 °C ambient temperature which is 62.5% lower than the cooling capacity at 35 °C ambient temperature (in case of the direct air-cooled chiller), while the cooling capacity for the indirect chiller at 50 °C ambient temperature is 3.2 kW (64.4% lower than the cooling capacity at 35 °C ambient). The cooling water distribution system of the sorption cooling systems, as well as a number of components inside the system, cannot be operated without an electrical power source, as a result, the system has medium resilience in the event of a power outage [11]. Resilience could be improved by connecting the sorption cooling system with solar systems like the assisted solar-absorption cooling systems where the electricity is provided by solar energy as electricity consumption (in kW_e per kW_{th} of cooling capacity) is much lower than for a conventional VC chiller. The sorption systems could also integrate local electricity production like the conventional compression refrigeration systems to operate during power outages [11].

In the past, there have been major manufacturers offering sorption cooling systems mainly for high capacities for commercial buildings and industrial applications. Currently, many companies developed chillers of medium and small capacities, therefore sorption cooling systems can be categorized in TRL of 3–9 [72,79].

4.2.2. Ejector cooling systems

The schematic diagram of the ejector cooling system is shown in Fig. 9. The cycle consists of an evaporator, a generator, an ejector, a condenser, an expansion valve and a circulation pump. The generator uses low-grade heat energy for vaporization, then, the high-pressure vapour (primary flow), enters the nozzle of the ejector and entrains low-pressure vapour from the evaporator (secondary flow). Both flows are mixed and undergo pressure increase in the ejector diffuser. They are then fed into the condenser. At the condenser outlet, the liquid is divided into two flows: the primary flow and the secondary flow. The secondary flow goes through the expansion device to the evaporator producing the refrigerating effect, while the primary flow is pumped back to the generator which completes the cycle [80,81]. The ejector can be used as a component of a refrigeration system, where it fulfils the role of a compressor [81].

The main advantage of the ejector is that it has no rotating component for compression or any other part that could require maintenance or lubrication. However, there are losses resulting from the direct interaction of two fluids moving at various velocities [81].

Those systems can be driven by low-grade thermal energy and enable the reduction of mechanical work requirements since the work of the pump can be neglected compared to the generator heat input [80,82].

The heat rejected at the condenser can be recovered to perform simultaneous heating and cooling, given that heat should be delivered at a lower temperature range (medium-temperature heat sink) than the generator heat (high-temperature heat source).

Ejector refrigeration systems are characterized by relatively low COP. Chen et al. [82] reported EERs ranging from 0.03 to 0.48 for cooling capacities up to 5 kW. Besagni et al. [83] presented a comprehensive literature review on ejector refrigeration systems. They provided a deep analysis of existing ejector technologies and their influence on ejector performance. Over more than 30 studies on ejector refrigeration systems, it appears that the EER varies within the range of 0.02–0.85.

The generator of the refrigeration cycle can be fed by various heat sources. Ejector refrigeration systems can be coupled with solar heating. The main advantage of solar energy is the temporal coincidence between heat input and cooling load. However, the solar collector should preferably be combined with TES due to the intermittent feature of solar energy [82]. Most of the studies concluded that the efficiency of an ejector system would be enhanced in a region with sufficient solar radiation but where a low condenser temperature could be maintained. The overall COP of the solar ejector refrigeration cycle can be expressed as equation (4) [80].

$$COP_{overall} = \eta_{solar_panel} COP_{ejector_chiller} \quad (4)$$

Therefore, the solar collector determines the solar-powered system's performance and cooling capability. Advanced refrigeration systems can be developed by completely removing the mechanical pump to realize heat-driven refrigeration systems [84]. Nguyen et al. [85] studied the possibility to use gravitational force to transfer the refrigerant from the condenser to the generator. Shen et al. [86] proposed replacing the mechanical pump with a gas-liquid ejector. Removing completely the mechanical pump would also ensure the resilience of the system as it would not be affected by power outages. Regarding the resilience to heatwaves, the system is dependent on the variability of the conditions at the condenser. The condenser temperature should be kept low enough to ensure system performance.

Due to their rather low EER, ejector refrigeration cycles are not competitive on the market yet due to high costs compared to absorption chillers. Ejector refrigeration systems may become a competitive technology only with higher EERs, which would lead to a reduction of heat exchanger size, hence decreased costs. The main advantages of this refrigeration system are robust operation, low cost and environmental safety [87]. So far, the TRL of ejector systems is 3 [88].

4.2.3. Desiccant systems

Desiccant cooling systems are heat-driven systems that can be used alternatively to conventional VC and sorption cooling systems. They can handle sensible and latent heat loads independently. A desiccant is a substance, either solid or liquid, which absorbs water molecules from warm humid air. The desiccant is later regenerated by heating so that it releases the absorbed moisture [89].

The underlying principle of desiccant cooling systems is to handle latent and sensible loads separately for more efficiency. The latent load of the process air (i.e., moisture) is removed in a dehumidifier that contains a desiccant material. Then, the sensible load can be handled by heat exchangers, evaporative coolers or cooling coils, in which the temperature of the dried process air is decreased to the desired comfort conditions [90]. For the system to work continuously, the desiccant should be regenerated using a heat supply. The regeneration process only requires low-grade heat at about 60–95 °C. Therefore, waste heat from traditional fossil-fuel systems and renewable energies like solar and geothermal heat are potential energy sources for regeneration. However, the desiccant system can also be coupled with an auxiliary heat source such as electricity or a gas heater if the continuous operation of the system is to be ensured [91]. The schematic diagram of the

desiccant system is shown in Fig. 10. If necessary, the air is further cooled in an evaporative air cooler (aftercooler), before being directed into the room.

The system is simple and generally has a satisfactory thermal coefficient of performance. Sahlot & Riffat [92] showed that liquid desiccant systems and solar-assisted desiccant cooling systems have EERs in the range of 0.47–1.38 in different regions [93–96]. Liquid desiccant systems can be used in conjunction with direct or indirect evaporative cooling systems or conventional VC systems since they are suited for latent heat extraction but not sensible heat [97]. Liquid desiccant systems can also be coupled with VC systems, offering the possibility to control temperature and humidity independently. Peña et al. [98] showed that such a system can reach an EER of 4.6. A novel design of a hybrid system of VC system and liquid desiccant system was proposed by She et al. [99]. In this system, the desiccant solution is regenerated using the condensing heat of the VC system. Generally, hybrid VC refrigeration systems show significantly higher EER than conventional VC refrigeration systems. The COP could be increased by up to 18%. Romero-Lara et al. [100] established a comparison between three air-cooling systems in which it appears that desiccant cooling systems consume from three to fifteen times less energy than a conventional VC system depending on the climate zone. Regarding environmental impact, they concluded that desiccant systems could be an alternative to traditional VC systems to reduce CO₂ emissions by 68–78% in the warmest zones.

Desiccant cooling systems are very flexible to energy sources. Since only low-temperature heat is required, the desiccant system can be coupled with a solar system or a geothermal system or by recycling the waste heat from another process. The heat production system can be combined with thermal storage to adapt to the building's needs without requiring the use of a gas heater or electricity [101].

They are not very robust to climate change since their efficiency strongly depends on outdoor air conditions. Moreover, the system requires electricity to drive the fans and pumps, meaning that it is not resilient in case of a power outage. Resilience could be improved by connecting the desiccant cooling system to a microgrid in which electricity is produced by solar panels.

Desiccator wheels are mainly used in non-residential applications, also they can also be used in residential buildings. However, the existing desiccant systems are generally simple with basic equipment and more advanced systems are not widely implemented yet [63]. Desiccant cooling technology could be categorized in TRL level of 3–4 [102].

a Solid desiccant system

In solid-assisted desiccant systems, solid desiccant materials are used to remove the air moisture content in the air through the adsorption process. The advantage of solid desiccant systems over liquid ones is the simpler handling of desiccant materials. Solid desiccants are also compact, less subject to corrosion and carryover [102]. However, solid desiccant materials generally have a higher regeneration temperature than liquid desiccants. Research is carried out to lower the regeneration temperature requirement [103].

b Liquid desiccant system

Liquid desiccants have several advantages over solid desiccants. Liquid desiccants are generally associated with lower-pressure drops, which makes them suitable to use with low-temperature regeneration [104]. The liquid desiccant can also be stored when a heat source is not available for regeneration. A liquid desiccant system combined with a VC system can reduce power consumption by 25% and condensation and evaporation areas by 34%, compared with a VC system alone [89].

5. Comparison between different active cooling systems

Table 2
Qualitative comparison between active cooling systems based on the assessment criteria.

Performance measures		AC Systems																			
		Electricity- Driven AC units (VC)													Thermal Energy-Driven AC Units						
		Producing cold air								Producing chilled water (Chillers)					Sorptions Chiller		Ejector	Desiccant Systems			
		Split systems				Packaged Units				Air-cooled chillers	Water-cooled chillers				Evaporative cooled chillers	Adsorption Chiller		Absorption Chiller	Liquid Desiccant	Solid Desiccant	
		Mono-split systems		Multi-split systems		VRF		Window Unit	Portable Unit		Rooftop Unit	Dry cooler	Wet cooling tower	Geothermal borehole			ATES				
		Ducted systems	Ductless systems	Ducted systems	Ductless systems	2-pipe system	3-pipe system														
Technical details	REV ¹	✓	✓	✓	✓	✓	✓	✓	✓	✓	✓	✗	✗	✓	✓	✗	✓	✓	✗	✗	✗
	REC ²	✗	✗	✗	✗	✗	✓	✗	✗	✗	✗	✓	✓	✓	✓	✗	✓	✓	✓	✗	✗
	PAS ³	✗	✗	✗	✗	✗	✗	✗	✗	✗	✗	✓	✓	✓	✓	✗	✗	✗	✗	✗	✗
	System capacity range	Large	Large	Large	Large	Large	Large	Low	Medium	Large	Large	Large	Large	Large	Large	Large	Large	Large	Large	Low	Large
Assessment Criteria																					
Energy performance	System Efficiency	High	High	High	High	High	High	High	High	High	High	High	High	High	High	High	Low	Low	Low	High	High
Flexibility of the system	Energy source flexibility	Medium	Medium	Medium	Medium	Low	Low	Low	Low	Low	Medium	Medium	Medium	Medium	Medium	Medium	High	High	High	High	High
	Integration with secondary systems	Medium	Medium	Medium	Medium	Medium	Medium	Low	Low	Medium	High	High	High	High	High	High	Low	Low	High	High	High
Climate resilience	Heatwaves	High	High	High	High	Medium	Medium	Low	Low	High	Medium	Medium	High	High	High	High	Medium	Medium	Medium	Low	Low
	Power outages	Low	Low	Low	Low	Low	Low	Low	Low	Low	Low	Medium	Medium	Medium	Medium	Low	Medium	Medium	High	Medium	Medium
Other	Building type	All types	All types	All types	All types	Larger buildings	Larger buildings	Residential	All types	Large buildings	All types	All types	Large office buildings	All types	Large office buildings	All types	All types	All types	All types	All types	All types
	TRL	9	9	9	9	9	9	9	9	9	9	9	9	9	9	9	3-9	3-9	3	3-4	3-4

¹REV: Possibility to reverse the machine to work as a heat pump.
²REC: Possibility to recover heat at condenser (simultaneous heating and cooling).
³PAS: Possibility to make passive cooling.

6. Discussion

6.1. Findings and recommendations

According to the sixth assessment report of the Intergovernmental Panel on Climate Change (IPCC) [105], recurring heatwaves are becoming increasingly frequent. At the same time, buildings should be equipped with resilient cooling technologies to tackle the upcoming heatwaves. In this paper, ACs are classified into two main categories (electricity-driven and thermal energy-driven) cooling systems, with an overall assessment of 20 cooling systems as shown in Fig. 2. Electricity-driven systems are classified into systems producing cold air (split systems and packaged units) and systems producing cold water (air-cooled, water-cooled, and evaporative-cooled) chillers. Thermal energy-driven systems are classified into sorption systems, ejector cooling systems and desiccant systems. As shown in Fig. 1, cooling systems are qualitatively assessed through five assessment criteria (energy performance, flexibility to energy source and secondary systems, climate resilience to heatwaves and power outages, as well as building typology, and TRL). Furthermore, the prospect of reversing the machine to operate as a heat pump, recovering heat at the condenser, and operating in passive cooling mode is also studied.

Table 2 summarizes the results, it can be found that most electricity-driven systems can reverse the machine and work as a heat pump to work in heating mode except for the dry cooler and wet cooling tower. While only adsorption and absorption systems from thermal energy-driven systems can be reversed. Most of the systems cannot recover heat at the condenser except for 3-pipe VRF systems, water-cooled chillers, absorption systems, adsorption systems, and ejector cooling systems. Furthermore, air-cooled chillers and water-cooled chillers are the only systems that can work in passive cooling mode. The results also have shown that most of the systems are available in low, medium, and large capacities except for window units and ejector cooling systems that have low capacities, and portable units that have medium capacities. The efficiency for most of the systems is high as mostly all the conventional VC systems are available in the market with high efficiency, as well as; desiccant cooling systems [106,107], while sorption chiller and ejector cooling systems have lower efficiency levels compared to conventional VC systems.

Electricity-driven systems lack high flexibility with different energy sources. Therefore, they have either low or medium grades as shown in Table 2, based on the system flexibility to be driven by PV systems and renewable energy sources. On one hand, thermal energy-driven systems are energy source flexible systems and can be driven by various thermal energy sources as shown for sorption chillers, ejector cooling systems and desiccant systems. On the other hand, not all electricity-driven systems are highly integrated with secondary systems, only chillers are very flexible regarding integration with secondary systems (e.g., FCU and radiant panels). For thermal energy-driven systems, several applications show high flexibility with integration between ejector cooling systems, desiccant systems, and secondary systems which is not the case for sorption cooling systems.

Climate resilience to heatwaves is assessed according to the system's integration with renewable energy sources (specifically PV systems with batteries as well as biomass), and secondary systems. The results show that split systems and chillers are highly resilient to heatwaves, while the other electricity-driven systems are not very robust against heatwaves. In addition, air-cooled chillers and dry coolers are more sensitive to the outdoor temperature, therefore, they are less resilient to heatwaves than water-cooled chillers. The efficiency and capacity of thermal energy-driven systems are highly dependent on the outdoor temperature more than VC systems. Therefore, they are not strongly resilient to heatwaves, while for sorption systems, a previous study has shown that using a spray-evaporative heat exchanger can reduce the effect of the outdoor temperature on the sorption system capacity [108].

Electricity-driven systems are vulnerable to power outages due to

their dependency on electricity; therefore, they show low resilience to power outages. However, water-cooled chillers can work in passive mode (free chilling/geocooling). Therefore, they are more resilient to power outages than other electricity-driven systems. Sorption systems and desiccant systems have higher resilience grades to power outages compared to electricity-driven systems; due to the small electrical input to run the systems, while ejector cooling systems show high resilient to power outages as an advanced system could be operated without a mechanical pump [84].

Table 2 also shows the building type for the different cooling systems, as well as; their TRL. Most of the systems can be used in all building types except VRF systems, rooftop units, wet cooling towers and ATEs that are used in larger buildings, and window units that can be used in residential buildings only. All the electricity-driven systems are widely available and have a TRL of 9. Thermal energy-driven systems have a lower TRL between 3 and 4 and it could reach 9 in absorption and adsorption systems.

The list below is given as a summary of the main findings and recommendations.

1. Electricity-driven cooling systems are generally more mature technologies than thermal energy-driven cooling systems and they have higher efficiencies. They can also easily be coupled with renewable energy sources such as PV panels. Most electricity-driven systems also exist in reversible modes, such as they can provide cooling in summer and heating in winter.
2. Under some conditions, systems producing chilled water can be used to perform free chilling, leading to a considerable amount of energy saving. Such operating mode largely decreases electricity consumption making it more resilient to power outages.
3. Cooling systems coupled with mechanical ventilation systems grant improving both indoor air quality and energy savings. Generally, they are better suited for newly constructed residential buildings.
4. Thermal energy-driven AC units should be preferentially used in buildings in which some processes induce waste heat. They can also easily be coupled with renewable energy sources, e.g., solar thermal collectors or biomass combustion.

6.2. Strengths and limitations

Through a qualitative approach, this study evaluates the performance of several ACs based on a multi-criteria assessment. This section highlights the strength and limitations that were encountered by using a qualitative approach.

The original strengths of this study are fourfold. First, the performances of the ACs take into account their flexibility to integrate with renewable energy sources and secondary systems. The integration between the different systems is provided in original schematics in this study. Second, the study assesses the possibility of the cooling systems operating, in reverse mode, as a heat pump, the possibility to recover heat at the condenser (simultaneous heating and cooling), and the possibility to operate in passive cooling mode. Third, the study has been conducted on a wide range of technologies, applied to an extended range of cooling capacities and building types. Lastly, this study can be considered a part of the assessment of the different electricity-driven and thermal energy-driven cooling systems; which gives an overview of the most common types on the market.

However, the study has some limitations. First, the amount of literature discussing the resilience of ACs to heatwaves or power outages is rather limited. Generally, research is more focused on studying the performance of ACs under normal operating conditions. However, this uniquely utilises the collection of a large database to evaluate the systems' performances. For each system, the range of EER or COP that is given is resulting from a comparison of more than 30 systems.

The second limitation lies in the comparison between the performances of the different systems. All the systems have not necessarily

been tested using the same boundary conditions or in the same climate, they can also have different capacities for several building types and have different operating conditions. All those parameters make the direct comparison between the systems more complex. Finally, the parameters that have been chosen to compare the ACs are oriented toward climate change mitigation, some other parameters could also have been taken into account to characterize performance measurement that could have advantaged some other systems. In addition, some of the criteria chosen can sometimes be subjective regarding the evaluation (low, moderate or high) and influenced by the comparison with the other systems.

6.3. Future directions

Based on the critical review of the prior studies, a concrete comparison of different cooling systems based on multiple assessment criteria under the same boundary conditions remains challenging. The future directions should be able to consider both challenges and opportunities related to building site and location. For example, it could be an opportunity for one site to provide a water source for heat pumps, while another site has a main gas supply. Another direction should be to the probabilistic changes that are likely to occur in the future with the decision-making process in the different countries, for example, decarbonization of the electrical supply and the energy transitions.

7. Conclusion

This paper provides a qualitative assessment review to classify and assess ACs based on multi-assessment criteria. The study classified the cooling systems based on the energy source into electricity-driven cooling systems and thermal energy-driven cooling systems. The assessment criteria discussed for each cooling technology are the energy performance of the system, the flexibility of the system to energy sources and secondary systems, climate resilience to heatwaves and power outages, and the last parameter is related to the building type and TRL.

The results show that thermal energy-driven systems still lack the technological maturity of electricity-driven systems and are not ready to compete in the market now. Most typical VC systems are available in the market with high efficiency, as well as desiccant cooling systems. While sorption systems and ejector cooling systems have lower efficiency than conventional VC systems. Instead, thermal energy-driven systems are more flexible to be driven by different energy sources, and due to their low electrical input, they are more resilient to power outages. The study also found that only air-cooled and water-cooled chillers are capable of passive cooling operation. Additionally, dry coolers and air-cooled chillers are less resistant to heatwaves than other chillers due to their high sensitivity to outdoor temperatures. The strengths and limitations of the study are concluded in section 6.2 which shows that the paper's strengths rely on discussing the integration with renewable energies and secondary systems including original schematics showing the integration, investigating the reversibility, recovery, and passivity of each system and finally the assessment and comparison for more than 20 cooling systems. However, the study has some limitations due to the fact that limited data sources discuss the resilience of cooling systems to heatwaves and power outages. In addition, the boundary conditions used to discuss each system are not the same in this review, which requires future directions to take into account a quantitative assessment of the same boundary conditions to compare the different systems.

Declaration of competing interest

The authors declare that they have no known competing financial interests or personal relationships that could have appeared to influence the work reported in this paper.

Data availability

No data was used for the research described in the article.

Acknowledgment

This research was partially funded by the Walloon Region under the call 'Actions de Recherche Concertées 2019 (ARC)' (funding number: ARC 19/23-05) and the project OCCuPANT, on the Impacts Of Climate Change on the indoor environmental and energy PerformAnce of buildiNGs in Belgium during summer. The authors would like to gratefully acknowledge the Walloon Region and Liege University for funding. This study is a part of the International Energy Agency (IEA) EBC Annex 80 – "Resilient cooling of buildings" project activities to define resilient cooling in residential buildings.

References

- [1] Climate change 2021: the physical science basis. Contribution of working group I to the sixth assessment report of the intergovernmental panel on climate change. Cambridge University Press; 2021. https://report.ipcc.ch/ar6/wg1/IPCC_AR6_WGI_FullReport.pdf.
- [2] Eyring V, Bony S, Meehl GA, Senior CA, Stevens B, Stouffer RJ, Taylor KE. Overview of the coupled model intercomparison project phase 6 (CMIP6) experimental design and organization. *Geosci Model Dev (GMD)* 2016;9:1937. <https://doi.org/10.5194/gmd-9-1937-2016>. –1958.
- [3] Okpalike C, Okeke FO, Ezema EC, Oforji PI, Igwe AE. Effects of renovation on ventilation and energy saving in residential building. *Civil Engineering Journal* 2022;7:124–34. <https://doi.org/10.28991/CEJ-SP2021-07-09>.
- [4] Elnagar E, Köhler B. Reduction of the energy demand with passive approaches in multifamily nearly zero-energy buildings under different climate conditions. *Front Energy Res* 2020;8:224. <https://doi.org/10.3389/fenrg.2020.545272>.
- [5] Vakiloroaya V, Samali B, Fakhar A, Pishghadam K. A review of different strategies for HVAC energy saving. *Energy Convers Manag* 2014;77:738–54. <https://doi.org/10.1016/j.enconman.2013.10.023>.
- [6] IEA- International Energy Agency. The Future of Cooling- Opportunities for energy efficient air conditioning. 2018. <https://www.iea.org/reports/th-e-future-of-cooling>.
- [7] Kalkan N, Young EA, Celiktas A. Solar thermal air conditioning technology reducing the footprint of solar thermal air conditioning. *Renew Sustain Energy Rev* 2012;16:6352–83. <https://doi.org/10.1016/j.rser.2012.07.014>.
- [8] Labban O, Chen T, Ghoniem AF, Lienhard JH, Norford LK. Next-generation HVAC: prospects for and limitations of desiccant and membrane-based dehumidification and cooling. *Appl Energy* 2017;200:330–46. <https://doi.org/10.1016/j.apenergy.2017.05.051>.
- [9] Gado MG, Ookawara S, Nada S, El-Sharkawy II. Hybrid sorption-vapor compression cooling systems: a comprehensive overview. *Renew Sustain Energy Rev* 2021;143:110912. <https://doi.org/10.1016/j.rser.2021.110912>.
- [10] Best R, Riveria W. A review of thermal cooling systems. *Appl Therm Eng* 2015;75:1162–75. <https://doi.org/10.1016/j.applthermaleng.2014.08.018>.
- [11] Zhang C, Kazanci OB, Levinson R, Heiselberg P, Olesen BW, Chiesa G, Sodagar B, Ai Z, Selkowitz S, Zinzi M, Mahdavi A, Teufel H, Kolokotroni M, Salvati A, Bozonnet E, Chtioui F, Salagnac P, Rahif R, Attia S, Lemort V, Elnagar E, Breesch H, Sengupta A, Wang LL, Qi D, Stern P, Yoon N, Bogatu D-I, Rupp RF, Arghand T, Javed S, Akander J, Hayati A, Cehlin M, Sayadi S, Forghani S, Zhang H, Arens E, Zhang G. Resilient cooling strategies – a critical review and qualitative assessment. *Energy Build* 2021;251:111312. <https://doi.org/10.1016/j.enbuild.2021.111312>.
- [12] Ding G. Recent developments in simulation techniques for vapour-compression refrigeration systems. *Int J Refrig* 2007;30:1119–33. <https://doi.org/10.1016/j.ijrefrig.2007.02.001>.
- [13] Barbosa JR, Ribeiro GB, de Oliveira PA. A state-of-the-art review of compact vapor compression refrigeration systems and their applications. *Heat Tran Eng* 2012;33:356–74. <https://doi.org/10.1080/01457632.2012.613275>.
- [14] Eicker U, Pietruschka D, Haag M, Schmitt A. Systematic design and analysis of solar thermal cooling systems in different climates. *Renew Energy* 2015;80:827–36. <https://doi.org/10.1016/j.renene.2015.02.019>.
- [15] Allouhi A, Kousksou T, Jamil A, Bruel P, Mourad Y, Zeraouli Y. Solar driven cooling systems: an updated review. *Renew Sustain Energy Rev* 2015;44:159–81. <https://doi.org/10.1016/j.rser.2014.12.014>.
- [16] Eicker U, Pietruschka D, Schmitt A, Haag M. Comparison of photovoltaic and solar thermal cooling systems for office buildings in different climates. *Sol Energy* 2015;118:243–55. <https://doi.org/10.1016/j.solener.2015.05.018>.
- [17] Pezzutto S, Quaglino G, Riviere P, Kranzl L, Novelli A, Zambito A, Wilczynski E. Screening of cooling technologies in Europe: alternatives to vapour compression and possible market developments. *Sustainability* 2022;14:2971. <https://doi.org/10.3390/su14052971>.
- [18] Pezzutto S, Fazeli R, De Felice M, Sparber W. Future development of the air-conditioning market in Europe: an outlook until 2020: future development of the AC market in Europe. *WIREs Energy Environ* 2016;5:649–69. <https://doi.org/10.1002/wene.210>.

- [19] Steven Brown J, Domanski PA. Review of alternative cooling technologies. *Appl Therm Eng* 2014;64:252–62. <https://doi.org/10.1016/j.applthermaleng.2013.12.014>.
- [20] Hughes BR, Chaudhry HN, Ghani SA. A review of sustainable cooling technologies in buildings. *Renew Sustain Energy Rev* 2011;15:3112–20. <https://doi.org/10.1016/j.rser.2011.03.032>.
- [21] Oropeza-Perez I, Østergaard PA. Active and passive cooling methods for dwellings: a review. *Renew Sustain Energy Rev* 2018;82:531–44. <https://doi.org/10.1016/j.rser.2017.09.059>.
- [22] Kojok F, Fardoun F, Younes R, Outbib R. Hybrid cooling systems: a review and an optimized selection scheme. *Renew Sustain Energy Rev* 2016;65:57–80. <https://doi.org/10.1016/j.rser.2016.06.092>.
- [23] Bataineh K, Taamneh Y. Review and recent improvements of solar sorption cooling systems. *Energy Build* 2016;128:22–37. <https://doi.org/10.1016/j.enbuild.2016.06.075>.
- [24] European Union, Commission Delegated Regulation (EU). No 626/2011 of 4 May 2011 supplementing Directive 2010/30/EU of the European Parliament and of the Council with regard to energy labelling of air conditioners. 2011. http://data.europa.eu/eli/reg_del/2011/626/oj.
- [25] Attia S, Levinson R, Ndongo E, Holzer P, Berk Kazanci O, Homaei S, Zhang C, Olesen BW, Qi D, Hamdy M, Heiselberg P. Resilient cooling of buildings to protect against heat waves and power outages: key concepts and definition. *Energy Build* 2021;239:110869. <https://doi.org/10.1016/j.enbuild.2021.110869>.
- [26] World Meteorological Organization. <https://public.wmo.int/en>. [Accessed 17 May 2022]. accessed.
- [27] U.S. Department of Energy. Technology readiness assessment Guide — DOE directives, guidance, and delegations. 2011. <https://www.directives.doe.gov/directives-documents/400-series/0413.3-EGuide-04a>. [Accessed 23 August 2021]. accessed.
- [28] European Commission, Directorate-General for Energy, Pezzutto S, Novelli A, Zambito A, Quaglini G, Miraglio P, Belleri A, Bottecchia L, Gantioler S, Moser D, Riviere P, Etienne A, Stabat P, Berthou T, Kranzl L, Mascherbauer P, Fallahnejad M, Viegand J, Jensen C, Hummel M, Müller A. Cooling technologies overview and market shares. Part 1 of the study “Renewable cooling under the revised Renewable Energy Directive ENER/C1/2018-493. Publications Office of the European Union; 2022. <https://doi.org/10.2833/799633>.
- [29] Roth K, Westphalen D, Brodrick J. Ductless split systems, emerging technologies. 2006.
- [30] Bertagnolio S, Stabat P, Caciolo M, Corgier D. IEA-ECBCS annex 48 - review of heat recovery and heat pumping solutions. 2011. https://www.iea-ecbc.org/Data/publications/EBC_Annex_48_Final_Report_R2.pdf.
- [31] Eurovent Certita Certification SAS. TECHNICAL certification rules of the eurovent certified performance mark, eurovent certita certification sas. Paris: FRANCE; 2021. <https://www.eurovent-certification.com/media/images/af0/164/af0164aac35cae5faadeb6d70abb56325107358.pdf>.
- [32] Takeoka A, Fukuda Y, Suzuki M, Hasunuma M, Sakoguchi E, Tokizaki H, Kouzuma S, Waki M, Ohnishi M, Nakano S, Kuwano Y. Solar-powered air conditioner. *Prog Photovoltaics Res Appl* 1993;1:47–54. <https://doi.org/10.1002/pip.4670010107>.
- [33] Parker DS, Dunlop JP, Center FSE. Solar photovoltaic air conditioning of residential buildings. In: Proceedings of the 1994 summer study on energy efficiency in buildings; 1994. p. 10. <https://stars.library.ucf.edu/fsec/822>.
- [34] Ahmad J, Najam Ul Islam M, Sabir J. Performance evaluation and design considerations for a split air-conditioner with built-in thermal energy storage. *Build Serv Eng Technol* 2019;40:560–75. <https://doi.org/10.1177/0143624418818228>.
- [35] Wang J, Zhang Q, Yu Y. An advanced control of hybrid cooling technology for telecommunication base stations. *Energy Build* 2016;133:172–84. <https://doi.org/10.1016/j.enbuild.2016.08.090>.
- [36] Hajjidavalloo E, Eghtedari H. Performance improvement of air-cooled refrigeration system by using evaporatively cooled air condenser. *Int J Refrig* 2010;33:982–8. <https://doi.org/10.1016/j.ijrefrig.2010.02.001>.
- [37] Abdelaziz O, Shrestha SS, Munk JD, Linkous RL, Goetzler W, Guernsey M, Kassuga T. Alternative refrigerant evaluation for high-ambient-temperature environments: R-22 and R-410a alternatives for mini-split air conditioners, oak ridge national laboratory (ORNL). Building technologies research and integration center. BTRIC; 2015. <https://doi.org/10.2172/1223676>.
- [38] Hernandez AC, Fumo N. A review of variable refrigerant flow HVAC system components for residential application. *Int J Refrig* 2020;110:47–57. <https://doi.org/10.1016/j.ijrefrig.2019.11.005>.
- [39] Adnot J, Rivière P, Marchio D, Holmstrom M, Naeslund J, Saba J, Becirspahic S, Lopes C, Blanco I, Pérez-Lombard L, Ortiz J, Papakonstantinou K, Doukas P, Joppolo C, Casale C, Benke G, Giraud D, Houdant N, Colomines F, Hitchin R. Energy efficiency and certification of central air conditioners. 2003.
- [40] Courtney S. REHVA journal 02/2014 - performance of variable refrigerant flow (VRF) systems. 2014. <https://www.rehva.eu/rehva-journal/chapter/performance-of-variable-refrigerant-flow-vrf-systems>. [Accessed 17 May 2022]. accessed.
- [41] Qian M, Yan D, Hong T, Liu H. Operation and performance of VRF systems: mining a large-scale dataset. *Energy Build* 2021;230:110519. <https://doi.org/10.1016/j.enbuild.2020.110519>.
- [42] Xia J, Winandy E, Georges B, Lebrun J. Testing methodology for VRF systems. In: International refrigeration and air conditioning conference; 2002. <https://docs.lib.purdue.edu/iracc/542>.
- [43] Hundy GF, Trott AR, Welch TC. Chapter 13 - packaged units. In: *Refrigeration and air conditioning*. fourth ed. Butterworth-Heinemann; 2008. p. 168–76.
- [44] Faramarzi R, Coburn B, Sarhadian R, Mitchell S, Pierce R. Performance evaluation of rooftop air conditioning units at high ambient temperatures. 2004. <https://www.semanticscholar.org/paper/Performance-Evaluation-of-Rooftop-Air-Conditioning-Faramarzi-Coburn/b3f097d0114255bd386eefa64fd0de1f3a3cd5fc>. [Accessed 9 May 2022]. accessed.
- [45] Kung F, Deru M, Bonnema E. Evaluation framework and analyses for thermal energy storage integrated with packaged air conditioning. 2013. <https://doi.org/10.2172/1107465>.
- [46] Ananthanarayanan PN. Basic refrigeration and air conditioning. 1997. May 17, 2022. <https://www.bookdepository.com/Basic-Refrigeration-Air-Conditioning-P-N-Anathanarayanan/9780074620083>.
- [47] Vuarnoz D, Niederhäuser E-L, Torregrossa D, Gabioud D. On the necessity to integrate power flexibility in cooling systems. *J Phys: Conf. Ser.* 2019;1346:012009. <https://doi.org/10.1088/1742-6596/1346/1/012009>.
- [48] Rhee KN, Olesen BW, Kim KW. Ten questions about radiant heating and cooling systems. *Build Environ* 2017;112:367–81. <https://doi.org/10.1016/j.buildenv.2016.11.030>.
- [49] Chang CK, Fui SK, Bin NW, Azizan MH. In: Comparison of air-cooled chiller, water-cooled chiller and hybrid evaporative air-cooled chiller in Malaysia - a review. Cumberland, United States: International Journal of Arts & Sciences, International Journal of Arts and Sciences LLC; 2013. p. 337–55. May 17, 2022. <https://www.proquest.com/docview/1419026997/abstract/EADBA6BB32C147B8PQ/1>.
- [50] Wallonie energie SPW. Le Réactif n° 32 - juin 2002 : votre machine frigorifique fonctionne en hiver. Adoptez le free-chilling, n.d. <https://energie.wallonie.be/srvlet/Repository/reactif-n-32.pdf?IDR=477>. [Accessed 5 January 2023].
- [51] Ashwood A, Bharathan D. Hybrid cooling systems for low-temperature geothermal power production. 2011. <https://doi.org/10.2172/1009690>.
- [52] Conradie AE, Kröger DG. Performance evaluation of dry-cooling systems for power plant applications. *Appl Therm Eng* 1996;16:219–32. [https://doi.org/10.1016/1359-4311\(95\)00068-2](https://doi.org/10.1016/1359-4311(95)00068-2).
- [53] Boulay RB, Cerha MJ, Massoudi M. Dry and hybrid condenser cooling design to maximize operating income. In: ASME 2005 power conference. Chicago, Illinois, USA: ASMEEDC; 2005. p. 167–75. <https://doi.org/10.1115/PWR2005-50225>.
- [54] Kröger DG. Air-cooled heat exchangers and cooling towers. 2002. <http://eols.net/Sample-Chapters/C08/E3-10-03-06.pdf>.
- [55] Jensen J-P, Conrad B, Schuetz U, Ullrich FR, Wanning A. Hybrid dry coolers in cooling systems of high energy physics accelerators. In: Proceedings of EPAC. Switzerland: Lucerne; 2004. <https://accelconf.web.cern.ch/e04/PAPERS/WEP LT065.PDF>.
- [56] Asvapoositkul W, Kuansathan M. Comparative evaluation of hybrid (dry/wet) cooling tower performance. *Appl Therm Eng* 2014;71:83–93. <https://doi.org/10.1016/j.applthermaleng.2014.06.023>.
- [57] Leeper SA. Wet cooling towers: rule-of-thumb design and simulation. 1981. <https://doi.org/10.2172/5281927>.
- [58] Sun J, Feng X, Wang Y. Cooling-water system optimisation with a novel two-step sequential method. *Appl Therm Eng* 2015;89:1006–13. <https://doi.org/10.1016/j.applthermaleng.2015.01.012>.
- [59] Bertagnolio S. Evidence-based model calibration for efficient building energy services. ULiège - Université de Liège; 2012. <https://orbi.uliege.be/handle/2268/125650>. [Accessed 22 December 2022]. accessed.
- [60] Pontes RFF, Yamauchi WM, Silva EKG. Analysis of the effect of seasonal climate changes on cooling tower efficiency, and strategies for reducing cooling tower power consumption. *Appl Therm Eng* 2019;161:114148. <https://doi.org/10.1016/j.applthermaleng.2019.114148>.
- [61] Jiang Y, Xie X. Theoretical and testing performance of an innovative indirect evaporative chiller. *Sol Energy* 2010;84:2041–55. <https://doi.org/10.1016/j.solener.2010.09.012>.
- [62] Gehlin S. Borehole thermal energy storage. In: *Advances in ground-source heat pump systems*. Elsevier; 2016. p. 295–327. <https://doi.org/10.1016/B978-0-08-100311-4.00011-X>.
- [63] Reuss M. The use of borehole thermal energy storage systems. In: *Advances in thermal energy storage systems*. Elsevier; 2021. p. 139–71. <https://doi.org/10.1016/B978-0-12-819885-8.00006-1>.
- [64] Diersch H-JG, Bauer D. Analysis, modeling, and simulation of underground thermal energy storage systems. In: *Advances in thermal energy storage systems*. Elsevier; 2021. p. 173–203. <https://doi.org/10.1016/B978-0-12-819885-8.00007-3>.
- [65] Nordell B, Snijders A, Stiles L. The use of aquifers as thermal energy storage (TES) systems. In: *Advances in thermal energy storage systems*. Elsevier; 2015. p. 87–115. <https://doi.org/10.1533/9781782420965.1.87>.
- [66] Youbi-Idrissi M, Macchi-Tejeda H, Fourmaison L, Guilpart J. Numerical model of sprayed air cooled condenser coupled to refrigerating system. *Energy Convers Manag* 2007;48:1943. <https://doi.org/10.1016/j.enconman.2007.01.025>. –1951.
- [67] Yu FW, Chan KT. Improved energy performance of air-cooled chiller system with mist pre-cooling. *Appl Therm Eng* 2011;31:537–44. <https://doi.org/10.1016/j.applthermaleng.2010.10.012>.
- [68] Henning H-M. Solar assisted air conditioning of buildings – an overview. *Appl Therm Eng* 2007;27:1734–49. <https://doi.org/10.1016/j.applthermaleng.2006.07.021>.
- [69] Kuehn A, Ziegler F, Dawoud B, Schossig P, Wielen J, Critoph R. Thermally driven heat pumps for heating and cooling. 2013. <https://d-nb.info/1066160627/34>.
- [70] Román JC, Domínguez RJR, Martínez AR, Parra PS. Thermal analysis of an absorption and adsorption cooling chillers using a modulating tempering valve. *IntechOpen*; 2019. <https://doi.org/10.5772/intechopen.84737>.

- [71] Kuczynska A, Szaflik W. Absorption and adsorption chillers applied to air conditioning systems. *Arch Therm* 2010;31:77–94. <https://doi.org/10.2478/v10173-010-0010-0>.
- [72] Pilatowsky I, Romero RJ, Isaza CA, Gamboa SA, Sebastian PJ, Rivera W. Cogeneration fuel cell-sorption air conditioning systems. London: Springer London; 2011. <https://doi.org/10.1007/978-1-84996-028-1>.
- [73] Nikbakhti R, Wang X, Hussein AK, Iranmanesh A. Absorption cooling systems – review of various techniques for energy performance enhancement. *Alex Eng J* 2020;59:707–38. <https://doi.org/10.1016/j.aej.2020.01.036>.
- [74] Almasri RA, Abu-Hamdeh NH, Esmail KK, Suyambazhahan S. Thermal solar sorption cooling systems - a review of principle, technology, and applications. *Alex Eng J* 2022;61:367–402. <https://doi.org/10.1016/j.aej.2021.06.005>.
- [75] Herold KE, Radermacher R, Klein SA. Absorption chillers and heat pumps. 0 ed. CRC Press; 2016. <https://doi.org/10.1201/b19625>.
- [76] Wolak E. The cooling effect by adsorption-desorption cycles. *E3S Web Conf* 2017;14:01052. <https://doi.org/10.1051/e3sconf/20171401052>.
- [77] Wang J, Yan R, Wang Z, Zhang X, Shi G. Thermal performance analysis of an absorption cooling system based on parabolic trough solar collectors. *Energies* 2018;11:2679. <https://doi.org/10.3390/en1102679>.
- [78] Kim DS, Infante Ferreira CA. Air-cooled LiBr–water absorption chillers for solar air conditioning in extremely hot weathers. *Energy Convers Manag* 2009;50:1018–25. <https://doi.org/10.1016/j.enconman.2008.12.021>.
- [79] Stryi-Hipp G, Dias P, Ivancic A, Mugnier D, Weiss W. Solar heating and cooling technology roadmap. 2014. <https://doi.org/10.13140/2.1.3594.9764>.
- [80] Chen J, Havtun H, Palm B. Investigation of ejectors in refrigeration system: optimum performance evaluation and ejector area ratios perspectives. *Appl Therm Eng* 2014;64:182–91. <https://doi.org/10.1016/j.applthermaleng.2013.12.034>.
- [81] Grazzini G, Milazzo A, Mazzelli F. Ejectors for efficient refrigeration. Cham: Springer International Publishing; 2018. <https://doi.org/10.1007/978-3-319-75244-0>.
- [82] Chen X, Omer S, Worall M, Riffat S. Recent developments in ejector refrigeration technologies. *Renew Sustain Energy Rev* 2013;19:629–51. <https://doi.org/10.1016/j.rser.2012.11.028>.
- [83] Besagni G, Mereu R, Inzoli F. Ejector refrigeration: a comprehensive review. *Renew Sustain Energy Rev* 2016;53:373–407. <https://doi.org/10.1016/j.rser.2015.08.059>.
- [84] Chen J, Jarall S, Havtun H, Palm B. A review on versatile ejector applications in refrigeration systems. *Renew Sustain Energy Rev* 2015;49:67–90. <https://doi.org/10.1016/j.rser.2015.04.073>.
- [85] Nguyen VM, Riffat SB, Doherty PS. Development of a solar-powered passive ejector cooling system. *Appl Therm Eng* 2001;21:157–68. [https://doi.org/10.1016/S1359-4311\(00\)00032-6](https://doi.org/10.1016/S1359-4311(00)00032-6).
- [86] Shen S, Qu X, Zhang B, Riffat S, Gillott M. Study of a gas–liquid ejector and its application to a solar-powered bi-ejector refrigeration system. *Appl Therm Eng* 2005;25:2891–902. <https://doi.org/10.1016/j.applthermaleng.2005.02.012>.
- [87] Milazzo A, Mazzelli F. Future perspectives in ejector refrigeration. *Appl Therm Eng* 2017;121:344–50. <https://doi.org/10.1016/j.applthermaleng.2017.04.088>.
- [88] VHK, ARMINES, Viegand, Maagøe ApS (VM). Wuppertal Institute for climate, environment and energy GmbH, technology roadmap in preparatory/review study on commission regulation (EC) No. 643/2009 with regard to ecodesign requirements for household refrigeration appliances and commission delegated regulation (EU) No. 1060/2010 with regard to energy labelling. <http://www.ecodesign-fridges.eu/>; 2016.
- [89] Srivastava A. Performances studies for desiccant cooling system. In: International research journal of engineering and technology. IRJET; 2016. p. 405–8. <https://www.irjet.net/archives/V3/i4/IRJET-V3I480.pdf>.
- [90] Pesaran AA, Penney TR, Czanderna AW. Desiccant cooling: state-of-the-art assessment. National Renewable Energy Laboratory (U.S.); 1992. <https://digital.library.unt.edu/ark:/67531/metadc1187824/>. [Accessed 8 December 2022].
- [91] Ge TS, Xu JC. Review of solar-powered desiccant cooling systems. In: Advances in solar heating and cooling. Elsevier; 2016. p. 329–79. <https://doi.org/10.1016/B978-0-08-100301-5.00013-8>.
- [92] Sahlot M, Riffat SB. Desiccant cooling systems: a review. *Int J Low Carbon Technol* 2016. <https://doi.org/10.1093/ijlct/ctv032>.
- [93] Baniyounes AM, Liu G, Rasul MG, Khan MMK. Analysis of solar desiccant cooling system for an institutional building in subtropical Queensland, Australia. In: Renewable and sustainable energy reviews. Elsevier; 2012. p. 6423–31. <https://ideas.repec.org/a/eee/rensus/v16y2012i8p6423-6431.html>. [Accessed 9 December 2022].
- [94] Fong KF, Chow TT, Lin Z, Chan LS. Simulation–optimization of solar-assisted desiccant cooling system for subtropical Hong Kong. *Appl Therm Eng* 2010;30:220–8. <https://doi.org/10.1016/j.applthermaleng.2009.08.008>.
- [95] Gommed K, Grossman G. Experimental investigation of a liquid desiccant system for solar cooling and dehumidification. *Sol Energy* 2007;81:131–8. <https://doi.org/10.1016/j.solener.2006.05.006>.
- [96] Crofoot L, Harrison S. Performance evaluation of a liquid desiccant solar air conditioning system. *Energy Proc* 2012;30:542–50. <https://doi.org/10.1016/j.egypro.2012.11.064>.
- [97] Henning H-M, Erpenbeck T, Hindenburg C, Santamaria IS. The potential of solar energy use in desiccant cooling cycles. *Int J Refrig* 2001;24:220–9. [https://doi.org/10.1016/S0140-7007\(00\)00024-4](https://doi.org/10.1016/S0140-7007(00)00024-4).
- [98] Peña X, Alonso L, Diaz de Mendibil A, Prieto J, Gommed K. Hybrid liquid desiccant system design and operation under high latent load conditions in Taiwan. *Int J Refrig* 2019;105:41–9. <https://doi.org/10.1016/j.ijrefrig.2018.11.011>.
- [99] She X, Yin Y, Zhang X. Thermodynamic analysis of a novel energy-efficient refrigeration system subcooled by liquid desiccant dehumidification and evaporation. *Energy Convers Manag* 2014;78:286–96. <https://doi.org/10.1016/j.enconman.2013.10.057>.
- [100] Romero-Lara MJ, Comino F, Ruiz de Adana M. Seasonal analysis comparison of three air-cooling systems in terms of thermal comfort, air quality and energy consumption for school buildings in mediterranean climates. *Energies* 2021;14:4436. <https://doi.org/10.3390/en14154436>.
- [101] Kessling W, Laevemann E, Kapfhammer C. Energy storage for desiccant cooling systems component development. *Sol Energy* 1998;64:209–21. [https://doi.org/10.1016/S0038-092X\(98\)00081-4](https://doi.org/10.1016/S0038-092X(98)00081-4).
- [102] Daou K, Wang R, Xia Z. Desiccant cooling air conditioning: a review. *Renew Sustain Energy Rev* 2006;10:55–77. <https://doi.org/10.1016/j.rser.2004.09.010>.
- [103] Maura R, Shrivastava N, Shrivastava V. Performance and analysis of an evaporative cooling system: a review. In: International journal of scientific & engineering research; 2014. <https://www.ijser.org/researchpaper/Performance-and-Analysis-of-an-Evaporative-cooling-System-A-Review.pdf>.
- [104] Sarbu I, Sebarchievici C. Solar thermal-driven cooling systems. In: Solar heating and cooling systems. Elsevier; 2017. p. 241–313. <https://doi.org/10.1016/B978-0-12-811662-3.00007-4>.
- [105] Seneviratne S, Zhang X, Adnan M, Badi W. Weather and climate extreme events in a changing climate. In: Climate change 2021: the physical science basis. Contribution of working group I to the sixth assessment report of the intergovernmental panel on climate change; 2021. <https://www.ipcc.ch/report/ar6/wg1/chapter/chapter-11/>. [Accessed 19 December 2022].
- [106] Goetzler W, Corporate BTO, Shandross RA, Young JV, Petrichenko O, Ringo DFP, McClive S. Energy savings potential and RD&D opportunities for commercial building HVAC systems. 2017. <https://www.energy.gov/sites/prod/files/2017/12/f46/bto-DOE-Comm-HVAC-Report-12-21-17.pdf>.
- [107] Goetzler W, Zogg R, Young J, Johnson C. Alternatives to vapor-compression HVAC technology. ASHRAE J 2014;12–23. <https://iifir.org/en/fridoc/alternatives-to-vapor-compression-hvac-technology-138055>.
- [108] Grzebielec A, Laskowski R, Ruciński A. Influence of outside temperature on the operation of the adsorption chiller. In: Proceedings of 10th international conference “environmental engineering,” VGTU technika. Lithuania: Vilnius Gediminas Technical University; 2017. <https://doi.org/10.3846/enviro.2017.255>.