

Coalescence Modelling for Settler Design

David Leleu, Andreas Pfennig

dleleu@uliege.be

Products, Environment, and Processes (PEPs)

Department of Chemical Engineering

Université de Liège

www.chemeng.uliege.be/Pfennig

agenda

- motivation
- basic understanding
- coalescence modelling
- settler simulation

gravity settler



pilot-plant settler with internals



stirring cell



settling of dispersion

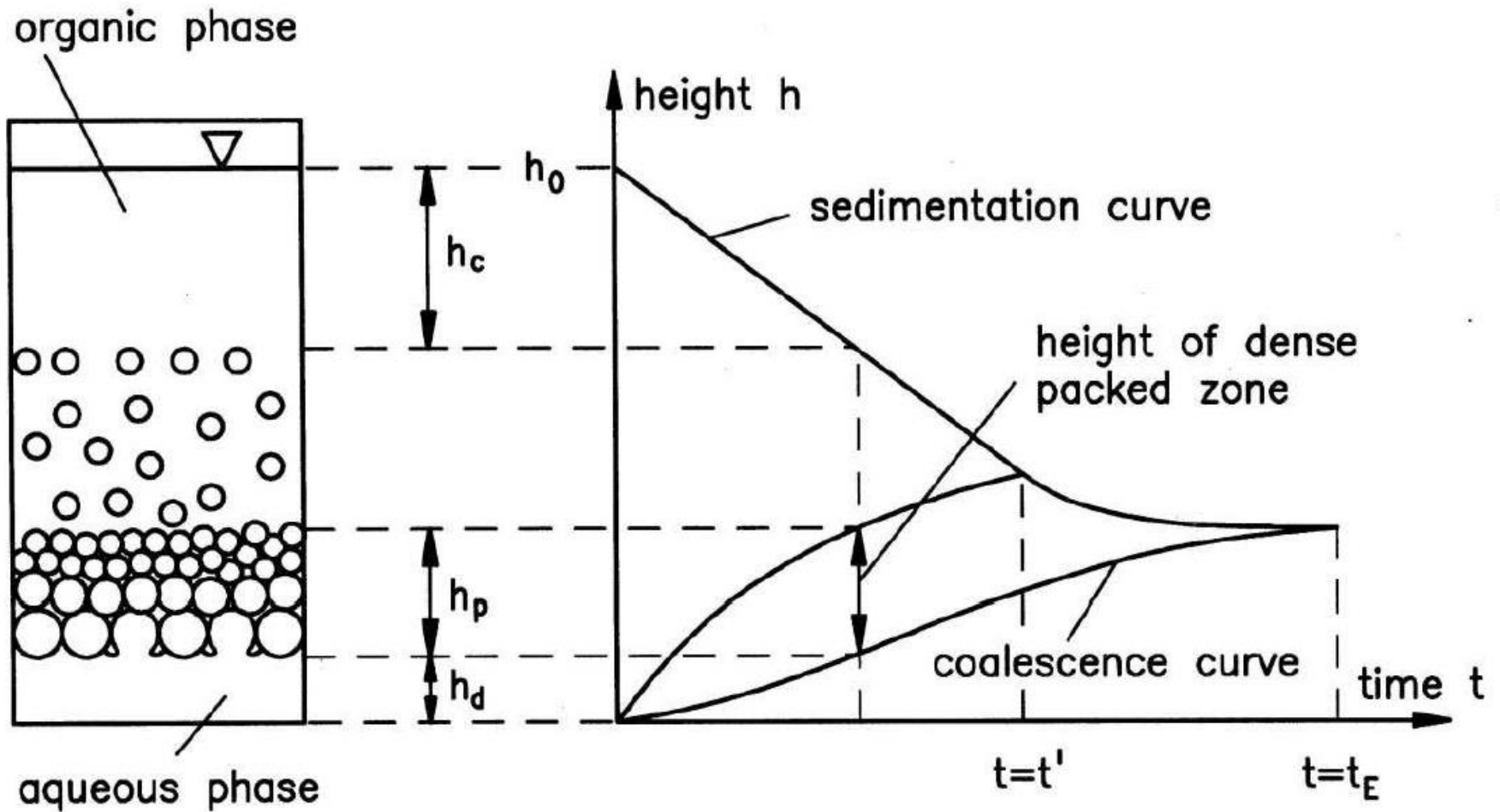

Henschke, 2002

stirring-cell experiment

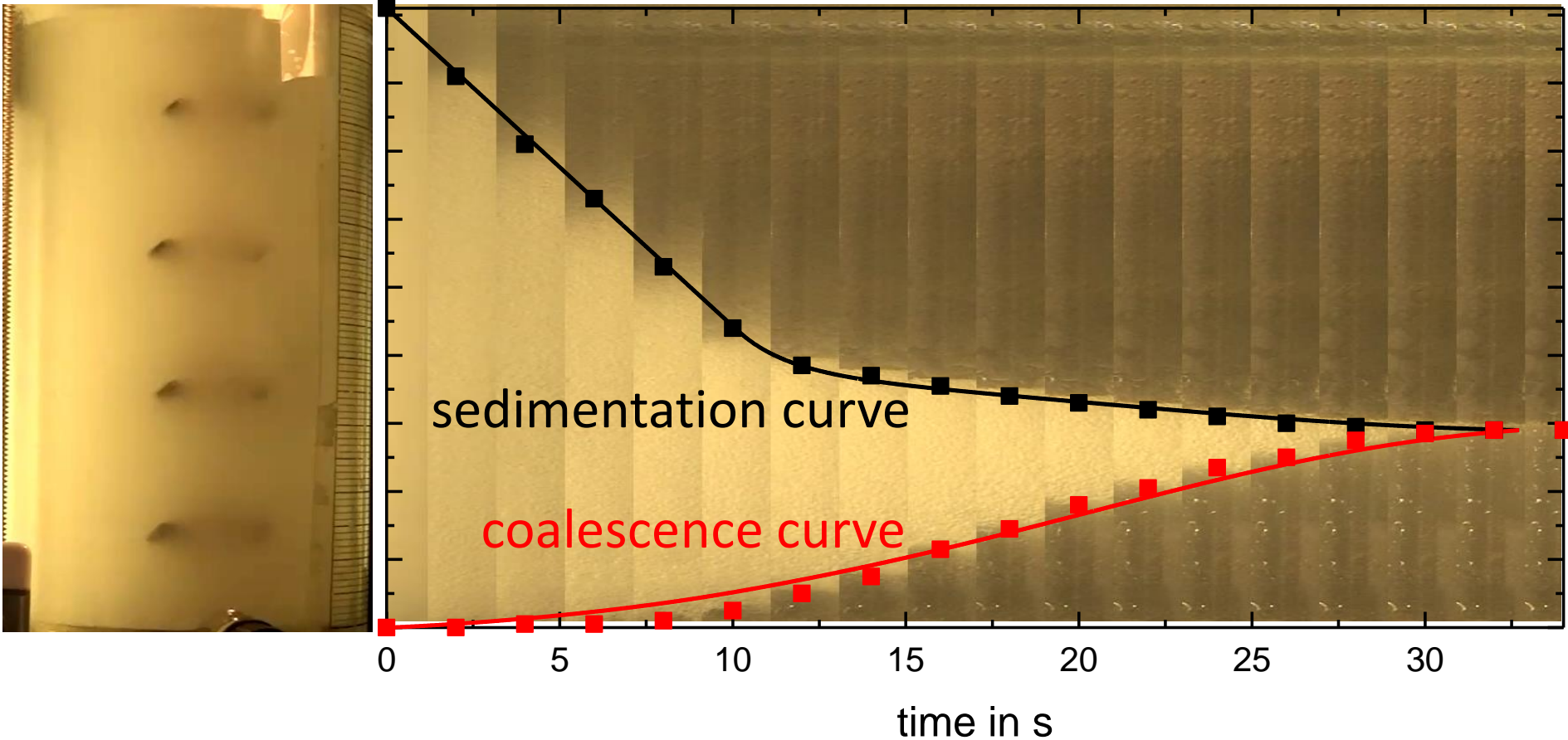

modelling coalescence of drops

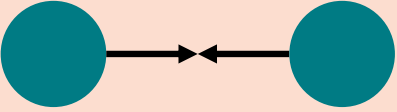
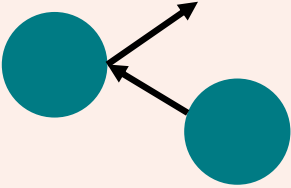
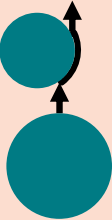
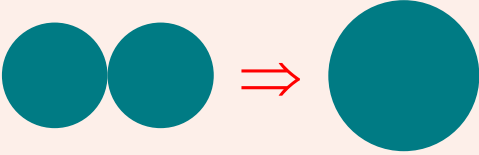
effect	description	influenced by
	frequency at which drops meet	equipment type, fluid dynamics, holdup
	drops bounce at high relative velocity	equipment type, fluid dynamics, operating conditions
	time drops stay in contact, t_{contact}	equipment type, fluid dynamics, operating conditions
	characteristic time drops need to coalesce, $t_{\text{coalescence}}$	material system, drop size

settling of dispersion

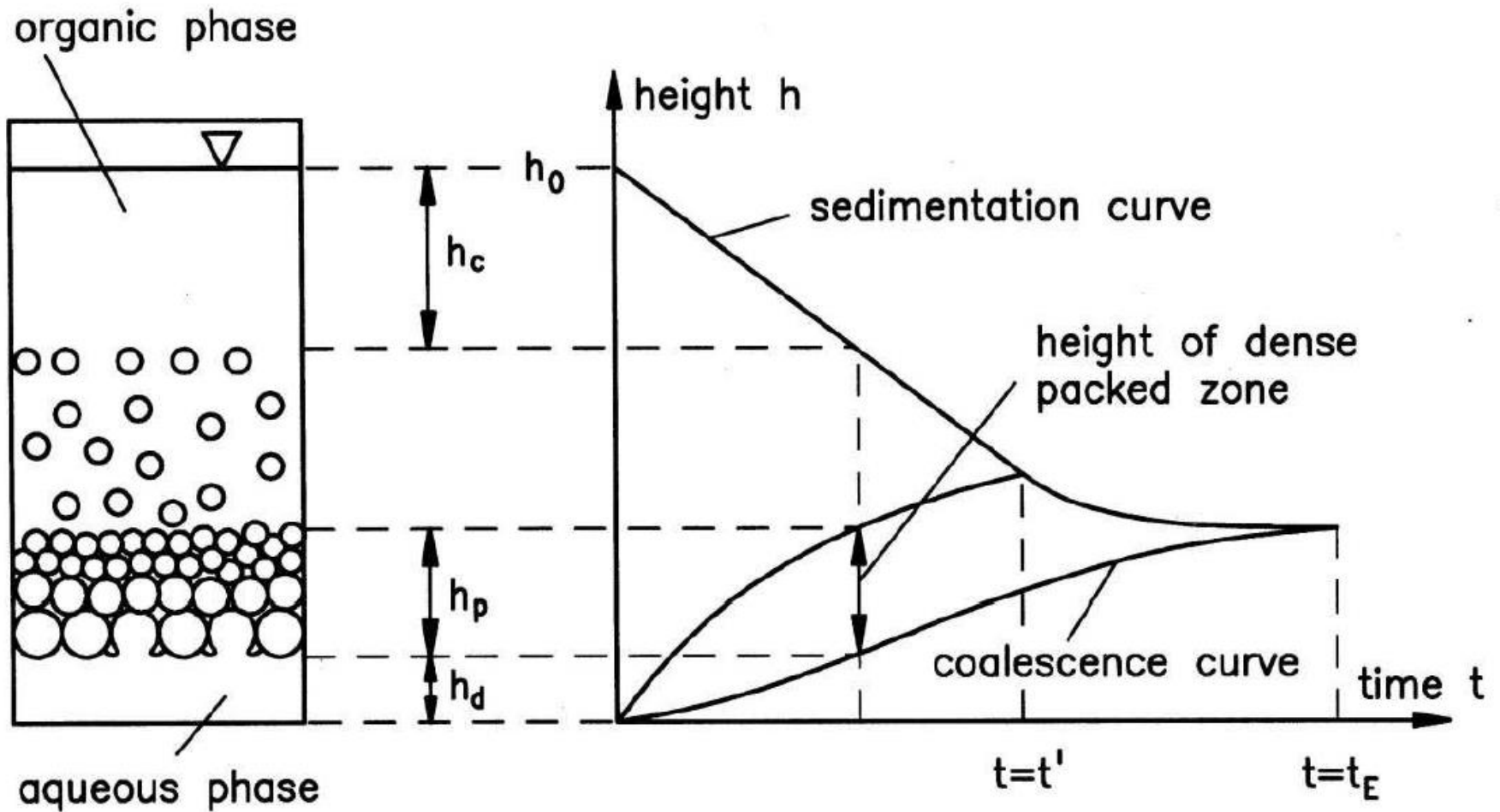

Henschke, 2002

close-packed zone

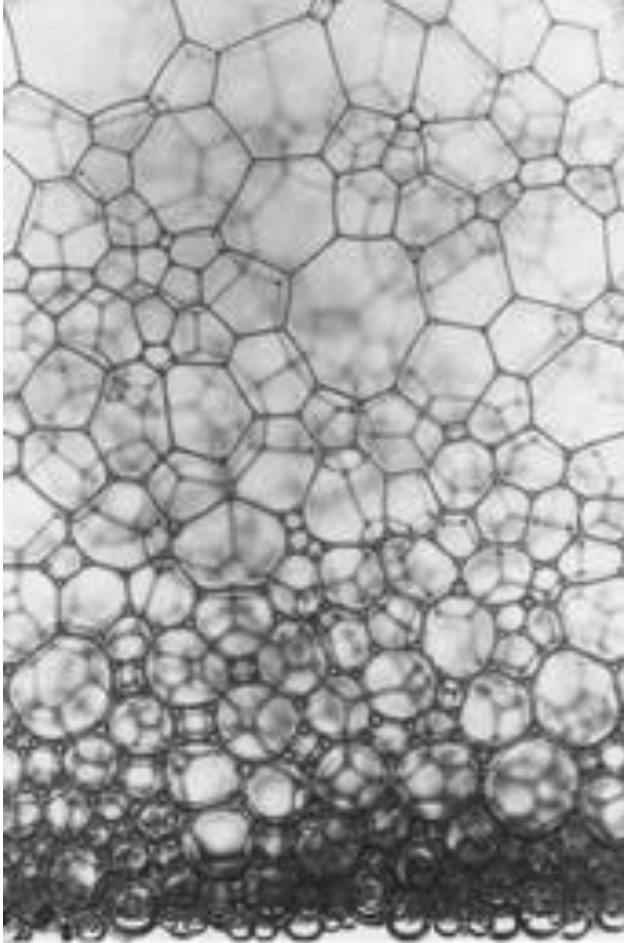

Arnaud Saint-Jalmes, 2006

- drops deformation
- film drainage

counterflow

continuous flow

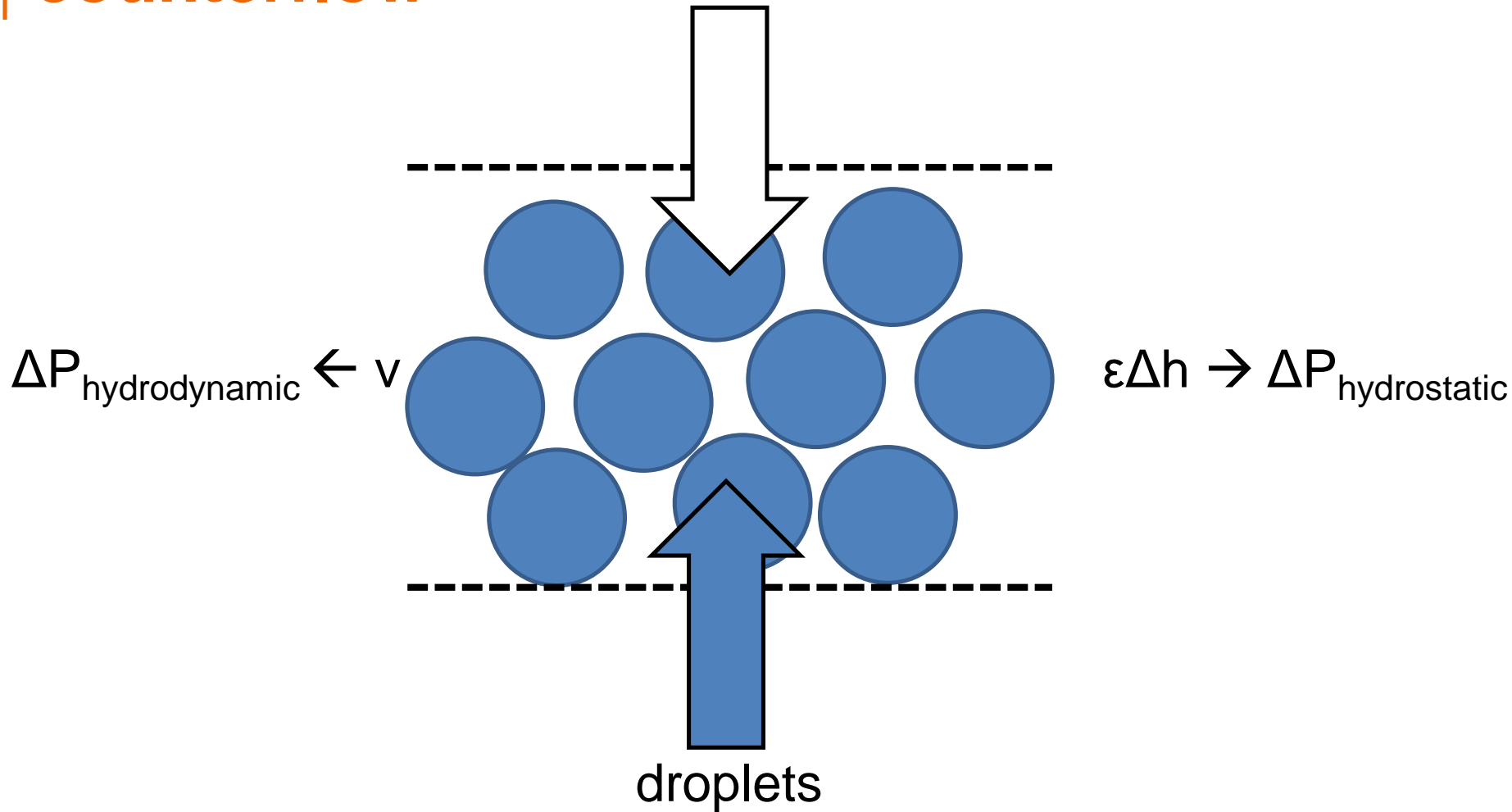

$$\Delta P_{\text{total}} = \Delta p_{\text{hydrostatic}} - \Delta P_{\text{hydrodynamic}}$$

ReDrop (Representative Drop) simulation

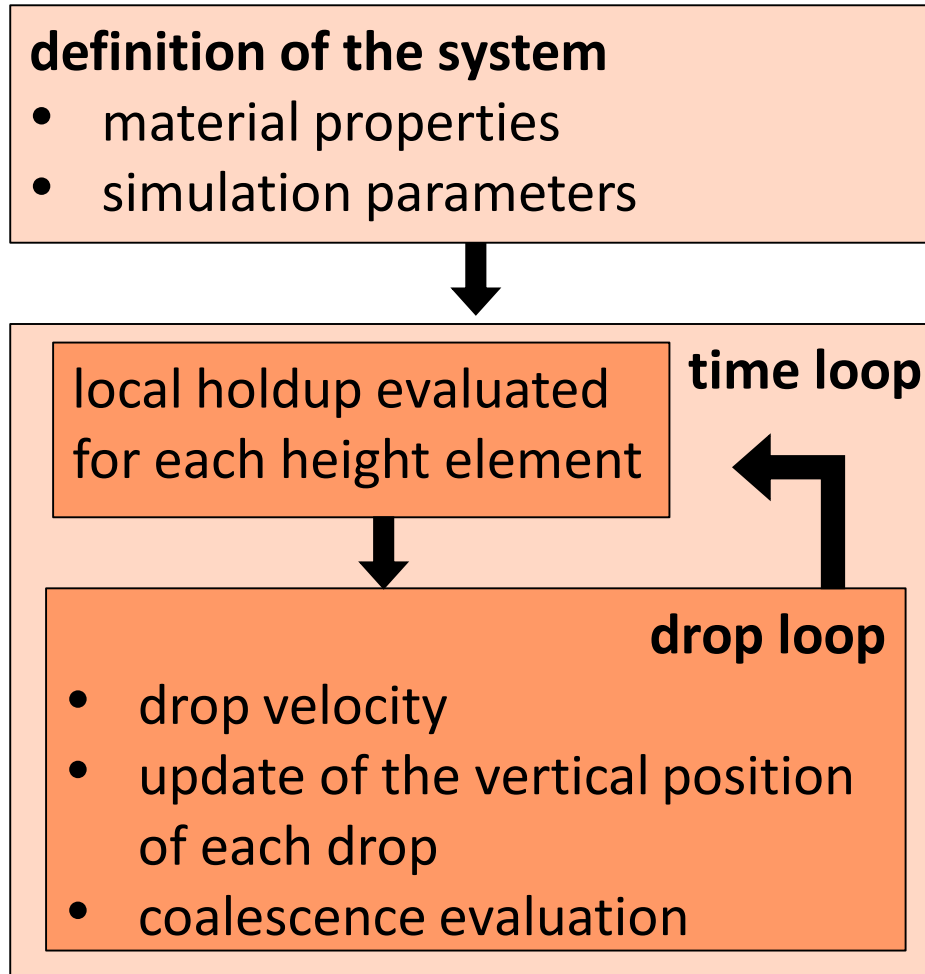

iso-optical settling experiment

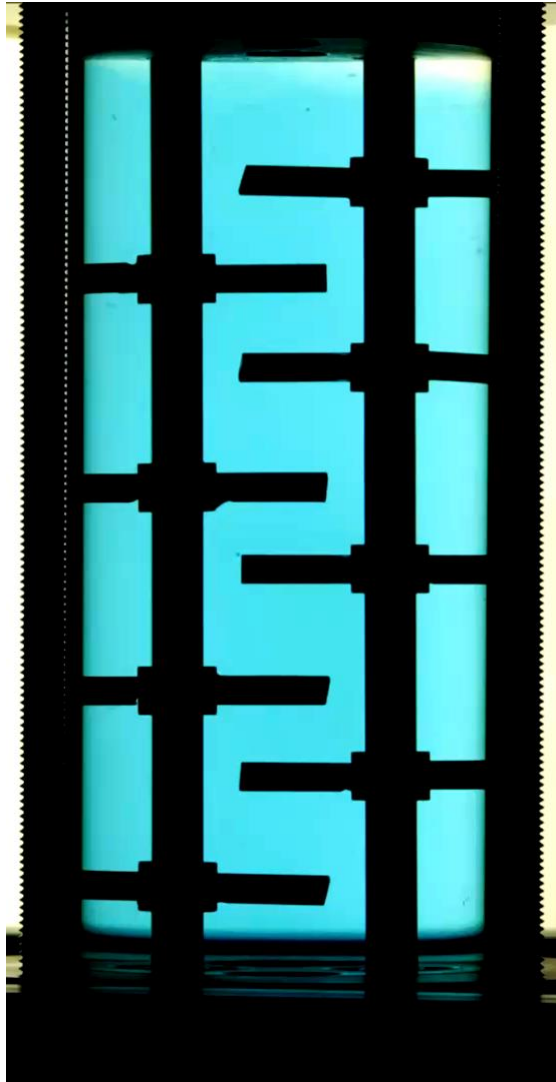

experimental measurement of the holdup

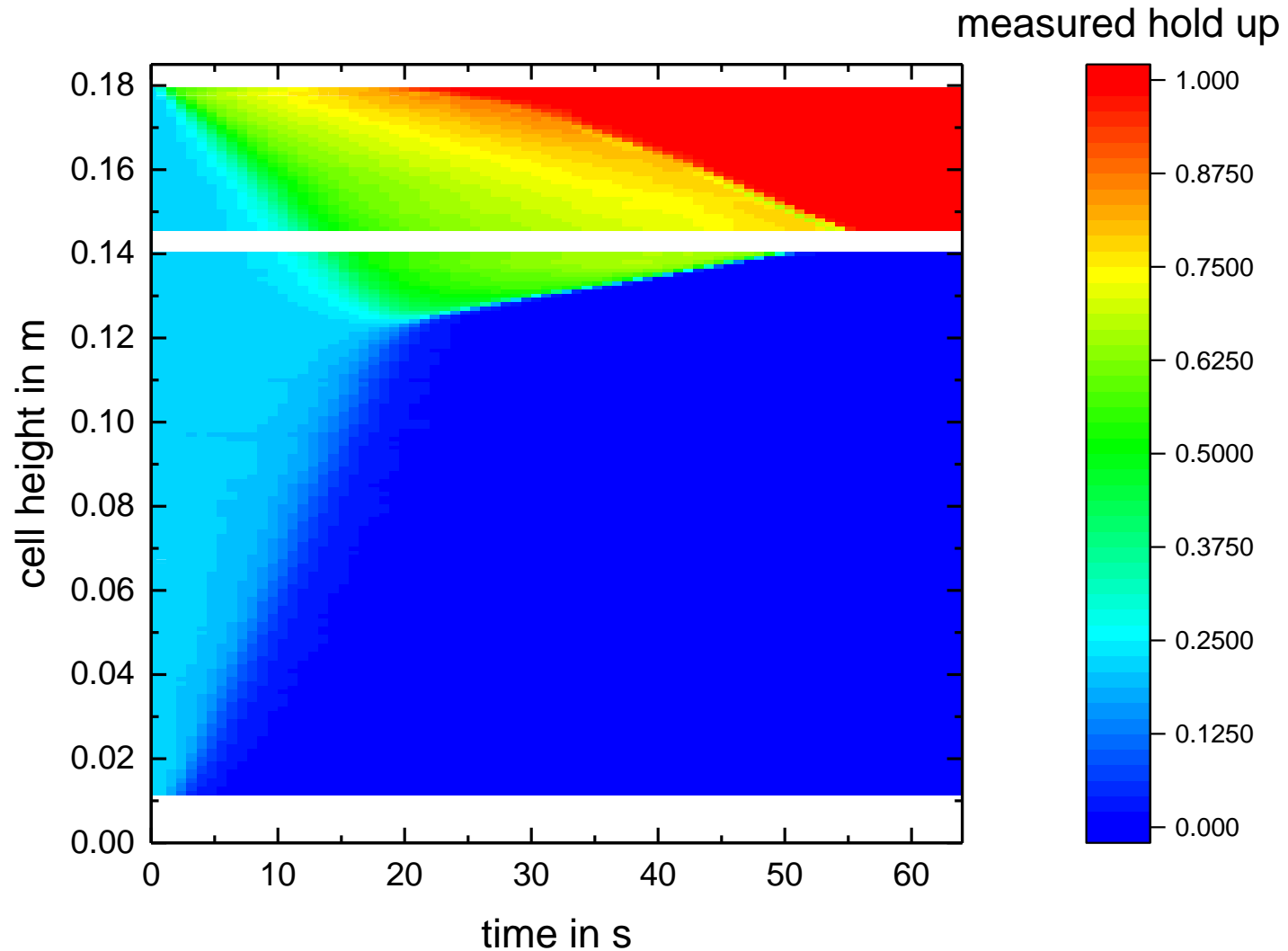

settling simulation

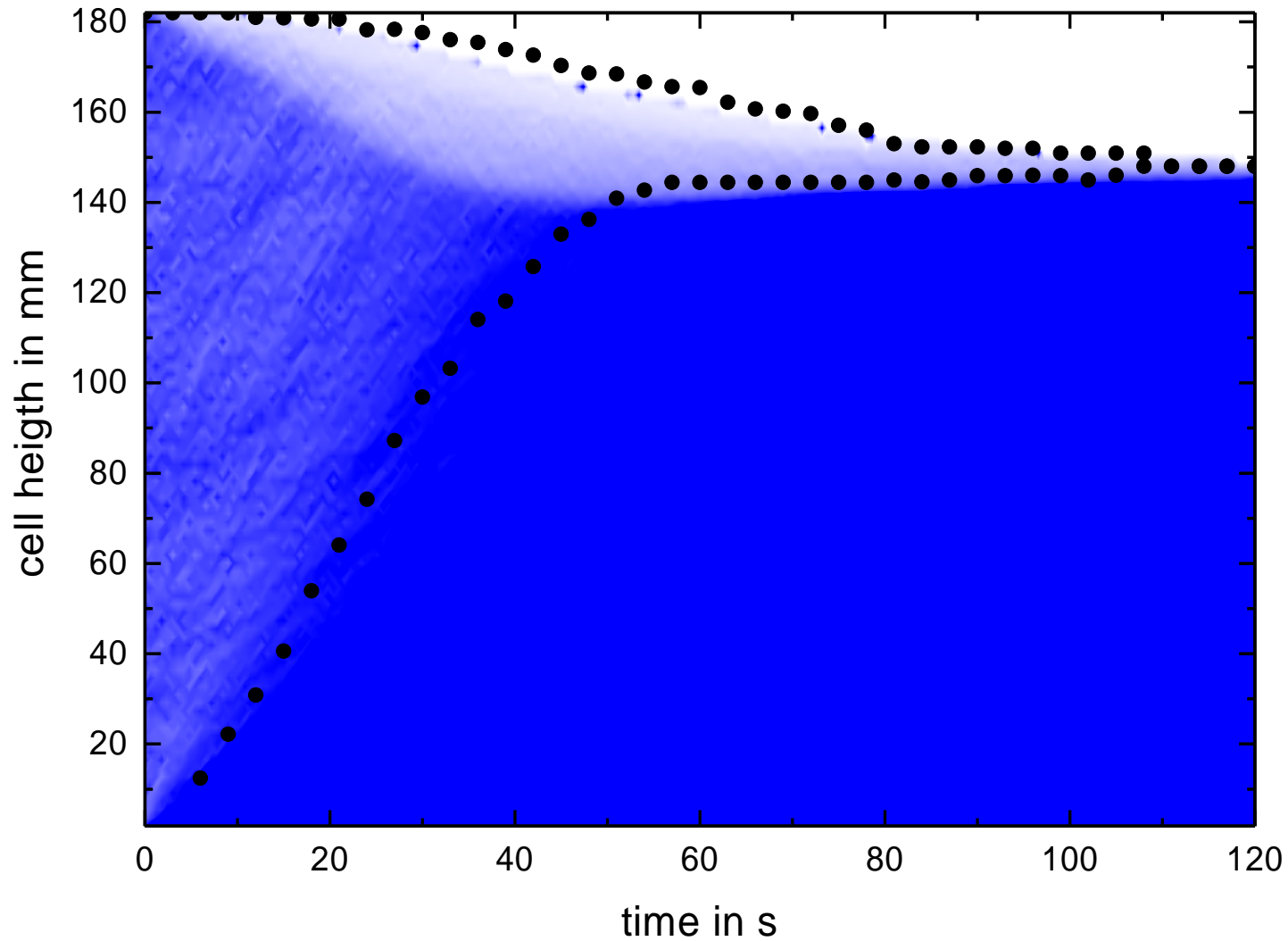

summary

- consistent coalescence model
- calibrated setup for model validation
- simulation tool based on ReDrop
- model able to characterize settling behavior for any system

Coalescence Modelling for Settler Design

David Leleu, Andreas Pfennig

dleleu@uliege.be

Products, Environment, and Processes (PEPs)

Department of Chemical Engineering

Université de Liège

www.chemeng.uliege.be/Pfennig

coalescence probability: fundamental

$$p_{\text{coalescence, Coualoglou\&Tavlarides}} = \exp\left(-\frac{t_{\text{coalescence}}}{t_{\text{contact}}}\right)$$

coalescence probability: fundamental

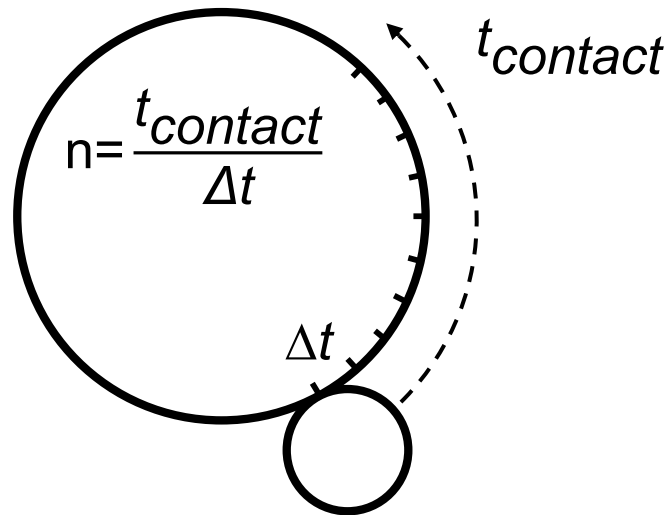

$$\rho_{\text{non-coal}, n\Delta t} = \rho_{\text{non-coal}, \Delta t}^n$$

$$\rho_{\text{non-coal}, \Delta t} = \exp\left(-\frac{\Delta t}{t_{\text{coal}}}\right)$$

$$\rho_{\text{non-coal}, n\Delta t} = \exp\left(-\frac{n\Delta t}{t_{\text{coal}}}\right)$$

$$\rho_{\text{non-coal}} = \exp\left(-\frac{t_{\text{contact}}}{t_{\text{coal}}}\right)$$

$$\rho_{\text{coal}} = 1 - \exp\left(-\frac{t_{\text{contact}}}{t_{\text{coal}}}\right)$$