

Lingopti project: Semi-Continuous Casting Process of Copper-Nickel Alloys

E.Pecquet¹, F.Pascon¹, J.Lecomte-Beckers², A-M.Habraken¹

University of Liège, ¹Department M&S, ²Service MMS

Chemin des Chevreuils 1, B-4000 Liège

email: Etienne.Pecquet@ulg.ac.be, F.Pascon@ulg.ac.be, Jacqueline.Lecomte@ulg.ac.be, Anne.Habraken@ulg.ac.be

Abstract: Lingopti project is a First Europe project. It treats semi-continuous casting of copper-nickel alloys ingots. The research, performed in the University of Liège, consists in the optimisation of the mould and the whole casting process of the LBP S.A. company (Chênee – Liège) to obtain better cast products. In fact, cast products sometimes present long oscillation marks ($\lambda \approx 500\text{mm}$) and some ingots have many internal cracks. The semi-continuous process consists in the vertical casting of 7m height ingots. The goal is also to test different chemical compositions of the material and to predict what happens on the casting process.

Keywords: Casting, copper nickel

I. INTRODUCTION

This research, begun in September 2002, is subdivided into two parts:

- Mechanical and thermal laboratory tests performed to know the behaviour of the material itself but also to determine heat transfer coefficient between the strand and the mould and during whole the casting process;
- Development and validation of finite element models to study, understand and optimise the casting process behaviour.

II. CASTING PROCESS AND MATERIALS

The industrial process of the LBP factory consists in a vertical semi-continuous casting of ingots that are seven meters height. The section of these ingots is 240x870mm. After the mould cooling, there are three other cooling steps: in the air, under water sprays and finally into a water tank.

This process is used to cast copper-nickel alloys. One use of these materials is the fabrication of Euro money. The LBP society uses several alloys; their main component is copper, and the content of Nickel is between some percents to thirty percents. Sometimes, some iron or other components are added. Copper-nickels are high added values materials.

III. LABORATORY TESTS

A. Mechanical Tests

In the casting domain, it is essential to know the mechanical behaviour at high temperatures, up to the liquid state. For high temperatures, the material viscosity also has a big importance. So, compression tests have been carried out at high temperature and at different deformation rates. During a test, the temperature and the strain rate are constant. After, in numerical simulations, the behaviour of the material between two tests conditions is determined by linear interpolation.

Test pieces are cylinders of 13mm diameter and 20mm height. The specimen and a part of the tool are contained into a furnace. First, test temperature must be obtained, it is controlled by a type K thermocouple placed in a small hole, near the surface, at the mid height of the sample. When temperature is stabilised, the compression begin. Figure 1 gives a principle schema of the laboratory machine.

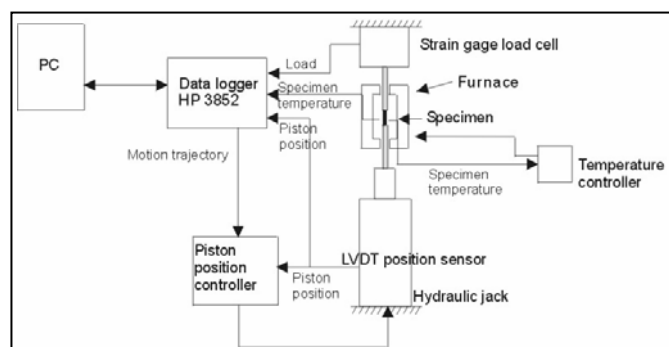

Fig.1. Schema of the machine for hot compression tests

We measure the displacement of the tool and the applied force. Then, we obtain σ - ϵ curves. The strain ϵ is calculated with the following relation:

$$\epsilon = \ln\left(\frac{h_t}{h_0}\right) \quad (1)$$

where h_0 and h_t are respectively the initial and the current height.

Concerning the stress, we know that it isn't exactly a constant on all the mid height section. We have some friction between the sample and the tool, so the sample doesn't conserve an ideal cylindrical form. However for our calculation, the division of the force by the homogenous section gives the stress. This homogenous section correspond to a cylinder that keeps the volume of the initial cylinder.

From the σ - ϵ experimental curves, we calibrate a phenomenological model known as the Norton-Hoff model used in the numerical calculations. The empiric formulation of Norton-Hoff is given by:

$$\sigma = \sqrt{3} \cdot p_2 \cdot e^{-p_1 \cdot \dot{\epsilon}} \cdot \left(\sqrt{3} \cdot \dot{\epsilon}\right)^{p_3} \cdot \epsilon^{p_4} \quad (2)$$

with $\dot{\epsilon} \equiv$ strain rate (constant test by test)

$p_1, p_2, p_3, p_4 \equiv$ material parameters to identify.

The identification of Norton-Hoff material parameters from experiments is carried out by Excel, with the principle of the least squares method. So that, we obtain one set of parameters for each temperature at which tests have been carried out.

Figure 2 gives some examples of Norton-Hoff curves for the alloy Cu Ni 75/25. The influences of the temperature and the strain rate are very important: higher is the temperature and lower is the strain ratio, lower are the stresses.

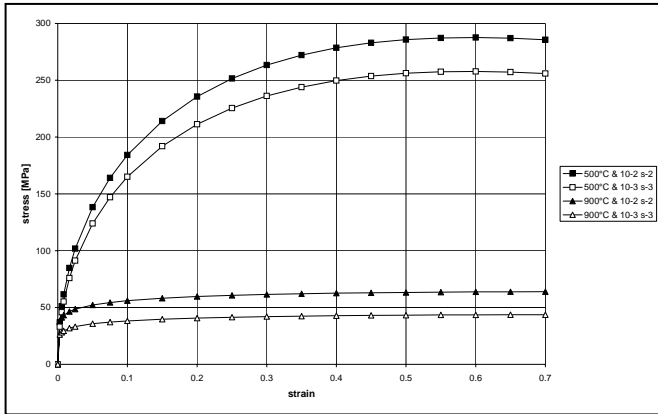

Fig.2. Stress-strain curves of Norton-Hoff for Cu Ni 75/25

Table I gives the material parameters corresponding to the Cu Ni 75/25 studied alloy. In this table, temperatures correspond to those used for the tests. Concerning the deformation rates, we also took three values: 10^{-2} , 10^{-3} , $10^{-4} s^{-1}$. For the identification, each of these rates has the same weight. Test conditions were chosen according to the process we will simulate. For casting, we chose a large range of temperature and very small rates. It is possible to extrapolate a little bit from tests conditions but not too much because there are non linear phenomena.

Concerning numerical calculations with Norton-Hoff model, we make interpolations between tests conditions, both for temperatures and deformation rates.

TABLE I

EMPIRIC NORTON-HOFF PARAMETERS FOR CU NI 75/25.

Température [°C]	P ₁	P ₂	P ₃	P ₄
500	0.794	412.2	0.048	0.470
900	0.135	82.56	0.166	0.110
1100	0.115	43.86	0.239	0.072

B. Thermal Tests

There are two parts in the thermal behaviour: the thermal behaviour of the material itself and the exchanges between the strand and its environment (mould, air, water sprays and water).

Concerning the material behaviour, we determine four parameters C_p , α , ρ and λ , all of them functions of the temperature. The measurement of the specific heat C_p is made with the DSC apparatus (Differential Scanning Calorimetry) coupled with a thermo-gravimetry. The thermal expansion

coefficient α is determined, in all the temperature range, by dilatometric analysis. The specific mass ρ is calculated by taking into account mass and volume variations when the sample is submitted to a program of temperature. The mass variation is measured by thermo-gravimetry (coupled with the DSC analysis) and the volume variation is calculated from results obtained in dilatometry. So, we obtain the specific mass ρ . The diffusivity coefficient $a(T)$ characterises the propagation speed of the heat into the material. It is measured by a Laser Flash. These measurements are taken punctually at different temperatures. The heat conductivity $\lambda(T)$ is calculated from the measurements of the specific heat, the specific mass and the thermal diffusivity, by the relation :

$$\lambda(T)=a(T).\rho(T).C_p(T).100 \quad (3)$$

Figures 3 to 6 give thermal behaviour of the copper-nickel Cu Ni 75/25 : specific heat, specific mass, thermal conductivity and linear dilatation.

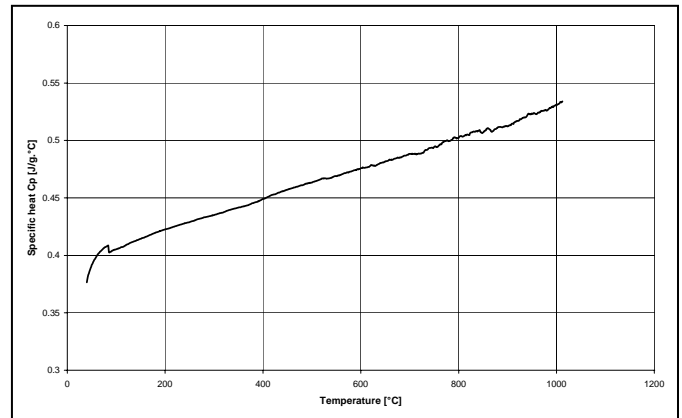

Fig.3. Specific heat of Cu Ni 75/25

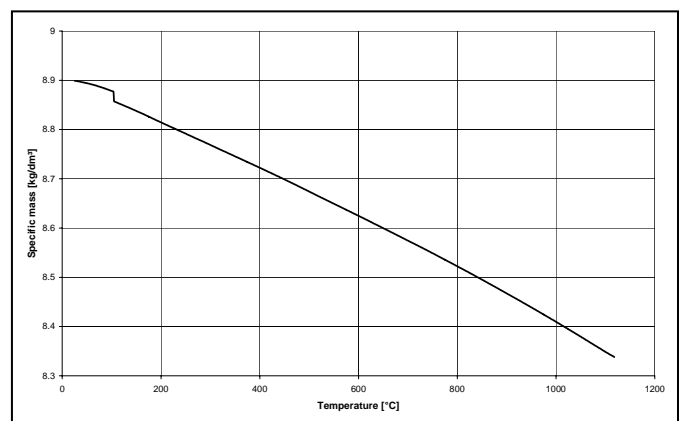

Fig.4. Specific mass of Cu Ni 75/25

On Figure 5, we can see the thermal conductivity of the copper-nickel Cu Ni 75/25 of the LBP industry and another alloy with only 6,05% of Ni (reference [4]). We can see that the thermal conductivity decreases a lot when the percentage of Nickel increases.

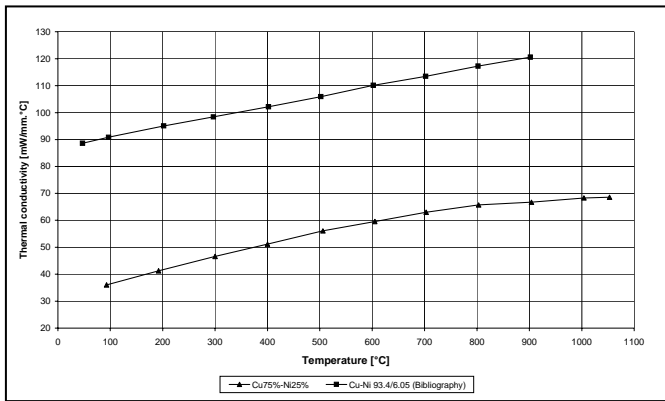

Fig.5. Thermal conductivity of copper-nickel alloys

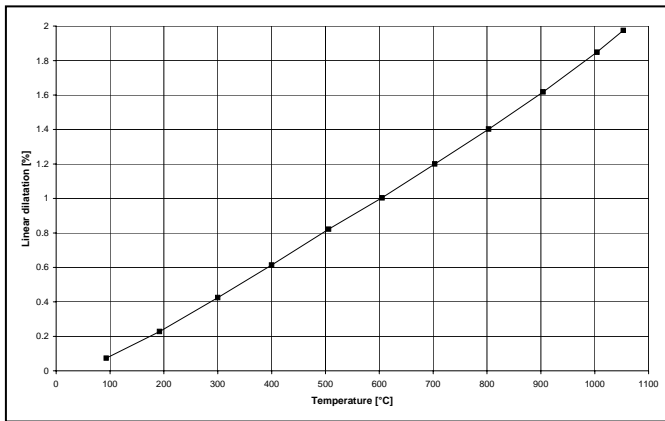

Fig.6. Linear dilatation of Cu Ni 75/25

Above information concerns only the solid state of the material. We are also measuring thermal properties up to the liquid state. At this moment, for the studied Cu Ni 75/25 we have only approximate values:

$$T_{\text{solidus}} \approx 1155^{\circ}\text{C}$$

$$T_{\text{liquidus}} \approx 1243^{\circ}\text{C}$$

$$\text{Latent heat of liquefaction} \approx 200,5 \text{ J/g}$$

Concerning heat transfer coefficients between the strand and the environment, a series of test are currently carried out in the University of Aachen (RWTH), department IBF. We measure, on copper-nickel samples, cooling curves in different conditions, from determined temperatures. For the measurements, we put thermocouples in holes made in the material. After that, by finite elements and inverse analysis, we calculate heat transfer coefficients.

For thermal exchanges with the mould, we will carry out tests with and without contact (because material contacts during the cooling). Different pressures will be tested and a layer of grease between the strand and the mould will be placed, as in the real process. Thus, for these tests, we use a compression machine and specimen are heated with inductors.

For the other coefficients, pieces are heated in a classical furnace with resistances. To prevent the formation of an oxidation layer, argon (inert gas) is pulsed into the furnace. We dispose of a machine with water sprays that has been developed in this research; air cooling is directly done in the

laboratory air and for water cooling, a simple water tank is used, big enough to keep a quite constant temperature.

IV. NUMERICAL CALCULATIONS

For the numerical simulations, we use the finite element Lagamine code, developed at the department M&S of the University of Liège since 1982.

A. Used parameters

Concerning the mechanical aspect, we use the phenomenological approach of the Norton-Hoff curves explained here above.

For the thermal behaviour, we use Fourier law with heat conductivity and an enthalpic heat capacity formulation (easier to take into account of the latent heat of liquefaction).

The contact or non contact is modeled by a Coulomb's law with a penalty method to treat the distance between the strand and the mould. Thermal exchanges differs with these situations of contact or not. Because of the way to perform the tests to determine heat transfer coefficient, convection and radiation are taken into account together with a unique transfer coefficient.

The cuprostatic pressure is also modeled with special finite elements.

Because of we currently don't dispose of the right coefficients corresponding to the copper-nickel casting, following numerical simulations have used approximated heat transfer coefficients, from the experience of the department in the steel domain. So, we took the next constants (independent on the temperature) values:

$$h_{\text{mould}} = 1,45 \text{ mW/mm}^2 \cdot ^{\circ}\text{C}$$

$$h_{\text{air}} = 0,70 \text{ mW/mm}^2 \cdot ^{\circ}\text{C}$$

$$h_{\text{water sprays}} = 2,50 \text{ mW/mm}^2 \cdot ^{\circ}\text{C}$$

$$h_{\text{water}} = 0,80 \text{ mW/mm}^2 \cdot ^{\circ}\text{C}$$

The casting temperature is 1275°C .

Results presented in figures 7 and 8 correspond to first calculations where there isn't any adjustment of coefficients to obtain what is measured in the industry.

B. Numerical simulations

At regard of the size of a real complete ingot, we think that a complete three dimension thermo-mechanical simulation is too hard to carry out. First, we will understand the behaviour of the process. We decided orienting the research on two dimension models.

The first one is a vertical slice we studied in thermal analysis only. The ingot section is $240 \times 870 \text{ mm}$. We think that the heat flow, at least near the centre of the section, is principally oriented along the 240mm. A vertical slice of 240mm and 7metres in height is modeled. This simulation gives a first view of the temperature field. It allows to perform a parametric study to identify parameters which have a great importance. It appears that the first cooling, at the level of the mould, is more important than the secondary cooling (in the air, under water sprays and in the water tank). Another very

important parameter is the good knowledge of the latent heat of liquefaction. Finally, this model gives the ratio between the vertical and the horizontal heat flow. We saw that the vertical heat flow is only the tenth of the horizontal one. This information is very important to validate a modelization of an horizontal slice that does not take into account the vertical exchanges.

Figure 7 gives a view of the result temperature field within this vertical slice. Numbers correspond to the following temperature ranges:

- 1: $1275^{\circ}\text{C} > T > 1180^{\circ}\text{C}$
- 2: $1180^{\circ}\text{C} > T > 1100^{\circ}\text{C}$
- 3: $1100^{\circ}\text{C} > T > 1020^{\circ}\text{C}$
- 4: $1020^{\circ}\text{C} > T > 940^{\circ}\text{C}$
- 5: $940^{\circ}\text{C} > T > 870^{\circ}\text{C}$
- 6: $870^{\circ}\text{C} > T > 790^{\circ}\text{C}$
- 7: $790^{\circ}\text{C} > T > 550^{\circ}\text{C}$
- 8: $550^{\circ}\text{C} > T$

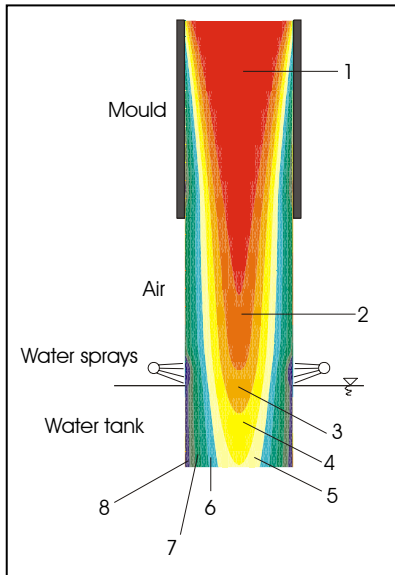

Fig.7. Vertical slice simulation: temperature field

The vertical slice gives only a two dimensions view of the ingot. As the vertical heat flow is small in comparison to the horizontal one, we decided to modelize an horizontal slice. Such a model has already been developed and used by F.Pascon for continuous casting of steel [2]. In this model, we realize thermo-mechanical analysis. The slice is in general plane state. We study the time evolution of this slice. If we put each slice characterised by the time x after the slice of time $x-1$, we obtain a three dimension view that corresponds of an instantaneous view of the real three dimensions continuous process. We name that a 2D1/2 model (and not a 3D) because it doesn't take into account the heat flow in the direction of the casting process or the shear stresses or even detailed axial stresses and it can only give a view in the permanent situation and not at the beginning or at the end of the process. This model, because of this thermo-mechanical behaviour, can reproduce situations of contact and non contact with the mould. We can also see what happens at the corners of the section. This model takes into account, in a

simplified way, stresses in the casting direction [2]. Figure 8 presents an horizontal slice and specially the three states of the material : the liquid, a mushy zone (temperature between T_{solidus} and T_{liquidus}) and the solid state.

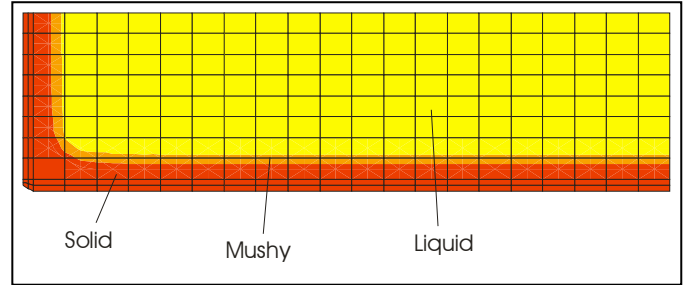

Fig.8. Horizontal slice simulation: material state

For the thermo-mechanical calculations, there are often some problems of convergence due to different numerical behaviour for the mechanic and thermal parts. In fact, mechanic requires small time steps to have good convergence and thermal behaviour requires large increments of time to avoid the problem of the "thermal shock". To solve this incompatibility, the "semi-coupled" strategy has been developed in the Lagamine code. In this method, we perform, in alternation, mechanical and thermal analysis. So we can have different size of time steps for the two parts. At defined points of this procedure, information are transferred between the two types of analysis, as displacements, stress or temperature field. The order we choose to realise the analysis has a non negligible influence on the results. In casting, that's principally the thermal aspects that govern all the phenomena. So, it is better to begin the simulation by a thermal analysis; we have then a better temperature field.

In the near future, we will also develop a third numerical model : a vertical slice studied by thermo-mechanical analysis. At present, in the real process, sometimes, we can see long oscillations ($\lambda \approx 500\text{mm}$) on the largest faces of the ingot. It is difficult to reproduce this problem numerically with the horizontal slice. That's the reason to develop this third model.

V. PERSPECTIVES OF THE RESEARCH

In the next months, tests to determine heat transfer coefficients will continue. It will be examined if the percentage of Nickel has an influence on these coefficients.

Mechanical as well as thermal tests will be carried out on another alloy. The ending goal is to predict what happens on the casting process when it is decided to change the alloy.

One or several thermo-mechanical numerical models should be validated. To realize this point, we will dispose of two different measurements. First, we should find numerically the same deep of the liquid shaft then in the real process. Secondly, the mould is cooled by water displacing around it; the flow of this water is known and also its temperatures of input and output. So, we can calculate a quantity of energy extracted at the level of the mould. This quantity must be the

identical in the numerical simulations. In addition to that, the cooling circuits for the small and the great faces of the mould are separated. So, we dispose of two different values to validate our models.

Another important point is also to reproduce, numerically, problems that the industry has on some castings, as defaults of planarity of the greatest faces of the ingots, long oscillations ($\lambda \approx 500\text{mm}$) on these faces. Crackings can also appears in the cast product, not necessarily at the corners of the section.

Numerical simulations help to verify the quality of the contact, during all the passage in the mould. This information is already an indicator if the mould shape is near or not from the optimum.

Finally, the ultimate goal of this research is the optimisation of the quality of the cast product. For that, as the mould is an important parameter of the process, we will optimise it. It is possible to play on its geometry but also with the quality and the quantity of the mould cooling.

Whole the process will be optimised. It is possible to change conditions of cooling after the mould. Specially, water sprays can be changed (geometry and water flow). The level of the water in the water tank is also variable. And last but not least, we can change the casting speed.

VI. CONCLUSIONS

During the beginning of this research, laboratory tests have already allow to have information about the thermal and mechanical behaviour of copper-nickels at high temperatures. So, we dispose of stress strain curves at different temperatures and deformation rates. Norton-Hoff empiric law has been calibrated on these tests. Concerning the thermal aspects, characteristics λ , ρ and C are already known. Some influences of the content in Nickel on the heat conductivity have been shown.

In the near future, mechanical and thermal (for the materiel itself and also for exchanges coefficients) tests will continue.

Numerical simulations are currently in development. Models will be validated and will allow to understand in details whole the casting process. After that, an optimisation part will be carried out.

ACKNOWLEDGEMENTS

This research is subsidized by the *Walloon region* and the *European Social Fund*. The authors would like to acknowledge these two partners for their financial support.

This research is conducted with the collaboration of the LBP S.A. company. We acknowledge ir. Ph.Nyssen, R&D director of this factory, for his active collaboration.

IBF institute is thanked for its help to measure heat transfer coefficients.

REFERENCES

[1] P. Moureaux, S. Moto Mpong, M. Remy, C. Bouffieux, J. Lecomte-Beckers, AM. Habraken, *Identification d'une loi thermo-élasto-*

- viscoplastique en vue de la modélisation du laminage à chaud du cuivre*, Journal de Physique IV – France, volume 12, Pr 11-361-368.
- [2] F. Pascon, AM. Habraken, *Finite element thermomechanical model of continuous steel casting*, Advanced technology of plasticity, 2002, Volume 2, p.1321 – Japon Society for Technology of Plasticity. Edited by M.Kuichi, H.Nishimura, J.Yanagimoto.
- [3] JF. Charles, AM. Habraken, J. Lecomte, *Modeling of elasto-viscoplastic behaviour of steels at high temperatures*, Simulation of materials processing: theory, methods and applications, NUMIFORM 1998. Huétink, Baaijens editors - Balkema
- [4] A. Goldsmith, T.E. Watermann, H.J. Hirschhorn, *Handbook of Thermophysical Properties of Solid Materials*, The Mc Millan Company, New York, 1961