

OPTIMIZATION OF ROLLING AND FLOATING LOCK GATES

RIGO Philippe
ANAST, University of Liege
FNRS, Belgium
Ph.rigo@ulg.ac.be

PIRCALABU Eugen
ANAST, University of Liege
,Belgium
eugen.pircalabu@ulg.ac.be

AMIROUCHE Amrane
ANAST, University of Liege
Belgium
A.Amrane@ulg.ac.be

CAPRACE Jean David
ANAST, University of Liege
FNRS, Belgium
Jd.caprace@ulg.ac.be

ABSTRACT

This paper presents a methodology to minimize the weight of the gate by optimizing simultaneously the height of the floating tanks, the number of their watertight partitions and the gate scantling while considering the floating stability (Richir et al. 2006)

The rolling gate, considered for this lock, has to float to be led into the port for maintenance or repairing operations. Two partitioned floating tanks are used inside the gate. Water ballast can be pumped from the floating tanks to float the structure or to restore the mass equilibrium in case of damage due to boat impact.

INTRODUCTION

Antwerp is less than 100 km away from the embouchure of the Scheldt River into the North Sea so that the Scheldt River is there still sensitive to the tides. To keep a constant water level inside the Antwerp port, seven shipping locks are used. The Antwerp port authority recently decided to convert one of these shipping locks (the Van Cauwelaert lock) into a dedicated inland navigation lock to improve the traffic between the port and the Scheldt River.

A rolling gate, so-called “wheelbarrow” or “lateral displacement gate”, is considered for this lock (Figure 1). Its dimensions are 36 x 7 x 19 m (length x width x height). Moreover this gate has to float to be led into the port for maintenance or repairing operations. Two partitioned floating tanks are thus used inside the gate. Water ballast can be pumped from the floating tanks to float the structure or to restore the mass equilibrium in case of damage due to boat impact.

The floating stability analysis of the gate is explained in the first part of the paper. The LBR-5 software used to optimize the gate scantling is described in the second part. The third part presents the way to minimize the weight of the gate by optimizing simultaneously the height of the floating tanks, the number of their watertight partitions and the gate scantlings while considering the floating stability.

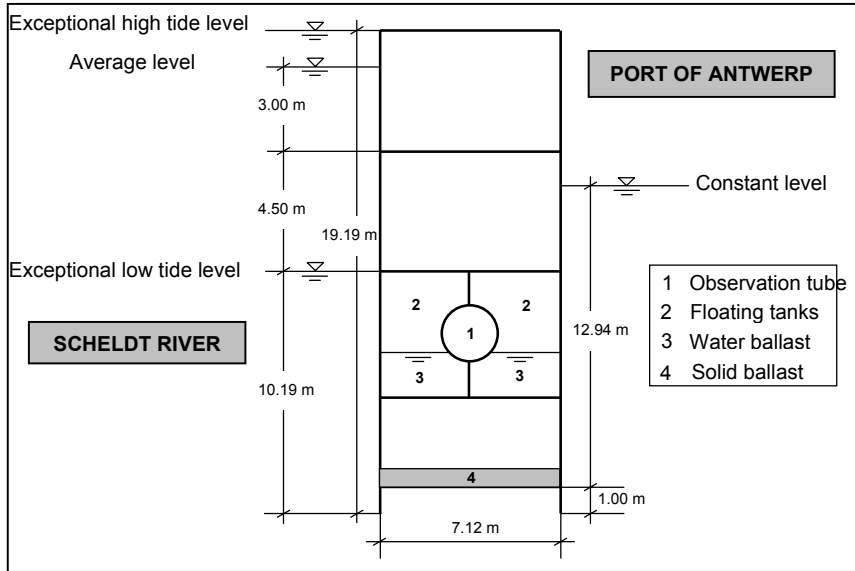

Figure 1: Cross-Section of the Van Cauwelaert Lock Gate

FLOATING STABILITY

The rolling gate considered for the Van Cauwelaert lock has to float to be led into the port for maintenance or repairing operations (Figure 1). Moreover the gate has still to float with a maximum 8 m wide hole in one floating tank caused by a boat impact.

WATER BALLAST

Two partitioned floating tanks are filled partially with water ballast which can be pumped out to float the structure and to restore the mass equilibrium in case of damage. The minimum height of water ballast is thus given by Figure 2 and Equations 1 to 4:

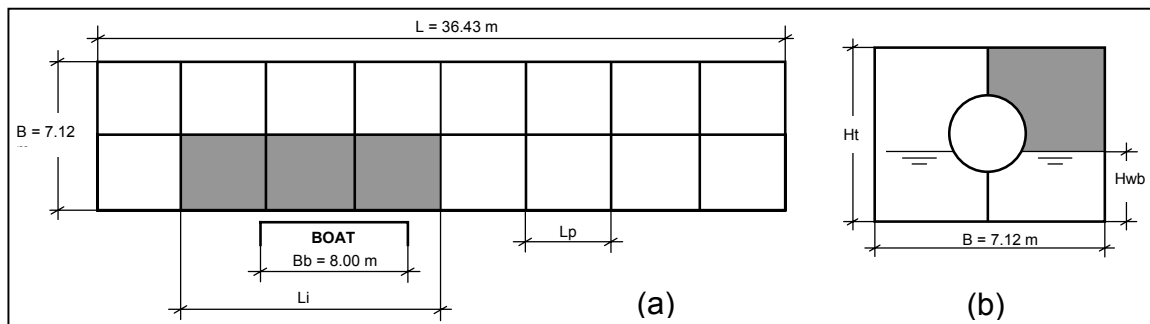

Figure 2: Example for Damaged Floating Tanks

(a) Plan View (b) Cross-Section

Volume of income water:

$$V_i = B/2 \times (H_t - H_{wb}) \times L_i \quad [1]$$

Volume of water ballast to pump out:

$$V_o = B/2 \times H_{wb} \times (L - L_i) \quad [2]$$

Water ballast height ([1] = [2]):

$$H_{wb} = H_t \times L_i / L \quad [3]$$

Length of income water:

$$L_i = \{\text{roundup}(B_b / L_p) + 1\} \times L_p \quad [4]$$

With L_p distance between two transverse watertight partitions

H_t height of the floating tanks

SOLID BALLAST

The floating stability is assessed through the metacentric height which is given by Equation 5:

$$\overline{GM} = \overline{KB} + \overline{BM} - \overline{KG} - \overline{\Delta GM} \quad [5]$$

with \overline{GM}	metacentric height
\overline{KB}	distance between the gate bottom (K) and the buoyancy center (B)
\overline{KG}	distance between the gate bottom (K) and the gravity center (G)
\overline{BM}	metacentric radius = I_T / ∇ where I_T water plane moment of inertia ∇ under water volume (displacement)
$\overline{\Delta GM}$	“free surface effect” due to water ballast = i / ∇ where i free surface moment of inertia

The role of solid ballast is to lower the gravity center and thus to increase the metacentric height. In case of damage the mass equilibrium is restored by pumping out water ballast but the gravity center goes up so that the metacentric height decreases. The minimum height of solid ballast is thus given by Equation 5 in case of damage and by considering a minimum 40 cm metacentric height as floating stability condition. The considered density of solid ballast is 70 kN/m³ (steel blocks).

SCANTLING OPTIMIZATION

The Van Cauwelaert lock gate is composed by steel stiffened plates. A least weight optimization of the gate scantling (profile sizes, dimensions and spacing) can be performed with the LBR-5 software.

LBR-5 SOFTWARE

Structural design is always defined during the earliest phases of a project. It is thus not difficult to understand why a preliminary design stage optimization tool is attractive. This is precisely the way the LBR-5 optimization software for stiffened structures was conceptualized (Rigo 2001a, Rigo 2001b, Rigo 2003).

LBR-5 is an integrated package to analyze and optimize naval and hydraulic structures at their earliest stages: tendering and preliminary design. Initial scantling is not mandatory. Designers can start directly with an automatic search for optimum sizing (scantling). Design variables (plate thicknesses, stiffener dimensions and spacing) are freely selected by the user. LBR-5 is composed of 3 basic modules (OPTI, CONSTRAINT and COST). The user selects the relevant constraints (geometrical and structural constraints) in external databases. When the optimization deals with least construction costs, unitary material, welding, cutting and labor costs must be specified by the user to define an explicit objective function (not empirical). For least weight, these unitary costs are not used and the objective function depends only on the geometrical parameters. Using all these data (constraints, objective function and sensitivity analysis), the optimum solution is found using an optimization algorithm based on convex linearizations and a dual approach (Fleury 1989, Rigo and Fleury 2001). Independent of the number of design variables and constraints, the number of iterations requiring a complete structural re-analysis is limited to 10 or 15.

MODELLING DESCRIPTION

The LBR-5 mesh model (Figure 3) of the Van Cauwelaert lock gate includes:

- 25 stiffened panels with 9 design variables each, i.e.:
 - Plate thickness
 - For longitudinal stiffeners and transverse frames:
 - Web height and thickness
 - Flange width
 - Spacing
- 155 design variables (some design variables of stiffened panels are not considered)
- 95 equality constraints, e.g. to impose uniform frames spacing and transverse symmetry
- 213 geometrical constraints
- 1400 structural constraints (280 per loading case), such as:
 - Plate yielding (Von Mises)
 - Stiffener yielding (web and flange)
 - Frame yielding (web and flange)
 - Stiffener ultimate strength
- 1 constraint imposing the gravity center cannot go up during the optimization process

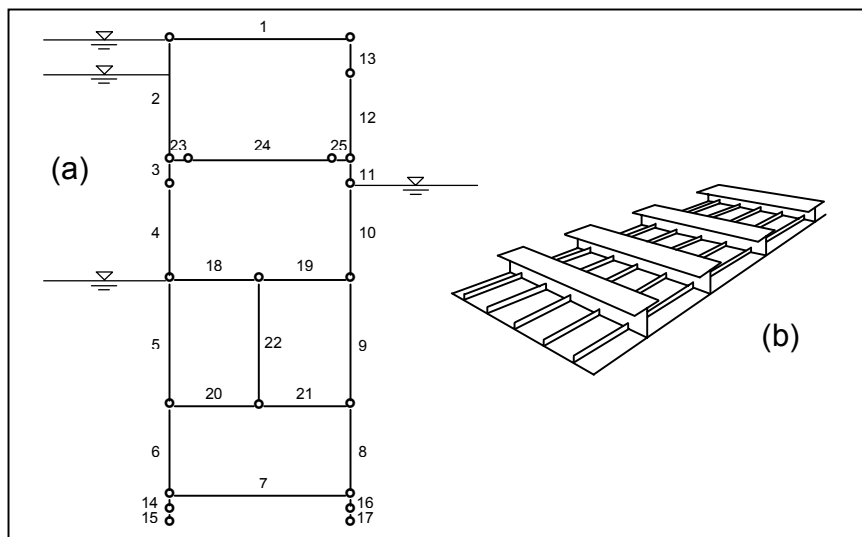

Figure 3: LBR-5 Modelling
(a) Mesh Model of the Van Cauwelaert Lock Gate (b) Stiffened Panel Element

Five loading cases are considered during the optimization process:

- Three different levels of the Scheldt River (Figure 1)
- Emptying of the port when the Scheldt River is at the average level
- 240 kN/m² test pressure in one floating tank when the gate is outside water

At both vertical extremities the gate is considered as simply supported. Moreover a support on the floor (at the foot of the gate) allows reducing the global stress level and general deflection. Nevertheless the horizontal reaction is there limited to 30 % of the horizontal resultant to ensure watertightness.

GLOBAL OPTIMIZATION

The parameters of the global optimization are the following:

- Bottom level of the floating tanks (height of the floating tanks)
- Number of stiffened sections along the gate
- Ratio between the number of stiffened and watertight sections
- Design variables considered in the LBR-5 mesh model

Several geometries are generated by varying the first three parameters. For each geometry, the LBR-5 mesh model (Figure 3) is updated and a LBR-5 least weight optimization is performed. For the optimum gate scantling, minimum volumes of water and solid ballast are then determined through Equations 3 and 5.

The global optimization process is described in Figure 4.

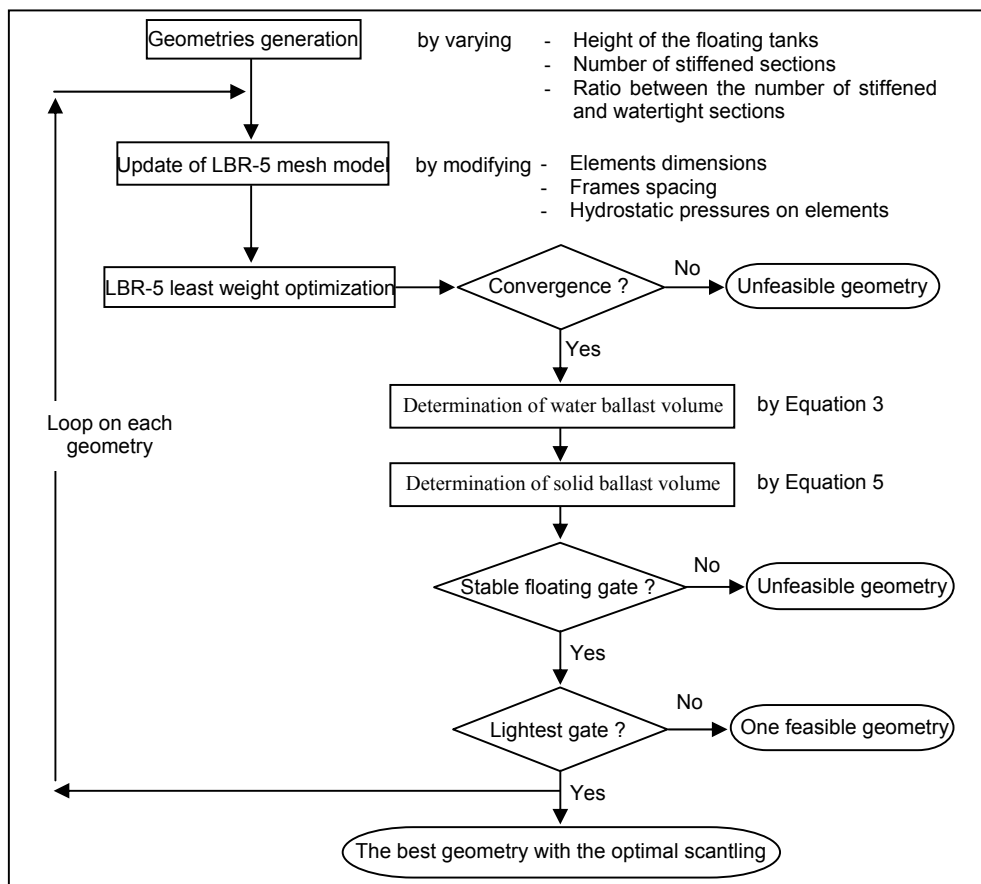

Figure 4: Global Optimization Process

First a coarse optimization was performed with the following values of the optimization parameters:

- Height of the floating tanks (m): 4 / 4.5 / 5 / 5.5 / 6 / 6.5 / 7 / 7.5 / 8 / 8.5 / 9
- Number of stiffened sections: 8 / 9 / 11 / 14 / 17 (spacing between 2.0 and 4.0 m)
- Ratio between the number of stiffened and watertight sections: 1 / 2 / 3 / 4

The analysis of the results shows the floating stability increases with the height of the floating tanks up to a maximum for 7.5 m high tanks. Nevertheless the weights of the gate structure and the solid ballast increase with the same parameter too. The problem is thus to find the minimum height of the floating tanks while ensuring the floating stability. Moreover the number of stiffened sections has to be higher than 14 to satisfy the structural constraints considered in LBR-5. As for the ratio between the number of stiffened and watertight sections, the best compromise value is 2.

A fine optimization was then carried out with the following values of the optimization parameters:

- Height of the floating tanks (m): 4.8 / 4.9 / 5 / 5.1 / 5.2 / 5.3 / 5.4 / 5.5 / 5.6 / 5.7 / 5.8
- Number of stiffened sections: 15, 16, 17 (spacing between 2,0 and 2,5 m)
- Ratio between the number of stiffened and watertight sections: 2

For all geometries (Table 1), the resultant weight is given in Figure 5.

Table 1: Generated Geometries

Geometry	Height of the floating tanks (m)	Number of stiffened sections	Geometry	Height of the floating tanks (m)	Number of stiffened sections	Geometry	Height of the floating tanks (m)	Number of stiffened sections
1	4.8	17	13	5.2	17	25	5.6	17
2		16	14		16	26		16
3		15	15		15	27		15
4	4.9	17	16	5.3	17	28	5.7	17
5		16	17		16	29		16
6		15	18		15	30		15
7	5.0	17	19	5.4	17	31	5.8	17
8		16	20		16	32		16
9		15	21		15	33		15
10	5.1	17	22	5.5	17			
11		16	23		16			
12		15	24		15			

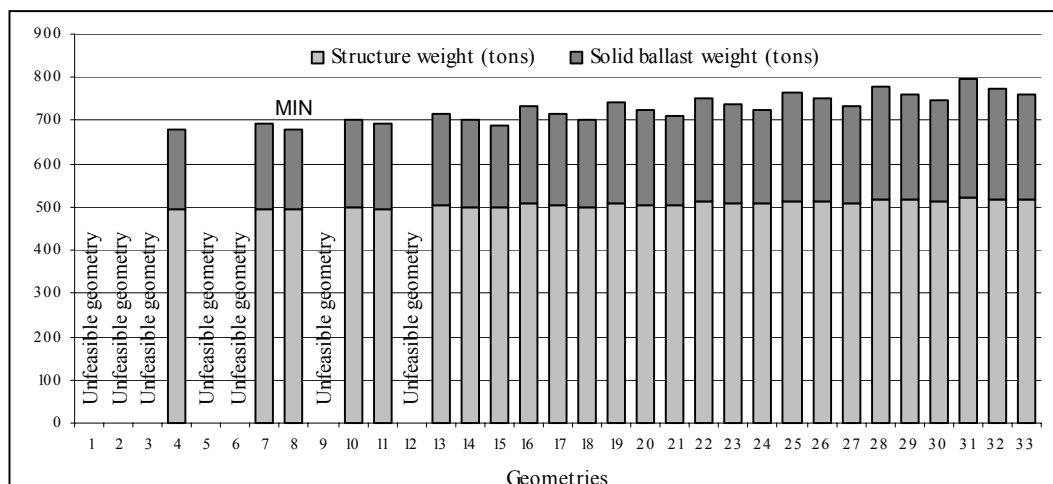

Figure 5: Resultant Weights

The minimum resultant weight corresponds to geometry # 8, for which the weights of the gate structure and the solid ballast are equal to 494 tons and 185 tons respectively. The optimized gate of the Van Cauwelaert lock is shown in Figure 6.

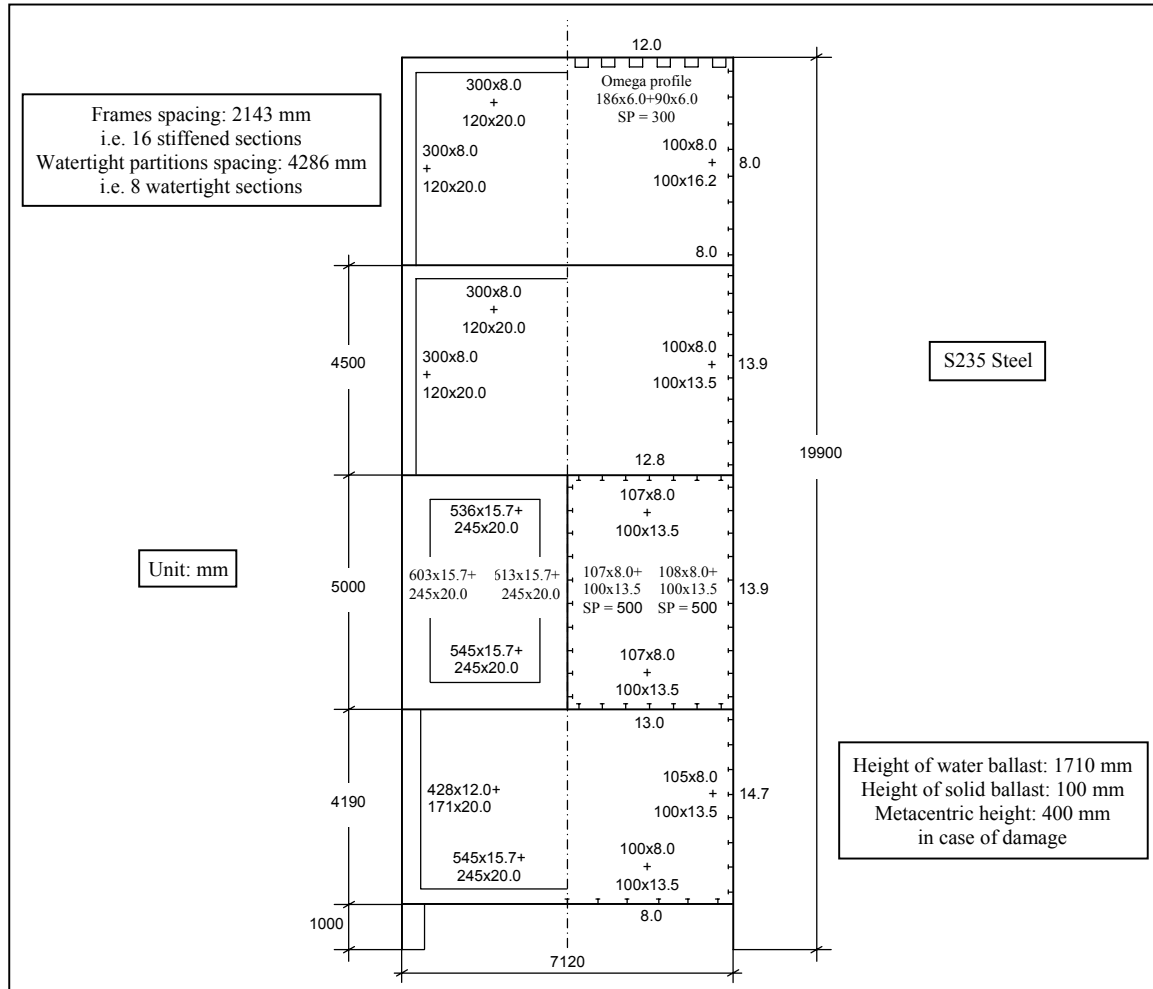

Figure 6: Optimized Van Cauwelaert Lock Gate

The LBR-5 optimized scantling, given in Figure 6, is not “ready to use”. To establish execution plans and for practical and constructive reasons, standardization is required. In addition, at the final design stage, LBR-5 has to be used as a complement to other specific analyses to get, for instance, stress concentration factors, fatigue strength, vibration level, etc.

The computer time required for the fine optimization (33 generated geometries) was 38 minutes with a 1.70 GHz Pentium laptop.

CONCLUSIONS

The LBR-5 software allows minimizing the weight or the cost of stiffened structures by optimizing their scantling. As shown in this paper, LBR-5 can also be integrated in a global process to perform multi-objective optimization and take into account shape design variables. Indeed the structure weight and the metacentric height were the objective functions in this

example while the height of the floating tanks was a shape design variable. LBR-5 is a very low time-consuming software so that the global optimization of the Van Cauwelaert lock gate was carried out in less than 40 minutes.

ACKNOWLEDGMENTS

The present study was realized in collaboration with the LIN department of the Belgian Ministry of the Flemish Community. Thanks to J-P Pecket and T Richir who actively participated at the study.

REFERENCES

- FLEURY, C. (1989). "CONLIN, An Efficient Dual Optimizer Based on Convex Approximation Concepts". *Structural Optimization*, 1: pp. 81-89.
- PECQUET, J.-P. (2005). *Avant-Projet d'une Porte d'Ecluse Flottante pour le Port d'Anvers*. Master Thesis, Department of Civil Engineering., Univ. of Liege, Belgium
- RICHIR T., PECKET J.-P., TODERAN C., RIGO P. (2006): "Optimization of a Rolling and Floating Lock Gate for the Port of Antwerp", ICCO-ASCE: 2006, Int'l Conf. on Computing in Civil Engineering of ASCE, Paper IC-23, Canada, June 2006, pp. 155-163
- RIGO, P. (2001a) "A Module-Oriented Tool for Optimum Design of Stiffened Structures". *Marine Structures*, 14/6: pp. 611-629
- RIGO, P. (2001b) "Least-Cost Structural Optimization Oriented Preliminary Design". *Journal of Ship Production*, 17/4, pp. 202-215
- RIGO, P.; FLEURY, C. (2001) "Scantling Optimization Based on Convex Linearizations and a Dual Approach". *Marine Structures*, 14/6: pp. 631-649
- RIGO, P. (2003) "An Integrated Software for Scantling Optimization and Least Production Cost". *Ship Technology Research*, 50: pp. 126-141