

# Colour and Colorimetry Multidisciplinary Contributions

Vol. XII B

Edited by Davide Gadia



*[www.gruppodelcolore.it](http://www.gruppodelcolore.it)*

*Regular Member*  
*AIC Association Internationale de la Couleur*

Colour and Colorimetry. Multidisciplinary Contributions. Vol. XII B  
Edited by Davide Gadia – Dip. di Informatica – Università degli Studi di Milano

Layout by Davide Gadia

ISBN 978-88-99513-04-7

© Copyright 2016 by Gruppo del Colore – Associazione Italiana Colore  
Piazza C. Caneva, 4  
20154 Milano  
C.F. 97619430156  
P.IVA: 09003610962  
[www.grupodelcolore.it](http://www.grupodelcolore.it)  
e-mail: [redazione@grupodelcolore.it](mailto:redazione@grupodelcolore.it)

Translation rights, electronic storage, reproduction  
and total or partial adaptation with any means reserved for all countries.

Printed in the month of October 2016

# **Colour and Colorimetry. Multidisciplinary Contributions Vol. XII B**

*Proceedings of the 12<sup>th</sup> Conferenza del Colore*

*Joined meeting with:*

*AIDI Associazione Italiana di Illuminazione*

*Colour Group Great Britain (CG-GB)*

*Centre Français de la Couleur (CFC-FR)*

*Colourspot (Swedish Colour Centre Foundation)*

*Comité del color (Sociedad Española de Óptica)*

*Groupe Français de l'Imagerie Numérique Couleur (GFINC)*

*Politecnico di Torino*

*Turin, Italy, September 08-09, 2016*

## **Organizing Committee**

Davide Gadia  
Anna Marotta  
Roberta Spallone

## **Program Committee**

Alessandro Farini  
Massimiliano Lo Turco  
Veronica Marchiafava  
Marco Vitali

## **Organizing Secretariat**

Veronica Marchiafava – GdC-Associazione Italiana Colore  
Marco Vitali – Politecnico di Torino

## Scientific Committee – Peer review

- Chiara Aghemo** | Politecnico di Torino, IT  
**Antonio Almagro** | Escuela de Estudios Árabes, ES  
**Fabrizio Apollonio** | Università di Bologna, IT  
**John Barbur** | City University London, UK  
**Cristiana Bedoni** | Università degli Studi Roma Tre, IT  
**Laura Bellia** | Università degli Studi di Napoli Federico II, IT  
**Giordano Beretta** | HP, USA  
**Berit Bergstrom** | NCS Colour AB, SE  
**Giulio Bertagna** | B&B Colordesign, IT  
**Janet Best** | Colour consultant, UK  
**Marco Bevilacqua** | Università di Pisa, IT  
**Fabio Bisegna** | Sapienza Università di Roma, IT  
**Aldo Bottoli** | B&B Colordesign, IT  
**Patrick Callet** | École Centrale Paris, FR  
**Jean-Luc Capron** | Université Catholique de Louvain, B  
**Antonella Casoli** | Università di Parma, IT  
**Céline Caumon** | Université Toulouse2, FR  
**Vien Cheung** | University of Leeds, UK  
**Michel Cler** | Atelier Cler Études chromatiques, FR  
**Oswaldo Da Pos** | Università degli Studi di Padova, IT  
**Arturo Dell'Acqua Bellavitis** | Politecnico di Milano, IT  
**Hélène De Clermont-Gallerande** | Chanel Parfum beauté, FR  
**Julia De Lancey** | Truman State University, Kirsville-Missouri, USA  
**Reiner Eschbach** | Xerox, USA  
**Maria Linda Falcidieno** | Università degli Studi di Genova, IT  
**Patrizia Falzone** | Università degli Studi di Genova, IT  
**Renato Figini** | Konica-Minolta, IT  
**Agnès Foiret-Collet** | Université Paris1 Panthéon-Sorbonne, FR  
**Marco Frascarolo** | Università La Sapienza Roma, IT  
**Davide Gadia** | Università degli Studi di Milano, IT  
**Marco Gaiani** | Università di Bologna, IT  
**Anna Gueli** | Università di Catania, IT  
**Robert Hirschler** | Serviço Nacional de Aprendizagem Industrial, BR  
**Francisco Imai** | Canon, USA  
**Muriel Jacquot** | ENSAIA Nancy, FR  
**Kay Bea Jones** | Knowlton School of Architecture, Ohio State University, USA  
**Marta Klanjsek Gunde** | National Institute of Chemistry- Ljubljana, SLO  
**Guy Lecerf** | Université Toulouse2, FR  
**Massimiliano Lo Turco** | Politecnico di Torino, IT  
**Maria Dulce Loução** | Universidade Tecnica de Lisboa, P  
**Lia Luzzatto** | Color and colors, IT  
**Veronica Marchiafava** | IFAC-CNR, IT  
**Gabriel Marcu** | Apple, USA  
**Anna Marotta** | Politecnico di Torino IT  
**Berta Martini** | Università di Urbino, IT  
**Stefano Mastandrea** | Università degli Studi Roma Tre, IT  
**Louisa C. Matthew** | Union College, Schenectady-New York, USA  
**John McCann** | McCann Imaging, USA  
**Annie Mollard-Desfour** | CNRS, FR  
**John Mollon** | University of Cambridge, UK  
**Claudio Oleari** | Università degli Studi di Parma, IT  
**Sonia Ovarlez** | FIABILA SA, Maintenon, FR  
**Carinna Parraman** | University of the West of England, UK  
**Laurence Pauliac** | Historienne de l'Art et de l'Architecture, Paris, FR  
**Giulia Pellegrini** | Università degli Studi di Genova, IT  
**Luciano Perondi** | Isia Urbino, IT  
**Silvia Piardi** | Politecnico di Milano, IT  
**Marcello Picollo** | IFAC-CNR, IT  
**Angela Piegari** | ENEA, IT  
**Renata Pompas** | AFOL Milano-Moda, IT  
**Fernanda Prestileo** | ICVBC-CNR, IT  
**Boris Pretzel** | Victoria & Albert Museum, UK  
**Paola Puma** | Università degli Studi di Firenze, IT  
**Noel Richard** | University of Poitiers, FR  
**Katia Ripamonti** | University College London, UK  
**Alessandro Rizzi** | Università degli Studi di Milano, IT  
**Maurizio Rossi** | Politecnico di Milano, IT  
**Michela Rossi** | Politecnico di Milano, IT  
**Elisabetta Ruggiero** | Università degli Studi di Genova, IT  
**Michele Russo** | Politecnico di Milano, IT  
**Paolo Salonia** | ITABC-CNR, IT  
**Raimondo Schettini** | Università degli Studi di Milano Bicocca, IT  
**Verena M. Schindler** | Atelier Cler Études chromatiques, Paris, FR  
**Andrea Siniscalco** | Politecnico di Milano, IT  
**Roberta Spallone** | Politecnico di Torino, IT  
**Christian Stenz** | ENSAD, Paris, FR  
**Andrew Stockman** | University College London, UK  
**Ferenc Szabó** | University of Pannonia, H  
**Delphine Talbot** | University of Toulouse 2, FR  
**Raffaella Trocchianesi** | Politecnico di Milano, IT  
**Stefano Tubaro** | Politecnico di Milano, IT  
**Francesca Valan** | Studio Valan, IT  
**Marco Vitali** | Politecnico di Torino, IT  
**Alexander Wilkie** | Charles university Prague, CZ

## Organizers:



## Patronages:



# Index

## 1. COLOUR AND MEASUREMENT / STRUMENTATION.....9

**The Self-luminous Neutral Scale in the OSA-UCS system and Whittle's Formula 11**

*C. Oleari, M. Melgosa*

**Evolution of colours in football shirts through colorimetric measurements: Fiorentina's case 19**

*A. Farini, E. Baldanzi, M. Raffaelli, F. Russo*

**A natural method to describe colours under different light sources 27**

*O. da Pos, P. Fiorentin*

## 2. COLOUR AND DIGITAL ..... 39

**Random Spray Retinex and its variants STRESS and QBRIX: Comparison and Experiments on Public Color Images 41**

*M. Lecca, A. Rizzi, G. Gianini*

**A technique to ensure color fidelity in automatic photogrammetry 53**

*M. Gaiani, F. I. Apollonio, A. Ballabeni, F. Remondino*

**Photometric and photorealistic representation of luminaires in 3D software 67**

*A. Siniscalco, G. Guarini*

## 3. COLOUR AND LIGHTING .....79

**Warm white, neutral white, cold white: the design of new lighting fixtures for different working scenarios 81**

*D. Casciani, F. Musante, M. Rossi*

**Daylight-simulator evaluation by "Special metamerism index: change in illuminant" (Computer program) 93**

*G. Simone, C. Oleari*

**Unified Profiles of Spectral Data to support Spatial and Dynamic Color Designs 103**

*M. Reisinger*

**The experience of equivalent luminous colors at architectural scale 109**

*U. Besenecker, T. Krueger, J. Bullough, Z. Pearson, R. Gerlach*

**4. COLOUR AND PSYCHOLOGY .....119**

**Variational achromatic induction and beyond 121**

*G. Gronchi, E. Provenzi*

**LED light scenes for artworks colour perception 129**

*L. Bellia, F. Fragliasso, E. Stefanizzi*

**The Impact of Color on Increasing Self-Confidence among People with Multiple Sclerosis Disease 141**

*B. Abdollahi Gohar, M. Khalili*

**From artistic expression to scientific analysis of color texture 151**

*A. Bony, L. Noury, C. Fernandez-Maloigne*

**5. COLOUR AND RESTORATION .....163**

**The color of fluorescence: non-invasive characterization of fluorescent pigments used in contemporary art 165**

*M. Gargano, L. Bonizzoni, L. Cerami, S. Francone, N. Ludwig*

**Innovative methods for a recognizable gold leaf integration 173**

*R. Capezio, T. Cavaleri, G. Piccablotto, M. Pisani, P. Triolo, M. Zucco*

**Diagnostic study on original stamps of the Kingdom of Sardinia 185**

*T. Cavaleri, A. Conte, A. Piccirillo*

**6. COLOUR AND BUILT ENVIRONMENT .....197**

**Colour, Shape and Pattern on New Shading Façades 199**

*A. Premier*

**Questioning Mediterranean white 207**

*M. P. Iarossi, C. Pallini*

**Colour in the urban environment: a tool for the chromatic analysis of spatial coherence 219**

*L. Nguyen, J. Teller*

**Contemporary residential streetscape: how colors and material differ from the traditional streetscape. A case study in Tokyo 231**

*L. Alessio*

**Chromatic experiences: from the territory to the industry 243**

*L. Perdomo*

**7. COLOUR AND DESIGN .....255**

**Repetition of Color in the Nubian painting 257**

*S. Ahmed Ibrahim , H. Ahmed Ragab*

**Impressionist style in the design for printing women clothes fabric 269**

*A. H. F. Sanad*

**Stability disruption of a nail polish shade 281**

*C. Pierron, D. Roger, G. Planeix, N. Baudouin, H. de Clermont-Gallerande*

**Don't Poles like colors? 283**

*B. Groborz*

**8. COLOUR AND CULTURE .....295**

**Colour as a continuous protagonist of the multidimensionality of plastic languages –“Invited Paper” 297**

*Á. García Codoner*

**From Skeuomorphism to Material Design and back. The language of colours in the 2nd generation of mobile interface design 309**

*L. Bollini*

**“Out of the blue Foam”. MVRDV’s Didden Village as a full-scale model 321**

*F. Colonnese*

**Colour emotion of 15th and 16th centuries Ottoman Divan poetry 331**

*B. Ulusoy, M. Kalpaklı*

**Color and history in designing containers inspired by “KolahFarangi” Building of “Mohtasham” Garden in Rasht city 339**

*L. Akbar*

**Colour of residential architecture of classicism and neoclassicism in Russia 347**

*M. Komarova*

**Sitting in a kitchen full of colours with Claude Monet and Carl Larsson 353**

*M. Ahlqvist-Juhlin, M. Moro*

**9. COLOUR AND EDUCATION .....359**

**Using colors to teach children how to raise a plant 361**

*E. Atighi Lorestani, M. Khalili*

**The effect of color perception on individual skills for children with autism 373**

*M. Khalili, T. Khodayarian, R. Fesharakifard*



## **1. COLOUR AND MEASUREMENT / STRUMENTATION.**



# The Self-luminous Neutral Scale in the OSA-UCS system and Whittle's Formula

<sup>1</sup>Claudio Oleari, <sup>2</sup>Manuel Melgosa

<sup>1</sup> Università degli Studi di Parma, Dip. Fisica e Scienze della Terra, 43214 Parma, Italy \_ [claudio.oleari@fis.unipr.it](mailto:claudio.oleari@fis.unipr.it)

<sup>2</sup> Universidad de Granada, Departamento de Óptica, 18071 Granada, Spain \_ [mmelgosa@ugr.es](mailto:mmelgosa@ugr.es)

## 1. Introduction

Every psychometric color space and perceived color system has an achromatic line defining a neutral scale spanned by a lightness coordinate, e.g.,  $L^*$  in CIELAB and CIELUV,  $L_{OSA}$  in the OSA-UCS system, Munsell's value  $V$  in the Munsell system and Dunkelstufe  $D$  in DIN 6264 system. These neutral scales can be used to calculate barely visible threshold changes of lightness, or equal-appearing supra-threshold steps of grey scale, matching grey appearances, etc. Currently, CIE TC 1-93 *Calculation of Self-Luminous Neutral Scale* is investigating to recommend a neutral scale for self-luminous surfaces [1], and hopefully the new recommendation may complement or help to replace the grey scales previously mentioned.

This work considers the lightness scale of the OSA-UCS system [2-7], at the present defined by the complicate Semmelroth formula, with the intent of evaluating the simpler Whittle formula [8-10] for representing the OSA-UCS lightness. The contribution of this work is divided into two parts:

- 1) the fitting of the OSA-UCS achromatic scale by the Whittle formula as function of the percentage luminance factor  $Y_{10}$ ;
- 2) lightness scale in the OSA-UCS system:
  - a) the definition of a *percentage luminous factor*  $W$  obtained by a fitting of the constant OSA-UCS lightness planes in the  $(L_{OSA}, g, j)$  space by a linear mixing of the tristimulus values, as it is for the percentage luminance factor  $Y_{10}$ ;
  - b) the evaluation of a *relative spectral luminous-efficiency-function*  $W(\lambda)$ , in analogy with the relative spectral luminous efficiency function  $V_{10}(\lambda)$ , which takes into account the Helmholtz-Kohlrausch effect;
  - c) the fitting of the neutral scale from Whittle's formula, denoted by  $L_W$ , as function of the *percentage luminous factor*  $W$  (A comparison is made between the  $L_W$ , obtained from Whittle's formula, and the original  $L_{OSA}$ , obtained from Semmelroth's formula);
  - d) the evaluation of the metrics in the space  $(L_W, G_W, J_W)$  by the Euclidean color-difference formula [11-13].

## 2. OSA-UCS' lightness formula

The OSA-UCS system [2-4] is organized in planes with constant lightness and lightness  $L_{OSA}$  is one of the coordinates that spans the OSA-UCS space.

The color samples of the OSA-UCS atlas are observed on a grey background, i.e. a homogeneous area adjoining the target. Therefore it is found that the lightness  $L_{OSA}$

- 1) is positive if the luminance factor of the color sample is greater than the luminance factor of the grey surround, zero if equal and negative if lower;
- 2) the lightness  $L_{OSA}$  takes into account the *Helmholtz-Kohlrausch effect*, according to which, in addition to luminance, chromaticity also contributes to the brightness;
- 3) the lightness  $L_{OSA}$  takes into account the *crispness effect*, according to which the brightness of a sample is affected by the brightness of the grey surround, whose percentage luminance factor is  $Y_{10} = 30$ .

All this is described by a formula given by the OSA-UCS Committee according to a modification of Semmelroth's formula

$$L_{OSA} = \left[ 5.9(Y_0^{1/3} - \frac{2}{3} + C) - 14.4 \right] \frac{1}{\sqrt{2}} \quad (1)$$

where

$$C = \begin{cases} +0.042|Y_0 - 30|^{1/3} & \text{for } (Y_0 - 30) > 0 \\ -0.042|Y_0 - 30|^{1/3} & \text{for } (Y_0 - 30) \leq 0 \end{cases} \quad \text{with } Y_0 = Y_{10}F \quad (2)$$

$$F = 4.4934x_{10}^2 + 4.3034y_{10}^2 - 4.2760x_{10}y_{10} - 1.3744x_{10} - 2.5643y_{10} + 1.8103$$

and  $Y_{10}$  is a percentage luminance factor of the color sample.

The Helmholtz-Kohlrausch effect is described by the factor  $F$ , which modifies the percentage luminance factor  $Y_{10}$ . The factor  $F$  assumes an equal value on ellipses centered at  $(x_{10} = 0.3859, y_{10} = 0.4897)$ , with a ratio between the axis lengths equal to 1.4138 and with the major axis forming with the axis  $x_{10}$  an angle of  $43.73^\circ$ . The value of  $F$  for the D65 chromaticity is 1, i.e. the illuminant D65 is assumed achromatic.

### 3. Whittle's lightness formula

Paul Whittle proposed a lightness formula for a self-luminous grey-scale as "the simplest and most precise" calculation of the change of luminance  $\Delta Y$  (in  $\text{cd}/\text{m}^2$ ) necessary to achieve any number of *just noticeable differences* (JNDs) of achromatic appearance  $\Delta L_w$ . [8-10]

Whittle's JNDs are calculated from the background luminance,  $Y_b$ , of the increment or decrement  $\Delta Y$ . The luminance interval  $\Delta Y$  is defined as the difference between target luminance  $Y$  and  $Y_b$ :

$$\text{JNDs between } [Y, Y_b \leq Y] = a_1 \log_{10} \left( 1 + b(1-k) \frac{Y - Y_b}{Y_d + Y_b} \right) \quad (3)$$

$$\text{JNDs between } [Y, Y_b \geq Y] = a_2 \log_{10} \left( 1 + b(1-k) \frac{Y_b - Y}{k(Y_b - Y) + Y_d + Y} \right)$$

where  $b = 6.58$ ,  $a_1 = 8.22$ ,  $a_2 = -7.07$ ,  $Y_d = 0.39 \text{ cd}/\text{m}^2$  is the *dark light noise* and  $k$  is a constant in the interval  $[0,1]$  to account for the effect of intraocular scattering, which grows as viewing angle subtended by target decreases.

#### 4. Analysis restricted to only color samples of the OSA-UCS atlas considered as significant for an achromatic scale

Since not all the constant lightness planes have an achromatic sample in the OSA-UCS Atlas, the achromatic scale we are going to propose is obtained from the achromatic specimens, where exist, and by the average of the color specimens with  $|g| \leq 1$ ,  $|j| \leq 1$  elsewhere. These samples are considered as representative of an achromatic color scale in the OSA-UCS system. For these achromatic samples the Helmholtz-Kohlrausch effect is considered negligible and consequently the lightness is only function of the luminance factor  $Y_{10}$ . The Whittle lightness formula in Eq. (3) is defined on an absolute scale while the OSA-UCS system is defined on a relative scale (accordingly, in next Equations the luminance will be substituted by the percentage luminance factor and the JNDs by the lightness). Therefore the constants of the Whittle formula have to be redefined for a relative scale

$$\text{for } Y_{10} > Y_{10,b} \quad L_w = a_1 \log_{10} \left[ 1 + b_1 \frac{(Y_{10} - Y_{10,b})}{(Y_{10,d} + Y_{10,b})} \right] \quad (4)$$

$$\text{for } Y_{10} < Y_{10,b} \quad L_w = a_2 \log_{10} \left[ 1 + b_2 \frac{(-Y_{10} + Y_{10,b})}{(Y_{10,d} + Y_{10})} \right] \quad (5)$$

where  $Y_{10,b} = 30$  is the percentage luminance factor of the background and  $Y_{10,d}$  is the *dark light noise* that is seen in the absence of any light. Equations (4) and (5) provide equal value for  $Y_{10} = Y_{10,b}$ , i.e. for  $L_{\text{OSA}} = 0$ . The constant  $k$ , present in Eq. (3), is supposed equal to 0 for the view of the size of the viewing angle of the OSA-UCS samples.

Next Whittle's formula fitted the  $L_{\text{OSA}}$  lightness data of the color specimens with  $|g| \leq 1$ ,  $|j| \leq 1$ , assuming zero dark light noise and zero intraocular scattering,

$$\text{for } L_{\text{OSA}} > 0 \text{ or } Y_{10} > Y_{10,b} = 30 \quad L_w = 12.2359 \log_{10} \left[ 1 + 1.1076 \frac{(Y_{10} - 30)}{30} \right] \quad (6)$$

$$\text{for } L_{\text{OSA}} < 0 \text{ or } Y_{10} < Y_{10,b} = 30 \quad L_w = -5.2406 \log_{10} \left[ 1 + 2.9615 \frac{(-Y_{10} + 30)}{Y_{10}} \right] \quad (7)$$

with fitting  $RMS < 0.10$  computed on the whole set of color specimens with  $|g| \leq 1$  and  $|j| \leq 1$  of the OSA-UCS atlas. Eqs. (6) and (7) regard only the achromatic scale. Figure 1. plots the Whittle function fitted on the OSA-UCS data, together the data given by the OSA-UCS atlas.

#### 5. Analysis extended to the whole OSA-UCS atlas by fitting lightness with Whittle's formula

##### i) *Spectral luminous efficiency function*

In a controlled visual situation adapted to the D65 illuminant with a color sample on a grey background, lightness depends only by the tristimulus values that specify the color sample and background.

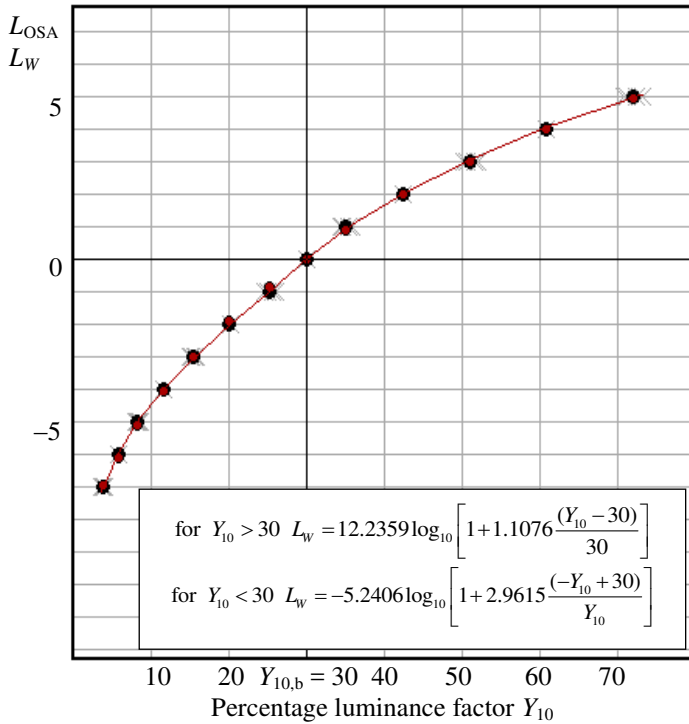

Fig. 1. Plot of the Whittle function (red line) over the data of the OSA-UCS atlas with  $|g| \leq 1$ ,  $|l| \leq 1$  represented by grey crosses ( $\times$ ). The big black dots ( $\bullet$ ) represent the average of the value of the data of the OSA-UCS atlas at equal lightness and the red dots ( $\bullet$ ) represent the value of the Whittle function averaged over the data of the OSA-UCS atlas with  $|g| \leq 1$ ,  $|l| \leq 1$  and equal lightness.

The loci with constant lightness are planes in the OSA-UCS space. The formula of Semmelroth describes the constant lightness loci with surfaces that are no longer planes in tristimulus space. This means that the lightness is a nonlinear function of the tristimulus values. The representation of the lightness by means of a linear function of the tristimulus values of the color sample is here considered as an approximation.

As known the percentage luminance factor  $Y_{10}$  is the tristimulus value that represents the luminous stimulation. First, this analysis searches for fitting the lightness of the OSA-UCS system with a linear function of the tristimulus values of the color samples.

As we will see, the obtained function is almost equal to each value of lightness and this leads us to believe that the linear fit is a good approximation. In analogy to the percentage luminance factor  $Y_{10}$ , that is a coordinate in the tristimulus space, this linear approximation led us to define a *percentage luminous factor*  $W$ , representing a relative luminous stimulation in the OSA-UCS system that takes into account the Helmholtz-Kohlrausch effect in a linear approximation

$$\begin{aligned}
W &= L_X X_{10} + L_Y Y_{10} + L_Z Z_{10} \quad \text{with } L_X = 0.2152, L_Y = 0.7305, L_Z = 0.0761 \\
W &= L_A A + L_B B + L_C C \quad \text{with } L_A = 0.4975, L_B = 0.3487, L_C = 0.1756
\end{aligned} \tag{8}$$

where  $(X_{10}, Y_{10}, Z_{10})$  and  $(A, B, C)$  are the tristimulus values in the  $X_{10}Y_{10}Z_{10}$  reference frame and in the adapted  $ABC$  reference frame [5-7], respectively, which are related by

$$\begin{pmatrix} A \\ B \\ C \end{pmatrix} = \begin{pmatrix} 0.6597 & 0.4492 & -0.1089 \\ -0.3053 & 1.2126 & 0.0927 \\ -0.0374 & 0.4795 & 0.5579 \end{pmatrix} \begin{pmatrix} X_{10} \\ Y_{10} \\ Z_{10} \end{pmatrix} \tag{9}$$

On this basis, it is defined a *relative spectral luminous efficiency function*  $W(\lambda)$ , in analogy with the relative luminous efficiency function  $V_{10}(\lambda)$ , which has a very low variation when lightness changes (Figure 2):

$$\begin{aligned}
W(\lambda) &= L_X \bar{x}_{10}(\lambda) + L_Y \bar{y}_{10}(\lambda) + L_Z \bar{z}_{10}(\lambda) \\
&\quad \text{with } L_X = 0.2152, L_Y = 0.7305, L_Z = 0.0761
\end{aligned} \tag{10}$$

$$\begin{aligned}
W(\lambda) &= L_A \bar{a}(\lambda) + L_B \bar{b}(\lambda) + L_C \bar{c}(\lambda) \\
&\quad \text{with } L_A = 0.4975, L_B = 0.3487, L_C = 0.1756
\end{aligned}$$

where  $(\bar{x}_{10}(\lambda), \bar{y}_{10}(\lambda), \bar{z}_{10}(\lambda))$  and  $(\bar{a}(\lambda), \bar{b}(\lambda), \bar{c}(\lambda))$  are the color-matching functions in the  $X_{10}Y_{10}Z_{10}$  reference frame and in the adapted  $ABC$  reference frame, respectively.

For an analysis of the spectral luminous efficiency function see references [14-18].

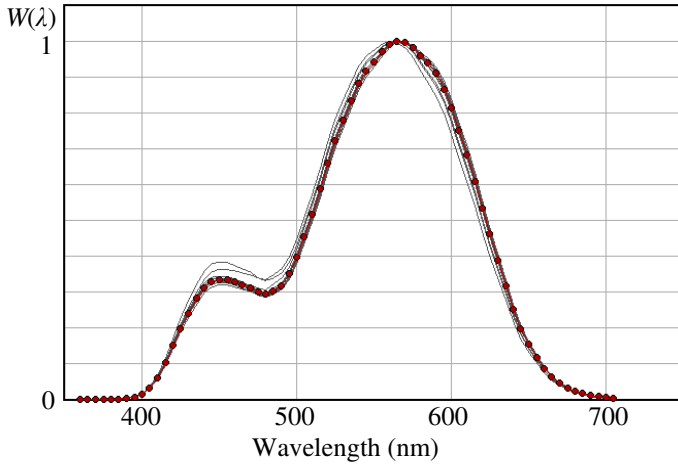
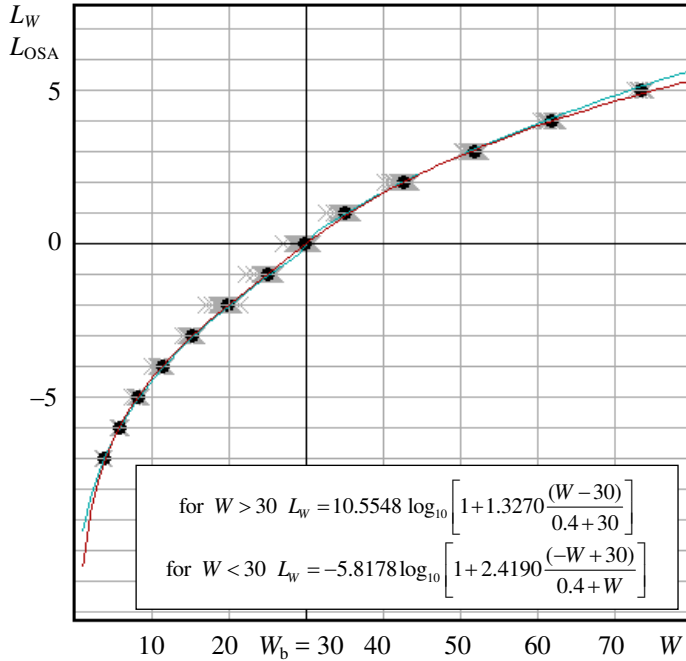

Fig. 2. *Relative spectral luminous efficiency functions* obtained from the different lightness planes of the OSA-UCS system (grey lines) and *relative spectral luminous efficiency function*  $W(\lambda)$  (red dots ● and red line) computed as weighted average, with weights equal to the numbers of color samples belonging to any constant lightness plane .

## ii) Luminous factor and Whittle's formula

The  $L_{OSA}$  lightness has been related to the percentage luminous factor  $W$  for each sample of the OSA-UCS system and the best fit of  $L_W$  by using Whittle's formula is shown in Figure 3.



**Fig. 3.** Whittle's function in Eqs. (11) (12) (red line) over the lightness data of the OSA-UCS atlas represented by grey crosses ( $\times$ ). The big black dots ( $\bullet$ ) represent the average of the value of the  $L_{OSA}$  data at equal lightness and the cyan line represents the results from Semmelroth's formula.

Whittle's formula with best fitting parameters is:

$$\text{for } W > W_b = 30 \quad L_W = 10.5548 \log_{10} \left[ 1 + 1.3270 \frac{(W - 30)}{(0.4 + 30)} \right] \quad \text{with } RMS < 0.12 \quad (11)$$

$$\text{for } W < W_b = 30 \quad L_W = -5.8178 \log_{10} \left[ 1 + 2.4190 \frac{(-W + 30)}{(0.4 + W)} \right] \quad \text{with } RMS < 0.15 \quad (12)$$

where  $W_b = 30$  corresponds to  $L_{OSA} = 0$  and is the percentage luminous factor of the grey background behind the color samples, and the dark light noise is approximated with a 0.4 value. The  $RMS$  value of these fits were computed on the whole OSA-UCS atlas. The two fitted Eqs. (11) and (12) provide equal value for  $W = 30$ , i.e.  $L_{OSA} = 0$ .



iii) *Metrics and Euclidean color-difference formula in the  $(L_W, G_W, J_W)$  space with Whittle's lightness*

The color-difference formulas have been long and deeply studied in recent decades and their study is not yet completed. The OSA-UCS space has been studied with considerable success to represent the color differences [11-13]. Here we consider the Euclidean color-difference formula  $\Delta E_E$  defined in the log-compressed space derived from space  $(L_{OSA}, G, J)$  transferring this formula into the log-compressed space derived from space  $(L_W, G_W, J_W)$  to assess its quality. The Euclidean formula depends on four parameters, which are defined on the experimental color difference data by an optimization process. The *STRESS* quantity [19] statistically quantifies the quality of these formulas. This operation is repeated in the new space  $(L_W, G_W, J_W)$  by using the same experimental data used in the previous work [12] and *STRESS* = 28.42 is improved [*STRESS* = 29.48 in  $(L_{OSA,E}, G_E, J_E)$ ]. The transformations from the tristimulus space to  $(L_W, G_W, J_W)$  space are as follows:

- 1)  $(A, B, C)$ ,  $W$  and  $L_W$  are defined by Eqs. (8), (9), (11) - (12), respectively;
- 2) The coordinates  $(G_W, J_W)$  are defined by

$$\begin{pmatrix} J_W \\ G_W \end{pmatrix} = \begin{bmatrix} 2(0.5735L_W + 7.0892) & 0 \\ 0 & -2(0.7640L_W + 9.2521) \end{bmatrix} \times \begin{bmatrix} 0.1792 & 0.9837 \\ 0.9482 & -0.3175 \end{bmatrix} \begin{pmatrix} \ln\left(\frac{A/B}{0.9366}\right) \\ \ln\left(\frac{B/C}{0.9807}\right) \end{pmatrix} \quad (13)$$

The Euclidean color-difference formula in  $(L_{W,E}, G_{W,E}, J_{W,E})$  is the following

$$\Delta E_{W,E} = \sqrt{(\Delta L_{W,E})^2 + (\Delta G_{W,E})^2 + (\Delta J_{W,E})^2} \quad (14)$$

where

$$L_{W,E} = \left(\frac{1}{b_L}\right) \ln \left[ 1 + \frac{b_L}{a_L} (10L_W) \right] \text{ with } a_L = 2.8628 \text{ and } b_L = 0.0106$$

$$J_{W,E} = C_{W,E} \sin(h_W), \quad G_{W,E} = C_{W,E} \cos(h_W)$$

with

$$h_W = \arctan \left( -\frac{J_W}{G_W} \right)$$

$$C_{W,E} = \left(\frac{1}{b_C}\right) \ln \left[ 1 + \frac{b_C}{a_C} (10C_W) \right] \text{ with } a_C = 1.2204 \text{ and } b_C = 0.0448$$

$$C_W = \sqrt{G_W^2 + J_W^2} .$$

## Bibliografía

- [1] <http://www.cie.co.at/index.php/Technical+Committees>.
- [2] MacAdam, D.L., Uniform color scales, *J. Opt. Soc. Am.* **64**, 1691-1702 (1974).
- [3] MacAdam, D.L., Colorimetric data for samples of OSA uniform color scales, *J. Opt. Soc. Am.* **68**, 121-130 (1978).
- [4] MacAdam, D.L., *Color Measurement*. Springer-Verlag, Berlin (1985), pp. 165-177.
- [5] Oleari, C., Color Opponencies in the system of the uniform color scales of the Optical Society of America. *J. Opt. Soc. Am. A* **21**, 677-682 (2004).
- [6] Oleari, C., Hypotheses for Chromatic Opponency Functions and their Performance on Classical Psychophysical Data, *Color Res. Appl.* **30**, 31-41 (2005).
- [7] Oleari, C., Corresponding color datasets and a chromatic adaptation model based on the OSA-UCS system. *J. Opt. Soc. Am. A* **31**, 1502-1514 (2014).
- [8] Whittle, P., Brightness, discriminability and the 'Crispening Effect', *Vis Res.* **32**, 1493-1507 (1992)
- [9] Whittle, P., The psychophysics of contrast brightness, In A. Gilchrist (Ed.), *Lightness, brightness, and transparency*. Hillsdale: Erlbaum (1994).
- [10] Carter, R.C. & Brill M.H., Calculation of self-luminous neutral scale: How many neutral steps can you see on that display? *J. Soc. For Info. Display* **22**, 177-186 (2014).
- [11] Huertas, R., Melgosa, M. and Oleari, C., Performance of a color-difference formula based on OSA-UCS space using small-medium color differences, *J. Opt. Soc. Am. A* **23**, 2077-2084 (2006).
- [12] Oleari, C., Melgosa, M. and Huertas, R., Euclidean color-difference formula for small-medium color differences in log-compressed OSA-UCS space. *J. Opt. Soc. Am. A* **26**, 121-134 (2009).
- [13] Oleari, C., Melgosa, M. and Huertas, R., Generalization of color-difference formulae for any illuminant and any observer by perfect color-constancy actuation in a color-vision model based on the OSA-UCS system. *J. Opt. Soc. Am. A* **28**, 2226-2234 (2011).
- [14] Wyszecki, G., Correlate for brightness in term of CIE chromaticity coordinates and luminous reflectance, *J. Opt. Soc. Am.*, **57**, 254-257 (1967).
- [15] Kaiser, P.K., and Greenspon, T.S., Brightness Difference and Its Relation to the Distinctness of a Border, *J. Opt. Soc. Am.*, **61**, 962-965 (1971).
- [16] Ware, C., Cowan, W.B., Specification of heterochromatic brightness matches: A conversion factor for calculating luminances of stimuli that are equal in brightness. *National research Council of Canada*. 42 pages, Publication N° 26055 (1983).
- [17] Kaiser, P.K., CIE 1.03. Models of heterochromatic brightness matching. *CIE Journal* **5**, 57-59 (1986).
- [18] Sève, R., *Physique de la couleur*, Masson, Paris (1996)
- [19] García, P. A., Huertas, R., Melgosa, M., and Cui, G., Measurement of the relationship between perceived and computed color differences, *J. Opt. Soc. Am. A* **24**, 1823-1829 (2007).

# Evolution of colours in football shirts through colorimetric measurements: Fiorentina's case

<sup>1</sup>Alessandro Farini, <sup>1</sup>Elisabetta Baldanzi, <sup>1</sup>Marco Raffaelli, <sup>1</sup>Francesco Russo  
<sup>1</sup>CNR-Istituto Nazionale di Ottica alessandro.farini@ino.it, elisabetta.baldanzi@ino.it

## 1. Introduction

Football fans express their identification with their team especially with colours of football shirts. The respect of “tradition” is something so important that very small changes can provoke anger in fans, who express their opposition in news and social media. This could create problems for merchandising[1]. Fiorentina (Florence’s football team) wears purple shirts, very uncommon in football world[2]. Probably for this reason shirt’s colour is a very sensitive topic for Fiorentina’s fans (Fig.1).



Fig. 1 – A graffito “signed” by some Fiorentina’s supporters: the translation is “we say no to the bluish shirt”

In the recent years the introduction of high definition colour television and new strategy of merchandising have assigned an important role to shirt’s colour. Checking and the reproduction of official colours of a football team is nowadays very important.

## 2. Material and Methods

Thank to the help of Museo Fiorentina[3] we have received at our lab 50 original shirts belonging to different sport seasons. Every shirt is called using the year of the second part of the season; as an example, the shirt used during the season 1958-1959 will be called 1959. We have measured every shirt using a Minolta spectrophotometer Cm-2500c with 10 nm of resolution, 45°/0° geometry optics and 360-740 nm wavelength range. We have checked our measurements using, on three samples, a very accurate instrument: a Perkin Elmer spectrophotometer lambda 900 with an integrating sphere. The measurements of the two instruments agree within the experimental error: we decided to use Cm-2500c that permits to see the exact point of measurement. This peculiarity is very useful when we want to check shirts with different hues.

Ageing is a real problem in this kind of measurements. Nowadays every shirt is used only one time but during the the 70's and before every shirt could be used and washed many times during a season, producing a degradation in colours. Furthermore, old shirts could be inhomogeneous in colours: in order to check this hypothesis, we have measured the same shirt in ten different points apparently of the “same purple”. The results expressed in the CIELab system are shown in Tab.1.

L	25.1±0.7
a	27.9±0.7
b	-42.4±0.9

Tab. 1 – Mean and standard deviation obtained by ten measurements on the same shirt changing the measurement point.

### 3. Experimental Results

For every shirt we can examine the reflectance spectrum and the colour coordinates. Here we present only some data in order to present the variability trough years: a complete report will be published in the future together with some psychophysical measurements that want to investigate if every Fiorentina shirt could be called “purple” nowadays. In Fig.2 the reflectance spectra of 1959 (the oldest shirt available at Museo Fiorentina when we made the measurements) 1967, 1968, 1969, 1970 are shown. The first 4 shirts are very dark. This is a typical feature of the shirts in the “golden age” of Fiorentina (Fiorentina won the championship in 1955-1956 and 1968-1969): a radio show devoted to Fiorentina is called “Viola Scuro” (Dark Purple in Italian) in order to create a link with these famous years. The 1970 shirt is redder and less dark.

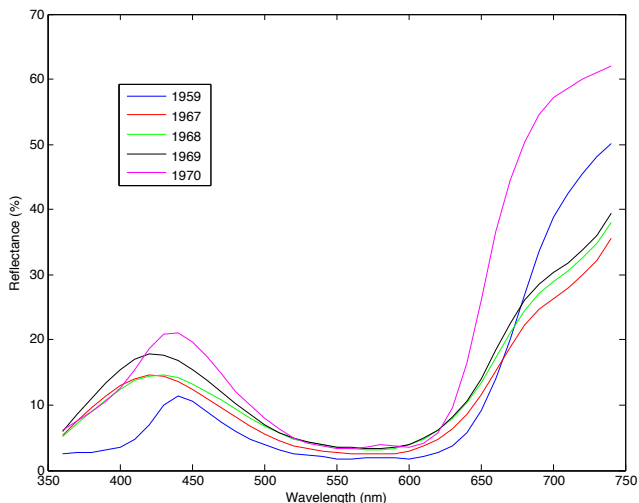

Fig. 2 – Reflectance spectra for 1959-1967-1968-1969-1970.



Fig. 3 – Fiorentina's shirt for season 1958-1959.

1982 (Fig.4) is a very famous shirt for the history of Fiorentina because in that year many football team decided to renovate their shirt and their logo. Probably we can define 1982 as the first year of the “modern football”. The year before Fiorentina’s logo was completely renewed with an overlap between the traditional red fleur-de-lis and a capital "F", for Fiorentina. Supporters disliked it when it was introduced, but the logo remained until 1990. In the same year for the first time in Italy a sponsor name was allowed on the shirt.



Fig. 4 - Fiorentina's shirt for season 1981-1982.

1982 is the brightest shirt in Fiorentina history. Its difference is evident looking at Lightness, but also looking at reflectance spectra (Fig.5).

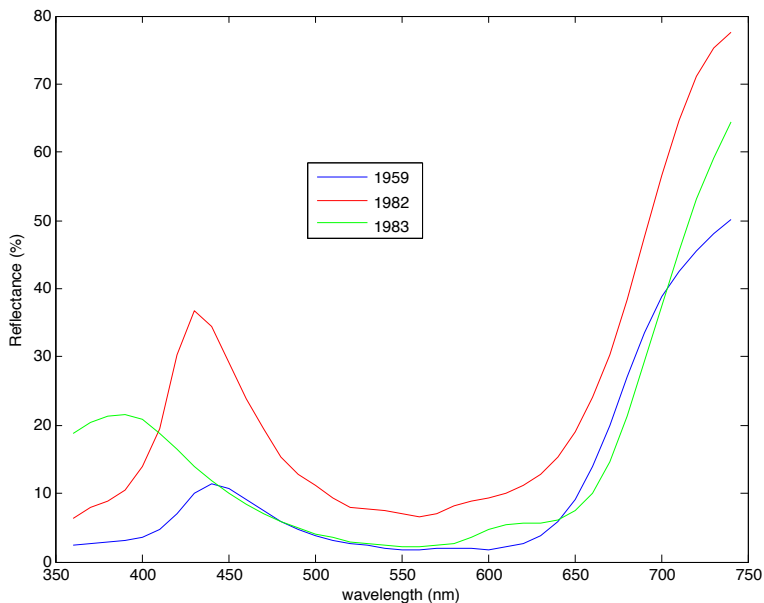

Fig. 5 – Reflectance spectra for 1959-1982-1983. 1982 is brighter compared with 1959 (that we can consider the golden standard) but also with 1983.

Another important year was 1978 because for the first time on Fiorentina’s shirt appeared the logo of the “technical sponsor”: Adidas. The “technical sponsor” is the factory producing shirt, socks, shorts and other part of the kit and should not be confused with the main sponsor previously cited that could be completely unrelated with football’s world. In 1979 Adidas produce the first synthetic shirt (until that year the shirts were made using wool). Despite these great changes reflectance spectra are quite similar (Fig.6) because probably Adidas made a big effort to maintain the same colour.

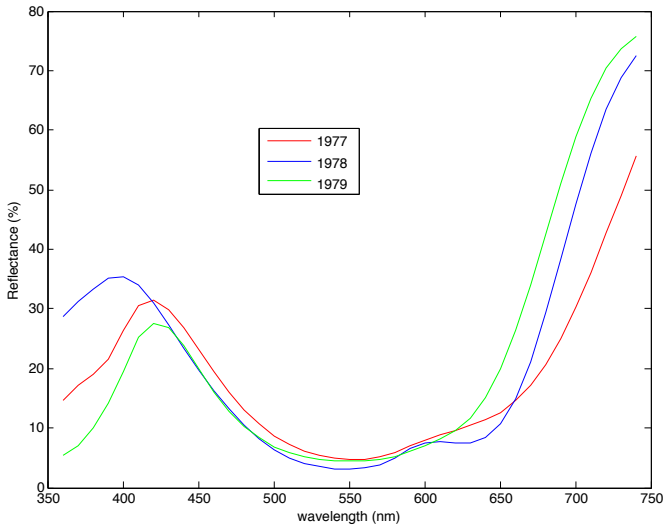

Fig.6– Reflectance spectra for 1977-1978-1979.

Transforming the CIELab coordinates into CIELCh coordinates [4][5] it is possible to study the evolution of the hue. We have calculated  $\Delta H$  (variation in the hue) using as reference point 1959 shirt. Using this approach, it is very evident the change in hue happened in 1970 (Fig.7).

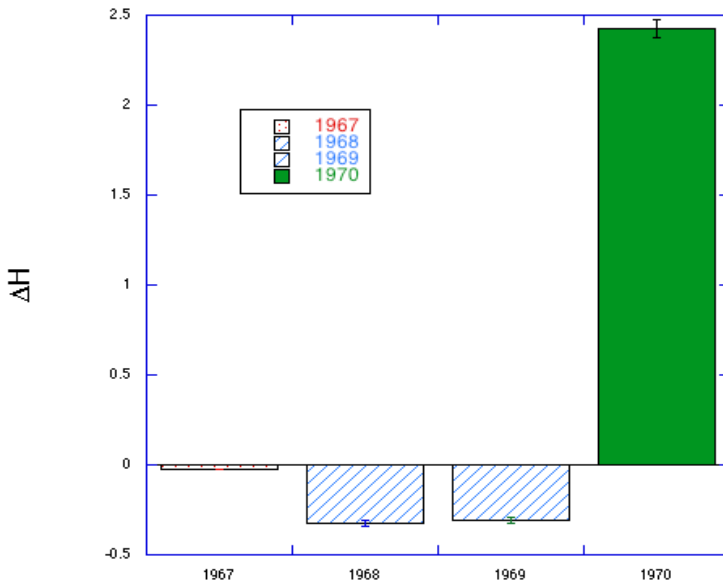

Fig.7–  $\Delta H$  from 1959 evaluated for 1967, 1968, 1969. In 1970 there is a big change in hue.

But particularly interesting is the relationship between technical sponsor and hue. Every technical sponsor tends to use a “proprietary” purple, realising its own colour. Looking at Fig.8 we can note that there is a good correspondence between technical sponsor and hue.

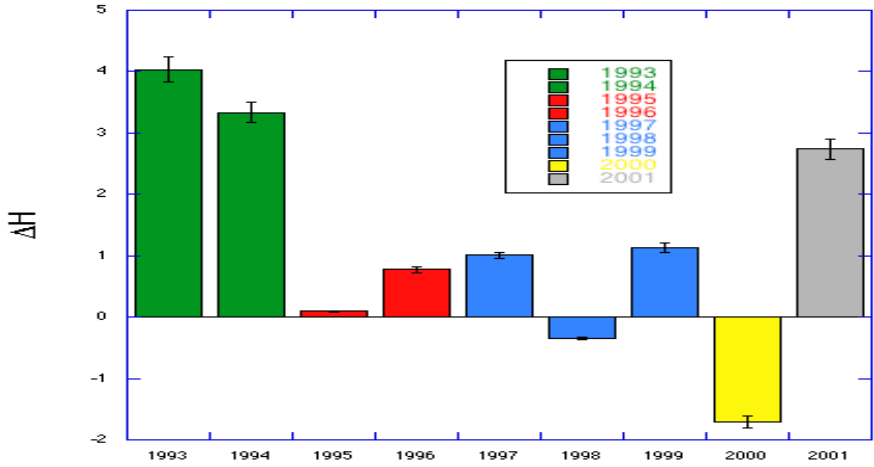

Fig.8-  $\Delta H$  from 1959 evaluated for seasons from 1992-1993 to 2000-2001. At the same colour correspond the same technical sponsor

This behaviour is also evident looking at season from 2002-2003 to 2012-2013 (Fig.9).

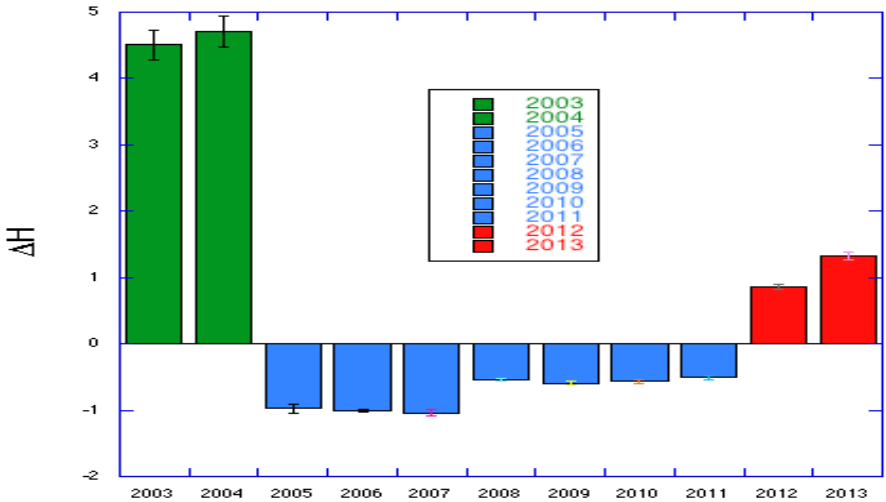

Fig.9-  $\Delta H$  from 1959 evaluated for seasons from 2002-2003 to 2012-2013. At the same colour correspond the same technical sponsor



### 3.1. Comparison between real and fake shirts

Colorimetric analysis could be very useful also to distinguish real historical shirt from fake shirt. A real Fiorentina's shirt for example from 90's can be evaluated 300 €, but a shirt from 60's can be sold at 5000 € and this evaluation provokes a big market for fake reproduction. Recently we have examined a shirt pretending to be an original shirt from season 1969-1970. Comparing this shirt with two original shirts from Museo Fiorentina (Museo Fiorentina receives some shirts directly from players admitted to the Hall of Fame) we have noticed that the red of the fleur-de-lis in the tested shirt is completely different ( $\Delta E=9.3$ ) from the red of the two original shirts. Instead the red of the two original shirts is the same ( $\Delta E=0.7$ ). Obviously this is not a decisive proof, because in those years, before the introduction of official technical sponsor, some differences could be due to different suppliers. But it is a hint that, together with the analysis of textiles and weave, can help an expert in his/her evaluation.

## 4. Conclusions

Through the years purple in Fiorentina's shirts is changed in many different ways. While the first shirts are dark, nowadays we can see very bright shirts that result pleasant on the TV screen. A definitive Fiorentina's purple do not exist: every technical sponsor creates its own purple. A colorimetric analysis could be useful in order to discriminate between real and fake shirts. At the moment we are conducting psychophysical experiments for understanding if every purple in Fiorentina's history could be called purple nowadays.

## 5. Acknowledgments

The authors want to thank Museo Fiorentina and especially its vice-president David Bini for his willingness. He also helped us with many historical data about Fiorentina's shirts.

## Bibliography

- [1] Derbaix, Christian, and Alain Decrop. "Colours and scarves: an ethnographic account of football fans and their paraphernalia." *Leisure Studies* 30.3 (2011): 271-291
- [2] S. Salvi and A. Savorelli, "Tutti I colori del calcio", (Le Lettere, Firenze, 2009).
- [3] [www.museoflorentina.it](http://www.museoflorentina.it).
- [4] Westland S., Ripamonti C. and Cheung V. *Computational Colour Science Using MATLAB*. Wiley, London, 2012
- [5] Wyszecki G. and Stiles W.S. (*Color Science - Concepts and Methods, Quantitative Data and Formulae* (2nd ed.). Wiley-Interscience, London, 2000



# A natural method to describe colours under different light sources

<sup>1</sup>Oswaldo da Pos, <sup>2</sup>Pietro Fiorentin

<sup>1</sup>Dip. Psicologia Generale, Università di Padova, [osvaldo.dapos@unipd.it](mailto:osvaldo.dapos@unipd.it)

<sup>2</sup>Dip. Ingegneria Industriale, [pietro.fiorentin@unipd.it](mailto:pietro.fiorentin@unipd.it)

**Keywords:** elementary colours, colour psychometry, natural colour system

## 1. Introduction

This research belongs to a series of studies on the colour rendering properties of light sources. The peculiarity of the work is the ecological setting according to which observations are made under complete adaptation. For this reason no direct comparison between differently lit colours is made, but observers describe colours once under a light source and in a second time under another source. The rendering capability of the two sources can be derived by computing the differences in the colour descriptions performed in the two conditions. If descriptions are the same, the two sources show the same colour rendering capability, otherwise the larger the differences, the worse the colour rendering of one lamp compared to the other.

## 2. Method.

A good colour description is crucial for this purpose, and we used the method suggested by Hering for developing a natural colour system [1] to evaluate how much a given colour resembles the six elementary colours (W S Y R B G, respectively: white black yellow red blue green). In a viewing box (Figure 1) a single colour patch bent to appear cylindrical and lit by one light source was observed and evaluated according to how much it looked similar to an elementary colour (green for instance).

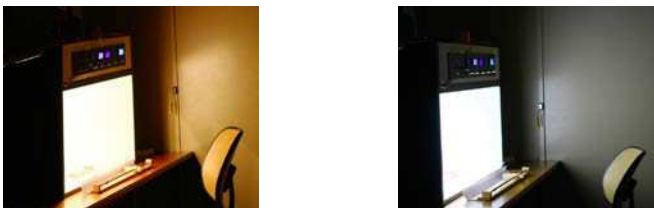

Figure 1. The viewing box used for the experiment. At left lit by an incandescent source; at right it is lit by a LED 6500K source.



C	W	I	S
3055 R50B	2030 R50B	4030 R40B	5040 R50B
1050 B50G	1020 B70G	2040 B50G	4030 B50G
0560 G50Y	0530 G50Y	2060 G50Y	5030 G50Y
1070 Y60R	2020 Y50R	3030 Y30R	5030 Y60R

Figure 2. The 16 samples used in the experiment. C: chromatic, W: whitish, I: intermediate, S: blackish

In different runs all the 16 colours used in the experiment (Figure 2): 4 nuances (a chromatic, a whitish, an intermediate, and a blackish colour) taken out of 4 mixed hues (orange, purple, turquoise, lime) were evaluated for their similarity to all the elementary colours (W S Y R B G, respectively white, black, yellow, red, blue, green); and in different sessions the whole procedure was repeated under the different light source, with complete adaptation to each of them.

A mechanical ruler (Figure 3), over which an arrow could be moved from a 'minimum' position at left (no resemblance) to a 'maximum' position at right (complete similarity), was used to accomplish the subjective evaluations, without any external reference except the two extreme points of the interval.



Figure 3. The mechanical ruler used as a visual scale to evaluate the colour appearance of the experimental samples. The arrow can be moved from left (no similarity) to right (complete similarity), and back. A numerical scale to register the answer is visible only after the arrow has been positioned in the wanted place.

The position chosen by the observer was then quantified by a number, hidden during the evaluation operation, describing the distance of the arrow from the origin, and these measures were later normalized to a 0-100 scale.

Four psychology students with normal colour vision volunteered in the experiment, and performed more than 12000 evaluations in the whole set of different conditions.

## 2. Results

The main results are presented in Figure 4, where all the subjective evaluations of the chromatic components of the observed colours are plotted as a function of each sample, grouped according to their hue. The NCS measures of the same samples, performed by the NCS Colour Scan, are inserted in the same diagram.

Our results are in relatively good agreement with the NCS values, although they are not highly correlated. Experimental mean evaluations are higher and more expanded than the NCS measured notations. The Pearson correlations between raw evaluations of Yellowness, Redness, Blueness and Greenness and the corresponding NCS values are shown in table 1.

sets	Under source A			under source LED			under A+LED		
	Pearson correlation	t	p	Pearson correlation	t	p	Pearson correlation	t	p
$Y_e / Y_{NCS}$	0,83	3,63	0,008	0,86	4,16	0,004	0,84	5,87	0,000
$R_e / R_{NCS}$	0,81	3,44	0,011	0,83	3,69	0,008	0,81	5,16	0,000
$B_e / B_{NCS}$	<b>0,58</b>	<b>1,76</b>	<b>0,121</b>	<b>0,62</b>	<b>1,94</b>	<b>0,094</b>	0,60	2,82	0,000
$G_e / G_{NCS}$	0,94	6,83	0,000	0,88	4,51	0,003	0,91	8,15	0,000

Table 1. Pearson correlations, Student t, and p, between mean evaluations of Yellowness, Redness, Blueness and Greenness and the corresponding NCS values under the source A, LED, and both.  $Y_e$ ,  $R_e$ ,  $B_e$ ,  $G_e$ : evaluated Y R B G;  $Y_{NCS}$ ,  $R_{NCS}$ ,  $B_{NCS}$ ,  $G_{NCS}$ : Y R B G notations according to the NCS (measured by NCS Colour Scan).

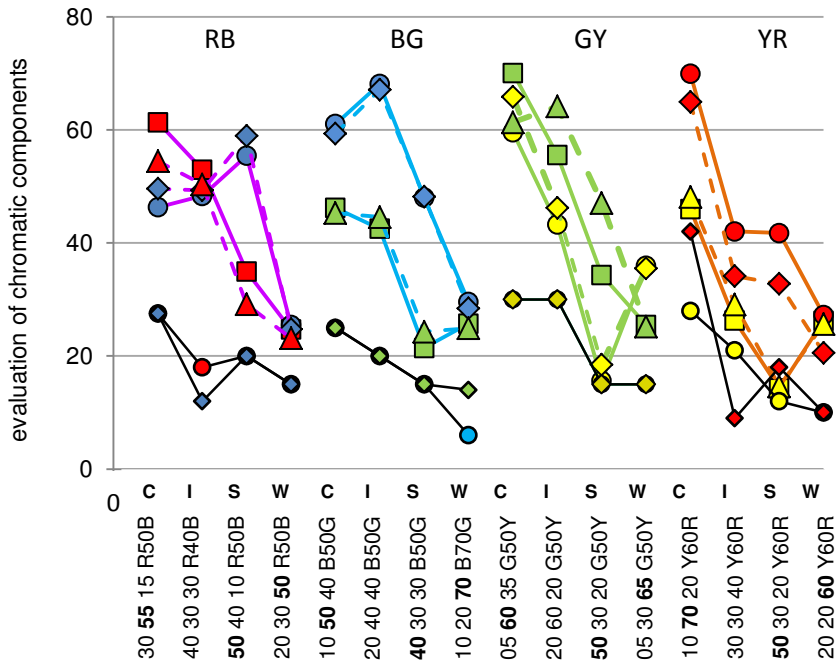

Figure 4. Mean evaluations of the chromatic components, and the NCS notations derived from measurement with NCS Colour Scan for all the studied colours. **Top**: experimental data, coloured lines. *Circle* (one of the two chromatic components, for instance blueness in the first 4 colours) and *square* (the other chromatic component, for instance redness in the same colours) under light source A. *Diamonds* and *triangles*: the same components under light source LED. *Solid line*: light source A; *broken lines*: light source LED. **Bottom**: NCS measured notations, black lines. *Circle* (one of the two chromatic components, for instance redness), and *diamonds* (the other chromatic component, for instance blueness). **Abscissa**: NCS full notations of the studied colours (blackness, chromaticness, whiteness, hue); In bold the most relevant NCS attribute of the samples. C: chromatic samples; I: intermediate sample; S: blackish samples; W: whitish samples.

The evaluations of Greenness are the most correlated to the NCS values, while those of Blueness are the least; moreover correlations of Blueness are not significant if considered separately under the two sources (in bold).

In Figure 4 at the first sight one realises that the distribution of the experimental data is quite different from the distribution of the NCS measured notations, which occupy the lower part of the diagram. While NCS values are relatively small, the experimental mean evaluations are quite higher and dilated; and moreover one can see some peculiarity of the distribution which differentiate the hues being evaluated: when blue appearance is rated in blackish samples, it receives high marks, and lower marks in whitish samples. The contrary happens with yellow samples, which receive higher yellow evaluations in whitish samples, and lower in blackish samples. Something similar, but quite reduced, happens also when redness and greenness are evaluated. This means that there is some interaction between achromatic and chromatic evaluations, which on the contrary should be independent as it happens in the NCS. Therefore we decided to transform the raw data by taking into account these interferences to get subjective values closer to the NCS data.

The transformed evaluation ( $t.ev$ ) is then computed according to the following non-linear equation, in which three components, whiteness ( $W$ ), blackness ( $S$ ), and the specific colour ( $C$ ), contribute to the result:

$$t.ev = m_w * W^{e_w} + m_s * S^{e_s} + m_c * C^{e_c} + \text{offset} \quad (1)$$

where  $m_n$  is a scale factor and  $e_n$  is an exponent, found to minimize the square differences between the transformed results and the NCS values. Results are presented in Figure 5.

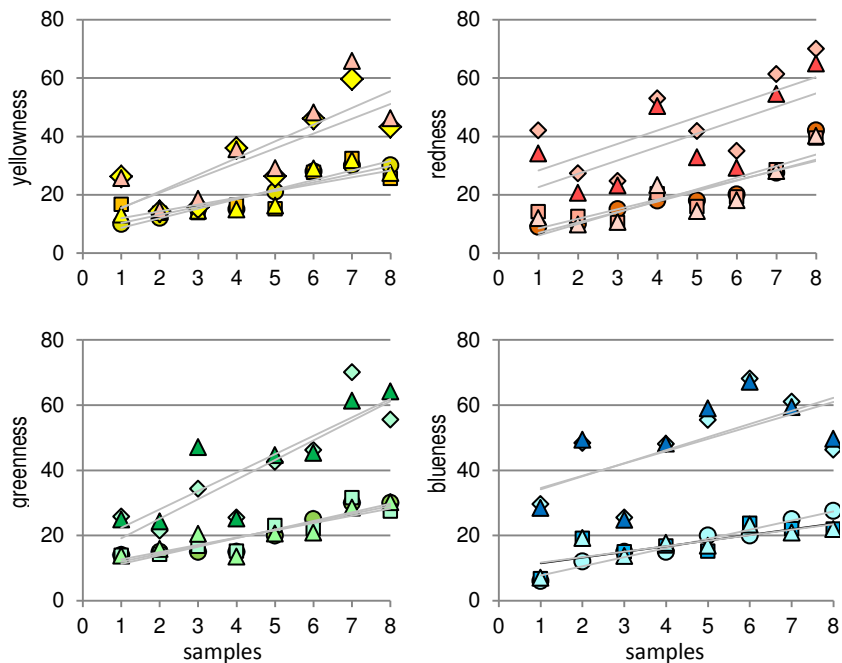

Fig. 5 - Representation of the raw and transformed evaluations of the chromatic components. Circles: NCS notation, diamonds and dark triangles: raw evaluations; squares and light triangles: transformed evaluations. Top left: evaluations of Yellow; top right: evaluations of Red; bottom left: evaluations of Green; bottom right: evaluations of Blue. In abscissa the eight samples which appear of the evaluated colour (for instance the eight yellowish colours).

In figure 5 we see that the non-linearly transformed evaluations are almost superimposed to the NCS corresponding values for each colour, which was the aim of the transformation. Although our method searched for *absolute* evaluations, i.e. independent from other constraints like the evaluations of other colour components, we expected that our results would be correlated with the NCS notations, which on the contrary are interdependent. The transformation seems to have been particularly successful as regard to the increase in correlation of our results with NCS values.

The left column of Figure 6 shows how the chromatic evaluations of the samples change under the two light sources. Points aligned along the diagonal mean there is no change, while deviations from the diagonal means that in one case the specific appearance is more pronounced under a source than under the other.

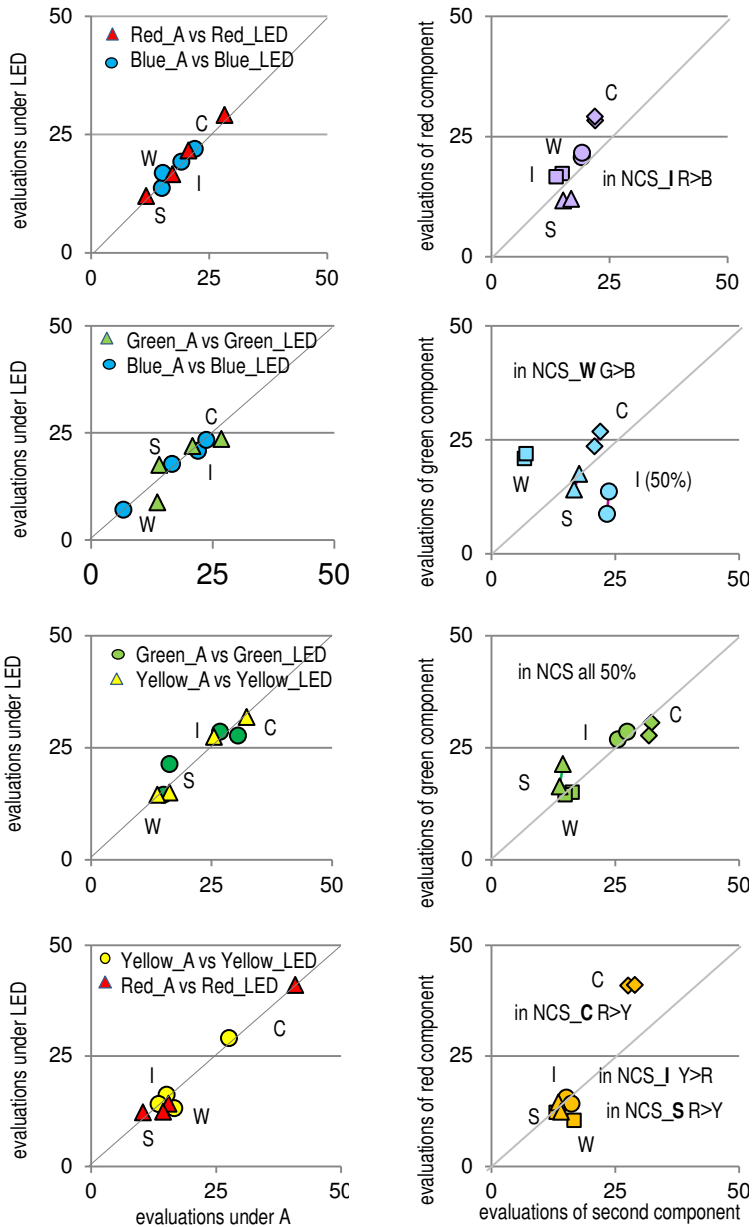

Figure 6. Left column: transformed evaluations of the chromatic components Y R B G under the light source LED as a function of the transformed evaluations under the light source A. Right column: transformed evaluations of the first chromatic component of a sample as a function of the transformed evaluations of the second chromatic component. The label (c, i, w, s) in the pair of symbols is close to the colour observed under A source. Points along the diagonal mean equal evaluations of the two components.

If the evaluations do not differ from one source to the other, the points are lying in the diagonal, otherwise there is a difference in the evaluations, and this means that the source show different colours. Under the LED source greenness is lower in the chromatic (c) turquoise colour (BG) and higher in the blackish (s) turquoise colour; and it is still higher under LED in the lime blackish (s) colours (arrows). Other deviations are circled.

The right column of figure 6 shows how the evaluations of the two chromatic components of each sample appear balanced under the two light sources: points aligned along the diagonal mean equal evaluations of the two colours appearance. The points representing the evaluations of the samples are labelled by C (chromatic sample), W (whitish sample), I (intermediate sample), S (blackish sample), and the label is close to the point corresponding to the evaluation under source A. As most colours in our experiment, considered from the NCS system, are balanced (50% of one colour and 50% of the other colour) the points in the diagram should lie along the diagonal. Deviations from the diagonal mean that one colour is more visible at the cost of the other, and deviations due to the ‘objective’ (according to NCS measures) presence of the two colour appearances is documented inside the diagram; moreover the ratio between the two colour evaluations can be a function of the source under which it is perceived. For instance in chromatic purple samples (C) red evaluation is higher than blue evaluation because their ratio measured in NCS is 60% vs 40% (R40B). On the contrary in the case of the whitish orange sample (W) the yellow component is more evaluated under the source A than under source LED (mean evaluation 16.7 vs 13.1). Probably these deviations are due to the spectral power distributions of the two sources (Figure 7)

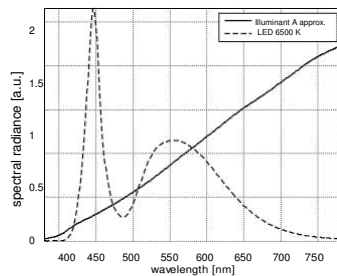

Figure 7. Spectral power distribution of the two light sources used in the experiment.

The following Figure 8 shows the raw evaluations in the left column and the transformed evaluations in the right column, separately for the different hues of the studied samples (orange, purple, turquoise, and lime) as a function of the corresponding measured NCS values.

An interesting results derived from transforming non-linearly the raw evaluations is that on the one side the correlations between data and NCS values notably increase (compare data from table 1 and 2), and on the other side correlations of the colour evaluations with evaluations of White and Black decrease, as it appears in Table 3. This means that the transformed data are essentially related to the chromatic aspect



In figure 6 left side, evaluations of elementary colours observed under source LED (triangles) are plotted as a function of the evaluations observed under the source A of the samples and independent from the achromatic one.

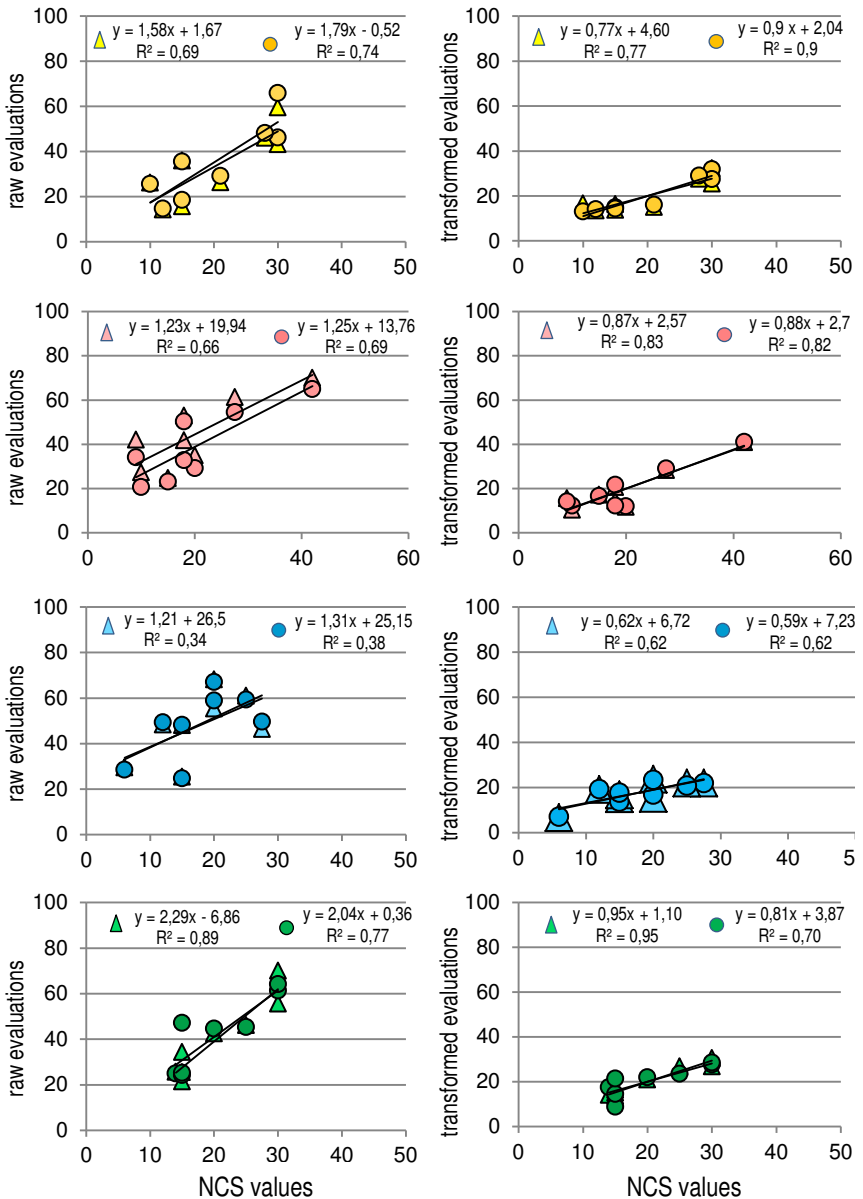

Figure 8. Mean evaluations of the chromatic components as a function of the NCS values. *Left*: raw data; *right*: after non-linear transformation. From the top to the bottom the evaluated component is Yellow, Red, Blue, and Green.

sets	Pearson correlation	t	p	kind	stat.
NCS & A	<b>0,02</b>	0,07	0,94	very low	ns
NCS & LED	<b>0,11</b>	0,40	0,69	very low	ns
A & LED	0,95	11,89	0,0000	very high	significant

Table 1 – Correlation between sets of data **before** non-linear transformation. NCS: values given by NCS Colour Scan; A: evaluations given under source A; LED evaluations given under the source LED.

sets	Pearson correlation	t	p	kind	stat
NCS & A	<b>0,73</b>	4,007	0,001	high	significant
NCS & LED	<b>0,84</b>	5,870	0,000	high	significant
A & LED	0,90	7,534	0,0000	high	significant

Table 2 – Correlation between sets of data **after** non-linear transformation. NCS: values given by NCS Colour Scan; A: evaluations given under source A; LED evaluations given under the source LED.

Light source	B   W	B   S	Y   W	Y   S	G   W	G   S	R   W	R   S
A before_t	0,56	0,52	0,44	0,49	0,02	0,04	0,36	0,26
A after_t	0,38	0,33	0,01	0,07	0,08	0,12	0,24	0,14
LED before_t	0,49	0,49	0,42	0,53	0,23	0,15	0,39	0,29
LED after_t	0,44	0,41	0,05	0,04	0,15	0,13	0,31	0,22

Table 3 – Correlations between the mean evaluations of the chromatic components B Y G R and Whiteness and blackness S, under the two sources A and LED, before and after the non-linear transformation.

In the following Figure 9, the changes in correlations are relevant under both light sources for evaluations of Yellow and Red, while correlations of Blue evaluations changes under the source A, but not under source LED, and in any case changes are low, although in the expected direction.

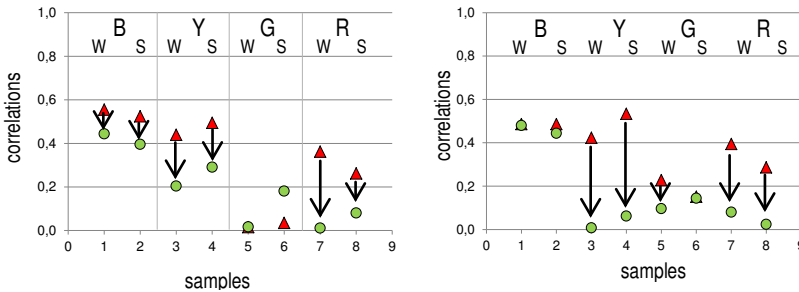

Fig. 9 – Correlations between the mean evaluations of the chromatic components **B Y G R** and Whiteness and blackness **S**, under the two sources A (right) and LED (left); *triangles*: before; *circles*: after the non-linear transformation. Arrows show the decreased correlations.

Correlations of green evaluations changes under source LED for the whitish samples and under source A for the blackish samples, although here in the wrong direction

(this is the only case out of sixteen); the likely reason might be that correlations were extremely low already before the transformation, and therefore could not further decrease: the final correlation with black is still very low, and we can consider irrelevant the change. Although both correlations of B and W, and of B and S decrease, the final values are still relatively high (around 0.44). It seems that it is not possible to free the evaluations of blue from those of black and white.

The following Table 4 shows the changes in correlations between subjective raw evaluations of Yellowness, Redness, Blueness, and Greenness and the corresponding NCS measured values; Table 5 shows the changes in correlations between the raw and transformed evaluations under the sources A and LED.

Y <sub>e</sub>   Y <sub>NCS</sub>	R <sub>e</sub>   R <sub>NCS</sub>	B <sub>e</sub>   B <sub>NCS</sub>	G <sub>e</sub>   G <sub>NCS</sub>		Y <sub>A</sub>   Y <sub>LED</sub>	R <sub>A</sub>   R <sub>LED</sub>	B <sub>A</sub>   B <sub>LED</sub>	G <sub>A</sub>   G <sub>LED</sub>
0,84	0,81	0,60	0,91	raw	0,994	0,987	0,991	0,843
0,99	0,95	0,79	0,94	transformed	0,995	0,987	0,984	0,992

Table 4. Left. Correlations between subjective evaluations of the chromatic components of the sample colours and the corresponding NCS measured notations, computed with raw and transformed data.

Right. Correlations between subjective evaluations *under sources A and LED* for raw and transformed data. Y: Yellowness, R: Redness, B: Blueness, and G: Greenness. e: evaluated colour.

One can see there is a relevant increase in the correlations between subjective and NCS values after the non-linear transformation (Table 4 left). Moreover the correlations between the subjective evaluations under the source A and those under the source LED are very high already with raw evaluations and therefore the increase after transformation is limited (Table 4 right).

Our aim was to find whether and how much colours appear different when viewed under different light sources, A and LED6500K in our case. From the descriptions given by the observers most colours actually appear different in the two conditions. To measure this difference we used the Mahalanobis distance ( $D_M$ ), particularly convenient when the difference has to be computed from multidimensional distributions, as it is the case of colours evaluated by a number of observers.

$$D_M = M(\text{covar}) * [M^T(\text{differences of the means}) * M(\text{covar})] * M(\text{differences of the means}) \quad (2)$$

The calculation is based on the covariance matrix and the differences of the means, and provides also a significance level of the difference. It is also possible to derive a measure of similarity (S) between two distributions from the Mahalanobis distance ( $D_M$ ):

$$S = 100 * \text{EXP}(-0,5 * D_M^2) \quad (3)$$

The assumption is that maximum similarity between colours viewed under two different lights means that colours appear identical and therefore the lamps have the same colour rendering capabilities. If on the contrary similarity is limited, i.e. the same objects appear of different colours under the two sources, a colour rendering index can be calculated as a geometrical average of the degree of similarity of each colour pair (the same object under the two lights) [2].

NCS code	kind	$D_M$	$D_E$	S	p
3055 R50B	P C	2,68	3,1	2,8	0,000
2030 R50B	P I	1,60	1,4	27,9	0,000
4030 R40B	P S	2,04	2,4	12,4	0,000
5040 R50B	P W	7,45	6,0	0,0	0,000
1050 B50G	T C	0,59	0,6	84,2	<b>0,099</b>
1020 B70G	T I	0,64	0,6	81,7	<b>0,067</b>
2040 B50G	T S	0,46	0,4	89,8	<b>0,231</b>
4030 B50G	T W	5,71	5,3	0,0	0,000
0560 G50Y	L C	13,81	8,9	0,0	0,000
0530 G50Y	L I	3,74	3,7	0,1	0,000
2060 G50Y	L S	4,06	4,7	0,0	0,000
5030 G50Y	L W	4,80	4,1	0,0	0,000
1070 Y60R	A C	3,19	3,2	0,6	0,000
2020 Y50R	A I	2,81	3,5	1,9	0,000
3030 Y30R	A S	3,61	3,9	0,1	0,000
5030 Y60R	A W	3,12	3,1	0,8	0,000

Table 5. The table shows the bidimensional Mahalanobis distance ( $D_M$ ) derived from transformed evaluations (the pair of elementary colours evaluated for each sample) under the two light sources. The Euclidean distance ( $D_E$ ) derived from subjective evaluations, the colour similarity (S) from Mahalanobis distance, and the statistical significance (p, assuming critical  $\alpha = 0.05$ ) are also included. *Kind*: characteristics of the colours (P, T, L, A: Purple, Turquoise, Lime, Orange respectively); C: chromatic samples; I: intermediate sample; S: blackish samples; W: whitish samples. Non statistically different distances are in bold.

Worth noting that Purples show strong constancy under the two light sources, as the differences between the colours under the two lights are very small and not significant, while correspondingly their similarity is very high.

We performed the calculations of the colour similarity with the transformed evaluation data, considering the two dimensional distributions (only evaluations of chromatic components, which can be at most two, because of colour opponency).

Usually lightness does not enter in the calculation of a colour rendering index as it depends on the illumination level and not on its spectral power distribution. Then we calculated the *colour similarity* under the two lights still using the transformed evaluations, and in this case we assumed the two chromatic components were a sufficient basis for deriving the colour similarity for the scope of the experiment. Therefore similarity is computed only for the chromatic aspects of colours, not their luminance, which might be increased or decreased according to the power of the sources.

## 5. Conclusions

The experimental method we used here seems particularly useful to accurately describe colours perceived under a specific light source to which the observer can be fully adapted. From different descriptions of the same colours under different light sources we can derive the similarity of the colours under the different lights and then compute a rendering index (by fixing one source as the reference). The method has revealed good capability in detecting similarity and differences between colour observed in different times and in different light to be use both for practical purposes and for theoretical ones, as the study of a phenomenal colour system. Further research is needed to improve the details of the calculation of the rendering

index, after the suggestions by Smet et. al [2].

## **6. References**

[1] The NCS colour system: <http://www.ncscolour.it/about/il-sistema-ncs/>

[2] Smet, K.A.G., Ryckaert W.R., Pointer M.R., Deconinck G., Hanselaer P. A memory colour quality metric for white light sources. *Energy and Buildings* 49 (2012) 216–225



## **2. COLOUR AND DIGITAL**





# Random Spray Retinex and its variants STRESS and QBRIX: Comparison and Experiments on Public Color Images

<sup>1</sup>Michela Lecca, <sup>2</sup>Alessandro Rizzi, <sup>3</sup>Gabriele Gianini

<sup>1</sup>Fondazione Bruno Kessler, ICT – Technologies of Vision, Trento, Italy, lecca@fbk.eu

<sup>2</sup>Università degli Studi di Milano, Dipartimento di Informatica, Milano, Italy, alessandro.rizzi@unimi.it

<sup>3</sup>Università degli Studi di Milano, Dipartimento di Informatica, Crema Campus, Italy, gabriele.gianini@unimi.it

## 1. Introduction

The human color sensation deriving from the observation of a certain point of a scene may differ from the physical luminance of that point. In fact, several experiments revealed that the color sensation at a point depends not only on the photometric properties of that point but also on the physical luminance of the colors surrounding that point and on their spatial arrangement [1] [2] [3].

Retinex [4] is the earliest computational model that attempts to estimate the color sensation by taking into account this empirical evidence. Retinex assumes that the color signal is processed separately by the retina photoreceptors and that there exists a spatial interaction among the colors of the viewed scene. In agreement with these hypotheses, when applied to a digital color picture, Retinex works separately on the three image chromatic channels and processes the color of each image pixel based on the surrounding colors. The result is an enhanced color image, where the chromatic dominant of the light and possible smooth shadows are lowered, while scene details and edges are enhanced.

Many implementations of Retinex are available in the literature [2]. They differ from each other in the way they spatially explore the neighborhood of each pixel and in the way the colors adjacent to that pixel are processed. The original Retinex implementation, analyzed in details in [5], scans the neighborhood of each image pixel  $x$  by a set of random paths ending in  $x$ . The chromatic intensities of the color sensation at  $x$  are obtained as the average, among the random paths, of the relative ratios of the pixel's chromatic intensities along each path, where division by zero is of course prevented. The one-dimensional, path-based scanning approach of the original Retinex has been adopted by many other subsequent Retinex implementations, e.g. [6] [7] [8] [9].

Among the many variants of Retinex, we here describe and compare the Random Spray Retinex (RSR) algorithm presented in [10], and its two subsequent variants STRESS [11] and QBRIX [12]. Our attention to RSR and to its variants is justified by the success of this algorithm, that has been widely used for many applications, e.g. [13] [14] [15].

RSR is the first Retinex implementation that replaces the random path scanning approach with a bi-dimensional random sampling. RSR originated from the need to solve some problems raised up by the use of the random paths. In fact, the path-based sampling mechanism of the original Retinex presents three main disadvantages: first, the color filtering strongly depends on the number and on the geometry of the used paths; second, the randomness of the paths introduces chromatic noise in the estimate of the color sensation; third, in order to reduce this noise, many paths have to be scanned, resulting in long computational times. RSR overcomes these problems by

introducing a novel spatial sampling that explores the region around each image pixel  $x$  with a *random spray*. A random spray is a set of pixels randomly selected from a circular neighbor of  $x$  with a radially decreasing density, accounting for the fact that the pixels closer to  $x$  are more relevant to color sensation than the others [2] [16]. For any spray, the color sensation at  $x$  is computed as the ratio between the intensity of  $x$  and the maximum intensity in the spray. In order to reduce the chromatic noise due to the random sampling, many sprays are generated, and the final color sensation is the average value over the sprays' color sensations. Again, the algorithm precludes division by zero.

STRESS [11] (Spatio-Temporal Retinex-inspired Envelope with Stochastic Sampling) is a variant of RSR, particularly suitable for local contrast stretching, automatic color correction, spatial color gamut mapping, and efficient color to grayscale conversion, e.g. [17] [18]. As RSR, STRESS explores the neighborhood of each image pixel by the use of random sprays, but it estimates the color sensation in a different way. Precisely, for each chromatic channel, and for each image pixel  $x$ , STRESS computes the lightest and the darkest pixel in each spray centered at  $x$  and uses these values to define two functions, said the minimum and the maximum envelope, that contain the chromatic signal. The color sensation at  $x$  is obtained by stretching the chromatic intensities at  $x$  between the corresponding minimum and maximum values in the envelopes.

QBRIX [12] (Quantile-Based approach to RetIneX) is a probabilistic formulation of RSR. It removes the sampling procedure and models the spatial arrangement of the image colors by a suitable distribution function. There are two implementations of QBRIX. The first one is a global filter (here indicated as G-QBRIX), based on the fact that chromatic intensities rarely occurring in the image are not relevant to the color sensation, thus they can be ignored. According to this principle, the probability density function (pdf) of each chromatic channel is computed, and the intensity value corresponding to a quantile, fixed by the user, is set up as reference white. The color sensation is obtained by rescaling the chromatic values of the image by the input quantile that controls the percentage of discarded colors. The second implementation is a local filter (here termed L-QBRIX), that takes into account the spatial distance between the image colors: for each chromatic channel and for each pixel  $x$ , the algorithm computes a *pdf* at  $x$ , where the contribution of each image pixel is weighted by its distance from  $x$ . The color sensation at  $x$  is then computed as in the G-QBRIX. Disregarding the random sampling, QBRIX estimates a color sensation image with a negligible chromatic noise.

The present paper presents a review and a comparative analysis of RSR, STRESS and QBRIX, carried out on a public dataset of color pictures [19] and on some synthetic images usually employed to test color filtering algorithms. We evaluate the performance by means of different measures concerning the capability to enhance the contrast and luminance of the input image, the spatial local properties and the chromatic noise possibly generated by the filtering. The evaluation scheme and the obtained results can be used for the analysis and the comparison of other filtering algorithms.

## 2. Notation

Let  $I$  be a color image with size  $A \times B$ , where  $A, B$  are positive integer numbers. Let  $C_0, C_1, C_2$  be the chromatic channels of  $I$ . Each of them is regarded as a function  $C_i : \text{Supp}(I) \rightarrow [0, 1]$ , where  $\text{Supp}(I)$  is the image support, i.e. the set of the spatial coordinates  $(a, b)$  of the image pixels ( $a \in \{1, \dots, A\}, b \in \{1, \dots, B\}$ ). Here we assume that the chromatic intensities of  $I$ , that in a standard RGB image range over  $\{0, \dots, 255\}$ , have been normalized in  $[0, 1]$ . This assumption is introduced for numerical reasons. Here we refer to the color sensation as to a color image  $I$  defined on  $\text{Supp}(I)$  and having chromatic components  $L_0, L_1, L_2$ .

## 3. Random Spray Retinex

Random Spray Retinex (RSR) [10] is an efficient implementation of Retinex, widely used in many applications. As pointed out in Section 1, RSR was born from the need to decrease the computational cost of Retinex and to partially remove the chromatic noise possibly introduced by the random paths in the estimate of the color sensation. These objectives have been reached by adopting a novel sampling scheme and by simplifying the equation for computing the color sensation. The algorithm works as follows.

For each chromatic channel  $C_i$  and for each pixel  $x \in \text{Supp}(I)$ , with  $C_i(x) \neq 0$ , RSR generates  $N (> 0)$  random sprays centered at  $x$ . The  $k$ th random spray  $S_k(x)$  ( $k = 1, \dots, N$ ) is a set of image pixels  $\{y_k^1, \dots, y_k^M\}$ , belonging to a circular neighborhood centered at  $x$ . The parameters  $N$  and  $M$  are non-null positive numbers and  $M (> 0)$  is smaller or equal to the number of image pixels. The pixel  $y_k^j$  is defined as

$$y_k^j = (x_0 + \rho \cos(\theta), x_1 + \sin(\theta)) \quad (3.1)$$

where  $(x_0, x_1)$  are the spatial coordinates of  $x$ ,  $\rho$  and  $\theta$  are uniformly randomly chosen over the sets  $[0, R]$  and  $[0, 2\pi)$  respectively, and  $R$  is the radius of the spray. Experiments reported in [10] showed that the optimal value for  $R$  is the length of the image diagonal. Fig. 1 shows a random spray centered at the middle point of an image.

The  $i$ th chromatic intensity of the color channel at  $x$  is computed by the following Equation:

$$L_i(x) = \frac{1}{N} \sum_{i=1}^M \frac{C_i(x)}{C_i(x_k)} \quad (3.2)$$

where  $x_k$  is a pixel of  $S_k(x)$  such that

$$C_i(x_k) = \max\{C_i(y) : y \in S_k(x)\}. \quad (3.3)$$

Since we assume that  $S_k(x)$  contains  $x$ , and  $C_i(x) \neq 0$ ,  $C_i(x_k)$  is greater than zero, and thus Equation (3.2) makes sense. When  $C_i(x) = 0$ ,  $L_i(x)$  is set to zero.

The parameters  $N$  and  $M$  control respectively chromatic noise and locality of color filtering. The optimal values of  $N$  and  $M$  depend on the input image and they can be empirically determined as a trade-off between good image quality and computational time [10].



Fig. 1: A random spray centered in the middle of a color image from YACCD. The pixels of a spray are highlighted in red.

### 3. STRESS: Spatio-Temporal Retinex-inspired Envelope with Stochastic Sampling

STRESS (Spatio-Temporal Retinex-inspired Envelope with Stochastic Sampling) [11] inherits from RSR the image exploration mechanism, while it implements a different equation for estimating the color sensation.

For each chromatic channel  $C_i$  and for each pixel  $x \in \text{Supp}(I)$ , with  $C_i(x) \neq 0$ , STRESS computes  $N$  random sprays centered at  $x$ . For each spray  $S_k(x)$  ( $k = 1, \dots, N$ ), it estimates the local reference lightest and darkest chromatic intensities  $E_{min}^k(x)$  and  $E_{max}^k(x)$ , defined as

$$\begin{aligned} E_{min}^k(x) &= \min\{C_i(y) : y \in S_k(x)\}; \\ E_{max}^k(x) &= \max\{C_i(y) : y \in S_k(x)\}. \end{aligned}$$

$E_{min}^k$  and  $E_{max}^k$  can be regarded as two smooth functions, i.e. the *minimum* and *maximum envelopes*, defined from the image support to the chromatic intensities, and containing the entire chromatic channel. Fig. 2 shows an example of such envelopes.

The values  $E_{min}^k(x)$  and  $E_{max}^k(x)$  are used to compute a local chromatic sensation  $v_k(x)$  from  $S_k(x)$  by the following equations:

$$v_k(x) = \begin{cases} \frac{1}{2} & \text{if } R_k(x) = 0 \\ \frac{C_i(x) - E_{min}^k(x)}{R_k(x)} & \text{otherwise} \end{cases} \quad (3.4)$$

where  $R_k(x) = E_{max}^k(x) - E_{min}^k(x)$ .

The final chromatic sensation  $L_i(x)$  is then obtained as

$$L_i(x) = \begin{cases} \frac{1}{2} & \text{if } E_M(x) = E_m(x) \\ \frac{C_i(x) - E_m(x)}{E_M(x) - E_m(x)} & \text{otherwise} \end{cases} \quad (3.5)$$

where

$$R(x) = \frac{1}{N} \sum_{k=1}^N R_k(x); v(x) = \frac{1}{N} \sum_{k=1}^N v_k(x)$$

$$E_m(x) = C_i(x) - R(x)v(x); E_M(x) = E_m(x) + R(x).$$

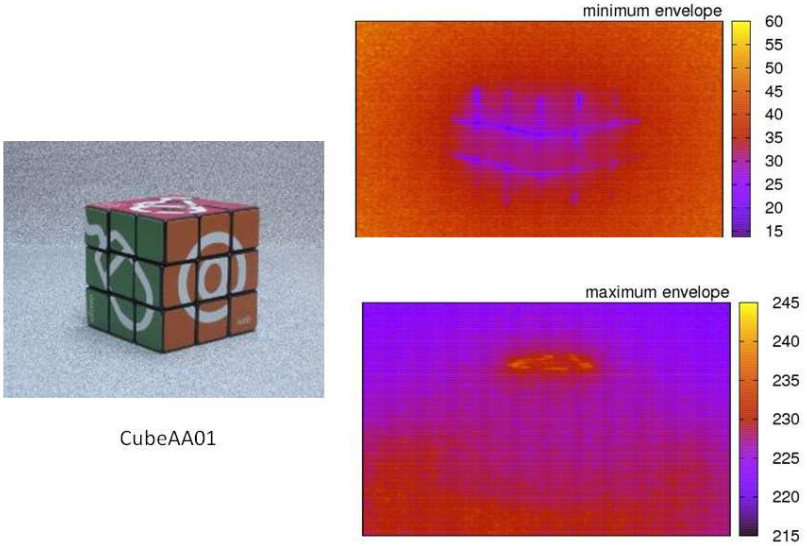

Fig. 2 - The red component of an image from YACCD (CubeAA01) [cite{yaccd2003}] and its minimum and maximum envelopes. These results have been obtained by setting  $N = 35$  and  $M = 125$ .

Using the mean values  $R(x)$  and  $v(x)$  instead of the mean values of  $E_{min}^k(x)$  and  $E_{max}^k(x)$  over the number of sprays emphasizes the weight of the chromatic intensity of the pixels close to  $x$ , and thus produces a less noisy image, with few haloing artifacts [11].

#### 4. QBRIX: Quantile-Based approach to RetIneX

QBRIX (Quantile-Based approach to RetIneX) [12] is a probabilistic version of Retinex, based on RSR. QBRIX relies on the observation that the color sensation at any image pixel  $x$  is poorly influenced by (1) colors rarely occurring in the image and (2) colors of pixel located far from  $x$ . The observation (1) leads to an implementation of a global color filter, named G-QBRIX, while merging both (1) and (2) leads to a local color filter, named L-QBRIX. Both these versions process the chromatic channels separately and replace the random sampling of RSR with a statistic approach that suppresses the chromatic noise that in RSR is due to the random sampling.

#### 4.1. The Global Filter: G-QBRIX

For each chromatic channel, G-QBRIX computes the probability density function (pdf) of the chromatic intensities. Due to the discrete nature of the data, the pdf is approximated by a histogram, normalized so that it sums up to 1.0. The pdf of a certain chromatic value  $C$  is thus computed as

$$p(C) = \frac{\#\{y \in \text{Supp}(I), y : C_i(y) = C\}}{\#\{y \in \{\text{Supp}(I)\}} \quad (4.1)$$

G-QBRIX is grounded in the observation that chromatic intensities rarely occurring are irrelevant to color sensation, regardless of their values. The observation holds for the highest luminance pixels which are to be used as reference white values: as a consequence G-QBRIX considers only a certain percentage of image pixels, corresponding to a quantile  $Q$  of the pdf  $p$ . We remind that the quantile  $Q$  of the pdf  $p$  is a real number ranging over  $[0, 1]$  that partitions  $p$  in two parts at a chromatic intensity  $q$  such that  $\sum_{z=0}^q p(z) = Q$ .

The value of  $Q$  is a user input and controls the percentage of pixels to be disregarded: more precisely, the percentage of retained pixels is the  $(100 \cdot Q)\%$ . The value of  $L_i(x)$  (where as usual  $x$  is an image pixel) is given by the following equation:

$$L_i(x) = \begin{cases} 0 & \text{if } C_i(x) = 0 \\ 1 & \text{if } C_i(x) > q, C_i(x) \neq 0 \\ \frac{C_i(x)}{q} & \text{otherwise} \end{cases} \quad (4.2)$$

The second condition defines the chromatic sensation when  $q$  is smaller than the value of  $C_i(x)$ . For instance, this is the case of an image with  $C_i(x) = 1$  and a low value of  $p(C_i(x))$ .

#### 4.2. The Local Filter: L-QBRIX

L-QBRIX re-implements the procedure of G-QBRIX by taking into account also the influence of the spatial arrangement of the colors in the image. For each chromatic channel  $C_i$  and for each pixel  $x$  in the image support, the algorithm computes a pdf of the chromatic intensities at  $x$ , such that

$$p_x(C) = \frac{1}{W} \sum_{y \in \{\text{Supp}(I) \setminus \{x\}, C_i(y)=C\}} \left[ \frac{d(x, y)}{D} \right]^{-\alpha} \quad (4.3)$$

In this equation,  $d(x, y)$  denotes the Euclidean distance between  $x$  and  $y$ ,  $D$  is the length of the image diagonal, the parameter  $\alpha$  is a real number tuning the relevance of the distance in the color sensation, and  $W = \sum_A p_x(A)$  is a normalization factor where  $A$  ranges over the possible chromaticity intensities.

As in G-QBRIX, also in L-QBRIX the chromatic sensation  $L_i(x)$  is computed by selecting a quantile of the pdf  $p_x(C)$  and by applying Equation (4.2).

## 5. Experiments

The color sensation output by the Retinex algorithms is an enhanced color image, where the chromatic dominant of the light and possible slight shadows are partially removed and the scene details are emphasized. In our comparative analysis of RSR, STRESS and QBRIX, we define a set of evaluation measures taking into account three visual properties of the color sensation, already used in previous works, e.g. [20] [9]: brightness, contrast, chromatic dynamic range. The analysis of these quantities allow to evaluate the image enhancement produced by the algorithms of the Retinex family. We remark that here we do not consider any pre- or post-filtering calibration of the input and output images, which is usually required by other tasks, e.g. for modeling the human vision system [21].

The proposed comparison is performed on the public dataset YACCD [19] that is composed by 168 pictures displaying seven objects portrayed against two textured backgrounds and under seven illuminants with and without shadows (see Fig. 3 for an example). The tests have been also performed on a simple image, named Test16.255, displaying a bright square (with uniform RGB color (255, 255, 255)) over a dark background (with uniform RGB color (16, 16, 16)). Due to its simple structure (see Fig. 4(a)), Test16.255 is commonly employed to visualize the filtering effects of spatial color algorithms.



Fig. 3 - An example from YACCD: (A) the same image has been captured under seven different illuminants; (B) for each illuminant, the object is displayed against two different backgrounds, with and without shadows.

### 5.1. Evaluation Measures

**Brightness** - We evaluate the brightness variation between the input image  $I$  and its color filtered version  $I_c$  by comparing their brightness mean values. Precisely, the mean image brightness is defined as

$$\mu = \frac{1}{\#\{y \in \text{Supp}(I)\}} \sum_{y \in \text{Supp}(I)} (B_0(y) + B_1(y) + B_2(y)) \quad (5.1)$$

where  $\text{Supp}(I)$  indicates the set of the image pixels, and for any  $i = 0, 1, 2$ ,  $B_i$  indicates the chromatic values of the input image (i.e.  $B_i = C_i$ ) or of a filtered version (i.e.  $B_i = L_i$ ).

**Contrast** – We evaluate the improvement of the details visibility by comparing the mean value of a multi-resolution contrast of the brightness of  $I$  and  $I_s$ , as proposed in [22], which accounts for local chromatic intensity variations at different scales. The contrast measure is defined operatively by constructing a pyramid of  $H$  images  $I_0, \dots, I_{H-1}$  (with  $H$  an integer positive number) where  $I_0$  is the brightness of  $I$  and for each  $h = 1, \dots, H - 1$ ,  $I_h$  is the image  $I_{h-1}$  rescaled by 0.5. For each image  $I_h$  we evaluate the  $h$ th local contrast at a pixel  $y \in \text{Supp}(I_h)$

$$c_h(y) = \frac{1}{8} \sum_{z \in N_8(y)} |I_h(z) - I(y)|$$

where  $N_8(y)$  denotes the 8-connected neighborhood of  $y$ . The global contrast  $\bar{c}_h$  of  $I_h$  is then obtained as the mean values of  $c_k$  over the number of pixels of  $I_h$ , i.e.

$$\bar{c}_h = \frac{1}{\#\{y \in \text{Supp}(I_h)\}} c_k(y).$$

The global contrast of  $I$  is then obtained by averaging the values  $c_h$  over  $h$ :

$$C = \frac{1}{H} \sum_{h=0}^{H-1} \bar{c}_h. \quad (5.2)$$

**Histogram Flatness** - The brightness and contrast enhancement of the Retinex algorithms modifies the shape of the pdfs of the chromaticity image channels. Precisely, the divisions performed by RSR, STRESS and QBRIX stretch the pdf of the brightness of the input image. We quantify this effect by computing the flatness  $F$  of the pdf. Flatness is defined as the  $L^1$  distance of the pdf  $p$  of the image brightness from an uniform pdf [23].

## 5.2. Results

Fig. 4 shows the filtering results obtained on the image Test16.255. These results have been obtained by using  $N = 15$  and  $M = 200$  for RSR and STRESS. As highlighted by the histogram equalizations in (f) and (g), the results obtained by using RSR and STRESS are noisy because of the random sampling.

Tab. 1 reports the values of the evaluation measures listed in Section 6.1 for the database YACCD. In these experiments, in order to reduce the computational time, we rescaled the YACCD images by 0.25, so that the size of the images considered here is 250 x 200 pixels. The parameters  $N$  and  $M$  input to RSR vary from image to image. They have been set up as suggested in [10]: each image has been processed with different increasing values of  $N$  and  $M$ , then we chose as final filtering the



picture such that the CIELab difference between two subsequent filtering gets smaller than a fixed threshold. More details about the parameter set up for this dataset are provided in [20]. The pairs  $(N, M)$  used for RSR have been used also for STRESS. In QBRIX, we report the results obtained by setting  $Q = 0.99$ .

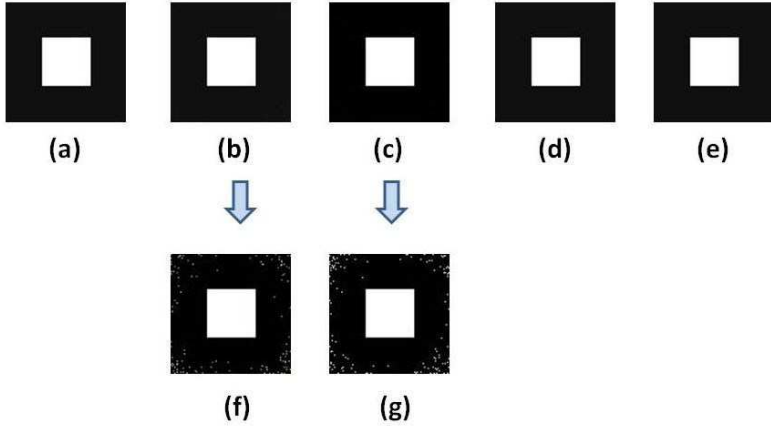

Fig. 4 - Image Test16.255, and its filtered versions with (b) RSR; (c) STRESS; (d) G-QBRIX; (e) L-QBRIX). Visually the images look equal. Equalizing the histogram does not change the images (a), (d), (e) while the images (b) and (c) change: figures (f) and (g) show the chromatic noise added by the filtering process to (b) and (c) respectively.

ALGORITHM	MEAN LUMINANCE ( $\mu$ )	MULTI-RESOLUTION CONTRAST ( $C$ )	FLATNESS [ $\times 10^{-3}$ ] ( $F$ )
NONE	113.31	23.32	3.48
RSR	138.09	28.75	2.82
STRESS	126.40	32.04	2.44
G-QBRIX	138.01	28.70	2.79
L-QBRIX	143.57	30.00	2.84

Tab. 1 - Results on YACCD.

All the considered algorithms output an enhanced image, with increased luminance and contrast, while the histogram flatness diminishes, meaning that the filtering widens the dynamic range of the chromatic intensities. On average, the results obtained by RSR and G-QBRIX are very similar. STRESS outputs images with a lower brightness and with a higher contrast than the other algorithms. L-QBRIX produces the brightest pictures.

Two examples of the color filtered images obtained by RSR, STRESS and the two versions of QBRIX are shown in Fig. 5 and Fig. 6. Precisely, Fig. 5 shows the results on an image captured under an illuminant simulating the natural daylight with a correlated color temperature of 6500K; Fig. 6 shows the results on an image taken under a light with a considerable red component, and reports the color filtering results obtained by running QBRIX with two different values of the quantile  $Q$ . The results

obtained with the highest quantile ( $Q = 0.99$ ) are closer to those output by RSR and STRESS. We remark that L-QBRIX may produce a halo around the object borders: this is due to the spatial locality of the algorithm. In general, for a very low value of  $Q$ , many pixels satisfy the second condition of Equation (4.2), thus the algorithm provides a too bright image, where many details are lost. When  $Q = 1$ , G-QBRIX behaves like scale-by-max, while L-QBRIX realizes a local effect, where the pixels' intensity is weighted by the spatial distance of the max.

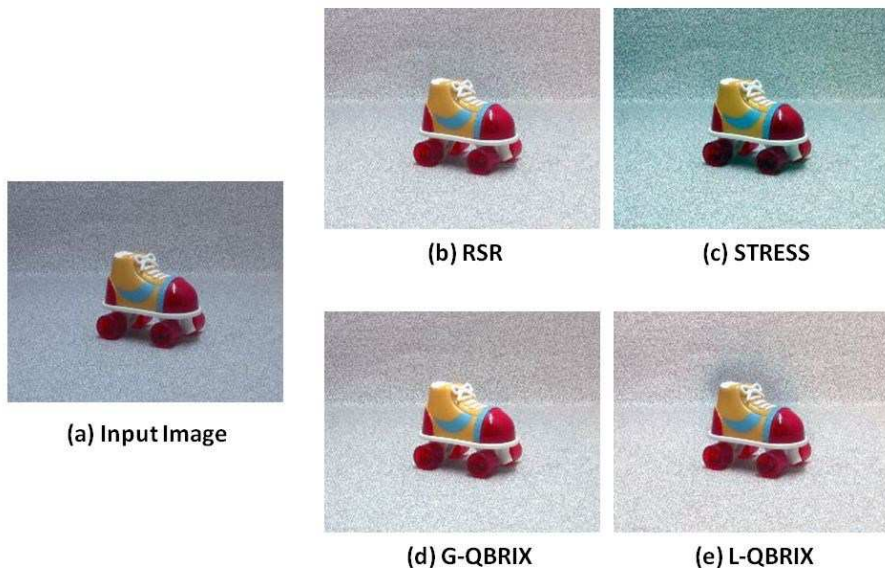

Fig. 5 - (a) An image from YACCD and its filtered versions with (b) RSR; (c) STRESS; (d) G-QBRIX; (e) L-QBRIX.

## 6. Conclusions

In this paper we have reviewed and compared three Retinex implementations: RSR, and its variants STRESS and QBRIX. RSR and STRESS share the same spatial sampling strategy, performed by random points, while they differ from each other for the mathematical equation used to compute the color sensation. QBRIX reformulates RSR in a probabilistic framework that avoids the random sampling, and performs color correction by considering the statistic distribution of the image chromatic channels.

We have compared these methods by measuring their image enhancement capability on the public color database, YACCD that contains the pictures of six objects acquired under seven different lights, with and without shadows, and with two different background.

The experiments show that all these methods enhance the input image by producing an image with higher brightness and contrast, and with a better use of the available dynamic range.

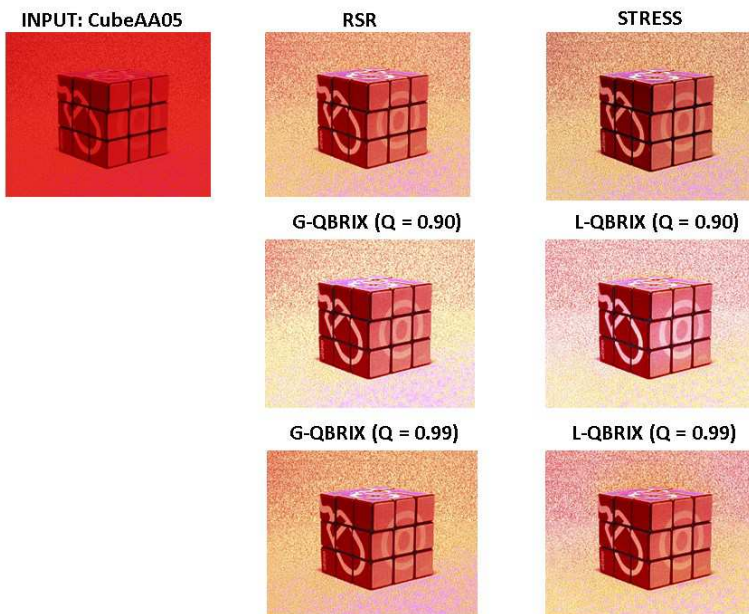

Fig. 6 - Results of RSR, STRESS and QBRIX for two different values of the quantile.

## Acknowledgements

This work has been partially granted by Università degli Studi di Milano, Piano di Sostegno alla Ricerca 2015/2017, Linea 2, Discovering Patterns in Multi-Dimensional Data.

## Bibliography

- [1] J. Albers, *Interaction of Color*, Yale University Press, 2006.
- [2] J. McCann and A. Rizzi, *The Art and Science of HDR Imaging*, John Wiley, 2011.
- [3] R. de Valois and K. de Valois, *Spatial Vision*, Oxford Psychology Series 14, 1990.
- [4] E. H. Land and J. a. J. McCann, "Lightness and Retinex Theory," *Journal of the Optical Society of America*, vol. 11, 1971.
- [5] E. Provenzi, L. D. Carli, A. Rizzi and D. Marini, "Mathematical definition and analysis of the Retinex algorithm," *Journal of the Optical Society of America A: Optics and Image Science, and Vision*, vol. 22, no. 12, 2005.
- [6] D. Marini and A. Rizzi, "A computational approach to color adaptation effects," *Image and Vision Computing*, vol. 18, no. 13, pp. 1005-1014, 2000.
- [7] R. Montagna and G. D. Finlayson, "Constrained pseudo-Brownian motion and its application to image enhancement," *J. Opt. Soc. Am. A*, vol. 28, no. 8, 2011.

- [8] G. Simone, G. Audino, I. Farup, F. Albreghsen and A. Rizzi, "Termite retinex: a new implementation based on a colony of intelligent agents.," *J. Electron. Imaging*, vol. 23, no. 1, 2013.
- [9] M. Lecca, A. Rizzi and G. Gianini, "Energy-driven path search for Termite Retinex.," *J. of the Optical Society of America A*, vol. 33, no. 1, 2016.
- [10] E. Provenzi, M. Fierro, A. Rizzi, L. De Carli, D. Gadia and D. Marini, "Random Spray Retinex: A New Retinex Implementation to Investigate the Local Properties of the Model," *Image Processing, IEEE Transactions on*, vol. 16, no. 1, pp. 162,171, 2007.
- [11] O. Kolas, I. Farup and A. Rizzi, "Spatio-Temporal Retinex-inspired Envelope with Stochastic Sampling: A framework for spatial color algorithms," *Journal of Imaging Science and Technology*, vol. 55, no. 4, 2011.
- [12] G. Gianini, A. Manenti and A. Rizzi, "QBRIX: a quantile-based approach to Retinex," *J. Opt. Soc. Am. A*, vol. 31, no. 12, 2014.
- [13] A. Rizzi and C. Parraman, "Developments in the recovery of colour in fine art prints using spatial image processing," *Journal of physics. Conference series*, vol. 231, no. 1, 2010.
- [14] M. Fierro, W.-J. Kyung and Y.-H. Ha, "Dual-tree Complex Wavelet Transform based denoising for Random," in *Conference on Colour in Graphics, Imaging, and Vision*, 2012.
- [15] N. Loncaric and S. Banic, "Using the Random Sprays Retinex algorithm for global illumination estimation," in *Proceedings of the Croatian Computer Vision Workshop*, 2013.
- [16] O. Creutzfeldt, B. Lange-Malecki and K. Wortmann, "Darkness induction, Retinex and cooperative mechanisms in vision," *Experimental Brain Research*, vol. 67, no. 2, 1987.
- [17] A. Tariqul Islam and I. Farup, "Enhancing the output of spatial color algorithms," in *Visual Information Processing (EUVIP), 2010 2nd European Workshop on*, 2010.
- [18] A. B. M. T. Islam and I. Farup, "Spatio-temporal colour correction of strongly degraded movies," in *Proc. SPIE*, 2011.
- [19] A. Rizzi, C. Gatta and D. Marini, "YACCD Yet another color constancy database," in *Proceedings of SPIE - The International Society for Optical Engineering*, 2003.
- [20] M. Lecca and A. Rizzi, "Tuning the locality of filtering with a spatially weighted implementation of random spray Retinex," *J. of Optical Society of America A*, vol. 32, no. 10, 2015.
- [21] A. Rizzi and J.-J. McCann, "On the behavior of spatial models of color," in *Proceedings of SPIE - The International Society for Optical Engineering*, 2007.
- [22] A. Rizzi, T. Algeri, G. Medeghini and D. Marini, "A proposal for contrast measure in digital images," in *CGIV 2004 - Second European Conference on Color in Graphics, Imaging, and Vision and Sixth International Symposium on Multispectral Color Science*, 2004.
- [23] A. Rizzi, C. Gatta and D. Marini, "A New Algorithm for Unsupervised Global and Local Color Correction," *Pattern Recogn. Lett.*, vol. 24, no. 11, 2003.
- [24] A. Rizzi, D. Marini and L. De Carli, "LUT and Multilevel Brownian Retinex Colour Correction," *MG & V*, vol. 11, 2002.
- [25] M. Lecca, A. Rizzi and G. Gianini, "Energy-driven path search for Termite Retinex.," *J. of Optical Society of America A*, vol. 33, no. 1, 2016.

# A technique to ensure color fidelity in automatic photogrammetry

<sup>1</sup>Marco Gaiani, <sup>1</sup>Fabrizio Ivan Apollonio, <sup>1</sup>Andrea Ballabeni, <sup>2</sup>Fabio Remondino

<sup>1</sup>Dip. Architettura, Università di Bologna, marco.gaiani | fabrizio.apollonio | andrea.ballabeni@unibo.it

<sup>2</sup>3D Optical Metrology (3DOM) Unit, Bruno Kessler Foundation, remondino@fbk.eu

## 1. Introduction

In 2013 we presented a new process and some solutions for color acquisition, management, rendering and assessment for the generation of Architectural Heritage (AH) 3D models from images [1]. The aim was to illustrate easy, low-cost and rapid procedures to produce high radiometrically correct images/models while being accessible to non-specialized users and unskilled operators - typically heritage architects. The solution was successfully tested on the 3D digitization of 10 kilometers of historical porticoes but its applicability demonstrated some bottlenecks mainly due to the lack of automation in many steps.

In the last years, the pipeline for 3D reconstruction using image-based techniques is increasingly becoming a key approach, ensuring ease of use and efficient results, even for non-professional [2]. Significant progress has been recently achieved in all core components of the image-based pipeline. Unfortunately, very few developments have been done for the problem of accurate color reproduction using automated processes.

Nowadays the problem of an accurate color description and reproduction using images could be depicted as the problem of faithfully determine the color and tone level and can be solved by the chromatic and tonal definition [3]. The fidelity of color reproduction depends on a number of variables such as the lighting level during the acquisition step, the technical characteristics of the acquisition system, and the mathematical representation of color information throughout the acquisition and reproduction pipeline. In particular, the values of a color in an image are the result of the interaction of the incident illumination, the object geometry, the object reflectance, the lens and the camera transfer function. In general, the solution of this problem requires understanding and controlling environmental and artificial light sources during the image acquisition phase. When illumination is reliably known, parameters for a surface reflectance function can be estimated using the image values [4].

AH artifacts implies outdoor environments, where natural light characteristics are extremely complex and changeable. Scenes are characterized by flat, textureless and curved surfaces reacting to light in several ways. The wide range of materials lead to different values of light reflection, porosity, etc. These difficulties increase when the problem of chromatic and tonal reproduction is addressed to the context of reality-based 3D modeling and visualization [5].

We could summarize the problem from the acquisition point of view stating that the capture-to-render image processing pipeline is a crucial step to ensure color fidelity and consistency of correct measurement. Furthermore, the quality of the acquired and used images is becoming fundamental to allow automated methods of doing their tasks correctly. Motion blur, sensor noise, jpeg artifacts, wrong depth of field are just some of the possible problems that are negatively affecting automated 3D reconstruction methods. These problems are then coupled with lack of texture scenarios, repeated patterns, illumination changes, etc. Therefore, image pre-processing methods

are fundamental to improve the image quality for successful photogrammetric processing [6]. Finally, a typical image dataset of an AH object consists in a series of acquisitions observing the object through several viewing angles with some problems: not all images could contain a color chart (colorimetric calibration not accurate); not all image areas are lighted uniformly (radiometric values can differ).

This paper presents an efficient and automated image pre-processing methodology developed to increase the processing performances of the two central steps of the photogrammetric pipeline (image orientation and dense image matching), and simultaneously radiometrically improve the quality of an image datasets to accurately reproduce the correct colors of the surveyed AH. The proposed methodology aims to achieve a robust automatic color balance and exposure equalization to ensure (i) faithful color appearance of a digitized artifact and (ii) improvements in both sparse and dense 3D reconstruction in the photogrammetric process. The solution is completely automated and can be easily integrated in any processing workflow as it consists in pre-processing the images used to define colors and shape. The output result is a set of color-calibrated images.

We move then in the well-delineated context in which authors [7] demonstrated that a preprocessing approach for RAW imagery can yield significant photogrammetric accuracy improvements over those obtained with JPEG. RAW files are intentionally inscrutable data structures, but have been reverse engineered with some success to gain access to the raw data inside [8]. In our consideration, only the basic in-camera processing was retained: black point subtraction; bad pixel removal; dark frame, bias subtraction & flat-field correction; green channel equilibrium correction; Bayer interpolation. To avoid uncontrolled modification of the RAW pixel intensity values we did not allow these on-camera processes: denoising; color scaling; image sharpening; color space conversion; Gamma correction; format conversion.

A software exploiting Xrite ColorChecker Classic was developed and tests were performed to demonstrate the efficiency of our process in different situations. Color accuracy ('color characterization') was evaluated and expressed. Finally, we evaluate the consistency of our color pipeline compared to image-based reconstruction procedure in three contexts: image matching, image orientation, and semi-global matching.



Fig. 1 – A result of the developed workflow.

## 2. Camera radiometric calibration & color space transformation

A digital image captured with a digital camera is formed by the intensity values of the RGB channels. Each of these values is influenced by three physical characteristics: (i) source of light (also called illuminant), (ii) object reflectance or transmittance and (iii) sensor spectral response (combination of spectral characteristics of colorants used in the Bayer filter and spectral sensitivity of the photodetectors). The image values  $f_c = (f_R, f_G, f_B)$  depend on the color of the light source  $I(\lambda)$ , the surface reflectance  $S(x, \lambda)$  and the camera sensitivity function  $\rho_c(\lambda) = (\rho_R(\lambda), \rho_G(\lambda), \rho_B(\lambda))$ , where  $\lambda$  is the wavelength of the light and  $x$  is the spatial coordinate [9, 10]:

$$f_c(x) = m_b(x) \int_{\omega} I(\lambda) \rho_c(\lambda) S(x, \lambda) d\lambda + m_s(x) \int_{\omega} I(\lambda) \rho_c d\lambda \quad (1)$$

where  $c = \{R, G, B\}$ ,  $\omega$  is the visible spectrum, and  $m_b$  and  $m_s$  are scale factors that model the relative amount of body and specular reflectance that contribute to the overall light reflected at location  $x$ . Under the Lambertian assumption the specular reflection is ignored. This results in the following model:

$$f_c(x) = m(x) \int_{\omega} I(\lambda) \rho_c(\lambda) S(x, \lambda) d\lambda \quad (2)$$

where  $m(x)$  is Lambertian shading. It is assumed that the scene is illuminated by one single light source and that the observed color  $e$  depends on the color of the light source  $I(\lambda)$  as well as on the camera sensitivity function  $\rho(\lambda)$ :

$$e = \begin{pmatrix} e_R \\ e_G \\ e_B \end{pmatrix} = \int_{\omega} I(\lambda) \rho(\lambda) d\lambda \quad (3)$$

Without prior knowledge, both  $I(\lambda)$  and  $\rho(\lambda)$  are unknown and hence the estimation of  $e$  is an ill-posed problem that cannot be solved without further assumptions. In particular cameras use a finite set of sensor responses, obtained by spectral integration [11], to describe the continuous light spectrum. Imaging sensors vary widely with the characteristics of the camera and different cameras usually produce different values. There exist several computational camera calibration models that estimate the sensitivity functions of the camera [12, 13]. Given an estimate of the sensitivity function of a camera and standard sensitivity function, there exists a 3x3 transformation matrix  $S_{Sen}$  converts theoretical responses for standard sensors into those of the actual camera [14]. If  $p^s$  is the vector whose standard coordinates are  $p_k^s$  and  $p$  denotes the response of the camera whose coordinates are  $p_k$ , we have:  $p = S_{Sen} p^s$ .

For digital images, color characterization methods refer to the techniques of converting camera responses (e.g. RGB) to a device-independent colorimetric representation (e.g. CIEXYZ) [15, 16]. The main problem consists in recovering a linear relationship between the irradiance values and the pixel encoding produced by the camera, typically non-linear. We need therefore to model the non-linearities introduced by in-camera processing for enhancing the visual quality of recorded images.

The availability of RAW data from current SLR cameras removes any extra and unwanted processes (e.g., white balance and gamma correction). This help to provide a linear relationship to scene radiance and to obtain device-independent images that can be quantitatively compared without knowledge of the original imaging system [17]. Models that approximate raw (linear) RGB from nonlinear RGB images (e.g., sRGB)

exist, but they require a series of training images taken under different settings and light conditions as ground-truth raw images [18].

The problem of ‘color characterization’ is usually solved determining the non-linear camera response function from observations. It can be based on multiple images taken with different exposure times from a fixed camera location [19, 20], color distribution analyses around image edges [21], or color profiles obtained from varying lightings [22]. In all of these cases, recovering radiometric response functions without additional knowledge or assumptions is an ill-posed problem.

Basically, color characterization methods are divided into two general categories in the literature: spectral sensitivity-based and color target-based approaches, as specified by ISO17321.14 [23]. The spectral sensitivity-based methods connect device-dependent and device-independent color spaces by a linear combination of camera spectral sensitivity curves and color matching functions [24-26]. On the other hand, the target-based characterization methods establish the color relationship according to a set of color patches with available pre-measured spectral or colorimetric data [27]. These latter methods are valid for a particular lighting geometry, color target materials and surface structure. Therefore, it is recommended to keep the viewing/illuminating geometry consistent with the measurement geometry and typical observing conditions [28] while capturing a digital image of a target. One common reference useful for target-based characterization techniques is the target X-Rite ColorChecker Classic [29], which has standardized patches with known reflectance.

The most precise calibration for any given camera requires recording its output for all possible stimuli and comparing it with separately measured values for the same stimuli [30]. The responses to these representative stimuli can then be used to calibrate the device for input stimuli that were not measured, finding the transformation between measured CIEXYZ values and captured RGB values. A complete review of these techniques is given in [3].

In most of the proposed methods, camera responses are required to be RAW data and already corrected for non-linearity, dark current and optical flare. In many cases, a simple linear transformation is sufficient to map device-dependent and device-independent spaces with adequate performance although higher-order polynomials have reported better estimations [31].

After camera radiometric a conversion of image colorimetric coordinates in a scene-referred non-linear color space as sRGB, AdobeRGB (1998) to be used in the photogrammetric pipeline [32], is done. In particular, sRGB IEC 61966-2-1 is a default color space for multimedia application [33] with the white-point at 6500K temperature (D65). The sRGB is consistent from color capture with different acquisition devices (scanner and cameras), to visualization by different devices and is incorporated by the two dominant programming interfaces for 3D graphics, OpenGL and Microsoft Direct3D. Main drawback is the gamma built inside that cannot be expressed as a single numerical value. The overall gamma is approximately 2.2, but it consists of a linear (gamma 1.0) section near black, and a non-linear section elsewhere involving a 2.4 exponent and a gamma changing from 1.0 through about 2.3. A second drawback is the range of colors, narrower than that of human perception (i.e., it does not display properly saturated colors such as yellow cadmium and blue cobalt). This last downside is not a problem in our case, because misrepresented colors are rarely found.



### 3. Target detection

In the camera characterization techniques based on color targets, the targets placed in the scene are usually manually or semi-automatically localized to extract color values of chart patches. When dealing with large image datasets the target localization can be lengthy and tedious. Automatic target detection is then an important feature and become a needed requirement in automated processing pipelines.

Currently only few proposals exist addressing automatic color target detection.

In [34] a semi-automatic method focusing on images with a significant degree of distortion is introduced. The presented technique requires an operator to select the four corners of the chart. On this basis, the coordinates of color patches are estimated using projective geometry. The essence of this method is a multi-stage color patch detection where the image is transformed with a Sobel kernel, a morphological operator and thresholding into a binary image and find connected regions. The technique is not suitable for our uses, requiring an operator.

[35] introduce a real-time automatic color target detection procedure extracting polygonal image regions and applying a cost function to check adaptation to a color chart. The color chart model is described by coordinates and color values of chart patches. In order to find the chart coordinates in image, four corners of chart model are projected on image with the use of a Direct Linear Transformation (DLT). Coordinates of color chart are found and a cost function measures the colors of the chart in the image and determines correction parameters. The technique is fast and robust against image noise, blur and other typical distortions, but using image region statistics fail when color target is very small in the imaged scene.

[36] uses image binarization and patch grouping to construct bounding parallelograms, then applies heuristics to try to determine the types of color charts.

[37] focuses on multi-color object detection with cluttered backgrounds and variable illumination for a target application to color chart detection. They adopt a coarse-to-fine strategy to predict the chart location and recover its topological structure, e.g. the position and boundary of each constituent color area. A per-channel feature extraction with a sliding rectangle, fed into a rough detection step with predefined 2x2 color patch templates, followed by precise detection.

A different class of solution aims to simply locate the color target in the image rather than detect it. In [38] authors present an automatic ColorChecker detection technique where the algorithm first quantizes all colors to those in the color chart, then performs connected component analysis with heuristics to locate patch candidates, which are then fed to a Delaunay triangulation which is pruned to find the final candidate patches and finally determine the orientation of the chart. The method is based on the fact that there are low perspective distortions, the scanning resolution is known and the lighting is approximately constant in the image.

A more general approach was considered in the method proposed by [39], who used color descriptors to automatically locate the color reference target. SIFT feature matching and then clusters matched features are fed into a pose selection and appearance validation algorithm. The method is robust to varying illumination conditions, but it is complex and presents the typical limits of SIFT technique.

Commercial software is also capable of doing a semi-automatic color reference target detection. Examples are the X-Rite ColorChecker Passport Camera Calibration Software [40], which tries to perform an initial automatic detection, Imatest [41] and BabelColor PatchTool [42]. Every software however usually relies on human intervention to manually mark or correct the detected reference target.

Freely available tools also exist. The most interesting for our applications are MacDuff [43] and CCFind [44], both aiming at detecting the ColorChecker Classic inside an image. MacDuff, exploiting some code from OpenCV, handles the case of images with an X-Rite ColorChecker Passport. The solution uses adaptive thresholding followed by contour finding with heuristics to try to filter down to ColorChecker squares, then using k-means clustering to cluster squares. The average values of colors of square patches are then computed and a recursive process based on Euclidean distance in RGB space minimization try to find if any layout/orientation of square clusters would match ColorChecker reference values. The software assumes that the ColorChecker occupies a relatively large portion of the input image. CCFind is a method implemented in MATLAB specifically designed not to use color as a cue. CCFind does not detect squares explicitly. Instead, it learns the recurring shapes inside an image. It's a solution shape-based robust to illumination changes and perspective distortion, returning the coordinates of the center points of the color patches of a X-Rite ColorChecker. The main limitation is the difficulty to find ColorCheckers, relatively small within the image, or those that are close to the image borders. [45] implements a preprocessing step for finding an approximate region of interest (ROI) of an X-Rite ColorChecker, and apply it to both CCFind and a template matching approach. The algorithm uses a texture transformation to better differentiate the reference target region from the rest of the image (i.e. to enhance its contrast). Then it creates a saliency map by using region and color information, and a threshold is used to create a binary mask of this saliency map. A ROI is finally determined by applying morphological operations to the resultant mask. The experiments show that the algorithm improves both detection and computation time by reducing the search area, but further improvements are needed to use it in a fully automated workflow.

From this quick review we could observe that main difficulties in color target detection are (i) a deformation of shape of target and (ii) a small size of chart in the image. The deformation of shape of color target is connected with orientation and location of chart in the image. Distortions are made by location of color chart, not rigid material of color chart and camera optics. Influence on the proper detection have also the light conditions. The ambient light causes changes in the color values and high color variations due to non-uniformity that could affect color-based techniques. Given this consideration and the typical scenarios of our work, a new approach was developed.

#### **4. Developed methodology**

In this section we present a method that, integrating ICC-based color management and target-based color balance, aims to acquire the color of the measured AH artifact with perceptive fidelity.

The aim of our color pre-processing consist essentially in obtaining radiometric calibrated images able to ensure the consistency and fidelity of surfaces colors reproduction throughout photogrammetric pipeline.

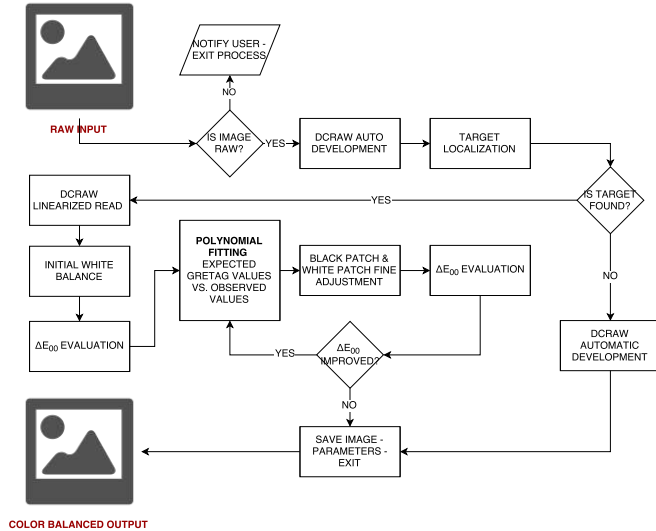

Fig. 2 – Developed workflow.

Lying between the two main color correction approaches (color characterization spectral sensitivities based vs. color targets based), we adopted a technique that uses a set of differently colored samples measured with a spectrophotometer, taking as target the popular and consistent X-Rite ColorChecker Classic. We simplified the whole calibration procedure exploiting the observation that all the shots of a specific scene are taken in very short time (few minutes) and with similar point of view and camera direction, while illumination and camera parameters remain practically unchanged. We then used a calibration strategy referred to that specific scene and illumination, allowing us to avoid to take multiple image with different exposures.

A captured color image containing the reference chart color is neutralized, balanced and properly exposed for the gamma of the reference data set. Since two shots cannot be taken in the same frame (i.e., shots with and without the ColorChecker) we developed a protocol to use the same calibration for groups of images with the same features (i.e., orientation, exposure, framed surfaces). Thus, each group of photos (50-100 images) used to model a building correspond to less than 4-5 different profiles, thereby maintaining consistency in the process and the results.

From an operational point of view, the preservation of color fidelity throughout the image processing is ensured, as in our manual pipeline, by:

- taking pictures in the most homogeneous operative conditions possible (aperture/exposure direction and intensity of light);
- including ColorChecker target inside the photographed scenes in order to correct the image radiometry;
- storing photos in RAW format;
- using an appropriate color space throughout the image processing.

An important and critical issue is the acquisition of the color target. In order to maintain uniform lighting in an external environment, for each image, we need to consider: (i) surfaces illuminated and oriented as the ColorChecker and that presents an angle of incidence with sunlight of approximately 20-45 degrees or (ii) image acquisitions

performed with overcast sky. To minimize the light glare, that would give unexpected results in the calibration process, the ColorChecker is normally placed on a tripod with a dark background and orthogonal to the camera optical axis. Other practical issues affecting the quality of calibration (e.g. position of the target far from the photo center point, size of the target in the image) are minimized by a new automatic detection technique able to find target of different size and in different position in the image.

Our color processing essentially consists of a thoughtful revision of a classic pipeline of image radiometric calibration and enhancement using standardized methods and on the basis of appropriate best practices, to ensure color consistency, in a new automatic workflow. The steps are performed automatically with a new application written in MATLAB language. Basically the developed software solution is a RAW image processing implemented in MATLAB and supported by DCRaw, an open-source command-line program, easily coupled with MATLAB [46], allowing image demosaicing, white balance, output file in a rendered color space, gamma correction, brightness control, 8-bit/16-bit conversion. Our automatic workflow is as follows (Fig. 2):

1. RAW image 16-bit linearization
2. ColorChecker localization
3. Polynomial fitting of observed ColorChecker values with expected values
4. Image correction using the fitting function found at point 3.
5. White balance of the correct image
6.  $\Delta E^*_{00}$  mean error evaluation on the ColorChecker 24 patches
7. Iterative image correction using the fitting function found at point 3 increasing the degree of the polynomial at each step; iteration stops when  $\Delta E^*_{00}$  stops decreasing
8. Image correction using the new fitting function.

In this process a key-point is the use of an appropriate color space for the output images. Our final color space (the output referred color space) is sRGB, a choice motivated by many reasons: sRGB is the default color space for HTML, CSS, SMIL and other web standards; it is consistent among different monitors or video-projectors; it is implemented in the OpenGL graphic libraries, which the rendering software is based on [47]. As reference, we used the 8-bit sRGB color spaces by [48].

Main features of our software are as follows:

- a. *ColorChecker detection*. We improved the [49] solution correcting the failures when the target was too near to the observer. The algorithm, if it does not find the target at first attempt, resize the image increasingly and adds a frame of white noise around it, to keep the initial size. After that the target was found in the image resized, coordinates are bringing back on the original ones.
- b. *RAW image linearization* to CIEXYZ color space and 16-bit encoding to work without missing information.
- c. *Polynomial fitting* of image values. This step aims to minimize the difference between measured colors and image colors by converting linear CIEXYZ colors to a standard, device-independent space. The transformation is achieved using a per-channel Polynomial curve fitting algorithm. Polyfit (x,y,n) returns the coefficients for a polynomial  $p(x)$  of degree n that is a best fit (in a least-squares sense) for the data in y. The coefficients in p are in descending powers, and the length of p is n+1:

$$p(x) = p_1x^n + p_2x^{n-1} + \dots + p_nx + p_{n+1}$$

In our case, our function accept as input the normalized color matrix of the 24 CIEXYZ values on the patch of the target image, and the normalized destination color space (in our case sRGB) measured values of the patches. It returns a structure containing the parameters needed to the fitting by relating the values of the patches of the current image (the observed data) ( $y$ ), with the measured reference values (the expected data) ( $x$ ).

## 5. Results & conclusions

For the evaluation of the performances of the implemented methodology, different functionalities were tested in the context of architectural scenarios.

A. *ColorCheker finding*: a standard dataset of RAW camera images (i.e. free of any color correction) having a known color target was used (Fig. 3). Three cameras (Nikon D200, Nikon D3100 and Nikon D5300) with wide-angle lenses were used in the acquisition procedure. The dataset consisted of 15 images representing different cases and problems. The X-Rite ColorChecker Classic chart is included in every acquisition. The presented method, [45] and X-Rite ColorChecker Passport Camera Calibration Software [40] are compared on a set of 15 images depicting the target, presenting different and typical problems. Results are shown in Table 1, demonstrating that our solution outperforms the other two detection algorithms.

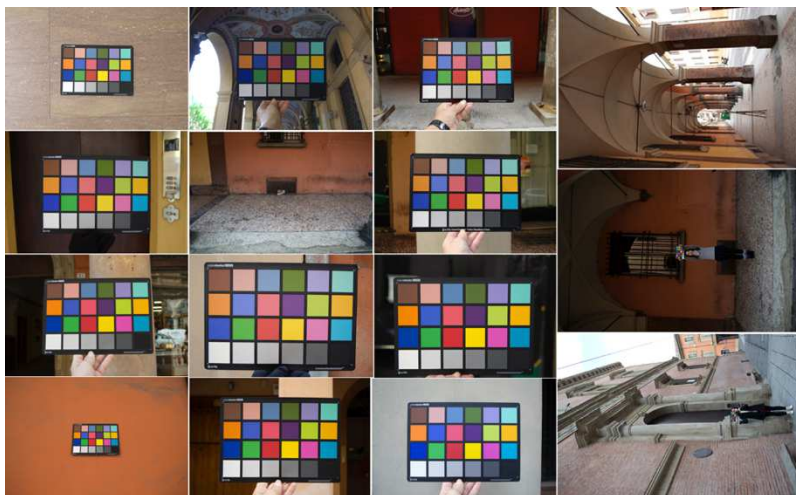

Fig. 3 – Dataset of 15 RAW images with ColorCheker evaluated.

	Our solution	Enhanced CCFind	X-Rite ColorChecker Passport Camera Calibration Software
Number of ColorCheker detected	15	13	7

Tab. 1 – Number of ColorCheker detected using different algorithm and using 15 images.

B. *Color fidelity*: The method for evaluating color accuracy includes: a physical reference chart acquired under the current illumination (corresponding to the illumination to be discard); a reference chart color space with the ideal data values for the chart; a way to relate or convert the device color space to the reference chart color space; and a way to measure and show errors in the device’s rendering of the reference

chart. The X-Rite ColorChecker Classic target is employed. Color accuracy was computed in terms of the mean camera chroma relative to the mean ideal chroma in the CIE color metric ( $\Delta E^*_{00}$ ) as defined in 2000 by the CIE on the CIEXYZ chromaticity diagram [49]. The formula is recommended by CIE mainly for color differences within the range 0-5 CIELAB units that is our case [50].

The  $\Delta E^*_{00}$  of the automated pipeline was also compared with the result of the previous manual workflow for a subset of targets used in *A*.

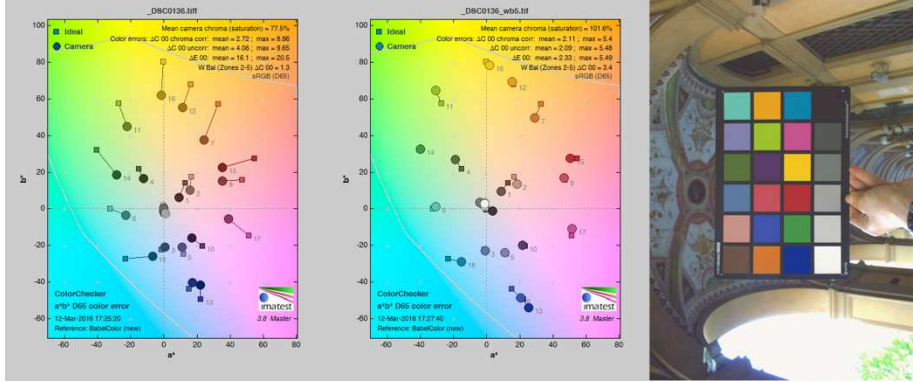

Fig. 4 – Color accuracy of manual (left) and automated (center) color balance of the image on the right.

File Name	$\Delta E^*_{00}$ manual sRGB	$\Delta E^*_{00}$ automated sRGB	Exposure error (f-stops) manual sRGB	Exposure error (f-stops) automated sRGB
_DSC0339.NEF	12	3,3	0,63	0,08
1_esterno__DSC2524.NEF	3,84	2,54	0,13	0,09
2_SOT-PORT_2_T4A4846.cr2	4,42	2,85	0,07	0,01
2_SOTPOR_2_DSC2801.NEF	4,36	3,05	0,18	0,11
ESTERNO_A-1_DSC2935.NEF	3,92	2,86	0,09	0,16
_DSC0134.NEF	4,47	2,11	0,19	0,01
_DSC0136.NEF	16,1	2,34	1,19	0,03
_DSC2118.NEF	7,98	2,4	0,41	0,01
_DSC2416.NEF	5,92	3,83	0,09	0,04
_DSC6062.NEF	5,71	2,42	0,04	0,02
<b>Mean error</b>	<b>6,544</b>	<b>2,77</b>	<b>0,302</b>	<b>0,056</b>
<b>Standard deviation</b>	<b>3,563</b>	<b>0,493</b>	<b>0,3431</b>	<b>0,049</b>

Tab. 2 –  $\Delta E^*_{00}$  evaluation.

As reference, we used the 8-bit sRGB by Denny Pascale [48] and the  $\Delta E^*_{00}$  calculation was made using the ColorChecker tool of Imatest Master software version 3.9 [41]. Exposure error in f-stops was also evaluated. Best results are obtained if it is less than 0.25 f-stops. Results are shown in Table 2 where a great improvement over the manual solution is evident.

Figure 4 reports the mean camera chroma relative to the mean ideal chroma in the CIE color metric ( $\Delta E^*_{00}$ ) and the color analysis for the above image. Results of manual color balance are on the left whereas automated workflow results are on the right.

C. *Photogrammetric pipeline*: the performances of the previously presented pre-processing are evaluated in the photogrammetric pipeline and reported using the statistical output of the bundle adjustment (re-projection error), the number of points in the dense point cloud and the pairwise matching efficiency. For the image processing, we combined a calibrated version SIFT as detector/descriptor [51], VisualSfM as bundle adjustment [52] and nframes SURE [53] for dense stereo matching. Two different image networks (Fig. 5 and Fig. 6) with different imaging configurations, textureless areas and repeated pattern/features of AH were employed. The two datasets represent an urban test framework and summarizes a typical historical urban scenario.

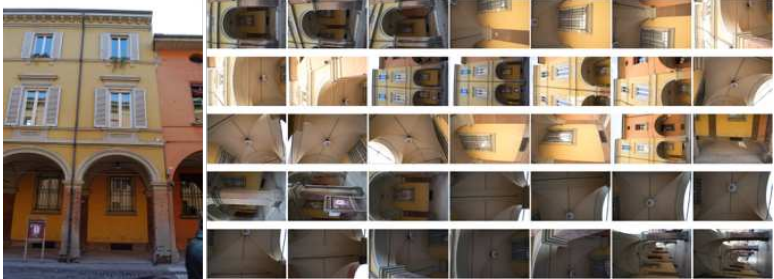

Fig. 5 - The porticoes dataset.



Fig. 6 - The Palazzo Albergati dataset.

	No Enhancement	Enhanced	Automatically enhanced
Oriented images	39	39	39
PBA quality	0.427	0.487	0.511
Points 3+ cameras	14001	13911	10758
Dense SURE	29173640	30394116	30644190
Point on image _DSC3201	8174	7835	6824
Inlier matches	605	413	444

Tab. 3 – Dataset Albergati – photogrammetric process results.

	No Enhancement	Enhanced	Automatically enhanced
Oriented images	17	21	21
PBA quality	0.981	0.537	0.562
Points 3+ cameras	777	3216	3115
Dense SURE	1107508	1.368.590	1.412.165
Point on image _DSC6305	4688	6288	5412
Inlier matches	148	159	162

Tab. 4 – Dataset Portico 35 – photogrammetric process results.

The datasets contain convergent images, some orthogonal camera rolls and a variety of situations emblematic of failure cases, i.e., 3D scenes (non-coplanar) with homogeneous regions, distinctive edge boundaries (e.g., buildings, windows, doors, and cornices), repeated patterns (recurrent architectural elements, bricks, etc.), textureless surfaces and illumination changes. Images of both datasets were acquired using a Nikon D3100 with a 18 mm nominal focal length. The first dataset (35 images) pertains two spans of a three floors building (6 x 11 m) characterized by arches, pillars/columns, cross vault and plastered wall. Camera moved along the porticoes, with some closer shots of the columns (Figure 5). The second dataset (39 images) depict a three floors historical palace (54 x 19 m) characterized by repeated brick walls, stone cornices and a flat facade. Camera move along the façade of the building, with some closer shots of the entrances (Figure 6). In Tables 3 and 4 the results show an excellent improvement with the applied automated image enhancement.

In this paper we presented a new automatic solution to ensure color fidelity in automatic photogrammetry and to increase the processing performances of the two central steps of the photogrammetric pipeline. We demonstrated the pre-processing technique developed performs well both in the recognition of the target, both in the room color calibration, both in the photogrammetric pipeline.

## References

- [1] F.I. Apollonio, et al., "A color digital survey of arcades in Bologna", *Colour and Colorimetry Multi-disciplinary Contributions*, Vol. IXB, 2013, pp. 58-68.
- [2] J. Heinly, et al., "Reconstructing the World in Six Days (As Captured by the Yahoo 100 Million Image Dataset)", *CVPR Proceedings*, 2015, pp. 3287-3295.
- [3] E. Reinhard, et al., "Color Imaging Fundamentals and Applications", A.K. Peters, 2008.
- [4] H.P.A. Lensch, et al., "Image-based reconstruction of spatial appearance and geometric detail", *ACM Transactions on Graphics*, Vol. 22, N. 2, 2003, pp. 234-257.
- [5] P. Allen, et al., "Seeing into the past: Creating a 3D modeling pipeline for archaeological visualization", *Proceedings of 3DPVT '04*, 2004, pp. 751-758.
- [6] M. Gaiani, et al., "An Advanced Pre-Processing Pipeline to Improve Automated Photogrammetric Reconstructions of Architectural Scenes", *Remote Sensing*, Vol. 8, N.3, 2016, pp. 27.
- [7] C. Stamatopoulos, et al., "Accuracy aspects of utilizing raw imagery in photogrammetric measurement", *ISPRS Archives*, Vol. XXXIX-B5, 2012, pp. 387-392.
- [8] [www.cybercom.net/~dcoffin/dcrawl/](http://www.cybercom.net/~dcoffin/dcrawl/).
- [9] S. Shafer, "Using color to separate reflection components", *Color Research and Application*, vol. 10, n. 4, 1985, pp. 210-218.
- [10] G. Klinker, et al., "A physical approach to color image understanding", *IJCV*, Vol. 4, N.1, 1990, pp. 7-38.
- [11] T. Gevers, A. Smeulders, "Color-based object recognition", *Pattern Recognition*, Vol. 32, N. 3, 1999, pp. 453-464.
- [12] M. Fairchild, "Color Appearance Models", 2nd Ed., John Wiley & Sons, 2005.
- [13] G. Fischer, M. Sajja, "Whitebalpr a new method for automatic white balance", *IS&T's European Conference on Color in Graphics, Imaging and Vision Proceedings*, 2008, pp. 202-207.
- [14] J. Golz, "The role of chromatic scene statistics in color constancy: Spatial integration", *Journal of Vision*, Vol. 8, N. 13, 2008, pp. 1-16.
- [15] P. Green, L.W. MacDonald, "Colour Engineering: Achieving Device Independent Colour", John Wiley & Sons, 2002.
- [16] S. Westland, et al., "Computational Colour Science using MATLAB", John Wiley & Sons, 2004.
- [17] A. Chakrabarti, et al., "An empirical camera model for internet color vision", *BMV Proceedings*, 2009, pp. 51.1-51.11.
- [18] K. Seon Joo, et al., "A new in-camera imaging model for color computer vision and its application", *IEEE Transaction on PAMI*, Vol. 34, 2012, pp. 2289-2302.



- [19] P. Debevec, J. Malik, "Recovering high dynamic range radiance maps from photographs", SIGGRAPH '97 proceedings 1997, pp. 369-378.
- [20] T. Mitsunaga, S.K. Nayar, "Radiometric self calibration", CVPR Proceedings, 1999, pp. 374-380.
- [21] S. Lin, et al., "Radiometric calibration from a single image", CVPR Proceedings, 2004, pp. 938-945.
- [22] B. Shi, "Self-calibrating photometric stereo", CVPR Proceedings, 2010, pp. 1118-1125.
- [23] G. Hong, et al., "A Study of Digital Camera Colorimetric Characterization Based on Polynomial Modeling", Color Research and Application, Vol. 26, N. 1, 2001, pp. 76-84.
- [24] ISO 17321-2006 Graphic Technology and Photography: Colour Characterisation of Digital Still Cameras (DSCs) Part 1, (ISO, Geneva), <http://www.iso.org>.
- [25] P. Green, M. Kriss, "Color Management: Understanding and Using ICC Profiles", John Wiley & Sons, 2010.
- [26] H. R. Kang, "Computational Color Technology", Society of Photo Optical, 2006.
- [27] D. Nyström, "Colorimetric and multispectral image acquisition using model-based and empirical device characterization", SCIA 2007 Proceedings, 2007, pp. 798-807.
- [28] P. Green, L.W. MacDonald, "Colour Engineering: Achieving Device Independent Colour", John Wiley & Sons, 2002.
- [29] C.S. McCamy, "A Color Rendition Chart. Journal of Applied Photographic Engineering", Vol. 11, N. 3, 1976, pp. 95-99.
- [30] B.A. Wandell, J.E. Farrell, "Water into Wine: Converting Scanner RGB to Tristimulus XYZ", Proceedings of SPIE 1909, 1993, pp. 92-101.
- [31] F.M. Abed, et al., "Geometry-Independent Target-Based Camera Colorimetric Characterization", Journal of Imaging Science and Technology, Vol. 57, N. 5, 2013, pp. 50503-1-50503-15.
- [32] S. Süsstrunk, et al., "Standard RGB color spaces", IS&T/SID CIC Proceedings, 1999, pp. 127-134.
- [33] M. Stokes, et al., "A Standard Default Color Space for the Internet - sRGB", 1996.
- [34] T. Tajbakhsh, R.-R. Grigat, "Semiautomatic color checker detection in distorted images", SPPRA '08 Proceedings, 2008, pp. 347-352.
- [35] A. Ernst, et al., "Check my chart: A robust color chart tracker for colorimetric camera calibration", MIRAGE '13 Proceedings, 2013, art. 5, pp. 8.
- [36] A. Kordecki, P. Henryk, "Automatic detection of color charts in images", Przegląd Elektrotechniczny, Vol. 90, N. 9, 2014, pp. 197-202.
- [37] S. Wang, et al., "A Fast and Robust Multi-color Object Detection Method with Application to Color Chart Detection", PRICAI 2014 Proceedings, 2014, pp. 345-356.
- [38] M. Liu, et al., "A New Quality Assessment and Improvement System for Print Media", EURASIP Journal on Advances in Signal Processing, Vol. 109, 2012, pp. 17.
- [39] S. Bianco, C. Cusano, "Color target localization under varying illumination conditions", Lecture Notes in Computer Science, Vol. 6626, 2011, pp. 245-255.
- [40] X-Rite, X-Rite ColorChecker Passport User Manual, <http://www.xrite.com/documents/manuals/en/>
- [41] Imatest Master, <http://www.imatest.com/products/imatest-master/>
- [42] BabelColor PatchTool, <http://www.babelcolor.com/>
- [43] R. Baumann, "MacDuff ColorChecker Finder", <http://github.com/ryanfb/macduff>
- [44] K. Hirakawa, "Color Checker Finder", <http://campus.udayton.edu/~ISSL/software>
- [45] L.E. Garcia Capel, et al., "Automatic Color Reference Target Detection", Color and Imaging Conference Proceeding, 2014, pp. 119-124.
- [46] R. Sumner, Processing RAW Images in MATLAB, <https://users.soe.ucsc.edu/~rcsumner/>, 2013.
- [47] <http://www.opengl.org>
- [48] D. Pascale, "RGB Coordinates of the Macbeth ColourChecker", The BabelColour Company, 2006.
- [49] G. Sharma, et al., "The CIEDE2000 Color-Difference Formula: Implementation Notes, Supplementary Test Data, and Mathematical Observations", Color Researc and Application, Vol. 30, N. 1, 2005, pp. 21-30.
- [50] M. Melgosa, et al., "Practical demonstration of the CIEDE2000 corrections to CIELAB using a small set of sample pairs", Color Research & Application, Vol. 38, N. 6, 2013, pp. 429-436.
- [51] D. Lowe, "Distinctive image features from scale-invariant keypoints", IJCV, Vol. 60, N. 2, 2004, pp. 91-110.
- [52] <http://ccwu.me/vsfm/>
- [53] K. Wenzel, et al., "SURE - The ifp Software for Dense Image Matching", Photogrammetric Week '13, Wichmann, 2013, pp. 59-70.



# Photometric and photorealistic representation of luminaires in 3D software

<sup>1</sup>Andrea Siniscalco, <sup>2</sup>Gianluca Guarini

<sup>1</sup>Dipartimento di Design, Politecnico di Milano, andrea.siniscalco@polimi.it

<sup>2</sup>Gianluca Guarini - Rendering per architettura, info@gianlucaguarini.it

## 1. Introduction

The continuous increase of the computational power (faster results) of today's computer contributed to the diffusion of 3D representation software used by designers to produce the so-called photo realistic renderings. The goal of these images, usually, is to show what should be the final look of the project.

Very often, unfortunately, these representations are the result of empirical graphic representation based (in the best cases) on the experience of the designer and his ability to achieve images that are similar to what he plan to realize. However, when these forecast images are produced without a precise methodology in the management of virtual materials or the importing and integration of technical data of lighting products, the resulting digital images, although their strong visual impact, do not match the final appearance of the project once put in place.

Having a beautiful image to present to the clients may help the designer to get the job, but in the end, if the real scene (with all of its luminaires, finishes and materials) is too different from the virtual image presented, there can be problems with the clients.

This paper is part of a more wide work on representation and is meant as a help for the designers, by using modelling and representation techniques that are quick, efficient and that suit better the typology of selected lighting fixture. Our aim is to describe some accurate and practical techniques of modeling and representation of the lighting fixtures in a virtual project, while maintaining both photo-realism and photometric accuracy.

These procedures can be used in the most common 3D software (for modelling and representation).

## 2. Modeling

Often the designer, in order to speed up the modeling process, makes use of 3D models available online from the manufacturer's website or portal/libraries dedicated to three-dimensional computer graphics.

Unfortunately, these models are not always suitable for the production of forecast images, for various reasons. Some time they are conversion of models that have been created for the CNC (Computer Numerical Control) of the objects, so with the purpose of the realization of a physical model; or maybe with a different setting of the coordinates system. This can result in the first case in a model with excessively many polygons and in the latter, a model that can have "inverted Normals" (that result in visible "holes" in the surfaces of the objects).

In these cases the better choice is to rebuild the model of the luminaire, defining from the beginning the desired level of detail and therefore the modelling technique that allows the designer to obtain a good result and in an efficient way, by thinking to the final rendering from the beginning.

The level of detail is fundamental in order to not wasting time, needed for modelling (user time) and for the rendering (computational time). The designer must be aware whether the luminaire will be represented in the foreground, the background or in an intermediate situation. In the latter case, the modelling techniques used, have to allow changes in the resolution of the 3D model, increasing the resolution (and thus the quality and the computational time required) of the geometry in relation to the importance of the model in the scene (using for instance the subdivision modelling).

The choice of the best modelling technique depends from the geometry of the luminaire that can be made of one single piece or by multiple components (in this case, the techniques can be more than one). If the model can be assimilated to basic geometries, it will be enough to use the CSG (Constructive Solid Geometry) modelling. The primitives available in the software (cubes, spheres, cylinders, cones, toroid, etc.) are edited with basic transformations such as move, rotate, scale or copy.

If the model turns out to be more complex, but still can be built with operations of addition, subtraction or intersection between two or more solids, it is possible to use the so-called Boolean operations. These are very fast in order to obtain complex geometries even if they can cause two order of problems: visual continuity between the polygons (strange shadows and colors) and topology (the organization of the polygonal structure) of the model. In the most common modelling software there are tools that allow to solve (or at least to improve) these problems.

The modelling based on 2D shapes is ideal in case of long (more or less flat) thick objects, so extrusion or taper operations can be effective.

Many lighting fixtures can be assimilated to 2D profiles that can be revolved around a specific axis. The “lathe” command, present in most of the modeling software, may allow the designer to obtain these geometries easily.

For parts such as cables, filaments, springs, it is possible to use modeling tools such as Sweep or Loft [1].

Sweep allows the creation of 3D geometries by making a profile (generated by the user or available on a library) “run” along a path (always generated by the user) keeping its perpendicular aligned to the tangent of the path

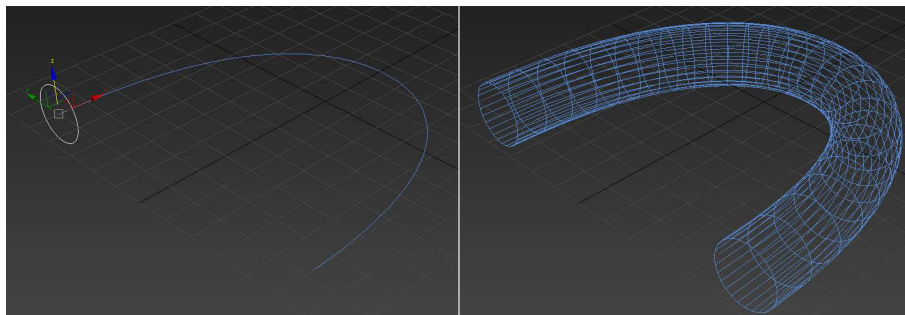

Fig. 1 – Example of the use of the Sweep tool. On the right, it is possible to see the circle that will act as profile running on the path (in this case a curve). On the left the resulting geometry.

The operation done by the Loft tool is similar to the one of the Sweep tool, but with more options. It is possible to scale, rotate or twist the profile, along the path,

modifying the resulting geometry. If no one of the previous tools can be used efficiently, the modelling technique that allow the designer to reproduce the most complex shapes is the Polygonal modelling [2].

Generally, starting from images (most likely technical drawings, the “blueprints”) used as planes of projection; it is possible to start from a primitive solid (or a single polygon) and rebuild the entire object (by moving and/or adding vertices and polygons). It is good practice to begin realizing a low-poly model (when possible) and then increasing the number of polygons at will, by using a “Subdivision tool”. This procedure split up the interested polygons in four parts and (if present) relax the adjacent polygons (also divided) creating a more smooth geometry. The process can be repeated more times intervening on a single parameter (number of iterations). However, it is necessary to pay attention to the number of iterations selected, because for each one, the number of polygon of the interested area quadruplicates, increasing exponentially the weight of the 3D model and the time needed to calculate the renders.

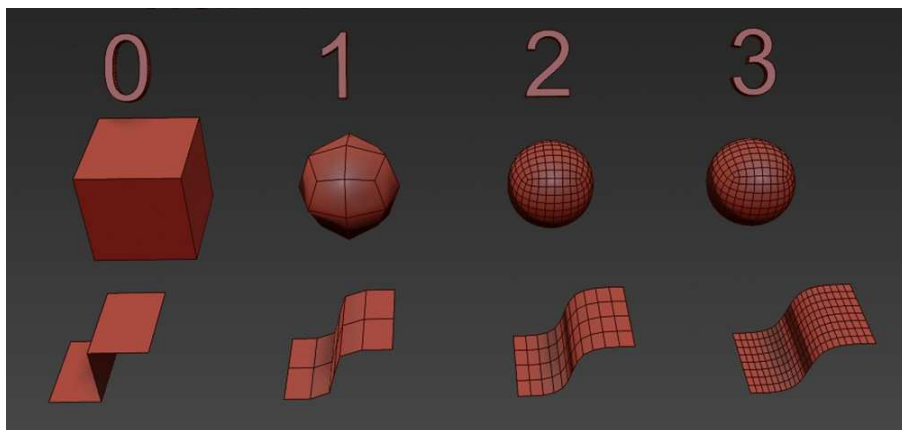

Fig. 2 – Example of increase in the number of polygons in relation to the number of iterations choices for the object.

In order to decide how many iteration are needed for a model, as previously mentioned, the designer should know the importance of the object in the scene; for foreground objects, the number of iterations will be much greater than for objects in the background.

### 3. Photometry

Once achieved the goal of a balanced (quality/weight) 3D model, it is necessary to transform the obtained geometry into a luminaire that can be used to render the final scene.

A desirable thing is to use the software as a verification tool (how my project will look like, if I choose one luminaire instead of another) and not just to produce attractive images. In order to do so, it is necessary that the software in use is equipped with calculation algorithms that approximate the real light distribution in space, in a plausible manner. This is possible only when indirect light is actually calculated by the interaction of the emitted light and the surfaces of the scene, and

not simulated with hypothetic parameters such as “ambient light” (used in some software to increase the amount of diffused light in the scene).

In the past (in software used to do lighting verification), these calculations were made by the algorithms of Radiosity (which allowed the simulation of light diffused evenly in all the directions and the soft shadows) and integrated by Ray tracing algorithms (used to calculate specular reflections and sharp, defined shadows). Nowadays, the programs specialized in light calculations have been updated with more recent algorithms such as Photon mapping (frequently available also on common modelling and representation software) or the rapidly diffusing Physically based render.

That said it must be clear to the designer that it is not possible to get reliable results by using the typical (found in every representation software) light sources of computer graphics (such as OpenGL Ambient, Point, Directional, Spot).

The real luminaires have (in most cases) a spatial distribution of intensity more complex than these defined by OpenGL lights. As an example, it is very easy to understand that the light distribution in space of a road luminaire is not similar to that of a table lamp or a spotlight (used for example in a retail premise). Each luminaire has a real light distribution, which is the result of interaction between the lamp (commonly called "bulb") and the optical system of the device, generally designed to meet specific project requirements.

### 3.1. Photometric files

The "shape of emission" of light in luminaires is generally measured by using an instrument called Goniophotometer that performs an angular investigation on the emission and saves the results in ASCII files containing (along with other parameters) a table that put in relation spatial angles with the light intensity emitted by the luminaire. These files are generally called Photometric files, or Photometric webs.

Obviously, these shapes are more complex than the OpenGL lights (that are not able to imitate these shapes).

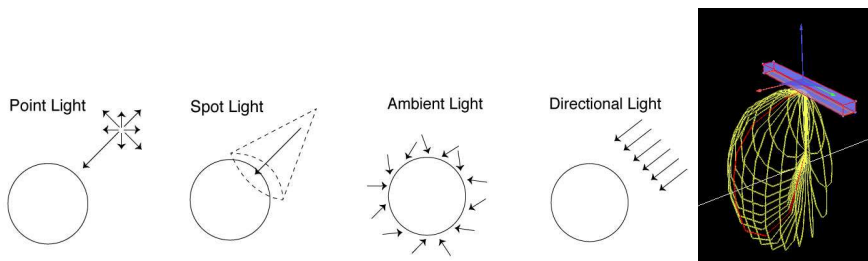

Fig. 3 – From left to right, different generic light sources commonly used in 3D softwares: Point, Spot, Ambient and Directional. The far right shows the photometric web of a real lighting fixture (Mellow Light IV by Zumtobel)

The photometric files are generated in different formats (mostly in relation to the nation in which they are acquired/crated) such as Eulumdat - \*.ldt (mostly Europe) [3], IESNA - \*.ies (America) [4], CIBSE TM14 - \*.cib (United Kingdom) [5], LTLI - \*.ltl (Denmark) [6].

In addition to these standard files are also several proprietary formats used by specific lighting design software, such as the format \*.uld (Dial - Dialux) [7], the

format \*.oxl (Oxytech - Litestar) [8] or the format \*.rolfz (Relux Informatik - Relux) [9], which are often integrated with a 3D model that is usually given by the luminaire manufacturer (and not always modelled properly).

Obviously these latter formats are read only by their programs (whose main purpose is not the photorealistic rendering, but rather the photometric verification) and cannot be opened (photometric data + 3D model) with the software commonly used for photorealistic renderings.

The choice given to the designer is to import (in compatible software) the most common photometric files (such as Eulumdat) or other open formats (IESNA, CIBSE, LTLI) which can simulate the actual light distribution of the equipment, but still, not their physical appearance.

In order to reproduce the appearance of a luminaire it is necessary to couple the geometric model to its corresponding photometric web (usually recovered from the manufacturer or obtained by a relief in a laboratory).

### **3.2. Model and Photometry coupling**

After modelling the geometry of the luminaire with the methods suggested in paragraph 2, it is necessary to place a light source whose emission properties will be those of the photometric web. The photometric files are related to a point in space that emits light with different intensities as vectors in space.

In the physical reality, these intensities are the result of the interaction between the light emitted by the source (discharge in gas, burner, LED, etc.) and the optical system of the luminaire (reflector, refractor, lenses, filters, etc.) and, for this reason, the measured photometric file already considers these interactions.

Consequently, it is important that the three-dimensional model of the luminaire, does not interact (for instance, by cutting off) with the emission of the photometric web. In many software, this is possible by editing the properties of the light source so that some objects (in our case, the part of the luminaire that emits light, in which the photometric web will probably be placed) do not interact with the light (specifically, it does not cast shadows).

In order to complete this task correctly, the designer need to place the light source (photometric web) in a correct way according the modelled geometry. Logic would suggest placing the photometric web in the same position where the light source is found in the real luminaire. In reality, the solution is not so simple.

Where to place the photometric web (that is always assimilated to a point) when the light source is widespread? What is the placement position when, inside of the luminaire, there are multiple lights sources (such in the case of LED lighting fixtures)?

If the purpose is the photometric accuracy and the program allows you to exclude parts of the geometry from the lighting calculation, the correct position is that of the “photometric center” of the luminaire.

The photometric center is defined as the point where the luminaire is aligned with the measuring instrument (the goniophotometer) during the relief in which the photometric file is generated. The correct position of this point is described by the standards for the light fittings measurement, which may vary from country to country (for instance America [4] and Europe [6]) and result into the generation of different photometric files.

It is possible to consider the photometric center as the locus from which the light is emitted, and therefore, it should be considered as the point of junction between the geometry of the 3D model and the photometric files.

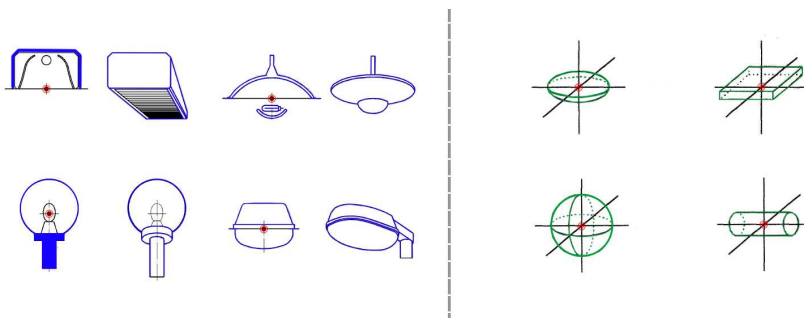

Fig. 4 – To the left (in blue) some guidelines for the identification of the photometric center (also called photometric zero), marked in red, as prescribed by the European standard UNI EN 13032-1. To the right (in green), some of the prescription provided by the American standard IESNA LM-63-02.

The operation of identification of the photometric center is easier for the categories described by the standard. Nevertheless, for some luminaires (mostly decorative) with very complex shapes, it is necessary to use some simplifications and adjustments (and this happens for the goniophotometric relief as well). For instance, a complex chandelier will hardly have a photometric file, but if the file exist, probably it will be not described in any standard. In this case, the designer should look at the shape of the photometric web, at the position of the light sources (by looking to a catalogue or the brochure of the product) and deduce the position of the photometric center that in most cases, correspond to the center of the geometry of the luminous part of the fixture.

#### 4. Color

A fundamental problem in the representation of the luminaires (and light in general) is constituted by the limits pf the representation devices. The computer-generated images are mostly produced to be displayed on video; it can also happen that these images are printed, maybe with high resolution but still, the means of typical representation, are unable to compete with the dynamic of the physical reality. This is true regarding both the luminance contrasts, and the spectral component of light. Having to use a representation device (usually a monitor), all of the colors must be converted to RGB triplets (Red, Green, Blue).

A mixture of three components does not compose light in physical reality; it is an electromagnetic radiation composed by different wavelengths of which, our visual system can perceive only the portion between 380 and 780 nanometers (so violet, indigo, blue, green, yellow, orange and red).

Given this, it is also necessary to specify that often, the light sources commonly used in luminaires, have nonlinear emission spectra (different form that of the sun, for example) but rather incomplete or in bands (peaks in certain colors). This is the reason why some light sources are less effective in render colors. Under these light sources, some colors appears to be dull and grayish.



The chromaticity of a computer generated light source, must necessarily be converted into an RGB triplet (to be represented common monitors, which are matrices of RGB LEDs), but also when the user have to decide the color of a light source within the modelling software, the most used method is still RGB.

Sometimes color presets are available in the interface (for example relating to different technologies or different color temperatures), but even if the chosen values recall the real physic, in practice, the light is colored only by changing the RGB values.

Nevertheless, there are some rendering programs [10] [11] [12] [13] [14] [15] [16] [17] [18] that implement algorithms able to mimic (more or less) the spectral behavior of light, displaying the color by simulating the spectral colors (with a given spectral step, for example simulating the properties with steps of 10nm).

There are many ways to implement these algorithms, but generally, although they allow higher accuracy in the calculation of color (simulating more correctly phenomena such as the spectral dispersion or the lower color-rendering index of some light sources), this cost globally in terms of greater complexity of use and extended computation times.

The same concepts are valid also for the materials applied (the so-called “shaders”) in the scene, which by reflection, refraction and transmission, can affect the spectrum of light by dispersion or by reflecting or transmitting only certain wavelength (and thus, changing the color of light).

If the will of the designer is to remain faithful to the physics of real world, it is necessary [19] to use a software that calculates light and its interaction with materials (shaders) with a full spectrum algorithm.

## **5. Case studies**

Three case studies of digital representation of real luminaires will be described below, but before starting, a little premise is necessary: the described techniques (modelling and rendering) are not the only ones that can be used. The focus is to achieve models that are clean, efficient and with a level of detail that can be increased or decreased at will.

The software used for this case studies is 3D Studio Max 2016 by Autodesk, but these techniques can be easily reproduced in any compatible modelling software.

### **5.1. *Evoluzione by Disano illuminazione***

Evoluzione is a very common fluorescent linear lamp produced by Disano Illuminazione. The simple, straightforward design is also reflected on the simplicity of the modelling process. The luminaire is obtainable with five geometric shapes: a parallelepiped for the external shell, an extruded profile for the aluminum reflectors, cylinders for the lamps, other parallelepipeds for the lamp-holders and the side abutment.

The external shell is obtained by a parallelepiped, where on the lower face is visible a hole (obtained by subtraction of another parallelepiped). The thickness of the shell is obtained by using a command that create (with a given thickness) a series of polygons parallel to the existing ones (usually this command is indeed called “Shell”).

The profile of the reflector is extruded for the length of the luminaire, and closed at the sides, by the abutments, created by two parallelepipeds. These two elements are placed inside of the external shell.

The fluorescent lamps are obtained with four cylinders (primitives) while a polygonal modification of a parallelepiped, allow the designer to create the lamp holders.

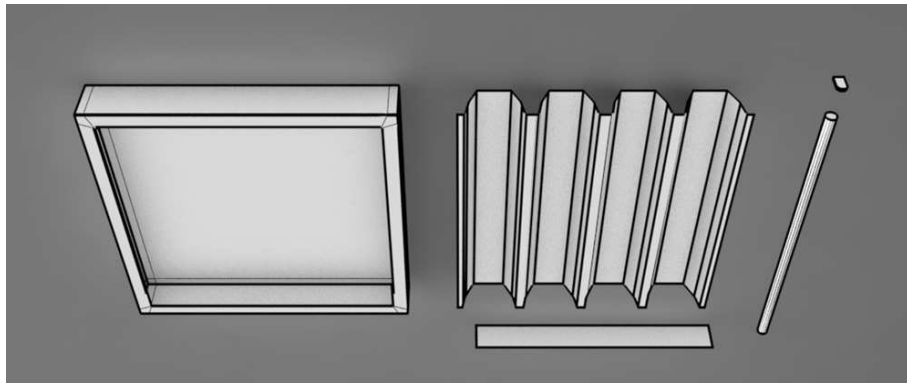

Fig. 5 – Basic geometric components for the 3D modelling of Evoluzione by Disano Illuminazione.

After the model is created, it is necessary to find the correct photometric file to couple with the model. As in most case, these files can be downloaded from the website of the manufacturer. To place the light source (photometric web) in the right position (photometric center) the designer should look at the standard. In this case, both the American [4] and European [6] standards states that the photometric center is in the center of the luminaire (intersection of median axes) at the height of the lower face of the external shell. It is important not to modify the values of intensity inherited by the photometric file, because these are the measured values of the luminaire.

The problem should be very visible right now: how it is possible to simulate the appearance of the four luminous tubes with just one photometric file (that, in this case, emits only downwards). Only with the photometric file, this is impossible. The tubes will appear dark, even if the luminaire is actually emitting. To solve this, the designer must use a little trick. First, it is necessary to assign the correct shaders to the geometry, paying attention to the energy balance of materials, because it is necessary to reproduce the real finishes (specular, diffused or combined reflections) and the right index of reflection (or transmission and refraction) of each part of the model. For Evoluzione, the external shell is a highly diffusive painted (white) metal with a small reflective component (around 65% diffusive and 5% reflective). The other parts (except the tubes) are made of brushed aluminum (70% specular with glossiness lowered to 50%).

To obtain the fluorescent tubes, it is necessary to use a self-illuminating material (many representation software possess this kind of shader) in order to simulate the light coming out from the tubes. Two important elements must be considered while using such material: first, the self-illumination effect must be visible in the reflections of the other components and second, the light emitted by the self-

illuminated material must be ignored in the global calculation of the scene. This because if the light of the self-illuminated material is computed, it will invalid the luminous emission of the photometric file, producing unrealistic results.

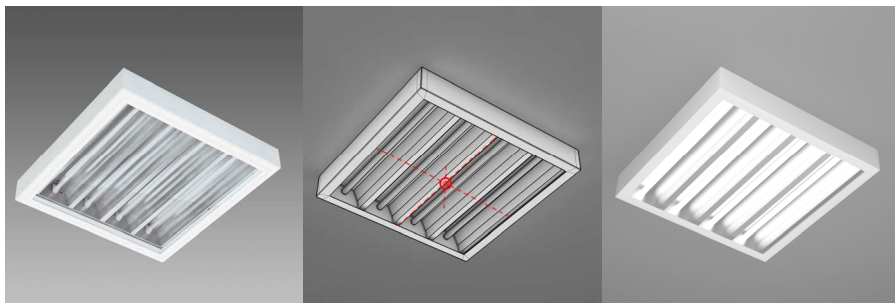

Fig. 6 – From left to right: picture of the luminaire, geometric model of the luminaire (red sign indicates the photometric center) and production render of the luminaire.

### **5.2. Caboche suspension by Foscarini**

The geometry of this luminaire is highly populated with elements that obviously, will affect the weight of the final scene. In order to create the “skeleton” of the object, a primitive can be used (in this case, a half-torus with a low number of polygons) and replicate in a roto-symmetric way. The refracting elements are created starting from spheres, modified in the junction part toward polygonal modelling. The body that hosts the LED light source (which is not visible because the glass is opaline) with polygonal modelling starting from a half-sphere and the same, for the element that holds the luminaire on the ceiling; in this element some of the Polygons were removed in order to create the cuts for the wiring.

Cables and suspension wires are created starting from lines and curves. It is possible to create the element and then use a command to create a thickness (at a given diameter) or, it is possible to use the “Loft” tool.

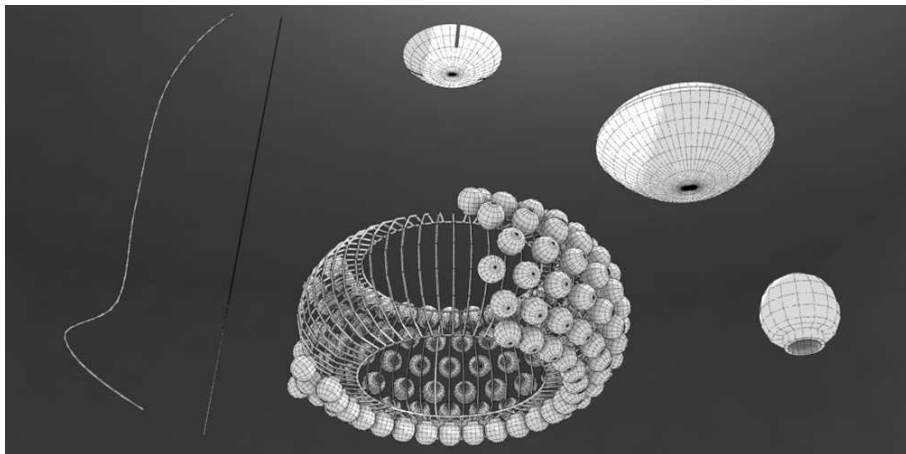

Fig. 7 – Basic geometric components for the 3D modelling of Caboche by Foscarini.

The materials for the Caboche line are an opaline blown glass for the luminous body, polymethylmethacrylate for the spheres and polycarbonate for the arches, stainless steel for the suspension cables and transparent electrical cable for the power supply.

The crucial element in this luminaire is the crown of spheres that refract the light coming from the luminous element placed in the center. In order to achieve this effect, the spheres must be considered as solid geometry so it is possible to take advantage of the index of refraction (around 1.49 for the PMMA) to achieve the refraction effect. The other materials should not be difficult.

The position of the photometric center, following the indications (figure 5, profile 10) of the European standard [6], is in the center of the suspended element (and not inside of the luminous body as logic may suggest). It is also important to pay attention to the orientation of the photometric web. In this case, for example, the emission of the luminaire is both direct and indirect. The designer must identify the right verse of the emission by looking at the polar diagrams of the luminaire on the catalogue or the manufacturer's website. In this case, the higher intensities are oriented downwards, so the photometric web must be oriented accordingly.

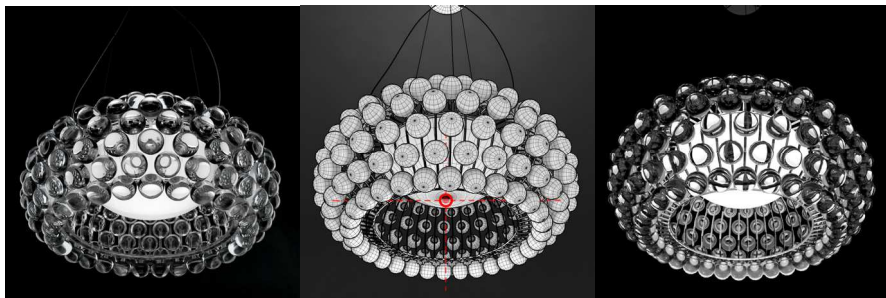

Fig. 8 – From left to right: picture of the luminaire, geometric model of the luminaire (red sign indicates the photometric center) and production render of the luminaire.

### 5.3. Aoy by Flos

The shape of this luminaire can be easily obtained from the cylinder primitive, paying attention to increase the amount of segments enough (if the luminaire is in the foreground an approximation to 32 segments may be a good choice).

The arch at the base is obtained by subtracting a shape (another cylinder) and refining the geometry with polygonal modelling, removing the unnecessary polygons and vertices created by the Boolean subtraction.

The opaline goblet inside of the cylinder can be obtained by extruding the upper part of the cylinder downward and then detaching it from the rest of the body.

The upper reflector is created by revolving a curve along the vertical axis (with a “Lathe” tool). Lathe can be used also to create the two elements that form the light bulb. The first three elements need to have depth, so the “Shell” command must be used. Also in this model, it is possible to use subdivisions in order to adapt the resolution of the polygonal mesh in relation to the position of the luminaire in the scene.

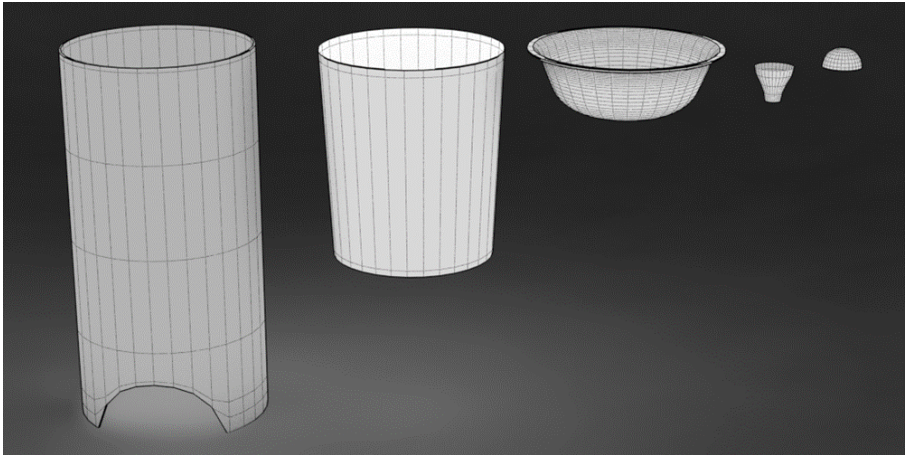

Fig. 9 – Basic geometric components for the 3D modelling of Aoy by Flos.

The external body is made of clear glass and the internal diffuser and reflector are made of white, opaline glass. The light source is a bulb, with the upper half with a chrome finish that serves as anti-glare system.

The position of the photometric web in this case is not in the center of the luminaire, but in correspondence of the light source. The European standard [6] states that for luminaires with transparent sides or without side members, the photometric center correspond to the lamp photometric center.

Another element to keep in consideration is that this fixture (in dark environments) creates a slight caustic effect at the base of the luminaire.

In order to achieve so, the software used must be able to calculate caustic, and the effect has to be set up properly.

The opaline diffuser and reflector may need a little improvement with a self-illuminated material and, to achieve the caustic effect (and for physical correctness), they also must be removed from the calculation of shadows together with the bulb.

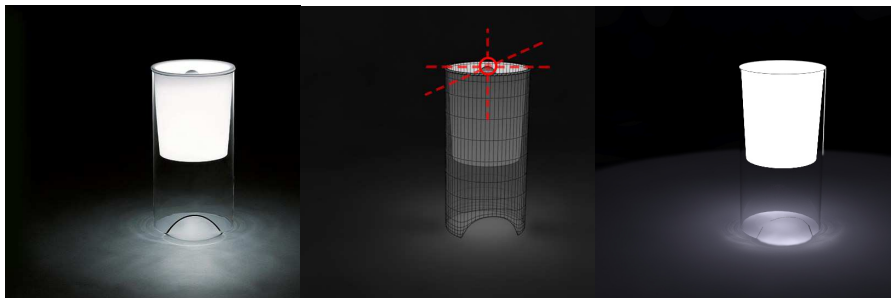

Fig. 10 – From left to right: picture of the luminaire, geometric model of the luminaire (red sign indicates the photometric center) and production render of the luminaire.

## 6. Conclusions

The techniques described can change in relation to the software used and the shape of the luminaires (that can span from very simple to incredibly complicated passing through an infinite number of variations). All the objects can be created in many ways, but the techniques described are efficient and allow the designer no to worry about the weight of the model (that can directly affect the time of calculation).

Synthesizing very quickly, the important steps are:

- The study of the luminaire (geometry, photometry and materials, directly on the catalogues or manufacturer website)
- What to represent (hidden components should not be modelled)
- Select the technique (the most efficient way to model all the visible parts)
- Scalability (trying to provide a method to change the resolution in relation to the importance of the luminaire in the scene)
- Correct position of the light sources (coupling the photometric data with the geometry, placing the photometric web in the correct spot)
- Creating the visual aspect of the object (materials and properties to set in order to respect the physics of the real world, and overcoming the limitations of the system geometry/photometry).

## Bibliography

- [1] F. D'agnano, "3ds Max per l'architettura" Apogeo, Marzo 2008.
- [2] T. Daniele, "Poly-Modeling with 3ds Max: Thinking Outside of the Box" Focal Press, October 2008.
- [3] A. Stockmar, "<http://www.helios32.com/Eulumdat.htm>" Light Consult Inc. Berlin 1990.
- [4] Standard ANSI/IESNA LM-63-02 (R2008).
- [5] "CIBSE TM14 Standard File Format for Transfer of Luminaire Photometric Data", Chartered Institution of Building Services Engineers, 1988.
- [6] Standard UNI EN 13032-1.
- [7] Dialux: <https://www.dial.de/>
- [8] Litestar: <http://www.oxytech.it/>
- [9] Relux: <http://www.relux.biz/>
- [10] Arion: <http://www.randomcontrol.com/arion>
- [11] Fluid Ray: <http://www.fluidray.com/features/technical-specs/#tab-id-3>
- [12] Indigo renderer: <http://www.indigorenderer.com/features/technical>
- [13] Lux render: [http://www.luxrender.net/wiki/Features#Physically\\_based.2C\\_spectral\\_rendering](http://www.luxrender.net/wiki/Features#Physically_based.2C_spectral_rendering)
- [14] Mental ray: <http://docs.autodesk.com/MENTALRAY/2014/CHS/mental-ray-help/files/manual/spectral.html>
- [15] Mitsuba renderer: <http://www.mitsuba-renderer.org/>
- [16] Octane: <https://home.otoy.com/render/octane-render/features/>
- [17] Thea renderer: <https://www.thearender.com/site/index.php/features.html>
- [18] Ocean: <http://www.eclat-digital.com/spectral-rendering/>
- [19] M. Radziszewski, K. Boryczko, W. Alda, "An improved technique for full spectral rendering" Journal of WSCG - vol. 17, no. 1-3, Václav Skala - UNION Agency, 2009.

### **3. COLOUR AND LIGHTING**





# Warm white, neutral white, cold white: the design of new lighting fixtures for different working scenarios

Daria Casciani, Fulvio Musante, Maurizio Rossi

Dept. of Design, Politecnico di Milano, [daria.casciani@polimi.it](mailto:daria.casciani@polimi.it), [fulvio.musante@polimi.it](mailto:fulvio.musante@polimi.it), [maurizio.rossi@polimi.it](mailto:maurizio.rossi@polimi.it)

## 1. Introduction

Nowadays office lighting is fundamental for vision and for increasing wellness and working performances by considering the physiological and psycho-perceptual, social, behavioural and postural factors in relation to the working luminous environment.

### **1.1 Trends: the future of office working activities and environments**

The design of the future workspaces should take into account the overall management of work and the social aspects that are established in the workplace. The work done in offices is becoming more nomadic, less tied to the needs of a fixed workstation and predetermined, but potentially executable everywhere in the office space or out of it, globally, in every part of the world.

The work is an inherently social process which requires that people quickly pass from a focused job (individual tasks of processing, concentrating or relaxing moments), to team working (creative collaborations), to sharing activities (meeting with communications and presentations)<sup>1</sup>. Each of these activities can be configured in different physical postures and requires different luminous atmospheres that are consistent with the context, the purpose and performed work activities. The use of new technological tools is inducing new ways to move and work in the office environment, in the micro space of the human body postures and in the macro environment of the entire workspace<sup>2,3</sup>: the multimodal use of different technological devices for reading and working (pc displays, keyboards, tablet etc.) is determining different visual field and tasks<sup>4</sup>. Work environments nowadays require flexibility in the arrangement of furnishings and the increased possibility of reconfiguring the space, in addition to the need of managing the personal space in a situation where the job done individually is reduced in favour to shared and team activities<sup>5</sup>. Recent studies of office future trends reveal the importance of creating healthy spaces in which workers can be “energized” or “relaxed”, passing from concentration to relaxation, where they can suspend their activities for periods of “daydreaming” to refresh mentally and to be more productive in the long term<sup>6</sup>.

### **1.2 More than functional lighting**

Traditionally, office lighting fixtures are focused on limiting glare, providing energy efficiency and durability: in the majority of offices they are equipped with fluorescent tubes with correlated colour temperature (CCT) 4000K and very limited controllability. On the other hand, more than only achieving the required illuminance on the work/task area, lighting should be adjustable in relation to individual physiology, age and health. Nowadays, lighting research and design are focused on two macro-themes that converge and intersect: the new Solid State Lighting technology (SSL) and Human Centric lighting (HCL)<sup>7</sup> with its strategic importance both in driving the correct application of the new SSL technologies and also in improving the quality of life (wellbeing, mood, health) of individuals. Office lighting can influence people wellbeing and behaviours through circadian rhythm

activation/suppression by synchronizing the timing of the biological clock. Previous studies show that specific circadian lighting receipts (quantity, spectrum, distribution at eye level, timing, duration) are important for helping people in concentrating and improving cognitive performances at work, improving alertness and vitality, providing better sleep quality<sup>8</sup> and enhancing the general mood<sup>9</sup>.

The luminous environment can enhance people mental and cognitive regeneration<sup>10</sup>,<sup>11</sup> and contribute to the wellbeing and productivity of individuals. Numerous studies have explored the issue of the regenerative potential in the workplace<sup>12,13</sup> but a limited number of studies has focused on the importance of lighting in reducing mental fatigue and increasing cognitive performances<sup>14,15,16</sup>. Despite of this, for enhancing the wellbeing of people, an environment should visually reconnect to nature both with natural lighting<sup>17</sup> (access to daylight through the window)<sup>18,19</sup> and with artificial lighting, creating non-rhythmic sensory stimulation through the dynamics and variation of spectrum and distribution. This performance reconnects the individual to natural performances by creating a more complex and intriguing visual scenario through biomorphic shapes and patterns<sup>20</sup>. Several experiments and studies demonstrate that office workers prefer lighting which is distributed in a direct-indirect way, with some of the light being reflected off the ceiling and surrounding surfaces<sup>21,22,23</sup>.

The quality of life of individuals can be enhanced also if they can control their lighting: research demonstrates that, when people work in environments that can be changed according to their personal preferences, they evaluate the lighting as of higher quality and the office as more attractive. In such an environment, they tend to develop a more positive mood, to work in a more focused way and this can influence their general wellbeing.<sup>24</sup>

### **1.3 Controllable lighting at work**

In order to ensure that individuals are able to experience their favourite lighting levels and luminous atmospheres to accompany different working activities and tasks, lighting should be flexible by providing a certain degree of control in terms of illuminance<sup>25</sup>, white tuning or spectral tuning<sup>26,27,28,29</sup> but also lighting distribution<sup>30</sup>. The individual control of lighting is positive not only for personal customization of the lighting atmosphere and for influencing positively the mood of people contributing to personal and environmental satisfaction<sup>31</sup> but also in terms of energy efficiency by reducing the energy use in comparison to the typical fixed light level provided in offices<sup>32,33</sup>.

By allowing a wider level of controllability and new lighting functionalities, the new SSL based lighting fixtures need more precise digital controls, more calibrated lighting performances and more complex, but user-oriented interfaces which ensure the complete freedom with usability and recognition of functions, experience/pleasure of use and satisfaction in the control<sup>34</sup>.

In particular, advanced systems are required in order to guarantee the understanding of multiple functionalities and control possibilities: the user interface and the user interaction are a wide and new field of investigation in the lighting design field. In particular, with tangible user interfaces (TUI), such as innovative remote controls, and with surface user interfaces (SUI), such as displays of tablet and smartphones, the user can control the lighting in a more precise way by adjusting single lighting

parameters or in a more abstract way by setting up preset-based lighting scene (where all the parameters are changed simultaneously) based on lighting atmosphere or work activities. In addition, the literature<sup>35</sup> shows that it is preferred to save personal lighting scenes for later recall.

## **2 Research scope**

This article would analyse in detail the importance of implementing LED lighting engines that provide white tuning by describing and comparing the characteristics of two experimental prototypes realized at the Laboratorio Luce – Politecnico di Milano: COELO and ASTERISM. Conceived as innovative lighting fixtures, they include the possibility to vary the intensity from a maximum to a minimum value and the Cold - Warm White tuning by running on a daily schedule, with an internal timer, or modifiable at a personal level through direct interaction. These luminaries could be applied for activate or suppress circadian stimulation, for behavioural control, for matching the colours with natural lighting (daylight during day, warmer dimmer light in evening), for cooling or warming the room to counteract exterior temperatures and for tuning lighting atmosphere according to users' preferences. COELO and ASTERISM were developed for research scopes in order to test the photometric, optical, quantitative and qualitative performance of the tuning of white shades close to the black body curve in an efficient way. In addition to this, the prototypes were used to implement several hypothesis of user interaction with the lighting system.

## **3 Method**

The lighting engines, COELO and ASTERISM were designed and prototyped for technological assessment to test different lighting scenarios that have been defined through the previously presented extensive literature review. The different possibilities of dynamic lighting concerns:

- dimming from 0 (OFF) to 100 (ON);
- white tuning;
- control of direct and indirect lighting distribution independently;
- variation of lighting scenarios.

By measuring, evaluating and analysing these lighting prototypes, this paper aims at highlighting the following issues: colour mixing in relation to the optical systems, range of colour tuning in relation to efficiency and Colour Rendering Index (CRI), lighting functions and user interface.

## **4. COELO**

The prototype COELO is a semi-direct suspended lighting fixture for a single working location in a small office. It consists of four parts:

- Box for LED driver, Arduino and XBee Shield mounted on the ceiling;
- Reflective structure for direct and indirect light distribution;
- Lighting engine with Blue LEDs and Remote Phosphor (3000K-5000K);
- Management and control system.

The overall dimensions of the lighting system are 630 x 346.5 x 152 mm (height).

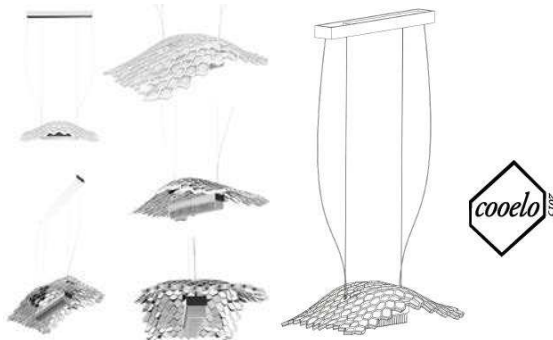

Figure 1 - COELO lighting prototype

#### 4.1 Lighting performances

The lighting engine is characterized by royal blue LEDs (48 LED Luxeon Rebel LXML-PR01-0425), four separated mixing chambers coated with a highly diffusive material for a better white lighting uniformity and remote phosphors of two different CCT (Intematix Corporation CL-830-L225-PC and CL-750-L225-PC). The lighting engine addresses its emission to a faceted reflector which is inspired by nature in the geometric repetition of the hexagonal pattern and reflect light while generating glitter effects and the scattered image of the emitting lighting source. In addition, the central part of this structure is characterized by transparent facets in order to have lighting on the ceiling of the room.

COELO meets the parameters of maintained average illuminance, uniformity and comfort in terms of glare in accordance with the UNI EN 12464-01. Its lighting performance is direct downwards lighting (60%) and indirect upwards lighting (40%), in order to avoid the "cave effect". The device, installed at 1.2m from the workplane, provides an average level of illuminance of 280 lux with a uniformity of  $E_{min}/E_{ave}=0.6$  on the visual task (1.6m x 0.8m) and an average level of 140 lux on the surrounding area (2.6m x 1.8m), with a uniformity value of  $E_{min}/E_{ave}=0.45$ . The UGR index value is below 19 calculated for 5 different observers located (sitting or standing) in the simulated room. The lighting performance can be controlled by dimming the intensity from 0 to 100 and tuning the CCT from 3000K to 4900K. The diminished value of the cold CCT is derived by the known phenomena of interaction between the plastic material and the incident light beam: the plastic used in the prototype structure (obtained through rapid prototyping techniques such as stereolithography) has modified the CCT, by warming the tone of white of 100K.

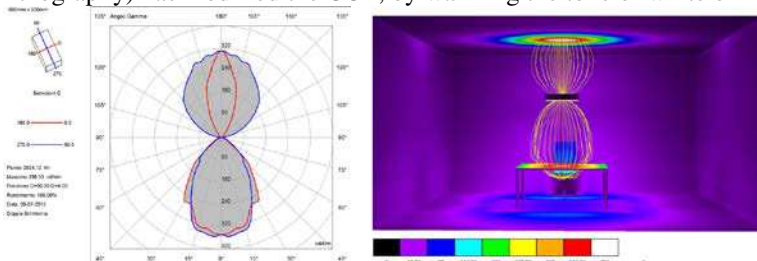

Figure 2 - COELO lighting performance: photometric distribution and illuminance false colours representation



Figure 3 - COOELO lighting performance: direct –indirect lighting prototype with different CCT

## 5. ASTERISM

ASTERISM was conceived as a modular lighting fixture for the multifunctional desk, able to evolve in different shapes and configurations, by taking into account different working scenarios, from individual to collective working modalities. Unlike a monolithic lighting system, it is composed by several functional modules which ensure the maximum flexibility of installation in terms of spatial composition and lighting distribution/variation in relation to working activities.

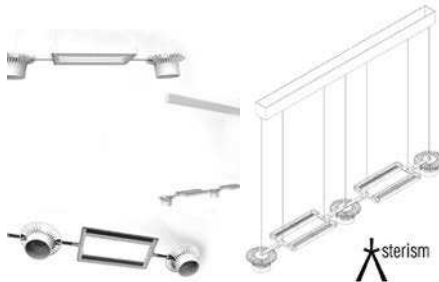

Figure 4 - Asterism lighting prototype

Asterism consists of a supporting structure with connected lighting modules to create a constellation of luminous elements. The main elements are:

- box for LED driver, Arduino board and XBee Shield mounted on the ceiling;
- three modules for direct illumination (down-light);
- four modules for indirect lighting (light-up);
- management and control system.

### 5.1 Lighting performances

The device consists of a direct emission, realized by means of three spots equipped with 4 LED CREE MC-E Dynamic White and a LENS LEDIL C10702-Rocket-4-W with a measured beam aperture equal to  $2 \times 22^\circ$ . The indirect emission is ensured by 8 modules with 18 Mid-Power 3030 LED SEOUL STW8C2SA in two CCT and they are equipped with asymmetric optics (LEDIL C12446\_SOPHIE).

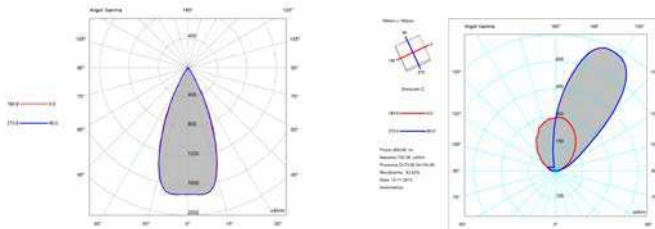

Figure 5 - On the left: photometric distribution of the direct lighting module; on the right: photometric distribution of the indirect lighting module

All the modules for direct and indirect lighting can be controlled autonomously in term of dimmability from 0 to 100 and white tunability between 3000K to 6000K.



Figure 6 - ASTERISM lighting performance: direct –indirect lighting prototype with different CCT and single modules controllability

Asterism can be controlled by varying the following lighting scenarios (Figure 7):

- **Scenario 1–Workshop** supports the multifunctional work in teams during meeting and networking situations or processing group activities. Each direct lighting module is individually controllable (lighting levels and CCT). The indirect lighting guarantees visual clarity with a neutral CCT, increasing the perceived space for a welcoming public dimension.
- **Scenario 2–Focus** ensures the creation of an environment suitable for individual work, where the increased focus on the visual task implies higher level of illuminance and neutral/cold CCT (central direct module) in the area where the user is working. The surroundings are evenly lit from indirect lighting (neutral/cold CCT) ensuring a balance of luminance with the background.
- **Scenario 3–Haven** configures a private working environment, with lighting direct on the work surface of the desk, ensuring moderate levels of illumination in the visual task. Indirect lighting is off or dimmed at low levels in order to reduce the perceived space of the room, creating a confined environment for a subjective solitary concentration.
- **Scenario 4–Relax** defines a relaxing work environment ideal for a break from the pace of a daily working routine and for the attention restoration after a prolonged mental and visual fatigue. Lighting would be mainly indirect (3000K) exploiting the ceiling and walls while direct lighting will be turned off or adjusted to a minimum.

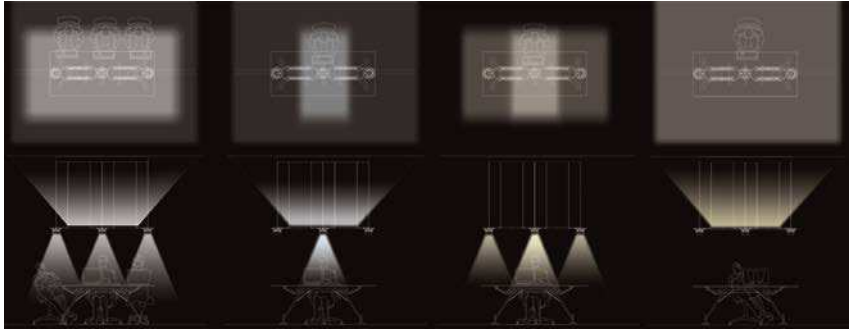

Figure 7 - From left to right: Scenario 1-Workshop; Scenario 2-Focus; Scenario 3 –Haven; Scenario 4-Relax

## 6. Measurements

In relation to the evaluation of the luminous performance of the devices, a series of laboratory measurements were carried out to verify the chromatic performances of the lighting prototypes.

The results reported in this paper are limited to the prototype Asterism, considering only direct emissions on the reference plane, for which a deviation between the measured and predicted values would be more critical. For this reason, the direct lighting module of the prototype Asterism was measured in accordance to the following protocols:

- Measures of the spectral power distribution for the assessment of chromaticity, CCT and CRI, considering different settings of the luminaire in terms of emitted luminous flux and tone of light. The measurements were conducted by measuring the emission in the axis of the device, at a distance of 0.75m.
- Measures for evaluating colour uniformity of the incident light on a target screen, changing the CCT and leaving constant the value of the emitted flux (in first approximation, it is assumed that the regulation of emitted luminous flux does not modify the activation proportions of the two channels). The screen was placed at 0.75m from the luminaire.

## 7. Results

Figure 8 shows the extent of the deviation of the CCT emitted from the direct beam with respect to the nominal value: in an ideal luminaire, the curve should be a straight line tilted at  $45^\circ$  with respect to the abscissa axis independently of the adjustment for the emitted flux. As shown in the Figure 8, we can conclude that the adjustment is very good for large values of the emitted luminous flux (100% and 75%), while it tends to worsen for cold CCT, when the emitted luminous flux is reduced to 10% compared to the maximum value.

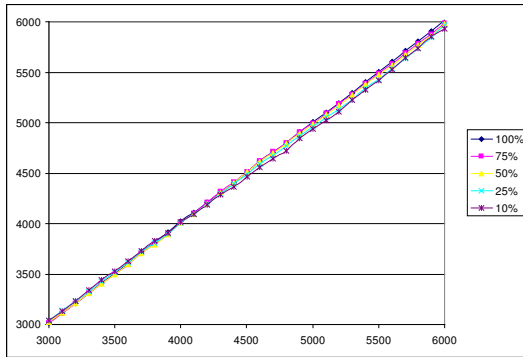

Figure 8 - Trend of measured colour temperature (ordinate axis) in accordance with the corresponding rated value (abscissa axis)

For a proper evaluation of the influence of this deviation from a perceptual point of view, the following procedure was used:

- Determination of relevant parameters (semi-axes and inclination) for a 3-step MacAdam ellipses corresponding to the chromaticity measured by setting the device to the maximum output flux and by adjusting the CCT between 3000K and 6000K in steps of 500K
- Fixed a CCT inside the specified range, the values of chromaticity were measured changing the percentage of emitted flux (75%, 50%, 25%, 10%)
- It was then established that, all chromaticity values obtained by dimming, fall within the corresponding ellipse.

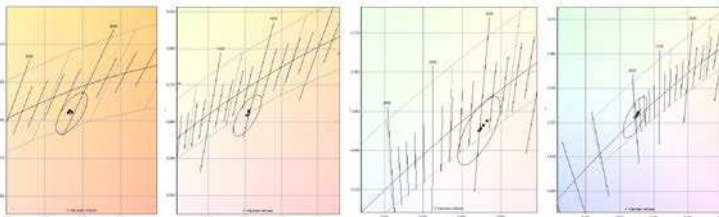

Figure 9 - Evaluation of the constancy for the chromaticity of emitted light changing the percentage of emitted flux. Measurements from left to right of 3000K-4000K-5000K-6000K

Figure 9 shows the results obtained by applying the described method: with the variation in flux, chromaticity remains almost constant with respect to the value obtained at maximum output, regardless of the value of the selected colour temperature.

### 7.1 Colour mixing in relation to the optical systems

The colour's uniformity of the emitted beam was evaluated by observing the image formed on a screen perpendicular to the axis of the luminaire placed at a distance of 0.75m: the results are generally good for all the CCTs (Figure 10). The result essentially depends on the used lens and the aperture of the light beam which is not excessively wide; indeed very narrow opening would make critical mixing between the emissions of dies pairs that constitute the MC-E LED Dynamic White.



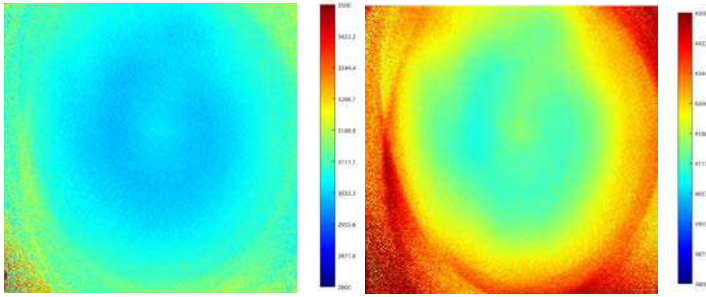

Figure 10 - Distribution map of CCT measured with 2D Colour Analyzer CA-2000 by Konica Minolta: on the left, Asterism direct lighting emission at 3000K; On the right 4000K

## 7.2 Range of colour tuning in relation to emitted luminous flux, efficiency and CRI

The percentage change of the lighting levels as function of the CCT is contained in approximately 2%, irrespective of the value of emitted flux (the chart in Figure 11 shows the results for 5 different settings of the emitted flux). Best results would be possible considering a more fine tuning of the management system settings, but it was not considered necessary since the differences are not visually perceptible.

The CRI  $R_a$ , defined according to the CIE publication 13.3 of 1995, varies in a range between 80 and 75, as function of the considered CCT: the index assumes the highest values for lower CCT values and decreases when the CCT increases.

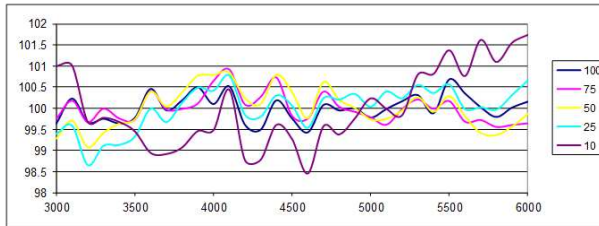

Figure 11 - Percentual variation of illuminance changing the CCT for different levels of dimming

The performance obtained is shown in Figure 12 (on the left). On the right the Figure 12 shows the index trend  $R_9$  according to the CCT: the decreasing trend of the graph with increasing CCT is mainly due to the growing proportion of cold light with increasing CCT. The two trends shown in the graphs are essentially due to the colour rendering characteristics of the used LEDs and not very dependent on the power supply system and the technique of adopted current regulation.

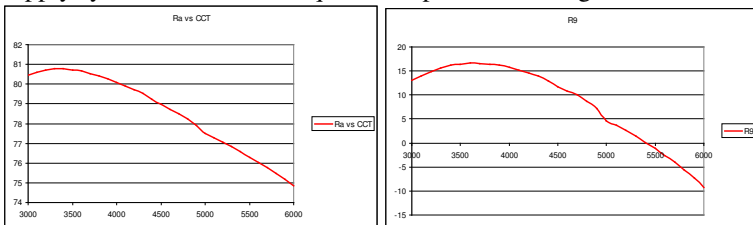

Figure 12 - On the left: CIE color rendering index  $R_a$  as a function of CCT; On the right: Results of special colour rendering index  $R_9$  as function of CCT

### 7.3 Lighting functions and user interface

Controls were a critical element in managing white-tuning of the prototypes and giving an intuitive user interface. Both the control platforms of the two lighting systems were enabled to tune smoothly through the CCTs without changing the total light output over the colour range. In addition to this, they allowed the control of the luminous output by maintaining stable the CCT and without causing flicker. Despite of the fact that both systems were equipped with two different controls (sliders), one for power and intensity level and the other for CCT, they show different levels of complexity in providing information and controlling different functionalities. In fact, the more complex are the lighting performance achievable, the more complex the user interface becomes.

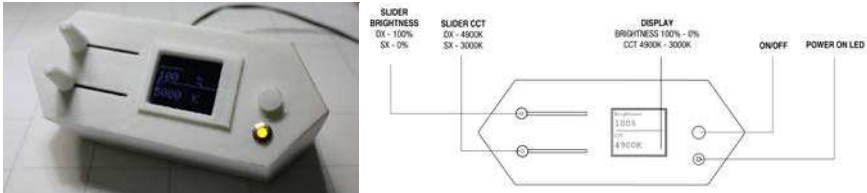

Figure 13 – COELO interface and control system

The COELO control platform (Figure 13) has a display to give direct visual feedback about the specific CCT and intensity level (in percentage). The ASTERISM control platform is more complex since each lighting module can be separately controlled with the possibility to play or record lighting scenes. The interface is provided with a visual diagram of switches representing the lighting modules of the prototype: each button allows to control each module differently in manual mode, adjusting both CCT and lighting levels.

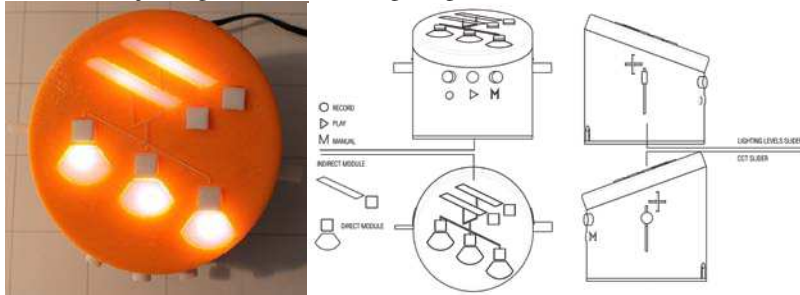

Figure 14 - ASTERISM interface and control system

In addition to this there are other controls that allow to switch from manual mode to record mode (it allows to record the lighting scenes) and play mode (it allows to play lighting scenes previously recorded).

## 8. Conclusion

The white tuning of the two prototypes was achieved in two ways:

- COELO: Phosphor conversion in which two different remote phosphors were placed above blue LED to convert the coloured light into white light;
- ASTERISM: phosphor-converted LEDs with two different CCTs.

The described measured lighting prototype (Asterism) was equipped with 2 LEDs white primaries and it is evident that the white tuning between 3000K and 6000K is performing sufficiently in terms of smoothness between different CCT with constant emitted flux. On the other hand, the CRI  $R_a$  diminishes with higher CCT and this is primarily dependent on the LEDs quality. These performances were achieved just by compiling a lookup table and by using a current controller based on PWM with 16 bits.

With a more complex lighting engine, equipped with more than 3 LEDs primaries (e.g. RGBW – RGBA – RGBAW), it would have been possible to enhance specific parts of the spectrum in order to achieve better CRI and specific colour rendering properties such as enhancing the Gamut area. In this more complex systems, it could be more difficult to create a stable CCT at different lighting intensities with a stable CRI. If the chromaticity of two different lighting fixtures is perfectly the same, the SPD (Spectral power Distribution) of these two may not be: this can make objects look different (because of different colour rendering capability). With RGBW fixtures, the same luminaire can be set up to render objects' colours in a variety of ways, from oversaturating to desaturating them, meanwhile the CCT doesn't change. In those situations a retroactive system is required for controlling and adjusting the lighting output through a temperature sensor for measuring the  $T_j$  of each LED primary or a shielded colour sensor for measuring the direct lighting emission.

## 9. Acknowledgements

The work described here was funded financially by ENEA and MSE and with in-kind support of the companies (LEDIL, ELITALIA) that have provided components for building parts of the customized prototypes.

## Bibliography

- 
- <sup>1</sup> O'Neill M. and Wymer T. (2010) Implementing Integrated Work to Create a Dynamic Workplace. Knoll
  - <sup>2</sup> Knoll Workplace Research (2013) Evolving Design of Faculty Offices. Space Efficient Planning Solutions for the Private Office,
  - <sup>3</sup> O'Neill, M. (2009). Future Work and Workplace. Knoll research white paper
  - <sup>4</sup> Global Posture Study – Steelcase by Steelcase WorkSpace. Futures researchers and the Steelcase Design Studio
  - <sup>5</sup> O'Neill, M. (2012) Adaptable by Design Shaping the Work Experience, Workplace Research Knoll, Inc.
  - <sup>6</sup> The Future Workplace – Key trends that will affect employee wellbeing and how to prepare for them today (2014) Unum
  - <sup>7</sup> Walerczyk S. (2012) Human Centric Lighting Architectural SSI ([www.architecturassl.com](http://www.architecturassl.com)) pp. 20 - 26
  - <sup>8</sup> MS Rea, MG Figueiro, and JD Bullough (2002) Circadian photobiology: an emerging framework for lighting practice and research, *Lighting Research and Technology*. September 2002; vol. 34, 3: pp. 177-187
  - <sup>9</sup> Stephenson K.M. Schroder C. M. Bertschy G. Bourgin P. (2012) Complex interaction of circadian and non-circadian effects of light on mood: Shedding new light on an old story *Sleep Medicine Reviews* 16 (2012) pp. 445 - 454
  - <sup>10</sup> Kaplan, S. (2001). Meditation, restoration, and the management of mental fatigue. *Environment & Behavior*, pp. 480-506.
  - <sup>11</sup> Berto, R. (2005). Exposure to restorative environments helps restore attentional capacity. *Journal of Environmental Psychology*, pp. 249-259.
  - <sup>12</sup> Finnegan, M. C. & Solomon, L. Z. (1981). Work attitudes in windowed vs. windowless environments. *The Journal of Social Psychology*, 115, pp. 291-292.

- 
- <sup>13</sup> Farley, K. M. J., & Veitch, J. A. (2001). A room with a view: A review of the effects of windows on work and wellbeing (IRC-RR-136). Ottawa, ON: National Research Council Canada, Institute for Research in Construction. Retrieved April 16, 2007, from <http://irc.nrc-cnrc.gc.ca/fulltext/tr136/>.
- <sup>14</sup> Kim, S.Y. & J.J. Kim (2007). Effect of fluctuating illuminance on visual sensation in a small office. *Indoor and Built Environment* 16 (4): pp. 331–343.
- <sup>15</sup> Figueiro, M.G., J.A. Brons, B. Plitnick, B. Donlan, R.P. Leslie, & M.S. Rea (2011). Measuring circadian light and its impact on adolescents. *Lighting Research and Technology*. 43 (2): pp. 201-215.
- <sup>16</sup> Beckett, M. & L.C. Roden (2009). Mechanisms by which circadian rhythm disruption may lead to cancer. *South African Journal of Science* 105, November/December 2009.
- <sup>17</sup> Kaplan, R., & Kaplan, S. (1989). *The experience of nature: A psychological perspective*. New York: Cambridge University Press.
- <sup>18</sup> Ulrich, R. S. (1984). View through a window may influence recovery from surgery. *Science*, pp. 224, 420-421
- <sup>19</sup> A Borisuit, F Linhart, J-L Scartezzini and M Munch, (2015) Effects of realistic office daylighting and electric lighting conditions on visual comfort, alertness and mood, *Lighting Research and Technology* 2015; Vol. 47: pp. 192–209
- <sup>20</sup> Browning, W.D., Ryan, C.O., Clancy, J.O. (2014). *14 Patterns of Biophilic Design*. New York: Terrapin Bright Green llc.
- <sup>21</sup> Zumtobel Research - Lighting quality perceived in offices Phase 1 | Data Analysis Europe. Fraunhofer IAO, Stuttgart | DE Zumtobel Lighting GmbH, Dornbirn | AT March 2014 Zumtobel Research ISBN 978-3-902940-50-6
- <sup>22</sup> Boyce PR et al. (2006). Lighting quality and office work: Two field simulation experiments. *Lighting Research and Technology*, 38(3),pp. 191-223
- <sup>23</sup> Veitch JA, Newsham GR (2000). Preferred luminous conditions in open plan offices: Research and practice recommendations. *Lighting Research and Technology*. 32, pp. 199-212.
- <sup>24</sup> Veitch JA, Stokkermans MGM, Newsham GR. (2013) Linking lighting appraisals to work behaviors. *Environment and Behavior*. 2013;45(2): pp. 198-214.
- <sup>25</sup> Boyce PR, Veitch JA, Newsham GR, Jones CC, Heerwagen JH, Myer M, Hunter CM. (2006). Occupant use of switching and dimming controls in offices. *Lighting Research and Technology*. 38(4): pp. 358-378.
- <sup>26</sup> Veitch JA, Dikel EE, Burns GJ, Mancini S. Individual control over light source spectrum: Effects on perception and cognition. Proceedings of the 27th Session of the Commission Internationale de l’Eclairage, Sun City, South Africa Vienna, Austria: CIE; 2011, July. CIE 197:2011, Vol. 1, Part 1, pp. 213-8.
- <sup>27</sup> Bieske K, Schierz C. (2010). Dynamic lighting—perception of luminous colour variation. In: Proceedings of CIE 2010 “Lighting Quality and Energy Efficiency.” Vienna (Austria): CIE. pp. 290-297.
- <sup>28</sup> Logadóttir Á, Fotios SA, Christoffersen J, Hansen SS, Corell DD, Dam-Hansen C. (2013) Investigating the use of an adjustment task to set preferred colour of ambient illumination. *Color Res Appl*. 38(1): pp. 46-57.
- <sup>29</sup> Žukauskas A, Vaicekauskas R, Vitta P, Tuzikas A, Petrulis A, Shur MS. (2012) Colour rendition engine. *Opt Express*. 20(5): pp. 5356-5367.
- <sup>30</sup> Van Boerdonk K., Mason J., Dzmitry A. (2011) User Interface for Task Lighting in Open Office Proceedings of the workshop on User Interaction Techniques for Future Lighting Systems pp. 23-27
- <sup>31</sup> Veitch JA, Dikel EE, Burns GJ, Mancini S.(2011) Individual control over light source spectrum: Effects on perception and cognition. Proceedings of the 27th Session of the Commission Internationale de l’Eclairage, Sun City, South Africa Vienna, Austria: CIE; 2011, July. CIE 197:2011, Vol. 1, Part 1, pp. 213-8.
- <sup>32</sup> Galasiu AD, Newsham GR, Svagau C, Sander DM. (2007). Energy saving lighting control systems for open-plan offices: a field study. *Leukos*. 4(1): pp. 7-29.
- <sup>33</sup> Maniccia D, Rutledge B, Rea MS, Morrow W. (1999) Occupant use of manual lighting controls in private offices. *Journal of the Illuminating Engineering Society*. 28(2): pp. 42-53.
- <sup>34</sup> Dugar M. A. (2013) Lighting Control System and End Users – Establishing an Interactive relationship in *Journal of Light & Visual Environment* N. 2 & 3, 2013 pp. 70-77
- <sup>35</sup> Van Boerdonk K., Mason J., Dzmitry A. (2011) User Interface for Task Lighting in Open Office Proceedings of the workshop on User Interaction Techniques for Future Lighting Systems pp. 23-27

# Daylight-simulator evaluation by “Special metamerism index: change in illuminant” (Computer program)

<sup>1</sup>Gabriele Simone, <sup>2</sup>Claudio Oleari

<sup>1</sup>Dip. di Tecnologie dell'Informazione, Università degli Studi di Milano, gabriele.simone@di.unimi.it

<sup>2</sup>Dip. Fisica e Scienze della Terra, Università di Parma, claudio.oleari@fis.unipr.it

## 1. Introduction

Daylight is the most important illuminant and source in colorimetry. Particular attention is given to the D65. The D65 exists as natural light in the day and as an illuminant, but a source emitting a light equal to that of the day does not exist. Simulated daylight can be achieved through many different methods: wide band fluorescent lamps, e.g., F7 and FL 3.15, filtered tungsten halogen lamp and other technologies. Certainly in the near future other daylight simulators will be produced. All of these simulators can produce sources with very good correlated color temperature (CCT) and chromaticity of the simulated daylight, but the reproduction of an equal spectral power distribution (SPD) is almost impossible.

These sources have a very high color rendering index (CRI), which is not adequate for judging color-rendering accuracy. A quantitative assessment of the suitability of a practical daylight simulator is made by computing the special metamerism index for a change in illuminant [1, 2, 3].

Since daylight has a content of UV radiation with consequent fluorescence, the daylight simulation regards fluorescent or non-fluorescent specimens. The CIE method considers pairs of virtual specimens, specified by their reflecting and fluorescing properties, which are metameric matches for the CIE 1964 observer under the reference CIE daylight illuminant. Two different indices are used, one to evaluate the visible region of the spectrum and the other one to evaluate the ultraviolet region. This method quantifies the mismatch when the pairs of virtual specimens are illuminated by the simulator under testing. The computation and the necessary numerical data are given by CIE[1, 2]. Then a grade, A, B, C, D, E, is given by CIE from the metamerism indices.

This work concerns the construction of a program for this calculation. From the CIE reports, this calculation is complex in terms of the algorithm definition. This complexity is described and analyzed.

The CIE method is described in details in Section 2 and an ad-hoc computer program is presented in Section 3.

## 2. CIE method for daylight simulation

As aforementioned, daylight has a content of UV radiation with consequent fluorescence, and thus the daylight simulation regards fluorescent or non-fluorescent specimens. As a consequence, two different indices are required, one to evaluate the visible region of the spectrum and the other to evaluate the ultraviolet region. The CIE method:

- i. considers pairs of virtual specimens, specified by their reflecting and fluorescing properties, which are metameric matches under the reference CIE daylight illuminant and for the CIE 1964 observer.
- ii. quantifies the mismatch when the pairs of virtual specimens are illuminated by the simulator under test.

The CIE method is only based on the computation and the necessary numerical data are given by CIE [2, 3].

The requirements and the steps for the computation are the followings (warning: in this work the wavelength is shown at times with  $\lambda$  and other times with  $\mu$  to avoid confusion in the event that there are operations dependent on wavelength present in the same equations to be considered separately):

The observer is the CIE 1964.

The spectral power distribution of the daylight simulator under test is known  $S(\lambda)$  (Fig. 1).

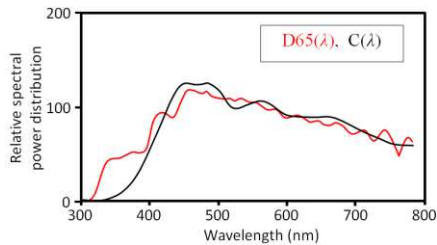

Fig. 1 – Comparison between the C illuminant and the D65, as example of test (daylight simulator) and reference illuminants, respectively.

The daylight simulator must have the chromaticity coordinates on the  $(u'_{10}, v'_{10})$  diagram within a circle having a radius of 0.015 centered in the chromaticity coordinates of the standard daylight illuminant (Fig. 2).

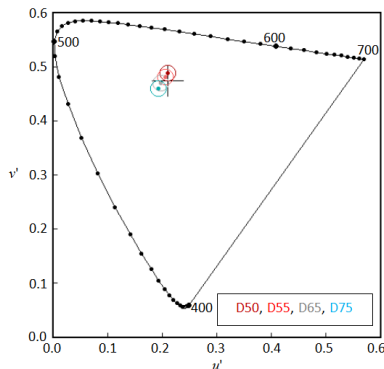

Fig. 2 - Allowable range of chromaticity coordinates of daylight simulators on the  $(u'_{10}, v'_{10})$  chromaticity diagram.

**Evaluation of spectral power distributions in the visible region**

CIE considers five pairs of virtual non fluorescent specimens constituted by 5 standard and 5 corresponding metameric samples. The standards are the same for all the daylight illuminants (D50, D55, D65, D75) and the metameric samples are proper of any illuminant.

The spectral reflectance factors  $R(\lambda)$  of the non-fluorescent specimens (standard and metamer) are directly known from the CIE tables [2,3] and are plotted (Fig. 3).

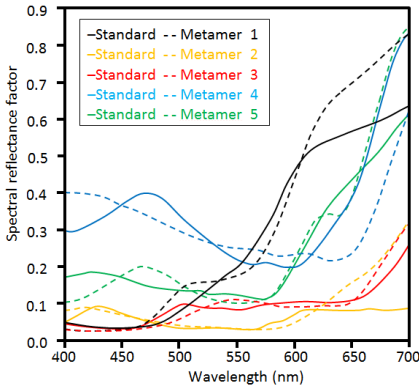

Fig. 3 - Spectral reflectances  $R(\lambda)$  of five metameric pairs used in the evaluation of D65 simulators in the visible range.

**Evaluation of spectral power distributions in the ultraviolet region**

The fluorescent color sample is illuminated by a source  $S$  with spectral power distribution  $S(\lambda)$  normalized as follows:

$$S_n(\lambda) = 100 \frac{S(\lambda)}{\sum_{\mu=400}^{700} S(\mu) \bar{y}_{10}(\mu) \Delta\mu} \quad (1)$$

A part of the incident radiation is reflected with a radiance factor  $\beta_R(\lambda)$  and a part is absorbed. The absorbed part, specified by the Luminescent (Fluorescent) radiance factor  $Q(\mu)$ , is re-emitted by fluorescence with Relative spectral distribution of radiant fluorescent emission  $F(\lambda)$ . It follows that a sample irradiated by the source  $S_n(\lambda)$  emits by fluorescence the radiance:

$$\beta_L(\lambda) = N \frac{F(\lambda)}{S_n(\lambda)} \quad (2)$$

where:

$$N = \sum_{\mu=300}^{460} S_n(\mu) Q(\mu) \Delta\mu \quad (3)$$

is the effective excitation and  $F(\lambda)$  is a relative quantity normalized to 1 as follows:

$$\sum_{\lambda=300}^{700} F(\lambda) = 1 \quad (4)$$

The total radiance factor related to the source  $S_n(\lambda)$  is:

$$\beta_T(\lambda) = \beta_R(\lambda) + \beta_L(\lambda). \quad (5)$$

Quantity  $S(\lambda)$  regards the light source, and  $\beta_R(\mu)$  (Fig. 4),  $Q(\mu)$  (Fig. 5) and  $F(\lambda)$  (Fig. 6) are related only to the color sample.

The definitions given by CIE Illumination vocabulary, compared with those given by CIE 51.2-1999, are given below.

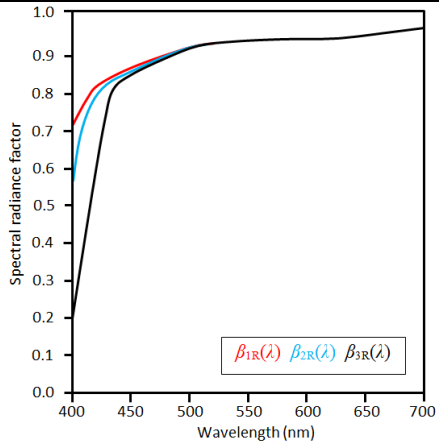

Fig. 4 - Spectral radiance factors  $\beta_R(\lambda)$  of the three CIE color samples defined in the visible range.

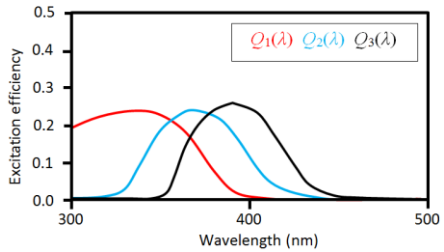

Fig. 5 - Fluorescent radiance factor  $Q(\lambda)\Delta\lambda$  of the three CIE color samples defined in the range 300-460 nm.

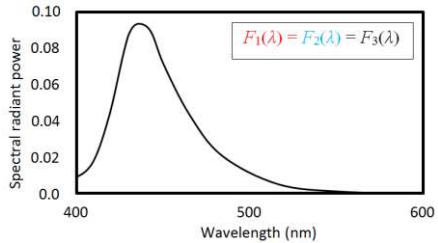

Fig. 6 - Relative spectral distribution of radiant fluorescent emission  $F(\lambda)$  of the three CIE color samples, which is the same for the three samples.

CIE considers three virtual fluorescent samples which are metameric with three non-fluorescent samples illuminated by one of the standard daylight illuminants (D50, D55, D65, D75). The functions  $Q(\lambda)\Delta\lambda$ ,  $\beta_R(\lambda)$  and  $F(\lambda)$  related to the CIE



fluorescent samples are directly known from the CIE tables [2, 3]. The reflected spectral radiance factors  $\beta_R(\mu)$  of the CIE specimens are plotted in Fig. 4. The quantities  $Q(\mu)\Delta\lambda$  and  $F(\lambda)$  related to the fluorescence are plotted in Figs. 5 and 6, respectively.

The total spectral radiance factors of the three fluorescent specimens are computed as follows:

- (1) the spectral power distribution  $S(\lambda)$  is normalized according to Equation (1);
- (2) a factor  $N$  taking into account the fluorescent emission is computed according to Equation (3);
- (3) the total spectral radiance factor  $\beta_T(\lambda)$  for the fluorescent sample lit by the simulator, according to Equations (2) and (5), is (Fig. 7):

$$\beta_T(\lambda) = \beta_R(\lambda) + N \frac{F(\lambda)}{S_n(\lambda)} \quad (6)$$

with the spectral distribution of the fluorescent component  $F(\lambda)$  normalized to 1 according to Equation (4).

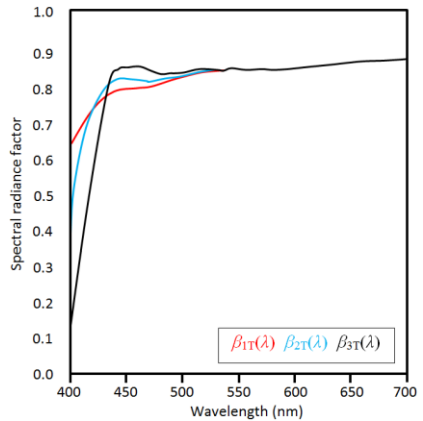

Fig. 7 - Total spectral radiance factor  $\beta_T(\lambda)$  for the fluorescent sample lit by the simulator defined in the visible range. The illuminant C is used as trial for simulating the D65.

The computation of  $(X_{10}, Y_{10}, Z_{10})$  for each specimen lit by the simulator  $S(\lambda)$  is made by Equation (7) with summations with 5 nm steps in the wavelength range 400-700 nm.

The computation of  $(X_{10}, Y_{10}, Z_{10})$  for each fluorescent specimen lit by the simulator  $S(\lambda)$  is made by equation (7) with summations with 5 nm steps in the wavelength range 400-700 nm (The total spectral radiance factor  $\beta_T(\lambda)$  substitutes the spectral reflectance factor  $R(\lambda)$  in Equation (7)). The spectral radiance factor of the non-fluorescent samples in three metameric pairs (metameric for D50, D55, D65 and D75) for the ultraviolet range evaluation is given by CIE in a separate table.

$$\begin{cases} X_{10} = K \sum_{\lambda=400, \Delta\lambda=5}^{700} S(\lambda)R(\lambda)\bar{x}_{10}(\lambda)\Delta\lambda \\ Y_{10} = K \sum_{\lambda=400, \Delta\lambda=5}^{700} S(\lambda)R(\lambda)\bar{y}_{10}(\lambda)\Delta\lambda \\ Z_{10} = K \sum_{\lambda=400, \Delta\lambda=5}^{700} S(\lambda)R(\lambda)\bar{z}_{10}(\lambda)\Delta\lambda \end{cases} \quad \text{with } K = 100 \left/ \sum_{\lambda=400, \Delta\lambda=5}^{700} S(\lambda)\bar{y}_{10}(\lambda)\Delta\lambda \right. \quad (7)$$

Then the color specification is made in the CIELAB or CIELUV systems, according to the color-difference formula considered.

The color difference between the five standards and the corresponding metameric samples is computed by one of the following color difference formulae:

The color difference between the three non-fluorescent samples and the corresponding three fluorescent ones is computed by one of the following color difference formulae:

$$\Delta E_{ab,10}^* = \sqrt{(\Delta L_{10}^*)^2 + (\Delta a_{10}^*)^2 + (\Delta b_{10}^*)^2}, \quad \Delta E_{uv,10}^* = \sqrt{(\Delta L_{10}^*)^2 + (\Delta u_{10}^*)^2 + (\Delta v_{10}^*)^2} \quad (9)$$

The metamerism index in the absence of fluorescence is obtained by an average  $M_v$  of the differences of five color pairs:

$$M_v = \frac{1}{5} \sum_{i=1}^5 \Delta E_i \quad (10)$$

where  $\Delta E_i$  may be  $\Delta E_{ab,10}^*$  or  $\Delta E_{uv,10}^*$ .

The metamerism index in the presence of fluorescence is obtained by an average  $M_u$  of the color differences of three color pairs:

$$M_u = \frac{1}{3} \sum_{i=1}^3 \Delta E_i \quad (11)$$

where  $\Delta E_i$  may be  $\Delta E_{ab,10}^*$  or  $\Delta E_{uv,10}^*$ .

Finally, a grade, A, B, C, D, E, is obtained from the metamerism indices as defined in the following table.

Grade	$M_v$ or $M_u$ based on $\Delta E_{ab}^*$	$M_v$ or $M_u$ based on $\Delta E_{uv}^*$
A	< 0.25	< 0.32
B	0.25 to 0.50	0.32 to 0.65
C	0.50 to 1.00	0.65 to 1.30
D	1.00 to 2.00	1.30 to 2.60
E	> 2.00	> 2.60

For clarity, the definitions of the quantities considered given by CIE Illumination vocabulary are recalled, compared with those given by CIE 51.2-1999:

<i>Definitions from CIE 51.2-1999</i> [4]	<i>Definitions from ILV CIE S 017/E:2011</i> [2]
	<b>Luminescence</b> emission of optical radiation caused by any non-thermal process
	<b>Fluorescence</b> the emission of optical radiation (light) when a substance is exposed to any type of electromagnetic radiation, where the emitted radiation generally appears within 10 ns after the excitation. NOTE: This effect is due to an “allowed” transition generally from an excited singlet state to a ground singlet state.
<b>Radiance factor</b> (at a representative element on the surface of a non-self-radiating medium, in a given direction, under specified conditions of irradiation). Ratio of the radiance of the medium to that of a perfect reflecting or transmitting diffuser identically irradiated. Symbol : $\beta$ NOTE: In the case of fluorescent media the radiance factor is the sum of two portions, the reflected radiance factor $\beta_R$ and the fluorescent radiance factor $\beta_L$ . $\beta_T = \beta_R + \beta_L$ This may be called the <b>total radiance factor</b> .	<b>Radiance factor</b> (at a surface element of a non-self-radiating medium, in a given direction, under specified conditions of irradiation) [ $\beta$ ]: ratio of the radiance of the surface element in the given direction to that of the perfect reflecting or transmitting diffuser identically irradiated and viewed. Unit: 1 NOTE: For photoluminescent media, the radiance factor contains 2 components, the reflected radiance factor, $\beta_R$ , and the luminescent radiance factor, $\beta_L$ . The sum of the reflected and luminescent radiance factors is the total radiance factor, $\beta_T$ : $\beta_T = \beta_R + \beta_L$
<b>Reflection radiance factor</b> (at a representative element of the surface of a medium, in a given direction, under specified conditions of irradiation):	<b>Reflected radiance factor</b> (at a surface of a non-self-radiating medium in a given direction, under specified conditions of illumination) [ $\beta_R$ ].

<p>Ratio of the radiance due to reflection of the medium to that of a perfect reflecting or transmitting diffuser identically irradiated.</p> <p>Symbol: <math>\beta_R</math>.</p>	<p>See NOTE to “radiance factor”</p>
<p><b>Fluorescent radiance factor</b> (at a representative element of the surface of a medium, in a given direction, under specified conditions of irradiation):</p> <p>Ratio of the radiance due to fluorescence of the medium to the radiance of a perfect reflecting diffuser identically irradiated.</p> <p>Symbol: <math>\beta_L</math></p>	<p>(mutatis mutandis)</p> <p><b>Luminescent radiance factor</b> (at a surface of a photoluminescent medium in a given direction, under specified conditions of illumination) [<math>\beta_L</math>].</p> <p>See NOTE to “radiance factor”</p>
<p><b>Fluorescence radiant efficiency:</b></p> <p>Ratio of the radiation emitted to the radiation absorbed in energy units.</p> <p>Note: Ratio of the radiation emitted to the radiation incident on the fluorescent material is called the <b>external radiant efficiency</b></p> <p>Symbol: <math>Q(\lambda')</math>, where <math>\lambda'</math> is the excitation wavelength.</p>	<p>(mutatis mutandis)</p> <p><b>External quantum efficiency</b> (of a detector):</p> <p>ratio of the number of elementary events (such as release of an electron) contributing to the detector output, to the number of incident photons, including those reflected by the detector.</p> <p>NOTE The use of the unqualified term “quantum efficiency” always implies external quantum efficiency.</p>
<p><b>Relative spectral distribution of radiant fluorescent emission:</b></p> <p>The fluorescent radiant emission at each wavelength of a fluorescent material expressed as a fraction of the total (*).</p> <p>Symbol: <math>F(\lambda)</math>.</p> <p>(*) The definition of <math>F(\lambda)</math> requires</p> $\sum_{\lambda} F(\lambda) = 1.0$	<p><b>Relative spectral distribution</b> (of a radiant, luminous or photon quantity <math>X(\lambda)</math>) [<math>S(\lambda)</math>]:</p> <p>ratio of the spectral distribution, <math>X_{\lambda}(\lambda)</math>, of the quantity <math>X(\lambda)</math> to a fixed reference value, <math>R</math>,</p> <p>which can be an average value, a maximum value or an arbitrarily chosen value of this distribution:</p> $S(\lambda) = \frac{X_{\lambda}(\lambda)}{R}$ <p>Unit: 1</p> <p>NOTE: <math>X_{\lambda}</math> is also a function of <math>\lambda</math> and in order to stress this, may be written <math>X_{\lambda}(\lambda)</math> without any change of meaning.</p>

### 3. Daylight simulator program

The Daylight simulator will be a toolbox belonging to the Colorimetric eXercise software [5]. This toolbox presents the CIE method for assessing the quality of daylight simulators [2, 3].

Table 1. Colorimetric data related to the daylight-simulator and simulated daylight illuminant, color differences /metamerism indices evaluated in the intermediate computation and final Grade. The numeric data are related to the illuminant C used as simulator for D65 illuminant.

Chromaticity of the simulated illuminant C			$x_{10} = 0.31376, y_{10} = 0.33116$		
Chromaticity of the daylight-simulator			$x_{10} = 0.31033, y_{10} = 0.31919$		
Chromaticity distance between simulated and simulator in $(u'_{10}, v'_{10})$ diagram			0.00733 (allowable range < 0.015)		
<b>Evaluation of the visible region</b>			<b>Evaluation of the ultraviolet region</b>		
metamer	$\Delta E^*_{ab,10}$	$\Delta E^*_{uv,10}$	metamer	$\Delta E^*_{ab,10}$	$\Delta E^*_{uv,10}$
1	0.249	0.414	1	3.825	5.997
2	0.267	0.397	2	3.170	4.975
3	0.208	0.216	3	2.609	4.060
4	0.226	0.361			
5	0.429	0.502			
average	$M_v = 0.276$	$M_v = 0.378$	average	$M_u = 3.202$	$M_u = 5.010$
Grade = B			Grade = E		

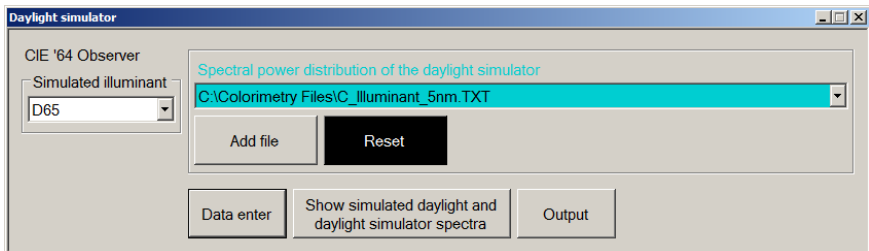

Fig. 8 - Dialogue window of the computer-program toolbox. The user has to choose the simulated illuminant and the spectral power distribution of the corresponding daylight simulator. With "Show simulated daylight and daylight simulator spectra" the spectra of the illuminants are plotted as in shown in Fig. 9. With "Output" the complete computation is shown in the next window reproduced in Fig. 10.

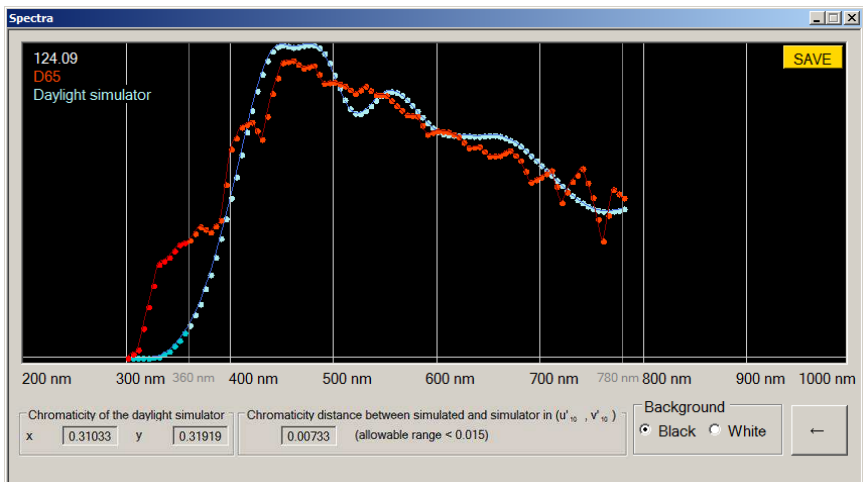

Fig. 9 - Spectral power distribution of the D65 illuminant as simulated daylight and of the C illuminant as daylight simulator.

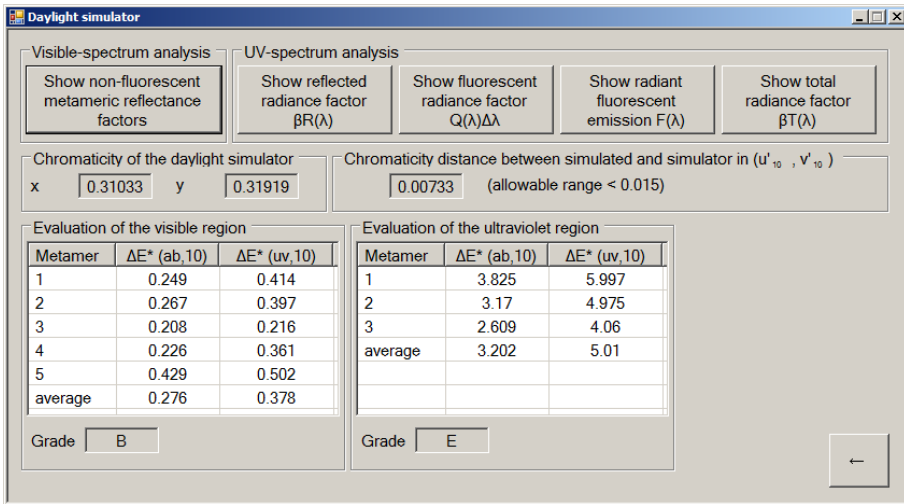

Fig. 10 - Output window of the computer-program toolbox "Daylight-simulator evaluation-Special metamerism index: change in illuminant". Color differences between metameric specimens evaluated in visible and in ultraviolet region, average color-difference values and grade are given.

The user proceeds as follows (Fig. 8):

- (1) Choose the daylight to be simulated (D50, D55, D65 or D75).
- (2) Input from file of the spectral power distribution of the daylight simulator.

The computer program first shows a comparison of the test and reference illuminants (Fig. 1, 9), then makes the computations as shown in Section 2, whereas the result is synthesized in Table 1 and Fig. 10.

## Bibliografia

- [1] CIE Publication 80:1989, *Special metamerism index: change in observer*, Commission Internationale de l'Éclairage, Vienna, Austria (1989). <http://www.cie.co.at/>
- [2] CIE Publication 51.2:1999, *A method for assessing the quality of daylight simulators for colorimetry.*, Commission Internationale de l'Éclairage, Vienna, Austria (1999). <http://www.cie.co.at/>
- [3] CIE Publication CIE S 012/E:2004. *Standard method of assessing the spectral quality of daylight simulators for visual appraisal and measurement of color*, Commission Internationale de l'Éclairage, Vienna, Austria (2004). <http://www.cie.co.at/>
- [4] CIE publication S 017/E:2011. *ILV: International Lighting Vocabulary*, Commission Internationale de l'Éclairage, Vienna, Austria (2011) (<http://eilv.cie.co.at/>)
- [5] C. Olcari, *Standard Colorimetry: Definitions, Algorithms and Software*, John Wiley & Sons, 2016, ISBN 978-1-118-89444-6 (<http://booksupport.wiley.com/>)

# Unified Profiles of Spectral Data to support Spatial and Dynamic Color Designs

<sup>1</sup>Markus Reisinger

<sup>1</sup> Lighting Research Studio, Lucerne, Switzerland, m.reisinger@lightingresearch.eu

## 1. Introduction

Color is an essential characteristic of the man-made architectural environment. All design professions that deal with objects and surfaces, lighting or light emitting elements have to communicate color aspects to realize their ideas. Light emitting diodes (LEDs) extended the scope for light applications significantly. Today we are able to design and realize a broad range of custom light spectra. Their applications within the field of architecture range from retail to healthcare and entertainment.

Several of the established descriptors to characterize color, transmittance of materials or light sources are based on spectral data. This means that designer working with light and color must merge different data formats to allow firm conclusions. In fact, computer screens are doing this in rather simple manner - everything is translated to hardware specific RGB values. Especially dynamic color designs that are triggered by events or time marks are complex to develop. Unified profiles to characterize colors and light are intended to enable an efficient communication of the spectral aspects involved.

Today's practice is that object colors are defined according color systems (e.g. Natural Color System), light sources are categorized according correlated color temperature (CCT) and dominant wavelength. To judge the interaction of object colors and lighting there are additional color rendition descriptors (e.g. color rendering index). A rather complex, but detailed concept to describe color changes in comparison to a reference light is incorporated in the IES TM-30-15 procedure to define color rendition [1]. This description method is like the CCT description restricted to characterize achromatic light. Additionally it requires calculations for a large set of reflectance values. For many color designs it is sufficient to check selected combinations instead of a full set of predefined samples.

There are several reasons why choosing colors to fit a concept is a delicate task. One hurdle is that language to characterize colors only poorly aligns with the metrics used. Spectral data contains a wealth of information, but it requires specific knowledge for correct interpretation. The proposed method to ease communication builds on insights that color naming and the concept of unique hues align well with each other [2].

## 2. Unified Profiles to describe spectral data

Spectral data is required to describe light source characteristics and properties of surfaces. Electromagnetic radiation between 380nm and 780nm is considered as

visible light. In radiometry, photometry and color science the spectral power distribution is used to characterize the illumination as amount of energy per unit area and per unit wavelength. The spectral distribution of the light emitted influences the appearance of objects. The color of an object is a result of what parts of the spectrum are reflected, absorbed and transmitted. When light sources are shielded from direct viewing all light the eye receives is reflected light (see Figure 1). The basic idea behind the method introduced is that unified profiles are used to describe the spectral characteristics at all stages from light emitters to reflecting surfaces and the light received by the eye.

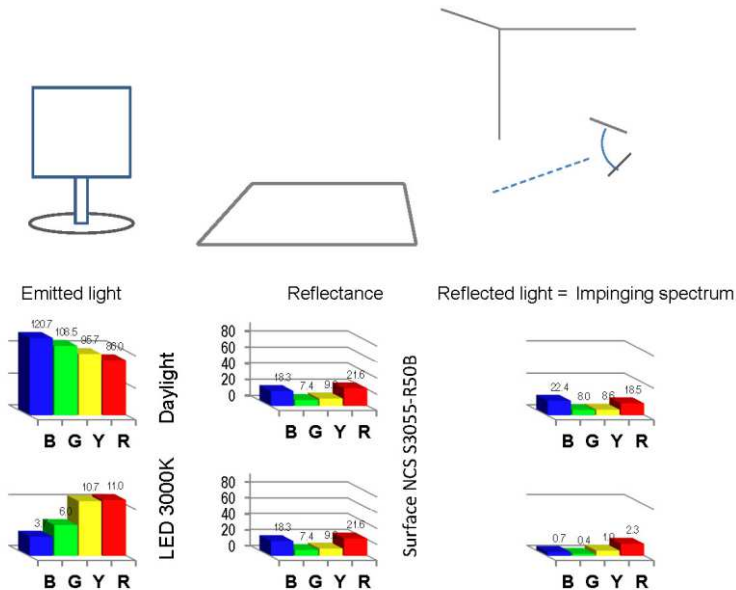

Fig. 1 - Characterization of the impinging spectrum in case of daylight illumination and in case of usage of 3000K LED light sources. Spectral data is represented in four wavelength bands: blue, green, yellow and red.

Reflectance is the ratio of the reflected light to the total amount of light incident on that surface. Dark materials may reflect less than 10% of the light and very bright materials up to 90% of the incident light. Spectral data for light sources and for surface reflectance are in general presented in form of diagrams with wavelength on one axis and energy or energy ratios on the other (see examples in Figures 2 to 4). These diagrams represent well the physical data, but are cumbersome to verbalize. The profiles introduced here summarize spectral data in a format that is also for laymen easy to communicate. Gall and Lapuente [3] defined bands of wavelength with the aim to assist selection of suitable lamp spectra. To describe radiation between 380nm and 720nm they used 6 spectral bands: purple, blue, green, yellow, orange and red. The chosen intervals were within the range of 23nm (yellow) and 93nm (red). To meet the objective to ease communication for design purposes in this approach the spectrum



was split in accordance to the principle of unique hues [4]. This well-established way to categorize colors is for example used in the Natural Color System (NCS). Starting point for defining four slices in wavelength space was the precondition to locate the yellow band around 576nm (compare Lillo, Moreira et al. [5]). A heuristic strategy was employed to define wavelength bands for red, blue and green. There was no obvious objection to use the same bandwidth for all four bands. Hence four bands of 53nm width (see Table 1) were defined. The resulting range represents well conditions for which color vision seems to function at its best [6].

Tab. 2 - Definition of the Spectral Profile with its 4 spectral bands.

<b>Band</b>	<b>Wavelength range</b>
B: Blue	444nm – 496nm
G: Green	497nm – 549nm
Y: Yellow	550nm – 602nm
R: Red	603nm – 655nm

Profiles with the mentioned characteristics can be easily derived from spectral data by calculating the average of all values within each band. Independent of the profile type all profiles share the same structure. Values for emitted light and light that travels towards the observer are expressed in  $W/(m^2 \text{ nm})$ , reflectance values are expressed as percentage.

### **3. Unified profiles applied to describe reflecting surfaces and light emitters**

The following examples demonstrate how to apply unified profiles. The profiles are generated from data describing the spectral distribution in the range between 444nm and 655nm. The profiles represent radiometric data, therefore neither information about cone response or luminous efficiency is required. As input typically measurements of spectrophotometers, or spectrometers are used. The examples for reflection spectra shown in Figure 2 are the most saturated NCS samples for blue, green, yellow and red hues. It is easy to recognize that the yellow sample is the brightest of all. It reflects wavelength above 540nm and additional also a considerable amount of the radiation between 500nm and 540nm. This characteristic is also represented in the profile, columns for red and yellow are tall, additional is some green contribution to recognize, but practical no blue contribution. The profile for the red surface shows most clearly a case that all reflected light fits in one spectral band (603nm - 655nm). This means that when this sample is illuminated with either green or blue light it will appear black.

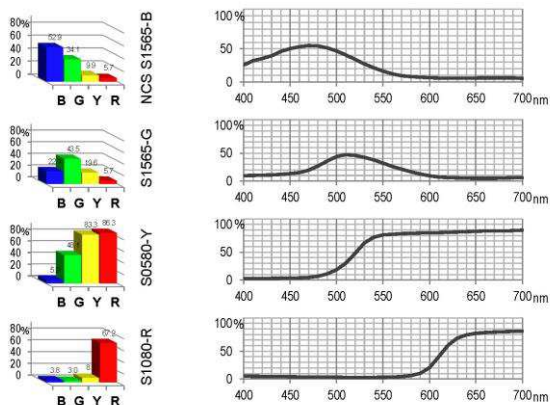

Fig. 2 – Unified profiles and spectral distribution of reflectance data for 4 NCS samples representing the unique hues.

Most achromatic LED light sources available today use phosphors for color conversion. Two typical spectra for such LED sources are shown in Figure 3. The profiles on the left shows the difference that the first source contains more blueish light than the second source. Looking at the CCT of both sources than this was exactly to expect. The third source is a halogen lamp which typical emphasizes warm tones. Generally, all achromatic light sources with good color rendering characteristics will show a balanced profile, either with emphasis on the red part or the blue part (like daylight).

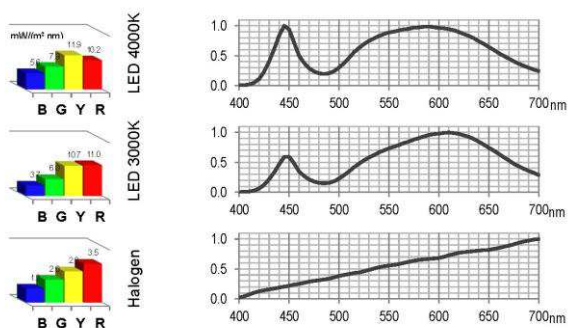

Fig. 3 – Unified profiles and spectral distribution of two achromatic LED and one halogen light source.

LEDs are not only efficient light sources they also excel in providing highly saturated colors. The impression of very pure chromatic light is caused by a very narrow band of light emission. Figure 4 shows next to the corresponding profiles the emission spectra of four chromatic LEDs: blue, green, yellow and red. The wavelength of the

emitted light is dependent on the used semiconductor material. In comparison to the spectra shown before, the bandwidth can be quite narrow.

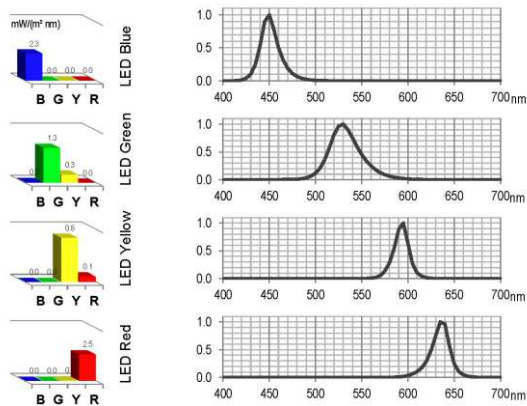

Fig. 4 – Unified profiles and spectral distribution of 4 chromatic LED light sources.

By combining LEDs with different dominant wavelength it is possible to realize almost any light spectrum. To design spectral characteristics of light sources has become a reality. To describe color characteristics of multicolor LED luminaires is one of the application fields for unified profiles. The profiles can also be used to distinguish metameric matches or sources with same CCT but different spectra. As unified profiles can also represent spectral energy that enters the eye the profiles may provide a solution to describe conditions causing chromatic adaptation.

#### 4. Conclusions

The proposed approach of unified profiles of spectral data is focused on efficient communication and therefore accepts abstraction to four wavelength bands. As a result, it is nearly as simple as a trichromatic system, but fits more accurately human perception and established communication practice. The elegance of the solution lies in the fact that profiles of spectral data are derived from physical measurements, but align at the same time with notions used for everyday color communication.

Defining dynamic color scenes can be cumbersome. A compact way to describe spectral aspects of scenes and color combinations is considered to make handling easier. Designer from various disciplines need to define spectral characteristics to transform the natural environment with the purpose of adapting it optimal to human life. What future work has to prove is that compression to profiles with four bands is accurate enough to characterize color in spatial and dynamic color concepts.

## References

- [1] David, A., et al., *Development of the IES method for evaluating the color rendition of light sources*. Optics Express, 2015. 23(12): p. 15888-15906.
- [2] Witzel, C., F. Cinotti, and J.K. O'Regan, *What determines the relationship between color naming, unique hues, and sensory singularities: Illuminations, surfaces, or photoreceptors?* Journal of Vision, 2015. 15(8): p. 19-19.
- [3] Gall, D. and V. Lapuente, *Beleuchtungsrelevante Aspekte bei der Auswahl eines förderlichen Lampenspektrums*, in *Licht2002*. p. 860-871.
- [4] Valberg, A., *Unique hues: an old problem for a new generation*. Vision Research, 2001. 41(13): p. 1645-1657.
- [5] Lillo, J., H. Moreira, and N. Gómez, *Reflectance and Energetic Imbalance: Colourimetric Evaluation of the NCS Colour Atlas*. Psicológica, 2002. 23(?): p. 209-231.
- [6] Romney, A.K. and R.G. D'Andrade, *Modeling lateral geniculate nucleus cell response spectra and Munsell reflectance spectra with cone sensitivity curves*. Proceedings of the National Academy of Sciences of the United States of America, 2005. 102(45): p. 16512-16517.

# The experience of equivalent luminous colors at architectural scale

<sup>1</sup>Ute Besenecker, <sup>1</sup>Ted Krueger, <sup>2</sup>John Bullough, <sup>1</sup>Zachary Pearson, <sup>3</sup>Robert Gerlach

<sup>1</sup>School of Architecture, Rensselaer Polytechnic Institute, besenu@rpi.edu, krueger@rpi.edu, pearsz@rpi.edu

<sup>2</sup>Lighting Research Center, Rensselaer Polytechnic Institute, bulloj@rpi.edu

<sup>3</sup>Pantochrome, Gerlach Consulting Inc., rob.gerlach@pantochrome.com

## 1. Introduction

The use of colored light in architectural design has increased significantly over the past two decades. Bold colors, for example, are frequently integrated into lighting for façades and public spaces, and subtle tunable solutions are being tested for retail (e.g., color rendering) and health care (e.g., circadian effects).

Perceptual experiments suggest that nominally identical colors (so-called metamers), as defined by chromaticity and luminance, might not be identical in perceived brightness [1] or saturation [2], especially when viewed in a full field-of-view including peripheral photoreceptive mechanisms. Most color metrics used in practice and application are based upon the central visual field of view [3]. In addition, light of different spectral compositions can vary in eliciting non visual physiological responses [4, 5]. We are interested in the architectural relevance of nominally metameric colors when experienced in large-scale conditions with a full-field of view including peripheral vision.

Lighting design for theater and music performance has developed a body of knowledge for the creation of sophisticated designs with colored light. In theaters and studios, seven-color light emitting diode (LED) systems are being used increasingly to replace traditional filtered tungsten sources. Three- or four-color LED sources, as used in many architectural color-changing fixtures, have been judged by design professionals as insufficient to produce the desired color range and quality for theatrical and other performance uses [6]. The transition from filtered tungsten sources to multi-emitter LED sources comes with the challenge to color match past projects that are being retrofitted [6, 7]. It also comes with the opportunity to use metameric colors as a new design tool. The technology change also exposed shortcomings for the most common metrics used in industry to measure and match luminous color and light level. Practitioners and manufacturers observe limitations in matches made via color and luminance meters, and are often left with developing color and brightness matches by eye [6, 8].

In order to investigate the differences in the effects of large-scale colors matched for chromaticity and luminance, we designed dedicated experiments in the 50' x 60' x 35' black box studio space of the Experimental Media and Performing Arts Center (EMPAC) at Rensselaer Polytechnic Institute (RPI). Semi-circular wall surfaces (denoted 'tubicles', 9' diameter x 14' height) were built and illuminated with nearly equivalent colors that were mixed using different methods: filtered tungsten, a three-color LED system, and a seven-color LED system, as well as a video projector. In addition, we closely matched the chromaticity of the colored light using paint pigments illuminated by white LED and tungsten light sources.

Using this apparatus, we conducted a series of studies with two hue groups, amber and cyan, using hybrid research methods [9]: a qualitative study (Study 1)

with 17 participants, followed up by a quantitative protocol (Study 2) with 12 participants. The participants experienced the conditions at different vantage points using their full fields of vision. In addition most of the participants (n=29) also participated in separate sessions (Study 3) dedicated to measure blood pressure in response to the lighting conditions.

## 2. Study Approach and Set-up

When viewing nominally equivalent colors with a full field of view, discrepancies in perceived brightness [1] and saturation [2] have been observed. To explore the perceived differences of equivalent colors in architectural-scale spatial settings, we conducted a series of studies.

We built several semi-circular viewing chambers (tubicles) in a black-box studio and created seven nearly equivalent color conditions for amber and cyan respectively that were mixed using different methods. Figure 1 shows the spatial layout in the planning stages.

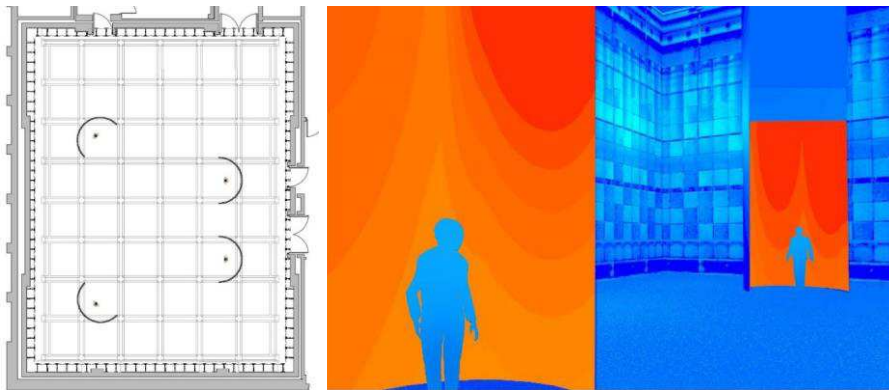

Fig. 1 - Semi-circular viewing chambers (tubicles), size: 9' diameter x 14' height, in a 50' x 60' x 35' black box studio space.

The color conditions for the amber and cyan hue groups were created as follows (with the amber conditions mentioned first, the cyan conditions second):

1. AT or CT: a tungsten source with an amber or cyan color filter on white matte paint
2. ALED or CLED: an amber or cyan LED on white matte paint
3. ARG or CBG: a red + green LED mixture, or blue + green LED mixture on white matte paint
4. ARL or CIR: a red + lime LED mixture, or a red + indigo + cyan LED mixture on white matte paint
5. AP or CP: a digital light processing (DLP) projector red + green mixture, or blue + green mixture
6. APLED or CPLED: a white LED source on amber or cyan paint
7. APT or CPT: a tungsten source on amber or cyan paint

Figure 2 (amber) and Figure 3 (cyan) show the different spectral power distributions (SPDs), scaled for relative light level, of conditions 2-7 in relation to condition 1 (filtered tungsten), which was used as a reference. Figure 4 shows the chromaticity coordinates for all conditions plotted on the 1964 CIE diagram for 10° vision.

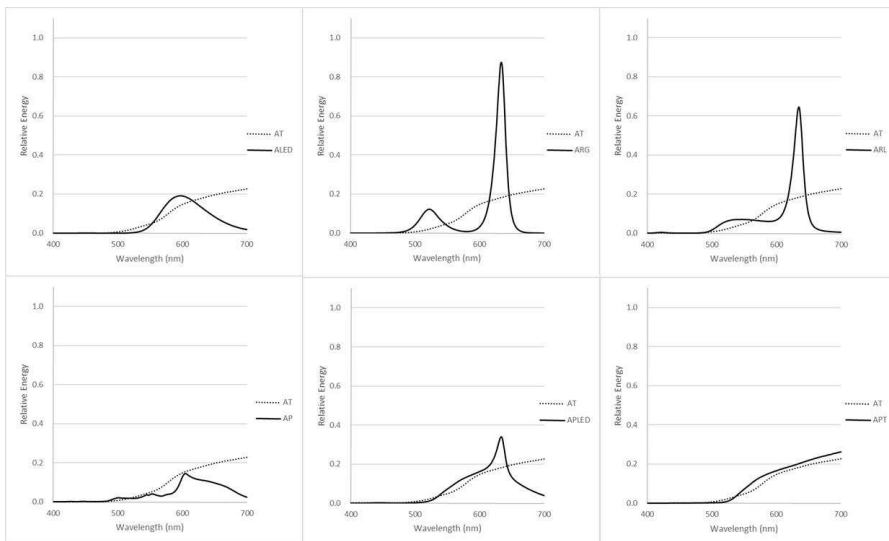

Fig. 2 - Spectral power distributions of amber conditions 2-7 in relation to condition 1 (scaled for relative light level).

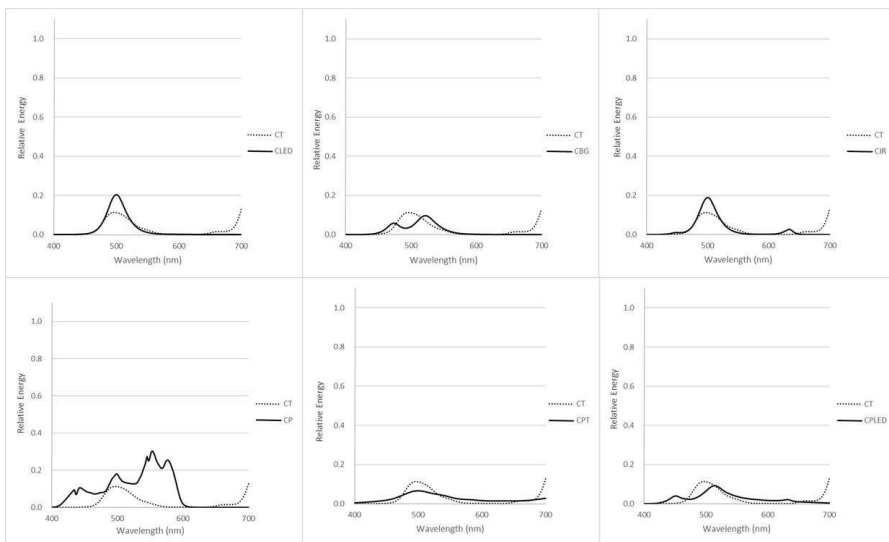

Fig. 3 - Spectral power distributions of cyan conditions 2-7 in relation to condition 1 (scaled for relative light level).

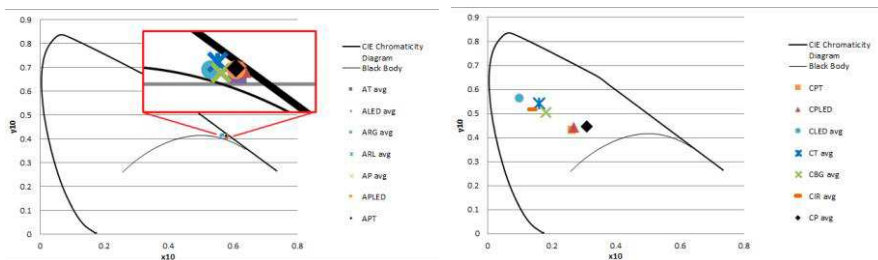

Fig. 4 – Chromaticity coordinates (CIE 1964) for the amber (left) and cyan (right) conditions

Due to the scale of the set-up and the equipment available, the conditions were not exact metamers; they did not match precisely in their chromaticity (see Figure 4). But these are the conditions that are found in the field using currently available technologies and so have ecological validity for architecture and design.

We were interested in how people would evaluate the conditions and whether consistent patterns in responses could be observed. We were particularly interested in the following questions:

- Are there consistent patterns in participants’ comments on perceived differences among conditions?
- Are the differences consistent with or different from the metrics of chromaticity and luminance?
- Are there relationships between responses in different categories (e.g. visual and emotional or spatial qualities)?

### 3. Procedures

Three studies were conducted.

#### 3.1. Study 1

Study 1 was exploratory and qualitative. Seventeen color-normal [10] participants between the ages of 27 – 82 (mean 50 years) participated, ten males and seven females, with varying degrees of expertise in working with light and color. Nine of them work professionally with either light or color: seven as designers and two as photographers.

The participants were free to move around as desired; see Figure 5. Each participant was shown a timed sequence of 13 pairs of illuminated spaces, 2 minutes for each pair, with a 30 second break to reset adaptation of the eyes. They were asked to give any comments and comparisons in response to the color conditions.

Each participant conducted the study with both hue groups, amber and cyan, separately, one in the morning, one in the afternoon. The order of conditions and hue groups were varied for counterbalancing.

All comments, whether written or spoken, were recorded, transcribed and coded into categories: visual qualities (brightness, saturation), emotional qualities (aversion, attraction), and spatial qualities. The results were graphed and produced ranking orders for the different conditions (e.g., bright to dim, saturated to unsaturated).



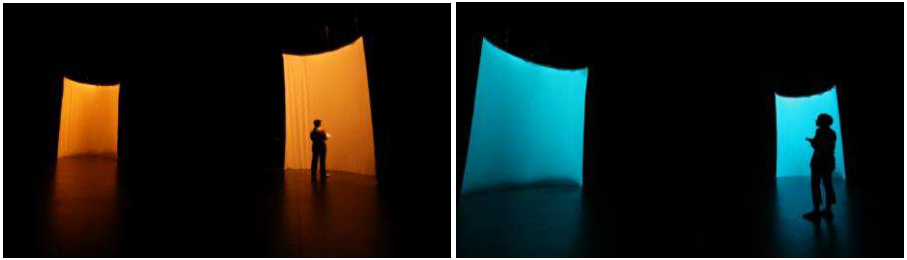

Fig. 5 - Participants evaluating and comparing two amber conditions (left) and two cyan conditions (right)

### 3.2. Study 2

Based on the terms used by the participants in Study 1 to describe the conditions, we conducted a follow-up study (Study 2) two months later using the same lighting conditions. Twelve color-normal [10] participants between the ages of 24 – 65 (mean 43 years), 9 males and 4 females, sat in a fixed location (see Figure 6) and evaluated the conditions using a questionnaire. None of the participants had been part of Study 1. They had varying degrees of expertise in working with light and color. Six of them work professionally with either light or color: two as designers, four as scientific researchers.



Fig. 6 - Participant sitting in the tubicle (left) using a questionnaire (right).

Again, each participant conducted the study with both hue groups, amber and cyan, separately, one in the morning, one in the afternoon. The order of conditions and hue groups were varied for counterbalancing.

### 3.3. Study 3

Study 3 was conducted with participants of Study 1 and 2 in a separate session, sitting immersed in the condition as illustrated in Figure 7. There were twenty-nine participants, all between the ages of 24 – 79 (mean 46 years), with 17 males and 12 females. Blood pressure was measured using an arm cuff at the onset (base line) and for each condition (1.5 minutes of exposure). In between the

conditions the participants were exposed to 30 seconds of darkness to reset adaptation.



Fig. 7 - Participant sitting in the tubicle for blood pressure measurements, amber (left) and cyan (right).

#### 4. Results

Study 1 produced a rich variety of comments, such as: *“Oh! That is very much more cheerful. I don’t know why. It doesn’t look that different, but it seems more cheerful. When you are in it feels more like it is difficult to balance. Try to stand on one leg. Hehehe. This is leathery. I could knit myself up in there though.”*

It made individual differences in perception and preference, depending on experience and personality, more apparent. This is illustrated in the below responses of two different participants to the same condition:

Participant #16: (Laugh) *“Oh, wow, now that gets me excited. On the right. Oh my gosh. That’s a happy color! Hah! Oh my lord. Nice contrast here.”*

Participant #7: *“That’s very bright and very light. Almost translucent. It’s back to upsetting. A group that’s upsetting. Unstringing. It makes me breathe hard.”*

In addition, group differences were detected in Study 3. There was a statistically significant effect of gender and age ( $p < 0.05$ ) for the blood pressure measurements in response to the color conditions.

While individual differences could be observed, there were also reliable average patterns in the study results. For Studies 1 and 2, all results were organized in categories of visual qualities (brightness and saturation), emotional qualities (attraction), and spatial qualities (spaciousness).

Results from both experimental sessions, Study 1 and Study 2, suggested that people consistently were aware of qualitative differences of nearly equivalent conditions at large scale for both hue groups, amber as well as cyan. This held true not only when observers were seated in one location and instructed to fill out a questionnaire (Study 2), but also when walking around comparing conditions from different locations (Study 1).

Differences in perceived brightness were distinct and significant, and the brightness perception results were predicted slightly better using a provisional scene brightness model [11] than luminance, the industry standard.

Also, while differences in chromaticity were small, especially for the amber conditions, the differences in perceived saturation were relatively large.

Focusing on the three LED sources only (ALED, ARG, ARL (amber) or CLED, CBG, CIR (cyan)) suggests that the perceived visual differences in brightness and saturation between the narrowband LED condition (amber LED (ALED) or cyan LED (CLED) respectively) and the 3-color source LED condition (red+green LED (ARG) or green+blue LED (CBG) respectively) were reliable ( $p < 0.05$ ). However, the perceived differences in brightness and saturation between the 7-color source LED condition (red+lime LED (ARL) or red+indigo+cyan LED (CIR) respectively) and the other two LED conditions (ALED and ARG, or CLED and CBG respectively) were not.

This suggests that when matching luminous colors in spatial environments, options beyond narrowband RGB sources can provide closer matches. In addition, these can also offer a variety in color rendering properties which might be useful for design applications [6].

In addition to exploring the differences between the luminous color conditions, the studies showed differences between luminous color and illuminated colored paint (illuminated color). The illuminated color conditions were evaluated as similar to the luminous color (colored light on white paint) when viewing them from farther away (Study 1), without being immersed or covering the full-field of view. The participants did not notice that it was not the light that was colored. From close-up, immersed in the condition (Study 1 and 2), there were, however, differences, as described in the quotes below:

Participant #10: *“initially seems similar, but after looking at paper - seems almost grey / more dull and memory of other wall impact is more vivid”.*

Participant #16: *“They both seem pretty similar, but the one on the right seems more saturated and luminous. And the one on the left, it feels more integrated with the fabric, and it appears less luminous. And... then when you get up close and it's the only thing around you it feels pretty saturated. Proximity changes some of the effect of the color. They're quite the similar hue, and now I do realize that that's actually painted.”*

The illuminated color retained saturation, while the luminous color conditions desaturated (likely due to chromatic adaptation [12]). This was especially apparent in the results for the cyan hue group, because chromaticity predicted that the cyan paint condition would look less saturated than the cyan light conditions. The above observation suggests that with the increasing use of colored light in architectural environments, more detailed perception studies into full-field chromatic adaptation would be useful to inform design applications.

One of our objectives was to learn about possible relationships between the perceptions of visual, emotional and spatial qualities, and, as well, physiological measures (blood pressure). Therefore, after coding all results into such categories and creating interval rankings, we correlated the results. The statistically significant correlations ( $p < 0.05$ ) are summarized in Figure 8.

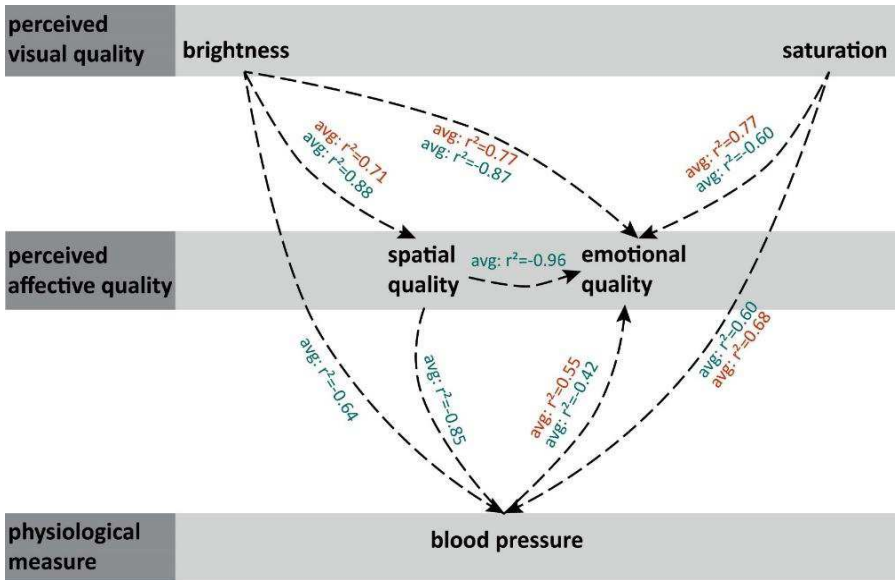

Note: Dashed lines and arrows show reliable correlations.

Fig. 8 – Significant correlation between the participant responses according to categories for amber and cyan

The perception of brightness was correlated with perceived spatial and emotional qualities for both hue groups, amber and cyan. Brighter conditions seemed preferred and appeared more spacious than dimmer ones. For the cyan condition brightness was also correlated with blood pressure.

The correlations also suggest that for the amber conditions a higher saturation was evaluated as more attractive and preferred. For the cyan conditions, however, the correlation was negative: less saturated was preferred. Saturation was also correlated with blood pressure for both hue groups: higher saturation coincided with a higher blood pressure.

In addition, blood pressure was correlated with emotional quality for both, amber and cyan; for cyan it was also correlated with how spacious a condition appeared.

## 5. Summary

For cyan and amber conditions that were matched closely for chromaticity and luminance, participants reported reliably perceived differences between conditions in saturation and in brightness (reliable average trend); these differences were larger than predicted by the industry metrics in common use (luminance, chromaticity). Participants also reported differences between the nominally similar conditions in emotional and spatial qualities (reliable average trend). In addition, there were correlations between visual qualities, spatial, emotional qualities and measured blood pressure.

This confirms observations from field practice that the metrics and tools currently used to match luminous colors do not provide satisfying matches when used for large-scale set-ups.

Furthermore, the results suggest that participants are able to pick up subtle differences, and evaluate nearly equivalent colors differently depending on spectral composition. This can inform design practice when choosing the technologies and tools to implement color into spatial designs.

In addition to the average patterns, transcribed qualitative responses and associations substantiated the average trends while also adding information about individual variations between the different participants.

## Acknowledgements

The authors thank the Experimental Media and Performing Arts Center (EMPAC) and the Jaffe Student Production Competition, the HASS Fellowship Fund, the Light Enabled Systems and Applications, the Lighting Research Center and the School of Architecture at Rensselaer Polytechnic Institute for their support and contributions, and Golden Artist Colors, ETC Lighting and Controls and Philips Color Kinetics for equipment and advice.

We also would like to thank Kenneth Appleman, Meeghan Appleman, Jonas Braasch, Tomie Hahn, Michael Oatman, and Alicia Walf for their input and help, as well as everybody who participated in or helped with the interviews and perception experiments for their invaluable insights.

## Bibliography

- [1] U. C. Besenecker; Bullough, J. D., "Investigating visual mechanisms underlying scene brightness," *Lighting Research and Technology*, vol. 0, pp. 1-17, 2016.
- [2] R. Gerlach, "Leds to light the theatre," *Theatre design and technology*, vol. 39, pp. 11-23, 2003.
- [3] P. Boyce, *Human factors in lighting (2nd Edition)*. London, UK: Taylor & Francis, 2003.
- [4] C.-J. Choi; Kim, K.-S.; Kim, C.-M.; Kim, S.-H.; Choi, W.-S., "Reactivity of heart rate variability after exposure to colored lights in healthy adults with symptoms of anxiety and depression," *Int J Psychophysiol*, vol. 79, pp. 83-8, 2011.
- [5] S. W. Lockley; Evans E. E.; Scheer, F. A. J. L.; Brainard, G. C.; Czeisler, C. A.; Aeschbach, D., "Short-wavelength sensitivity for the direct effects of light on alertness, vigilance, and the waking electroencephalogram in humans," *Sleep- New York then Westchester*, vol. 29, p. 161, 2006.
- [6] C. Taylor, Broadway and Theatre Lighting Design, "Phone and in-person conversation: Light and Color," U. C. Besenecker, Ed., ed, 2015.
- [7] L. Schwendinger, Urban Lighting Design and Light Art, "In-person conversation: Light and Color," U. C. Besenecker, Ed., ed, 2015.
- [8] R. Gerlach, LED Fixture Development, "Personal phone conversation: Light and Color," U. C. Besenecker, Ed., ed, 2015.
- [9] U. C. Besenecker; Krueger, T., "Luminous color in architecture: Exploring methodologies for design-relevant research," *Enquiry*, vol. 12, pp. 35-46, 2015.
- [10] S. Ishihara, *Tests for colour-blindness. 24 plates edition*. Tokyo, Japan: Kanehara Shuppan Co Ltd., 1963.
- [11] U. C. Besenecker; Bullough, J. D., "Progress in modelling scene brightness," presented at the CIE 2015 Annual Conference, Manchester, UK, 2015.
- [12] M. D. Fairchild, *Color appearance models*: John Wiley & Sons, 2013.



## **4. COLOUR AND PSYCHOLOGY**





# Variational achromatic induction and beyond

<sup>1</sup>Giorgio Gronchi and <sup>2</sup>Edoardo Provenzi

<sup>1</sup>Università degli Studi di Firenze (Italy), giorgio.gronchi@gmail.com

<sup>2</sup>Université Paris Descartes (France), edoardo.provenzi@parisdescartes.fr

## Abstract

Starting from a variational analysis of the so-called Rudd-Zemach model of achromatic induction, we will provide a theoretical model that can be also applied to context-driven higher level cognitive features.

The key ingredient of the model is the balance between assimilation and contrast, which we show to be one of the basic features of color perception. In the case of contrast, judgments and contextual information are negatively correlated; on the contrary, in the case of assimilation, there is a positive correlation between the judgment and the contextual information.

The balance between them can be interpreted in a variational sense. Multiple examples and discussions are presented to support the model.

## 1. Introduction

Psychological literature often makes a parallel between the processes and the mechanisms of perception and cognition. However, this parallelism often lacks of a rigorous mathematical analysis.

The starting point of this work is the famous Wallach's experiment on simultaneous contrast [18]. This is a classical experiment about the induction phenomenon that shows how the surround of a stimulus alters the perception of its luminance. More recent psycho-physical data obtained by Rudd & Zemach [13] have proven that the simple mathematical explanation given by Wallach is not satisfying and they updated the theory by introducing techniques coming from edge integration models, in particular the famous Retinex model of color perception by Land and McCann [7]. Provenzi [12] showed that the Rudd and Zemach model can be embedded in a variational framework, i.e. their equations can be found by the minimization of a functional.

Interestingly, this functional is given by the sum of two terms in opposition: the first term is called *assimilation* (or dispersion) and its minimization tends to assimilate the stimulus to the average of the surround, thus decreasing the information content of the global scene; the second term is called *contrast* and its minimization tends to intensify the difference between stimulus and surround, which instead has the effect of augmenting the informative content.

As proven in Provenzi [12], the optimal balance between these two conflicting actions turn out to be the Rudd and Zemach model.

Contrast effects driven by the surround can be observed also in other domains beyond simple perceptual tasks. We can define a contrast effect as an overrate or underrate evaluation of a stimulus when there is a simultaneous, temporal or spatial,

presentation of a context with a lower or greater value, respectively, in the same dimension of the stimulus compared to the same task performed in isolation.

Given this definition, the contrast effect regards judgments or estimation that go beyond simple perceptual task. For example, it can be observed in perceptual tasks where top-down influence can be stronger (such as the perception of beauty when judging faces), or more cognitive-oriented tasks, such as preference judgments.

To give an example within the domain of perception of beauty, let us consider a face that is judged neither particularly beautiful nor ugly in isolated conditions. If the same face is judge together with a set of particularly attractive faces, it will be judged less beautiful. On the contrary, if the very same face is judged together with a set of particularly ugly faces, it will be judged more beautiful compared to the judgment in isolation [15].

The same holds for tasks usually related to higher-level cognition ([1], [5], [8], [10], [11]). In particular, the study of Parducci [11] about moral judgment asked to rate the gravity of acts, such as “*Habitually borrowing small sums of money from friends and failing to return them*”, when accompanied with very serious bad acts such as “*Using guns on striking workers*” or trivial acts such as “*Cheating at solitaire*”. Of course, he found that in the latter “*Habitually borrowing small sums of money from friends and failing to return them*” was judged more grave compared to the former case.

Finally, the contrast effect regards also performance in conditioning paradigms (see, for example [4]). It’s important to note that contrast effects belong to more general context-driven phenomena. The counterpart of contrast effect is assimilation in which we have that luminance appearance shifts toward that of the surrounding regions ([3], [6]). In higher-level cognition, the most famous example of assimilation is anchoring ([14], [16]).

So, in this paper we aim to extend the formal analysis already done in the domain of achromatic induction to propose a more general theory of context-driven phenomena that can also be applied to cognitive tasks. The main advantage of our formal analysis is that it can be used to make novel accurate predictions about contrast effects that can be tested and tuned by devising new empirical tests.

The paper is structured as follows. First, we will briefly review Wallach's task displaying the different formal models that have been proposed in order to account for this phenomenon. Secondly, we will describe the meaning of our formal model about contrast effect and we will discuss the possibility to apply it to higher level cognitive phenomena.

## **2. Measure of achromatic induction and its variational interpretation**

Human visual perception is not determined only by the luminance of an object surface, but also by that of the surrounding objects. This phenomenon is called *induction*, to stress the fact that visual perception is induced (and altered) by its surround. What just stated is valid both for skotopic and photopic vision.

Skotopic vision refers to luminance stimuli so dim that only the rod photoreceptors are excited, in this situation we perceive only shades of gray and the induction phenomenon is defined to be *achromatic*. Photopic vision, instead, is related to luminance stimuli bright enough to saturate the rods and excite the three cone photoreceptors responsible for color vision, for this reason, in this case, induction is called *chromatic*.

The most elementary example of induction is the *simultaneous contrast* phenomenon, depicted in Fig. 1: the inner squares have exactly the same luminance, however we perceive them very differently because we are strongly influenced by their distinct surrounds.

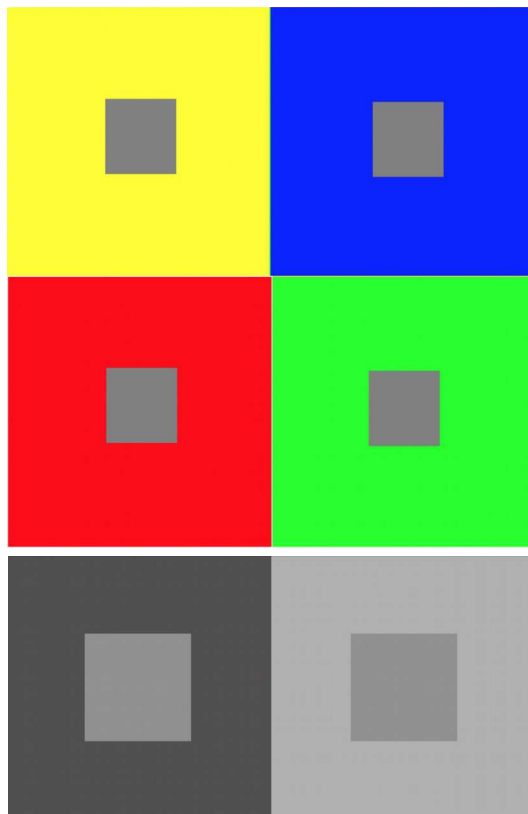

**Fig. 1:** Top: Chromatic simultaneous contrast.  
Bottom: Achromatic simultaneous contrast.

While measures of chromatic induction are still difficult to carry on, achromatic induction has been measured through psychophysical experiments. The first quantitative measure of achromatic induction has been performed by H. Wallach in 1948, see [18]. In his classical experiment depicted in Fig. 2, Wallach considered two disks, T and M for *Target* and *Match*, embedded in black background  $B$ , with luminance  $D_T$  and  $D_M$ , surrounded by two rings of luminance  $R_T$  and  $R_M$ , respectively.

He showed this configuration to a set of observers adapted to the light condition of a dimly illuminated room keeping  $D_T$  and  $R_M$  fixed, using  $R_T$  as an independent variable that he could fix in every experiment, and  $D_M$  as a dependent variable that the users could adjust in order to achieve a perceptual match between the two disks T and M.

Notice that the luminance values selected fall in the scotopic (nearly mesopic) range, to assure that only achromatic stimuli are generated.

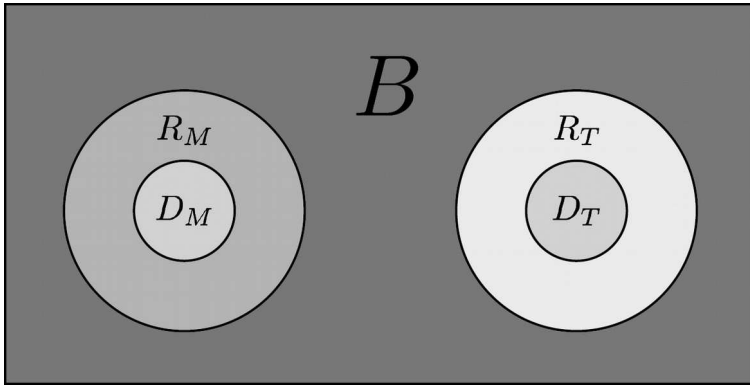

Fig. 2: Wallach's classical experiment. The background is depicted as a shade of gray for visualization purposes.

If the luminance of the surrounding rings failed to influence the perception of the achromatic color of the disks, then the match among the two disks would be simply the *photometric match*, i.e.  $D_M = D_T$ , instead Wallach found that a fairly good achromatic color match among the two disks was obtained when the ratios between the disk and the ring luminances were identical on the two sides of the display, i.e.  $D_M / R_M = D_T / R_T$ , a formula called *Wallach's Ratio Rule*.

By taking the Briggs (decimal) logarithms at both sides and solving for  $D_M$  we find:

$$\log D_M = \log D_T + \log R_M - \log R_T$$

Thus, according to Wallach's Ratio Rule, the plot of the perceptual match in the plane of coordinates  $(x, y) = (\log R_T, \log D_M)$  should be a straight line with slope -1, against the slope 0 that a photometric match would measure. More recent measures on the classical Wallach's experiment show that this slope is actually between -1 and 0, as reported by Rudd and Zemach in [13].

Notice that, with respect to Wallach's ratio rule, these measures show that humans tend to under-estimate  $\log D_M$  for low intensities of  $\log R_T$ , over-estimate it for high intensities of  $\log R_T$ , and to agree with it for medium intensities.

To account for these new psychophysical data, Rudd and Zemach have proposed a more sophisticated model than that of Wallach's. In particular, they weighted the different areas of the visual field with weights that decrease as a function of the distance to the center:  $w_1 > w_2 > \dots$ , i.e.  $w_2/w_1 < 1$ , and so on.

Rudd and Zemach call their model of achromatic induction “*Weighted Log Luminance Ratio*”, or WLLR for short. If WLLR were the true model of achromatic induction, then an observer would match the brightness (perceived luminance) of the disks  $D_M$  and  $D_T$  of Fig. 2 when this equation holds:

$$w_1 \log D_M / R_M + w_2 \log R_M / B = w_1 \log D_T / R_T + w_2 \log R_T / B,$$

solving this equation w.r.t.  $\log D_M$  we have

$$\log D_M = \log D_T + (1 - w_2/w_1) \log R_M - (1 - w_2/w_1) \log R_T.$$

The WLLR model thus predicts that if we plot the Log of observer's matching disk settings versus the Log of the test ring luminance, the data should fall on a straight line having a slope  $-(1 - w_2/w_1) \in (-1, 0)$ , which is coherent with Rudd and Zemach's observations.

Recently, a variational interpretation of Rudd-Zemach's model has been proposed in Provenzi [12]. Variational principles amounts to define a suitable energy functional, i.e. an integral function, whose minimum is attained when the so-called *objective function* is found. In our setting, the objective function is the perceived luminance. Without entering in the details of the variational model, we can state the core result of Provenzi [12] as follows: the Rudd-Zemach's observations about luminance match in Wallach's experiments can be described by the minimization of the functional

$$E_w(\log L) = 1/2 \int_D (\log L(x))^2 dx - 1/4 \iint_{D^2} w(x, y) \log(L(y)/L(x))^2 dx dy,$$

where  $w$  is the weight of achromatic induction, the continuous version of Rudd and Zemach's weights,  $L$  is the perceived luminance and  $D$  is the spatial domain of the visual scene.

It can be noticed that, in order to minimize  $E_w(\log L)$ , the first term (called *term of assimilation* or dispersion) must be minimized, which forces  $\log L$  to be pushed towards the constant value 0, or, equivalently,  $L$  towards the constant 1, the absolute value is not important (because it can be renormalized via a global scale factor), what is important is that this corresponds to a uniform information. Instead, due to the presence of the minus sign, the second term (called *contrast term*) must be maximized (in order to become as negative as possible), which corresponds to increasing the difference among the perceived luminances.

Of course, this describes a *conflicting mechanism*, which corresponds to the balance between the two opposite actions just described. This gives a concrete example of the existence of two conflicting actions whose balance is in accordance with psychophysical measures.

It is important to stress the meaning of these two terms in terms of information content. The minimization of the assimilation term reflects the minimization of the informative content of the scene. In other words, when this term is small the final percept pulls toward a uniform scene, which has a low information content. Thus, we can interpret the assimilation term as an inhibition one. Instead, the minimization of the second term tends to amplify the information content of the scene, for this reason we can interpret it as an excitation term.

The simultaneous presence of both terms is essential: without the opposition of the dispersion-inhibition term, the contrast-excitation term would blow-up the information content. Vice-versa, if only the dispersion-inhibition term would be allowed to work without the contrast-excitation one, then the stimulus would be assimilated to the surround and the informative content would become trivial.

### 3. New predictions in high-level cognitive tasks

We deem very interesting the challenge to test if the edge integration model and its variational interpretation are not limited to psychophysics of visual perception but they can be also applied (possibly with suitable parameter adjustments) to make accurate predictions in other domains of psychology. The interest comes from the

fact that the role of context is crucial in taking decisions, making judgments and, more generally, evaluating stimuli [2][9][17].

The variational model discussed in the previous section assumes that the effect of the context (represented by the ring that surrounds the disk in Wallach's experiment) decreases as the distance between the context and stimulus increases.

Mathematically, this means that, if we consider (as in Rudd-Zemach's model)

discrete weights  $w_n$ ,  $n = 1, 2, \dots$  to express the influence of the surround on the stimulus, we must find  $w_{n+1} < w_n$  for every  $n = 1, 2, \dots$ . If, instead, we consider (as in the variational model) continuous weights represented by a function  $w$  of two or more variables, then we must find that the function is decreasing with the distance from the stimulus.

It is natural to expect that this assumption holds true also in higher level cognition phenomena, because a larger spatial or temporal distance between the stimulus and the context tends to reduce the contrast effect in judgments related to perception of beauty or in moral judgments, to quote but two examples. Even if this property is reasonable in higher-level cognition, it must be explicitly verified with empirical data coming from dedicated experiments.

#### 4. Discussion and conclusions

We have discussed the so-called weighted edge integration model that can explain empirical data about achromatic induction. We have also discussed an interpretation of this model through variational principles, which allows to put in evidence the fact that achromatic induction can be described as an optimal balance between inhibition and excitation, in the sense rigorously explained in the paper.

Achromatic induction belongs to the category of context-dependent phenomena, such as other higher-level cognitive phenomena as beauty perception or moral judgments, to quote but two.

We hope that this paper can motivate the design of new psychological experiments to check the applicability of weighted edge integration models and their variational interpretation to a broader set of higher-level cognitive phenomena, resulting in a powerful multidisciplinary interplay between applied mathematics and psychology.

## Bibliography

- [1] Anderson, N.H., "On the role of context effects in psychological judgment", *Psychological Review*, 82, 462-482, 1975.
- [2] Beckstead, J., "Modeling sequential context effects in judgment analysis: A time series approach", *Judgment and Decision Making*, 3, 570-584, 2008.
- [3] Blakeslee, B., & Court, M. E., "A unified theory of brightness contrast and assimilation incorporating oriented multiscale spatial filtering and contrast normalization", *Vision Research*, 44 (21), 2483-2503, 2004.
- [4] Bower, G. H., "A contrast effect in differential conditioning. *Journal of Experimental Psychology*", 62 (2), 196-199, 1961.
- [5] Duncan, O. D., & Schuman, H., "Effects of question wording and context: An experiment with religious indicators", *Journal of the American Statistical Association*, 75, 269-275, 1980.
- [6] Gilchrist, A., Kossyfidis, C., Bonato, F., Agostini, T., Cataliotti, J., Li, X., Spehar, B., Annan, V., & Economou, E., "An anchoring theory of lightness perception". *Psychological Review*, 106 (4), 795-834, 1989.
- [7] Land, E. H., & McCann, J. J., "Lightness and Retinex Theory", *Journal of the Optical Society of America A*, 61 (1), 1-11, 1971.
- [8] Marsh, H. W., & Parducci, A., "Natural anchoring at the neutral point of category rating scales", *Journal of Experimental Social Psychology*, 14, 193-204, 1978.
- [9] Matthews, W. J., & Stewart, N., "Psychophysics and the judgment of price: Judging complex objects on a nonphysical dimension elicits sequential effects like those in perceptual tasks", *Judgment and Decision Making*, 4 (1), 64-81, 2009.
- [10] McGarvey, H. R., "Anchoring effects in the absolute judgment of verbal materials", *Archives of Psychology*, 281, 5-86, 1943.
- [11] Parducci, A., "The relativism of absolute judgments", *Scientific American*, 219, 84-90, 1968.
- [12] Provenzi, E., "Achromatic induction: A variational interpretation of Rudd-Zemach's edge integration model", *Proceedings of the 9th International Conference on Signal Image Technology, Workshop on Color and Multispectral Imaging, IEEE*, 424-429, Kyoto, Japan, 2-5 December, 2013.
- [13] Rudd, M. E., & Zemach, I. K., "Quantitative properties of achromatic color induction: An edge integration analysis", *Vision Research*, 44, 971-981, 2004.
- [14] Sherif, M., Taub, D., & Hovland, C. I., "Assimilation and contrast effects of anchoring stimuli on judgments", *Journal of Experimental Psychology*, 55, 150-155, 1958.
- [15] Thornton, B., Maurice, J., "Physical attractiveness contrast effect and the moderating influence of selfconsciousness", *Sex Roles*, 40, 370-392, 1999.
- [16] Tversky, A., & Kahneman, D., "Judgment under uncertainty: Heuristics and biases". *Science*, 27, 1124-1131, 1974.
- [17] Vlaev, I., & Chater, N., "Context effects in games: Local versus global sequential effects on choice in the prisoner's dilemma game", *Judgment and Decision Making*, 2, 380-389, 2007.
- [18] Wallach, H., "Brightness constancy and the nature of achromatic colors", *Journal of Experimental Psychology*, 38 (3), 310-324, 1948.



# LED light scenes for artworks colour perception

<sup>1</sup>Laura Bellia\*, <sup>1</sup>Francesca Fragiasso, <sup>2</sup>Emanuela Stefanizzi,

<sup>1</sup>Department of Industrial Engineering, University of Naples Federico II, Naples, Italy

<sup>2</sup>Department of Industrial Engineering, University of Salerno, Fisciano, Italy

\*Corresponding author e-mail: [laura.bellia@unina.it](mailto:laura.bellia@unina.it)

## 1. Introduction

Lighting quality plays a fundamental role in the perception of spaces and objects. Indeed, in order to guarantee a comfortable and pleasant luminous environment, colour aspects cannot be neglected.

This issue is particularly relevant in the field of cultural and architectural heritage valorisation. Indeed colour is one of the means to communicate artworks meaning, especially considering two-dimensional pieces as paintings, tapestries, frescos, mosaics and some marble works (e.g. parts of altars or decorative floor). When lighting three-dimensional artworks, it is fundamental to consider light influence on shapes perception, shadows effects and chiaroscuro definition. Sculptures are often monochromatic and, consequently, colour perception, despite fundamental in order to exalt materials and shapes, is not so crucial as for two-dimensional pieces. On the contrary, as for the latter case, chromatic ranges can be very wide and the use of colours is a fundamental element of the expressive language. Furthermore, in some cases, the combination of different tones and the use of a specific artistic technique is consciously chosen by artists, in order to obtain the desired colours perception (as for studies connected to impressionism or pointillism)

Colour perception is influenced by different factors: light sources parameters (as Spectral Power Distribution -SPD, Correlated Colour Temperature -CCT, Colour Rendering Index -CRI); environment and objects characteristics; observer's psychological and physiological conditions.

Previous studies [1] [4] [9] focused on the effect on colours perception under different light scenes. Moreover the combination of illuminance level and CCT influences artworks perception and observers level of satisfaction [11]. SPD of the emitted light should be chosen depending on some object characteristics (optical proprieties) and the environment should be considered as well. When considering two-dimensional pieces, lighting design presents specific problems depending on the analysed artworks typology. Specular reflective materials, as oil colours, determine veiling effects. Some materials, as fabrics, are particularly prone to be damaged by UV radiations [2]. Moreover, for paintings or tapestries, it is fundamental to consider the interaction between artwork and environment colours, especially those of the wall to which they are hung up. The importance of the background is such that the European Standard EN 16163-2014 [12] considers it essential in order to give value to artworks and to guarantee their good perception. However, in some cases the interaction with environment is very difficult to control. For example, marble works are generally part of more complex architectural elements (e.g. decorative floors), so it is difficult to distinguish which element is the artwork and which is the background.

Finally users' preferences cannot be neglected. Factors that influence colour perception are not easy to be controlled all together and the use of field tests could

help to investigate their effects on people's preferences and to define guidelines for designers as demonstrated by previous works [7][11].

At the same time LED sources are rapidly spreading, increasing design possibilities, by providing a great range of technical choices. Indeed, these light sources are characterized by high CRI values, various CCTs and, in some cases, for same luminaire the SPD can be changed, according to specific requirements [3][5][6]. Designers should take advantage of the potentialities of this technologies in order to individuate the most suitable luminous scenario, able to enhance artworks, accounting for their characteristics and environmental conditions.

The goal of this paper is to show how colours perception of two-dimensional artworks is influenced by light scenes and settings characteristics and what are the main parameters characterizing the artworks typology and exhibition set-up.

Two case studies will be presented. The case n°1 regards a marble altar located inside the "Certosa di San Martino" in Naples (Italy), characterized by decorations with an organic matrix and by a kaleidoscopic chromatic range. Two different luminous scenarios were set, each obtained by two projectors (CCT of 3000 K and 4000K respectively), in order to guarantee an illuminance level at the altar equal to 300 lx.

The case n°2 regards a copy of "La dame en Bleu" by Matisse, installed in the Photometry and Lighting Laboratory of the Department of Industrial Engineering at the University of Naples Federico II. In this case 12 settings were considered by combining two CCTs (3000K and 4000K), two illuminance levels (50 lx and 300 lx), three backgrounds (white, blue and red).

For each case study, about 20 subjects performed a test, to express their preferences regarding the valorisation of the artworks colours.

## 2. Method

Following subparagraphs describe the two case studies and the method applied to carry out the survey.

Particular attention is given to materials characterization, lighting conditions, choice of luminaires photometry, parameters used to set light scenarios and tests structure. The characteristics of the two experiments slightly diverge because, as it was previously reported, the artwork setting strictly influences design choices.

For example, in the case of the "La dame en Bleu", the contribution of daylight is neglected, in order to consider a museum application without daylight. The opposite applies to the marble altar of the "Certosa di San Martino", located in a chapel of a church, daylit by a window located in the top of the perimetral wall.

Moreover, the marble altar frontal of the "Certosa di San Martino" is surrounded by other elements of high artistic value, consequently LED projectors, useful to define accent lighting, were chosen. For "La Dame en Bleu" LED wall-washers were used being suitable to light paintings.

As for the lighting of the marble altar frontal, CCT is the only variable parameter used to define luminous scenarios. On the contrary, as regards "La dame en Bleu" illuminance levels at the painting and colours of the wall were changed. Two illuminance levels were considered in order to evaluate differences between

maximum levels prescribed by regulations (defined to account for risks of damage due to excessive light exposure) and higher ones. As for the altar frontal, regulations do not impose exposure limits considering that marble is not a light-sensitive material. Moreover because of its positioning in the chapel, it was not possible to vary any other environmental characteristics.

As for the survey, in each case, subjects previously performed and passed the Ishihara Colour Blindness Test, for the assessment of a correct colour vision, and a self-assessment test named Self Assessment Manikin, for the control of mood. However, questions related to the evaluation of the artwork were different. Specifically, in the case n°1 they were exclusively about the perception of the altar colours quality. In the second one, they also referred to the perception of the environment and to the capability of the setting to enhance or not the artwork perception.

For each case-study, in order to characterize chromatic features of the considered artworks, the spectral reflectances of each material were detected thanks to the use of a Konica Minolta CM 2600d spectrophotometer. Then the related chromatic characteristics were derived. Moreover, in order to characterize the luminous environment, CCTs and illuminance levels were measured by Konica Minolta CS 2000 Spectroradiometer and Konica Minolta TC10 Luxmeter respectively.

## 2.1 Case n° 1: the "Certosa di San Martino"

The "Certosa di San Martino" represents an excellence of the Neapolitan baroque art: the church of the Certosa has a single aisle (NW-SE axis) and six chapels adjacent to it, each entirely decorated with marble inlay works and paintings. The research illustrated in this paper focused on the **San Bruno's Chapel**, realized by Cosimo Fanzago (1631-1656), and in more detail on the "*paliotto*", which is the frontal decorative element of the altar.

The aisle of the church is lit by windows located in the top of the walls, whereas the chapels have a single opening above the altar (Figure 1).



Fig. 1 - The aisle of the "Certosa di San Martino" and San Bruno's chapel

All windows are shaded by UV-filtering curtains with a low transmittance factor, so in order to reduce daylight entering. It was decided to not exclude daylight contribution in the experiment, in order to maintain the real lighting condition, thus offering only the possibility of mesopic vision. The experiment was carried out in July from 11 to 12 am. Considering weather conditions specific of this period, the measured daylight contribution ranged from 30 to 60 lx and the maximum value was obtained at noon in a clearly day.

Without electric light, these low daylight levels determine an atmosphere of solemnity and concentration which is typical of holy architectures. On one hand this condition is particularly appropriate to fulfil the worship functions for which it was built, but on the other hand it does not emphasize the unique polychromy of the decorations, for which the church is currently visited, since it became a museum. Even if the original lighting conditions are respected, the goal of this research is to light up in an accurate way the most significant decorative elements, in order to enhance their beauty.

The altar frontal is characterized by six colours and very small chromatic variations are present. Figure 2 reports the marble spectral reflectances and chromatic coordinates.

As the colours circle shows, two colours are located in the first quarter and are characterized by chroma values equal to  $C^*_{red} = 21$  ;  $C^*_{yellow} = 38.6$ . On the contrary, the others are located in the second quarter, but they are characterized by very low chroma values ( $C^*_{green} = 0.39$  ;  $C^*_{grey} = 0.15$ ); for this reason it is difficult to distinguish them.

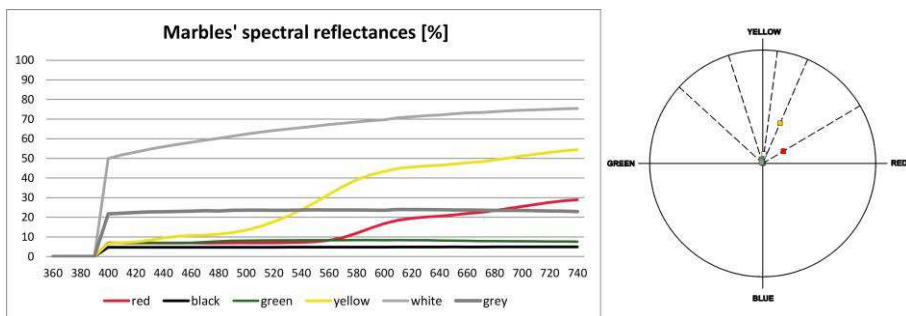

Fig. 2 - The spectral reflectances and chromatic coordinates of the "paliotto" marbles

Four LED projectors, two with CCT equal to about 3000 K and two with CCT equal to about 4000K, with high CRI values were installed, aimed at the "paliotto". The projectors were located at a height from the floor equal to 1.43 m and a distance from "paliotto" equal to 2.50 m, in order to obtain a 300 lx constant illuminance on the altar frontal.

Figure 3 reports the light scenes SPDs and photometry of the selected projectors.

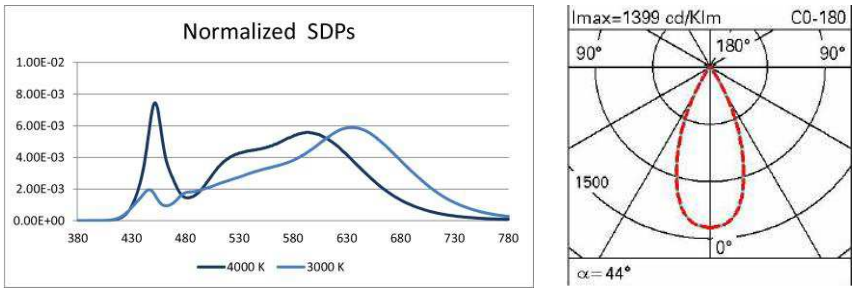

Fig. 3 – Light scenes SPDs and projector photometry.

Table 1 reports the measured luminous scenarios characteristics:

Light scenes	Illuminances [lx]	CCTs [K]	CRI	$\Delta uv$
3000 K	317	2797	97	-0.002
4000 K	320	4199	84	-0.0017

Tab. 1 – Light scenes characteristics

Figure 4 shows the altar frontal lit by the two different light scenarios.



Fig. 4 - The marble altar lit by the two different light sources

For each spectral distribution, 20 subjects (average age 27 years) performed a test in order to evaluate their preferences regarding the valorisation of the “paliotto” colours.

Test consisted of five questions aimed at defining colours perception quality:

Considering the luminous scenario you see, colours are:

- low contrast-high contrast;
- dark - bright;
- unsaturated - very saturated;
- boring - vivid
- unpleasant - pleasant.

Questions were randomly asked and each subject repeated the test twice for each SPD in two different moments. People answered by drawing a cross on a linear and

not graduated diagram (see Figure 5). Only during data processing phase, a graduated scale, ranging from 1 to 10, is added to the diagram, in order to translate graphic answers in numeric values.

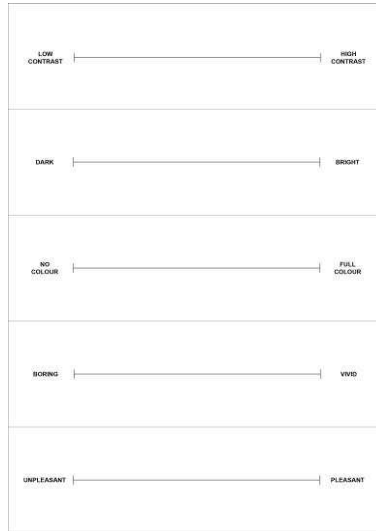

Fig. 5 - Example of test

## 2.2 Case n° 2: “La Dame en Bleu”

The second case study regarded a simulation of a museum application, set up at the Photometry and Lighting Laboratory of the Department of Industrial Engineering at the University of Naples Federico II. The selected painting was a reproduction of “La Dame en Bleu” by Matisse (1937), a stylised portrait of a woman, characterised by wide and well defined chromatic areas (Figure 6). Chromatic range consisted of seven colours: this made easy the chromatic and perceptive analysis.

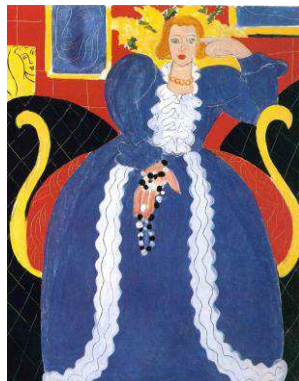

Fig. 6 – “La Dame en bleu”, Matisse, 1937

The laboratory is a neutral room in which daylight contribution was excluded obstructing the window thanks to an opaque panel. The painting was lit by two LED wall-washers, in order to obtain a good illuminance uniformity at the painting surface. Luminaires were managed by a DALI controller; through a touch panel four luminous scenarios were set, varying CCT (3000 K and 4000 K) and illuminance level (50 lx and 300 lx). Figure 7 shows the light scenes SPDs and the wall-washers photometry.

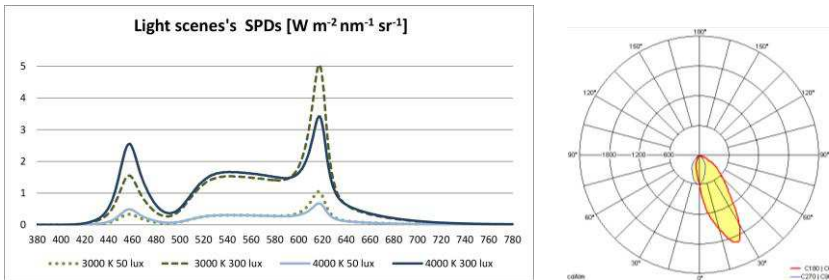

Fig. 7 – Light scenes SPDs and wall-washer photometry

The measured luminous scenarios characteristics are reported in table 2.

Light scenes	Illuminances [lx]	CCTs [K]	CRI	$\Delta uv$
3000 K	61	3005	91	-0.0042
3000 K	308	3013	91	-0.0029
4000 K	57	4004	90	-0.0045
4000 K	299	4071	88	-0.0024

Tab. 2 – Light scenes characteristics

The wall to which the painting was installed, was alternatively covered by blue, red and white cardboards. These specific backgrounds were chosen after analysing the most recurring museum settings. Figure 8 shows spectral reflectances of painting and background colours and the chromatic coordinates of the painting colours. As the colours circle shows, three colours are located in the first quarter and are characterized by following chroma values:  $C^*_{red} = 21$  -  $C^*_{orange} = 65$  -  $C^*_{pink} = 20$ ; only one colour was located in the second quarter and was characterized by a chroma value equal to  $C^*_{yellow} = 91$ ; one colour was located in the fourth quarter and was characterized by a  $C^*_{blue} = 68$  chroma value.

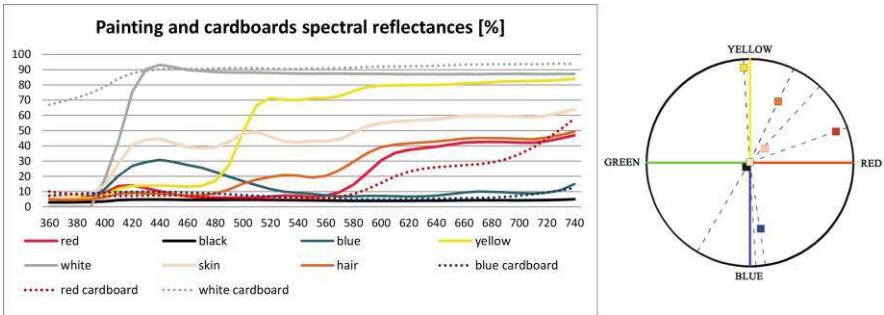

Fig. 8 – Painting and cardboards spectral reflectances and chromatic coordinates of the painting colours

The painting (66 cm x 53 cm) was hung up at a height from the floor equal to 1.97 m and, during the survey, subjects stood up at distance of 1.35 m, in order to guarantee a  $28^\circ$  visual angle (Figure 9).

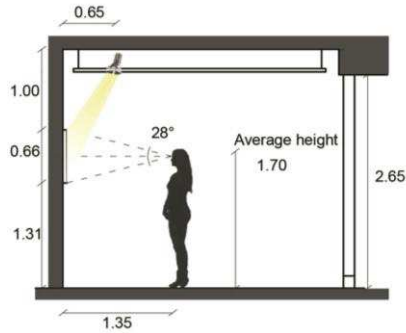

Fig. 9 – Test room's measured section

The 21 selected subjects were 25 years old on average and were architects or students. Each of them performed the test twice for each scenario and each background during different days, i.e. each person was interviewed 42 different times.

The test consisted in a questionnaire about painting colours perception, pleasantness of setting and visual comfort. As for colours and painting perception, two couples of opposite attributes were chosen: low contrast/high contrast - unsaturated/very saturated and dark/bright - unpleasant/pleasant.

As for pleasantness of exhibition set-up, three couples of attributes were chosen: uncomfortable/comfortable - tense/relaxed - diminished/enhanced. Each couple corresponded to the limit values of an evaluation scale that goes from -3 to +3, with a neutral value of 0 [11]. Figure 10 shows an example of test. In order to guarantee the perfect subject's adaptation to the luminous scenario, the questions were read by an external reader, while the interviewee was only focused on the painting setting. Among two consecutive light scenes, a minute of dark and then a minute to adapt to the new scenario were scheduled.



In the following, the questions reported in Figure 10 will be indicated as Q1,Q2,....,Q7.

Background color \_\_\_\_\_ Light scene \_\_\_\_\_ Name \_\_\_\_\_ Date \_\_\_\_\_

**COLORS**

1) The colors of the painting show

low contrast |-----| high contrast

-3   -2   -1   0   1   2   3

2) The colors of the painting appear

unsaturated |-----| very saturated

-3   -2   -1   0   1   2   3

**PAINTING**

3) The painting appears

dark |-----| bright

-3   -2   -1   0   1   2   3

4) This lighting condition is

unpleasant |-----| pleasant

-3   -2   -1   0   1   2   3

**EXHIBITION SET-UP**

5) The visual perception of this exhibition set-up is

uncomfortable |-----| comfortable

-3   -2   -1   0   1   2   3

6) The atmosphere of this exhibition set-up is

tense |-----| relaxed

-3   -2   -1   0   1   2   3

7) The painting's perception in this exhibition set-up is

diminished |-----| enhanced

-3   -2   -1   0   1   2   3

Fig. 10 – Test example

### 3. Results

#### 3.1 Case n°1 : “Certosa di San Martino”

Regarding the first case, the goal of the test was to evaluate how the different CCTs affect the perception of the “paliotto” colours. Data obtained by the test indicated a clear tendency by the interviewees to prefer the light scene with a 3000 K CCT, as showed in figure 11.

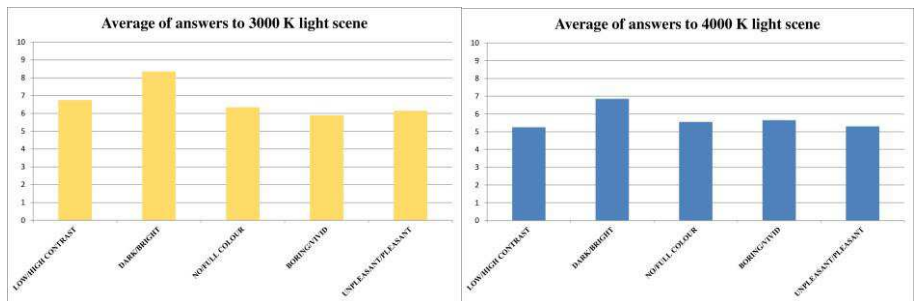

Fig. 11 – Comparison of test results for the two different light scenes

More specifically, for equal illuminance level, the light scene with a 3000 K CCT was considered brighter than the 4000 K CCT one, and the “paliotto” colours were perceived highly contrasted and saturated. Moreover, for both light scenes, the colours were considered vivid on average.

### 3.2 Case n°2: “La Dame en Bleu”.

Results obtained by data processing showed how CCT, illuminance level and background colour affect the two-dimensional artwork perception and pleasantness of exhibition set-up.

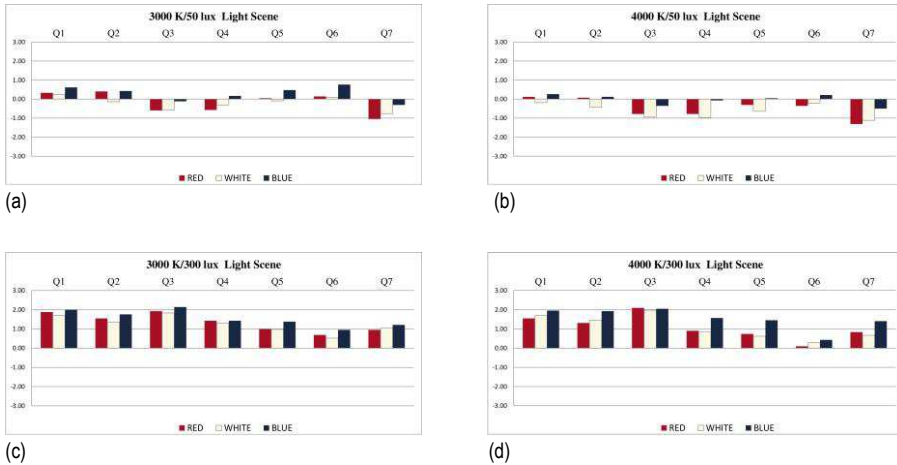

Fig. 12 (a,b,c,d)– Test results for four different CCTs and illuminance levels combinations

Figure 12(a,b,c,d) shows the questionnaire results for all analysed luminous scenarios.

Colour perception was evaluated by means of Q1 and Q2 and the most influencing factor is illuminance level: for each CCT and background, colours were perceived well contrasted and saturated, for an illuminance level equal to about 300 lx. On the contrary, for a 50 lx illuminance level, results were clearly worse, especially for white background.

Q3 and Q4 evaluate the painting perception and illuminance level was again the most influencing parameter. Indeed, for each combination of colour background and CCT, the 50 lx illuminance level showed worse results, with negative values as regards red and white backgrounds.

The perception of the exhibition set-up was considered rather comfortable for each CCT and high illuminance level and interviewees considered the blue background as the most comfortable. On the other hand, for the low illuminance level, red and blue backgrounds were evaluated as neutral, whereas the white one was generally considered uncomfortable. As for Q6, the most influencing parameter was CCT: with a 3000 K CCT the setting was perceived as relaxing for each combination of illuminance level and colour background, with a slight preference for the blue one.

On average, for high illuminance levels, the painting perception was considered enhanced and the combination of 4000 K CCT and blue background turned out to be the most favourite one; low illuminance level diminished the painting perception, especially for red and white backgrounds and for a 4000 K CCT.

## 5. Conclusions

The two case studies were relative to different kinds of two-dimensional artwork, therefore parameters used to evaluate the results and the test were considerably different.

Indeed, in the first case, concerned a marble artwork, CCT was the only variable parameter considered, because marble can afford high illuminance levels with no risk of damage. As it was expected, the preferred light scene was the 3000 K CCT one, since the “paliotto” colours were mainly in the red-yellow range and such CCT enhances the perception of this kind of colours.

On the other hand, the second case consisted in an artwork sensible to high illuminance level, which can be harmful for the surface integrity [2]. Moreover, the exhibition set-up plays a fundamental role in the painting perception. For this reason, more parameters came into play, increasing the complexity of the analysis. Overall, results showed that the preferred setting was blue background with 4000 K CCT and 300 lx illuminance level. Red and white backgrounds had comparable results for high illuminance levels and negative marks were registered for low ones.

CCT variations slightly affected the results, whereas illuminance level was the most affecting parameter to perception of the colours and of the painting. Marks heavily improve with a high illuminance level, for each colours background. However there are constrictions to the illuminance level, as imposed by European Standard EN 16163-2014 [12], that sets the maximum values allowed of illuminance level and Annual Light Exposure, in order to preserve artworks. Standards do not permit the continuative exposure to 300 lx illuminance level; this issue can be solved by means of occupancy sensors, that increase the illuminance level only when needed.

Test results are relative to the two cases and cannot be considered valid for all kinds of artwork; indeed further experiments are needed, changing exhibition set-ups and two dimensional artwork typologies. These case studies could help designers that approach to the light project to choose the luminous scenarios aimed at the valorisation of cultural heritage.

## References

- [1] Bellia, L., Pedace, A. & Stefanizzi, E., 2014. *Perceived and measured colour attributes under different sources*. Como, Italy, Proceedings of the 14th International Symposium on the Science and Technology of Lighting (LS14).
- [2] CIE 157, 2004. Control of damage to museum objects by optical radiation.
- [3] Davis, W. & Ohno, Y., 2010. Color quality scale. *Optical Engineering*, 49(3).
- [4] Fotios, S. A., 1997. *The perception of light sources of different colour properties*,. United Kingdom: Doctor of Philosophy Thesis, UMIST.
- [5] Houser, K. W. & Gibbons, R. B., 1999. Composite CRI. *Journal of Illuminating Engineering Society* , 28(1), pp. 117-129.
- [6] Rea, M. S. & Freyssinier, J. P., 2010. Color rendering: beyond pride and prejudice. *Color Research and Application*, 35(6), pp. 401-409.
- [7] Schanda, J., Csuti, P. & Szabò, F., 2014. Colour fidelity for picture gallery Part 1: Determining the optimum light-emitting diode spectrum. *Lighting Research and Technology*, Issue 0, pp. 1-10.
- [8] Smet, K. A. G. et al., 2012. A memory colour quality metric for white light sources. *Energy & Buildings*, Volume 49, pp. 216-225.
- [9] Smet, K. et al., 2011. Correlation between color quality metric predictions and visual appreciation of light sources. *Optical Express* , 19(9), pp. 8151-8166.
- [10] TC1-91, C., n.d. *New methods for Evaluating the Colour Quality of White-Light Sources*, s.l.: s.n.
- [11] Zhai, Q. Y., Luo, M. R. & Liu, X. Y., 2014. The impact of illuminance and colour temperature on viewing fine art paintings under LED lighting. *Lighting Research and Technology*, Issue 0, pp. 1-15.
- [12] EN 16163, 2014. Conservation of Cultural Heritage - Guidelines and procedures for choosing appropriate lighting for indoor exhibitions.

# The Impact of Color on Increasing Self-Confidence among People with Multiple Sclerosis Disease

<sup>1</sup>Bahareh Abdollahi Gohar, <sup>2</sup>Maryam Khalili

<sup>1</sup>MA Student, Departement of Industrial Design, Pardis Alborz, University of Tehran, b.abdollahi2013@yahoo.com

<sup>2</sup>Departement of Industrial Design, University of Tehran, maryamkhalili@ut.ac.ir

## 1. Introduction

Multiple sclerosis or MS is a disease of the immune system that affects the central nervous system [1]. The cause of this disease is not clear but it seems that the activation of immune mechanisms against the antigen is one the causes [2]. The first protests of the disease is appeared between the ages of 20 to 40 years old with the symptoms such as anxiety, weakness, imbalance, vision impairment, mental changes such as depression, frustration and loss of the ability to solve the problems [3].

More than 400 thousand people in North America and 500 thousand people in Europe and a total of 2.5 million people around the world are infected by MS [4].

In Iran, the prevalence of MS is about 15-30 in 100. According to experts in MS Society of Iran, each year 5000 new patients are added on the list of the center [5].

This disease threatens the independence and the ability of person to participate effectively in family and community. It leads the patients to the lack of competence and self-confidence [6]. It often happens at the time that a person expectes and health and because of its unpredictable nature, some patients may feel that they are not able to plan for their future [7].

This disease would interfere with seeing, walking, moving multiple organs and generally leads to multiple paralysis. Its symptoms in different people are different and that is one of the biggest problem of patients regarding to treatment strategies and measures. The first signs include fatigue, weakness, numbness, loss of balance and difficulty with coordination [8].

Vision disorders are the most common symptoms of MS. These disorders can be assisted with the loss of vision, color vision impairment and visual field defects [9].

About two-thirds of MS patients have the intestinal problems [10]. psychological disorders are also the common symptoms, although they are not directly associated with MS symptoms. 50-60% of patients have the depression problems. Suicide is a common complication in these patients [11]. Cognitive dysfunction includes memory impairment, attention disorders, difficulty in solving problems, and data analysis problems in shifting attention [12].

About 70% of MS patients are experiencing the loss of selfconfidence and in many cases they have an important emotional problems [13].

For better walking, MS patients need some mobility assistances like canes but in society they tempt to cover their disease by not using such assistance. By using colors in assistances like canes, the patient's confidence will increase and in consequence they prefer to use cane more often. So this paper presents a new approach for using colors and patterns in these patients' canes.

This research is a descriptive study. A number of 200 patients from Iran MS Society were chosen, which were in condition to participate in the study. The sampling

method was simple and available. Questionnaire and interview were used for gathering data and then the data were analyzed by descriptive statistics. The statistics then showed that 78% of MS patients need to use canes and they don't use them because they don't appreciate the look. These canes are not used by these patients so it can bring them lots of consequences causes difficulties for them.

The outcome of the present research indicates that by using colorful and patterned canes 59% of patients got interested in using them and more than 67% of the patients showed tendency towards canes with colors. These outcomes indicate that colors have strong effects on patients and by using colors patient's self-confidence and social spirit will increase.

## **2. Self-Confidence**

We have a basic need in life that is "good feeling" about ourselves. We need to esteem ourselves with a good physical, intellectual, emotional and human feeling. Self-confidence feeling is full of emotion and is based on the values that are attached to the society [14].

Self-confidence influences the quality in all stages of life and plays an important role in people's behavior. One of the most common psychological disorders, is the loss of self-confidence because of some diseases [15].

Self-confidence has an important effect on the positive approach in psychological treatment and introduce to the mental health [16]. Low self-confidence can cause numerous problems including social conflicts, a variety of psychiatric disorders, especially depression, suicide, anxiety and addiction [17]. Other studies have shown that reducing self-confidence is also one of the reasons for compatibility problems [18] and is one of the risk factors for suicide attempt [19].

Other studies show the impact of high self-confidence in order to improve clearly the performance at any age, employment and social level as well as organic and inorganic disease [20].

In this regard, a literature review of MS patients shows a high degree of stress of quality of life, difficulties in social role and relationships, depression, anxiety and poor sleep quality [21].

Depression is the most common psychiatric disorder in MS patients and its prevalence is about 27-54% [22]. The recent studies report the prevalence of 37% of anxiety disorders in these patients [23]. Moreover, 3 % of people with MS, said that the anxiety symptoms are the most disabling factor in the first year after diagnosis report [24]. The prevalence of anxiety in women is two times more than men [25].

## **2. Cane**

Cane in definition is something that can be took in hand on which someone can lean to walk [26]. The patients can use the cane to have more stability in walking. Using cane affects positively the breast muscles and reduces the pressure on the knees [27]. There are different types of cane such as : blind cane, elderly cane, handicap cane, sport cane, and decorative cane. Depending to the expected performance of cane there are different categories that we describe them:

- Regular cane or 'C cane' is for someone who has the pain or weakness in one or two feet or has the trouble to maintaining his/her balance. Using this

cane reduces the weight on legs. For people who have the balance problems, especially elderly people, using these devices can prevent serious consequences such as fractures and prolonged hospitalization and even prevent death.

- Curved cane is another device which can devide the weight of patient in the line of cane. Curved cane is suitable for patients who have the difficulty in walking because of their pain in knees or hip.
- Four legs cane has a greater lean surface and can support more weight. This device can stand on the ground if the patient wants to use his/her hands.
- Axillary canes are suitable for the personnes who need the force of their arms to balance their walking. An axillary cane support 80% of the weight of a person and two axillary canes support 100% of the weight. These canes need more energy and powerful arms, so they are not so good for elderly people [28].

### **3. Color and Psychology**

Color is the most important visual element which is full of feeling. Many theorists believe that colors affect the human psyche. Because of the importance of the psychological impact of color on our environment, today it has become an applied science [29].

Knowing the language of colors, can help designers in their product design to consider the advantage of the psychological impact of color on consumer behavior. The color effects are not the same for all people but we can not ignore the power of colors [30]. Human is able to detect more than 7 milion colors and it is the largest area of human experiences [31].

As color evokes emotion, thinking, living and culture of a community, many people mutually can also be psychologically influenced by color [32].

Colors affect the human spirit, and also the human body [33]. Color is a visual element which creates the emotions, but it is also able to transmit the message [34]. Itten said that colors are the forces that consciously or unconsciously and pisitively or negatively affect our thought [35].

There are lots of tests to choose the colors according to the personality of people or depending to the expected color effects [36].

An individual's response to color can be based on some characteristics such as age, sex, ethnicity or socio-economic groups and even local weather [37]. So it is difficult to find the real results about colors even the colors are associated with psychological and symbilic dimensions [38].

### **4. Methodology**

More than 60% of MS patients suffer from muscle weakness especially on the legs and need the mobility aids such as canes to walk. Many MS patients do not use the mobility aids because they want to hide their MS symptoms, while these equipements can help them to stop the growth of disease [39].

Since low self-confidence is one of the depression symptoms, and regard to the large number of MS patients who are suffering from low self-confidence, the present

study was done to evaluate the confidence of patients before and after using colored canes and the effect of color on mobility aids to increase the self-confidence.

This study is conducted in MS Society of Iran in Tehran in 2015-16 with the participation of 200 MS patients (including 105 females and 95 males) between 27-42 years old. Having low balance disorders was necessary for patients who participated in this study. Some clinical factors are also indicated for this study such as they have not yet reached to the acute phase of their illness and can walk without the other's help. At the end of the interview and questionnaire the principle and secondary needs of patients are provided as shown in Tab. 1. MS patients indicated that the existing canes are not beautiful and they use them because they do not any other choice.

<b>Principle needs</b>	<b>Secondary needs</b>
Folding and adjustable height	Patient's balancing
Multi-functional	Proper hand grip
Reusable after its life cycle	Lightweight
Warning the disease symptoms	Beautiful
cheap	Distinguished
	Creating the sense of pride
	Create the sense of self-confidence

Tab. 1 – The principle and secondary needs of MS patients

The results showed that MS patients have low self-confidence by using their existing canes. They said that using these canes affects their image in the society and the others know their disease, this is what the majority of MS patients escape from that. So it seems that in addition to increase the performance of existing canes, colors can be also the most important factor to satisfy these people. In Tab.2 the canes properties indicated by MS patients and translated as design parameters are illustrated.

<b>Needs</b>	<b>Importance</b>	<b>Index</b>
Balancing	*****	Sectional area must be at least 6 inches
Full body stability	*****	Basic cane must have at least 3 branches
Proper hand grip	***	Handle diameter must be between 2.5-5 cm and the angle of connection must be approximately 90°
Lightweight	**	Maximum weight 1 kg
Distnguished	*****	New form and color
Beautiful	*****	Good performance with vivid colors
Pride sense	*****	Different from the patients' cane
Self-confidence sense	*****	Beautiful color and good design
cheap	**	According to the patient's purchasing power

Tab. 2 – Translation the needs of MS patients to design index



In this step, to identify the design factors, some of the existing canes in Iran were analysed (Fig. 2). The results are shown in Tab.3. According to the obtained results, the cane (C) is more performant and responds better to the needs of users.

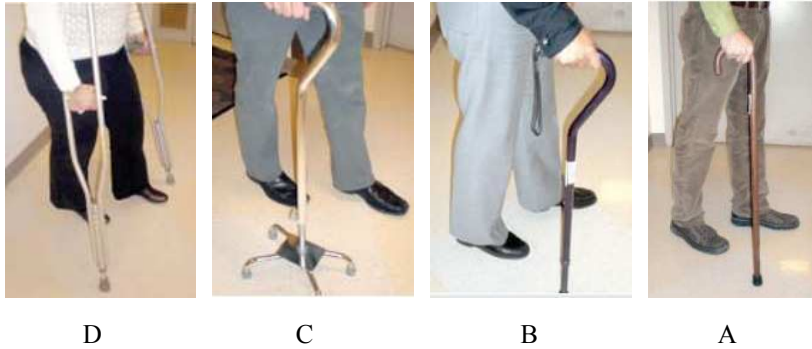

Fig. 1 – Four types of existing canes for MS patients.

Auxiliary cane <b>D</b>	Four leg cane <b>C</b>	Curved cane <b>B</b>	Standard cane <b>A</b>	Importance	Needs
**	****	***	**	5	Balancing
***	****	**	**	5	Eviting the shoot
**	***	**	*	4	Hanf grip
**	*	*	**	4	Lightwei ght
*	*	*	*	3	Portable
*	**	**	*	3	Height adjustable
0	0	0	0	3	Folding
0	0	0	0	5	Beautiful
0	0	0	0	5	Pride sense
*	*	*	*	2	Cheap
*	*	*	*	4	Desirable

Tab. 3 – The comparison of four types of existing canes and their characteristics.

According to the studies, the self-confidence has seven indicators such as :

- Introversion/Extraversion
- Compromise
- Personal satisfaction
- Ability to empathize
- Emotional evolution
- Verbal skills
- Defuse the tension [40]

The participants are asked about the most important self-confidence indicators using the canes. The results are shown in Fig. 2.

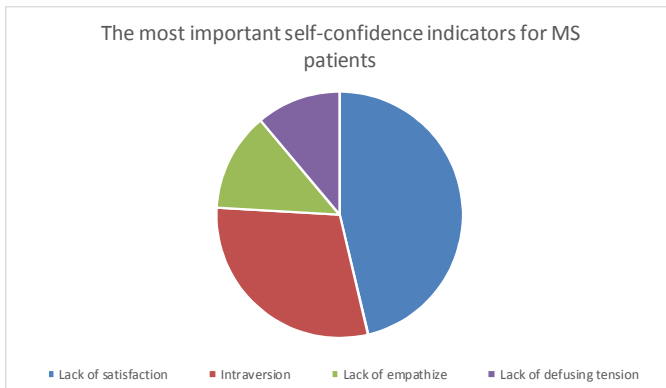
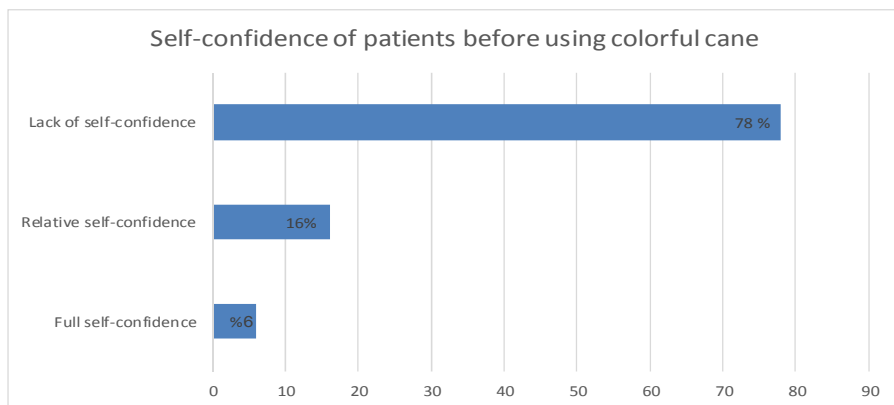
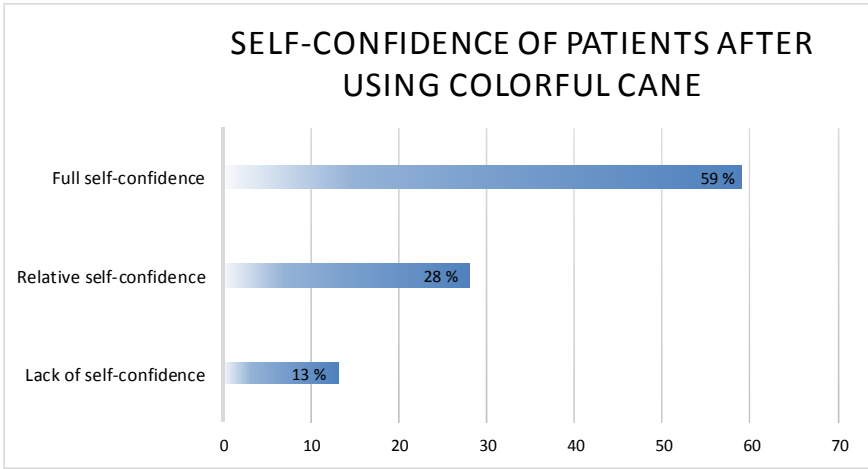

Fig. 2 – The most important self-confidence indicators for MS patients.

In the second survey, a self-confidence test is done using 30 questions. Each patient use two types of cane during one week. The results are shown in Tab. 4.



Tab. 4 – Self-confidence patients before using colorful cane.



Tab. 5 – Self-confidence patients after using colorful cane.

## 5. Result

According to the proposed indicators, a colorful cane is designed and is tested by MS patients. In this study, in order to measure the variables of two standardized questionnaires, we have integrated the design process in the same direction and its results are directly applied to the survey.



Fig. 3 – The colorful canes designed for MS patients.

## 6. Conclusion

The aim of this study was to evaluate the effectiveness of the use of a cane with a new color to improve the self-confidence of MS patients and to reduce their anxiety respectively. Due to this aim, a group of patients were studied using questionnaires in two pre-test and post-test phases.

The use of colorful canes indicated a higher level of confidence and reduces the depression and anxiety in MS patients. So it can be concluded that the use of a cane with a new color can improve the self-confidence of MS patients and play a significant role in their social image.

## Bibliography

- [1] Kasper D., Braunwald E., Fauci A., Houser S., Longo D., Jameson J., "Harrison's principles of Internal Medicine", Volume 2, 16th edition, New York, Mc Grow- Hill Co, 2005; p: 2461.
- [2] Smeltzer S., Bare B., Hinkle J., Cheever K., "Text book of Medical Surgical Nursing", Volume 2, 12th edition, Philadelphia, Lippincott, Williams and Wilkins Co, 2010, p1956.
- [3] Murgante L., "Hope in Multiple Sclerosis, a nursing perspective", Int J MS Care. 2000; 2(2): P:3.
- [4] Masoodi R., "Effect of self care program on quality of life patients with Multiple Sclerosis", Health Education MSc Thesis, University of Tarbiat Modarres. 2006; p: 5 (In Persian)
- [5] Iranian MS Society, Familiarity with Multiple Sclerosis, 2006; Vol 1. p: 22 (In Persian)
- [6] Lotfi J., "Abstract book of 3th International Iranian Congress on Multiple Sclerosis", 2004; p: 23 (In Persian)
- [7] Brunner & Suddarth's., "Text book of Medical – Surgical Nursing". Puran Semi translation. Tehran:Nashr & Boshra collaboration with Tohfe, 1384; p: 189. (In Persian)
- [8] Etemadi far M, Chit saz A, "multiple sclerosis", M.S. Isfahan: Mashal Publications, 1384; p:13. (In Persian)
- [9] Harrison. "Nerves Harrison 2005". Seyed Mostafa Emami Meibodi translated. Tehran: Cheraghe Danesh Publications collaboration with Shabname Danesh, 1384; p:341.
- [10] Lewis R., Merritt,s , "Neurology". 11th edition. Philadelphia: Lippincott, Williams & Wilkins Co, 2005; p:950.
- [11] Jafarian N., Sadeghi A., " Multiple Sclerosis and cares". Tehran: salami and jamee negar, 1385; p88. (In Persian)
- [12] Rashvand F., "Study training needs in M.S patients and provide appropriate training model for M.S patients in 1386", MSc Thesis, Eslamic Azad University, 1386; p:45. (In Persian)
- [13] Goodin D S & the Northern California MS Study Group. Survey of multiple sclerosis in Northern California. From: <http://www.stockton-press.co.uk/ms>, 1999; p: 78-88.
- [14] 3-Weiten W, Lloyd M. "Psychology applied to modern life". 5th ed. Publishing company, 1996: 142-7.
- [15] Capaldi D.M., Stoolmiller M. "Co- occurrence of conduct problems and depressive symptoms in early adolescent boys": Prediction to youngadult adjustment. Dev Psychopathol. 1999 Winter; 11(1): 59-84.
- [16] EslamiNasab A., "Psychology of Self confidence".Tehran:Mehrdad,1373, P:80. (In Persian)
- [17] Beautrais AL, Joyce PR, Mulder RT. « Personality traits and cognitive styles as risk factors for serious suicide attempts among young people. Suicide Life Threat Behav.» 1999 Spring; 29(1): 37-47
- [18] Mutran EJ., Reitzes DJ., Bratton KA, Fernandez ME." Self-esteem and subjective" Fernandez ME. Self-esteem and subjective Fernandez ME. Self-esteem and subjectivesimilarities and differences Gerontol Psychol Sci Soc Sci. 1997 Mar; 52 by gender. J(2): S 89-96.
- [19] Macaskill GT., Hopper JL., White V, Hill DJ. "Genetic and Environment Variation in Eysenck Personality Questionnaire scales measured on Australian adolescent twins. Behav Genet". 1994 Nov; 24(6): 481-91.
- [20] Ames PC., Riggio RE., "Use of the Rotter Incomplete Sentences Blank with adolescent populations": implications for determining.
- [21] Neinavai ZH., "Self confidence Road to happiness".Tehran:Nedaye farhang,1375, P:11. (In Persian)

- [22] Korostil M., Feinstein A., "Anxiety disorders and their clinical correlates in multiple sclerosis patients". *J Mult Scler* 2007; 13: 67-72.
- [23] Stenager E., Knudsen L, Jensen K., "Multiple sclerosis: correlation of anxiety, physical impairment and cognitive dysfunction". *Ital J Neurol Sci* 1994; 15: 97-101.
- [24] Malcomson KS., Dunwoody I, Low- Strong AS. "Psychological intervention in people with multiple sclerosis". *J Neurol* 2007; 254: 1-13.
- [25] Siegert RJ., Abernethy DA. "Depression in multiple sclerosis: a review". *J Neurol Neurosurg Psychiatry* 2005;76:469-75.
- [26] <https://en.wikipedia.org>
- [27] JS Ju, E Ko, EY Kim - Proceedings of the 11th international ACM, 2009
- [28] [www.tebyan.net](http://www.tebyan.net)
- [29] Itten J., "The art of color". Translate to Persian by: Sherve AA. Tehran:Yesavoli;1999.(Persian).
- [30] Atkinson RL, Atkinson RC. Hilgard's Introduction to Psychology. International Thomson Publishing; 1999.
- [31] Norman R, Scott W., " Color and affect are view and semantic evaluation". *J Gen Psychol* 1952; 46:185-223.
- [32] Simon WF., "Number and color responses of some college students: preliminary evidence for a blue and seven phenomenon". *Percept Mot Skills* 1971; 33:373-374.
- [33] De Grandis, Luigina (1986), "Theory and Use Of Color", John Gilbert, Prentice Hall, New Jersey.
- [34] Volan P, "Juxtaposition of colors". Translate to Persian by: Deheshti F. Tehran: Karang, 2010. (Persian).
- [35] Itten J., "The art of color". Translate to Persian by: Sherve AA. Tehran: Yesavoli;1999.(Persian).
- [36] Moudi M., "The use of color in ergonomics". Tehran: Hesebartar, 1375, P:15. (In Persian)
- [37] Goethe J,W., "Theory of Colors", Massachusetts, MIT Press, Cambridge, 1982.
- [38] Whiles P., "Colors and therapeutic effects. Translate to Persian by: Azami M. Tehran: Sooratgar, 2011. (In Persian)
- [39] Ayan Perez C., Martin Sanchez V., De Souza Teixeira F., De Paz Fernandez JA., "Effect of a resistance training program in multiple sclerosis". *Mult Scler* 2007;14(1):35-53.
- [40] Asikainen TM., Kukkonen-Harjula K, Miilunpalo S., "Exercise for health for early postmenopausal woman: A systematic review of randomised controlled trials." *Sports Med* 2004;34(11):753-78.



# From artistic expression to scientific analysis of color texture

<sup>2</sup>Alexandre Bony, <sup>1</sup>Larissa Noury, <sup>2</sup>Christine Fernandez-Maloigne

<sup>1</sup>CEC ("Couleur - Espace - Culture"), Paris, France. <http://www.larinoury.fr/index.php/fr/> [larinoury@gmail.com](mailto:larinoury@gmail.com)

<sup>2</sup>University of Poitiers, XLIM Laboratory, 11 Bd Marie et Pierre Curie, BP30179, 86962 FUTUROSCOPE cedex, France. [Alexandre.bony@univ-poitiers.fr](mailto:Alexandre.bony@univ-poitiers.fr) - [christine.fernandez@univ-poitiers.fr](mailto:christine.fernandez@univ-poitiers.fr)

## 1. Introduction

Image classification is one of the most important tasks in image analysis and computer vision since 1980s [1, 2, 3, 4], helpful for numerous applications, including pattern recognition and object tracking [5, 6, 7], skin detection and face tracking [8, 9], image retrieval [10, 11], defect detection and metrology [12, 13], biomedical and satellite or aerial imagery [14, 15, 16]. Color and texture provides important cues for all these applications but it's often difficult to combine these two main information. So, in this paper we present a new formulation for color Run-Length Matrices (cRLM) that we apply to the classification of different styles of painting. This study is part of a regional research project about digital patrimony. To begin, we explain our methodology to compute cRLM and the associated attributes. Finally we describe the promising results obtained on a database of 6 paintings of 4 different artists before the conclusion.

## 2. Stat of the art for color texture classification

Texture and colour are important image properties for classification that have received significant interest from research community, with prior research generally focusing on examining separately colour and texture features. A major problem is that textures in the real world are often not uniform, due to changes in orientation, scale or other visual appearance. In addition, the degree of computational complexity of many of the proposed texture measures is very high. So the main problem in color texture characterization and classification is to define the real characteristic parameters. In this part we will describe the main existing approaches for texture, color and color-texture analysis.

### 2.1. Texture aalysis

Texture hasn't a formal definition, it can be regarded as a function of the variation of pixel intensities which form repeated patterns [17, 18]. This fundamental image property has been the subject of significant research and is generally divided into four major categories: statistical, structural, model-based, and signal-based methods [19] as we can see on Table 1 from [20].

Table 1 : classification of texture analysis approaches

Category	Method
<b>Statistical</b>	<ol style="list-style-type: none"> <li>1. Histogram properties</li> <li>2. Co-occurrence matrix</li> <li>3. Local binary pattern</li> <li>4. Other gray level statistics</li> <li>5. Autocorrelation</li> <li>6. Registration-based</li> </ol>
<b>Structural</b>	<ol style="list-style-type: none"> <li>1. Primitive measurement</li> <li>2. Edge Features</li> <li>3. Skeleton representation</li> <li>4. Morphological operations</li> </ol>
<b>Filter Based</b>	<ol style="list-style-type: none"> <li>1. Spatial domain filtering</li> <li>2. Frequency domain analysis</li> <li>3. Joint spatial/spatial-frequency</li> </ol>
<b>Model Based</b>	<ol style="list-style-type: none"> <li>1. Fractal models</li> <li>2. Random field model</li> <li>3. Texem model</li> </ol>

Statistical measures analyze the spatial distribution of the pixels using features extracted from first and second order histograms. Two of the most investigated statistical methods are the gray-level differences [21] and the co occurrence matrices [22], sometimes combined [23]. The co-occurrence matrices and their associated parameters are very popular [24, 25, 26, 27, 28, 29]. Another usual approach is the Local Binary Patterns (LBP) concept developed by Ojala et al [30], that attempts to decompose the texture into small texture units and the texture features are defined by the distribution (histogram) of the LBP values calculated for each pixel in the region under analysis. These LBP distributions are powerful texture descriptors since they can be used to discriminate textures in the input image independently of their size. The dissimilarity between two or more textures can be determined by using a histogram intersection metric. An LBP texture unit is represented in a 3x3 neighborhood which generates 28 possible standard texture units. In this regard, the LBP texture unit is obtained by applying a simple threshold operation with respect to the central pixel of the 3x3 neighborhood. On another side, Galloway proposed the use of a run-length matrix for texture features extraction [31]. Various texture features can then be derived from this run-length matrix as we will explain in next part. The Model-based approaches include morphological image processing [32]. These methods are well adapted for macroscopic textures in which primitives and rules of geometrical arrangement are identifiable. Signal processing methods have been investigated more recently. With these techniques, the image is typically filtered with a bank of filters of differing scales and orientations in order to capture the frequency changes [33, 34, 35, 36, 37, 38]. First signal processing methods tried to analyse the image texture in the Fourier domain, but these approaches were clearly outperformed by techniques that analyse the texture using multi-channel narrow band Gabor filters. This approach was firstly introduced by Bovik et al [34] when they used quadrature Gabor filters to segment images defined by oriented textures. This approach was further advanced by Randen and Husoy [38] while noting that image filtering with a bank of Gabor filters or filters derived from a wavelet transform [39, 40] is computationally demanding.



In their paper they propose the methodology to compute optimized filters for texture discrimination and examine the performance of these filters with respect to algorithmic complexity/feature separation on a number of test images. In the family of model-based methods, we can find the fractal description and the random field models. During the past years, several authors discussed to use multiresolution stochastic approaches to model textures [41]. Stochastic models consider textures as samples from a probability distribution on the image space. In this way, each pixel location is considered as a random variable. A parametric probabilistic model is then applied to this random field to obtain the joint or conditional probability distributions.

## **2.2. Color Analysis**

Color is another important characteristic of digital images which has naturally received interest from the research community. This is motivated by advances in imaging and processing technologies and the proliferation of color cameras. Color has been used in the development of numerous classification algorithms that have been applied to many applications [42, 43, 44].

## **2.3. Color-Texture Analysis**

Generally, authors proposed the use of a combination of color and texture features [45]. Texture features are computed in greyscale and combined with color histograms and moments [46, 47]. These combined features are then sent to a classifier for color-texture classification [48]. Other authors proposed the use of color quantization to reduce the number of colors and process the resulting image as greyscale for texture extraction [49, 50]. But the development of advanced unified color-texture descriptors may provide improved discrimination over viewing texture and color features independently. How best to combine these features in a color-texture mathematical descriptor is still an open issue, with strong links with the human perception modeling. To address this problem a number of researchers augmented the textural features with statistical chrominance features [51, 52]. The extra computational cost required by the calculation of color features is negligible when compared with the computational overhead associated. In the family of statistical approaches several authors have proposed color-cooccurrence matrices definitions [53, 54, 55]. Algorithms for color LBP have also been developed [56, 57, 58, 59]. Building on this, the paper by Pietikainen et al [60]. evaluates the performance of a joint color Local Binary Patterns (LBP) operator against the performance of the 3D histograms calculated in the Ohta color space. They conclude that the color information sampled by the proposed 3D histograms is more powerful than the texture information sampled by the joint LBP distribution. This approach has been further advanced by Liapis and Tziritas [61] where they developed a color-texture approach used for image retrieval using both statistical and

signal approaches. In their implementation they extracted the texture features using the Discrete Wavelet Frames analysis while the color feature were extracted using 2D histograms calculated from chromaticity components of the images converted in the CIE Lab color space. Structural approaches using Morphological operators are also extended to color by numerous authors [62, 63, 64, 65]. Others researchers focused on color Model-based approaches using Markovian [66] or color fractal models [67].

### **3. Proposed approach based on RL Matrices**

#### **3.1. Original gray level approach**

Introduced by Galloway [31], Run-Length Matrices have been defined to extract statistical features on the gray level distribution in image. A run is a set of collinear pixels with the same gray level in a given direction and the run length is the number of pixels in a run. The Run-Length Matrix  $M_{\Theta}(n,l)$  contains the number of runs of length  $l$  for each gray level  $n$  for the direction  $\Theta$ . Generally, four directions are used: horizontal, vertical and two diagonals ( $\Theta = 0^\circ, 45^\circ, 90^\circ, 135^\circ$ ) are used. The maximum run length  $L_{max}$  is dependent of the direction and the images size or may be selected arbitrarily. In [31, 68, 69], the Run-Length Matrices are used to characterize images textures with statistical features. They are defined by the following equations, where  $N$  is the number of gray levels in the image,  $L_{max}$  is the maximal run length and  $P$  is the number of pixels in the image. The short run emphasis (SRE) is used to highlight the abundance of short run, inversely, the abundance of long run is appreciate by the long run emphasis (LRE). The feature gray level non-uniformity (GLN) is used to highlight the run distribution uniformity and the run length non-uniformity (RLN) increase when the number of same length run decrease. The run percentage (RP) measure the proportion of run in image or area. Finally the low gray level run emphasis (LGRE) and the high gray level run emphasis (HGRE) are two additional features to the SRE and LRE.

$$SLP = \sum_{n=1}^N \sum_{l=1}^{L_{\max}} M_{\Theta}(n, l) \quad (1)$$

$$SRE = \frac{1}{SLP} \sum_{n=1}^N \sum_{j=1}^{L_{\max}} \frac{M_{\Theta}(n, l)}{l^2} \quad (2)$$

$$LRE = \frac{1}{SLP} \sum_{n=1}^N \sum_{j=1}^{L_{\max}} M_{\Theta}(n, j) \times l^2 \quad (3)$$

$$GLN = \frac{1}{SLP} \sum_{n=1}^N \left( \sum_{l=1}^{L_{\max}} M_{\Theta}(n, l) \right)^2 \quad (4)$$

$$RLN = \frac{1}{SLP} \sum_{l=1}^{L_{\max}} \left( \sum_{n=1}^N M_{\Theta}(n, l) \right)^2 \quad (5)$$

$$RP = \frac{SLP}{P} \quad (6)$$

$$LGRE = \frac{1}{SLP} \sum_{n=1}^N \sum_{l=1}^{L_{\max}} \frac{M_{\Theta}(n, l)}{n^2} \quad (7)$$

$$HGRE = \frac{1}{SLP} \sum_{n=1}^N \sum_{l=1}^{L_{\max}} M_{\Theta}(n, l) \times n^2 \quad (8)$$

### 3.2. Our color adaptation

We propose an original method, cRLM, to adapt the run length matrix for color images. This method is based on color perception criteria: the Just Noticeable Difference (*JND*) and the distance metric  $\Delta E$ <sup>1</sup> between two colors defined by the International Commission on Illumination (CIE). In a study by Mahy [70], a *JND* = 2.3 threshold is used to differentiate the two colors side by side as perceptually different. However, as proposed in [71], a *JND* between 3.5 and 5.0 provides a practical classification of a perceptibility color difference. Preliminary, the *RGB* images are converted into *CIELab* colorimetric space. The run *X* is determined with threshold (*JND*) on the distance  $\Delta E$  between first pixel  $\text{pix}(X_0)$  and the *nth* collinear pixel  $\text{pix}(nt h)$ . While equation 9 is valid, the collinear pixels are added to form a run and run length *L* is determined by the number of valid pixels.

$$\text{pix}(nth) \in \mathbb{X} \Rightarrow \Delta E(\text{pix}(nth), \text{pix}(X_0)) < JND \quad (9)$$

Then, we choose as the representative color of the run, the median color  $C_{med}$  among the colors of the collinear pixels aggregated in the run. This value (equation 10) corresponds to the pixel color that minimizes the cumulative distance on *X*, based on the distances  $\Delta E$ , and represents the best perceptual color representative of the run.

---

<sup>1</sup>  $\Delta E_{ab}^*$  CIE94 - this color difference is applied in the  $L^*a^*b^*$  color space.

$$C_{med} = pix(x) \in \mathbb{X} = \underbrace{\arg \min}_{pix(x) \in \mathbb{X}} \left( \sum_{l=0}^L \Delta E(pix(x), pix(l)) \right) \quad (10)$$

The median color  $C_{med}$  and run length  $L$  are included in the run length matrix  $M_{\Theta}(n, l)$ . There are two cases (see Algorithm 1): if the median color is already present in the matrix or very perceptually near of a present color (within the meaning of JND) then the value is added to the present matrix value for the corresponding color and the run length  $L$ . Otherwise, this median color is added in a new row of the matrix.

Finally, after repeating these operations on all image pixels and for all direction, we obtain four color Run-Length Matrices (cRLM) where each indexed color is perceptually distant of the other present colors in the matrix and corresponds to the median colors of the image runs. As with gray level Run-Length Matrices (RLM), the color image textures can be characterized by using statistical features in equations 1 to 8. Additionally, we recommend merging<sup>2</sup> the color Run-Length Matrices to obtain a general characterization of color textures.

Algorithm 1: Merge  $C_{med}$  and  $L$  in  $M_{\Theta}$

**Data:** Color  $C_{med}$ , run length  $L$ , run length matrix  $M_{\Theta}$   
and list of color in run length matrix  $C_{M_{\Theta}}$   
**Result:** Merge  $C_{med}$  and  $L$  in  $M_{\Theta}$   
initialization :  $\Delta = 0$ ,  $\Delta_{min} = \infty$ ,  $idx = -1$  ;  
**for**  $i=0: \text{size}(C_{M_{\Theta}})$  **do**  
     $\Delta = \Delta E(C_{med}, C_{M_{\Theta}}(i))$ ;  
    **if** ( $\Delta < JND$  &  $\Delta < \Delta_{min}$ ) **then**  
         $\Delta_{min} = \Delta$ ;  
         $idx = i$  ;  
    **end**  
**end**  
**if** ( $idx \neq -1$ ) **then**  
     $M_{\Theta}(idx, L) + = 1$   
**else**  
     $M_{\Theta}.\text{add}(\text{newrow})$ ;  
     $M_{\Theta}(\text{newrow}, L) + = 1$ ;  
**end**

**Algorithm 1:** Merge  $C_{med}$  and  $L$  in  $M_{\Theta}$

<sup>2</sup> process similar to the algorithm 1 but the median color is replaced by the colors in the matrix  $M_{\Theta}$ .

## 4. Application to painting classification

### 3.1. Our color adaptation

We have tried to characterize by cRLM attributes 4 types of paintings: Miro, DeVinci, Monet and a contemporary artist, Larissa Noury. L.Noury and Monet have an abstract style, Monet is one of the famous impressionist and DeVinci is classical painter of the Renaissance. We can see on Figure 1 that Larissa Noury's style is closed to the impressionist style because she paints with color touches and with impressions of motions given by her painting applications by hands moving on the canvas.

Fig. 1 - Painting database

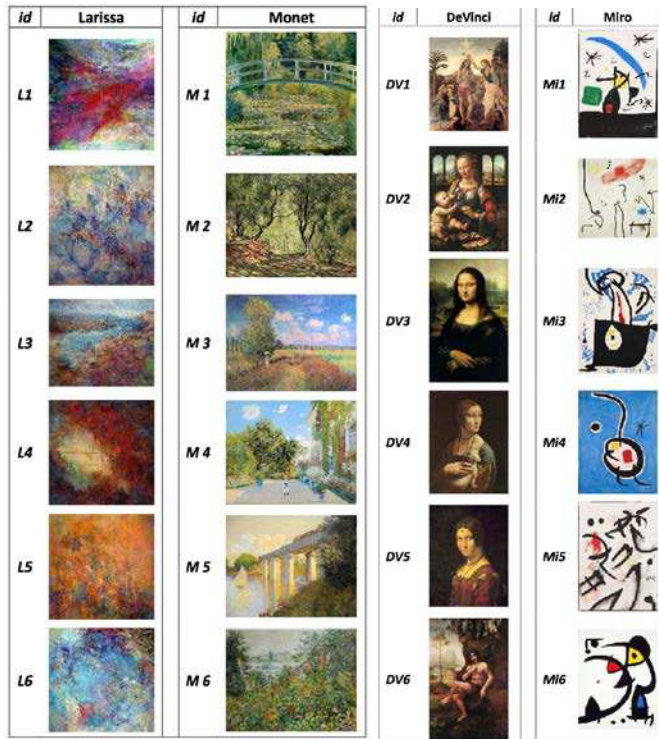

### 3.2 Used methodology for classification

After computing the global cRLM with a JND value of 4, we extract the 8 features (see Equation 1 to 8), described below, associated to the number of colors on each painting. Then, we used a Principal Component Analysis (PCA) to obtain a visual representation of the position of each painting in the features space. On figure 2, we can note that the paintings of each artist are very closed. They form an independent group regarding the paintings of the other artists.

The interpretation of each class and its position is totally linked to a perceptual analysis of the style of paintings. For Miro, we can see that long runs dominate and the color number is very limited. All his paintings forms a really separate class from the others. Despite techniques that may be seen almost similar, L.Noury and Monet paintings are closed but clearly separated. Monet's paintings are very aggregated, corresponding to an homogenous style, with quasi constant color number. L.Noury use very different color pallets, of different sizes. The lengths of the runs are very different from painting to another one. That could be explained by the fact that sometimes she applies only small touches of color, and sometimes she spreads the colors with her fingers, giving greater runs. However, her paintings form a single distinct class. DeVinci is very constant through his works. He uses very few colors with medium run lengths. His class is the most aggregated.

Fig. 2 - Paintings classification, visual representation of PCA.

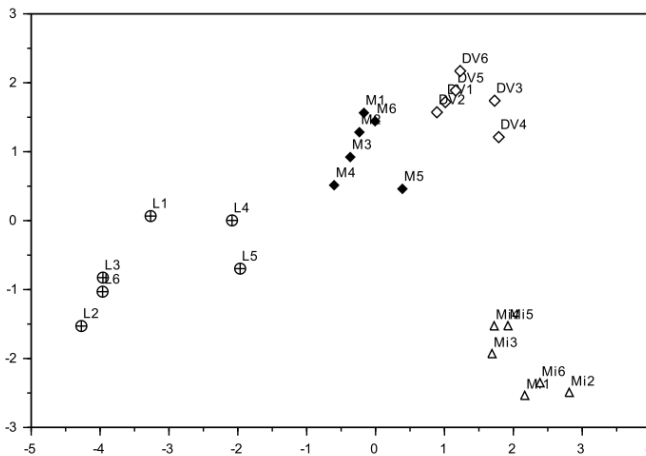

## 5. Conclusion

In this paper we have proposed a new definition for the color Run-Length Matrices (CRLM) taking into account a perceptual point of view by using *JND* and  $\Delta E$  distance in *CIELab*. By computing usual associated parameters, for an application of paintings classification, we show that this cRLM can be helpfully used for textures characterization. Tests have been applied to 6 paintings of 4 different artists with success. After these good results, we can consider to use this color approach in another domains as industrial vision to classify other color textured objects.

**Acknowledgment :** Thanks to French region Aquitaine-Limousin-Poitou-Charentes for the funding of the "e-patrimoine" project in the CPER NUMERIC program.

## References

- [1] L. Shapiro and R. Haralick, "Computer and robot vision," *Reading: Addison-Wesley*, vol. 8, 1992.
- [2] M. Sonka, V. Hlavac, and R. Boyle, *Image processing, analysis, and machine vision, 2nd edition*. PWS Boston, 1998.
- [3] B. Caputo, E. Hayman, M. Fritz, and J.-O. Eklundh, "Classifying materials in the real world," *Image and Vision Computing*, vol. 28, no. 1, pp. 150–163, 2010.
- [4] J. Raju and C. A. D. Durai, "A survey on texture classification techniques," in *IEEE Intern Conf on Information Communication and Embedded Systems (ICICES), 2013* pp. 180–184, 2013.
- [5] B. Schiele and J. L. Crowley, "Object recognition using multidimensional receptive field histograms," in *Computer VisionECCV'96*, pp. 610–619, Springer, 1996.
- [6] M. J. Swain and D. H. Ballard, "Color indexing," *International journal of computer vision*, vol. 7, no. 1, pp. 11–32, 1991.
- [7] M. Gouiffes, C. Collewet, C. Fernandez-Maloigne, and A. Tre' meau, "A study on local photometric models and their application to robust tracking," *Computer Vision and Image Understanding*, vol. 116, no. 8, pp. 896–907, 2012.
- [8] Z. Jiang, M. Yao, and W. Jiang, "Skin detection using color, texture and space information," in *Fuzzy Systems and Knowledge Discovery, 2007. FSKD 2007. Fourth International Conference on*, vol. 3, pp. 366–370, IEEE, 2007.
- [9] V. Arathy and P. S. Babu, "Effective face recognition through color local texture features," *Asian Journal of Information Technology*, vol. 13, no. 3, pp. 170–174, 2014.
- [10] A. Mojsilovic, J. Hu, and R. J. Safranek, "Perceptually based color texture features and metrics for image retrieval," in *Image Processing, 1999. ICIP 99. Proceedings. 1999 International Conference on*, vol. 3, pp. 588–592, IEEE, 1999.
- [11] C.-H. Yao and S.-Y. Chen, "Retrieval of translated, rotated and scaled color textures," *Pattern Recognition*, vol. 36, no. 4, pp. 913–929, 2003.
- [12] M. Gouiffes, C. Fernandez-Maloigne, A. Tre' meau, and C. Collewet, "Color segmentation of ink-characters: application to meat tracability control," in *Image Processing, 2004. ICIP'04. 2004 International Conference on*, vol. 1, pp. 195–198, IEEE, 2004.
- [13] R. Mart'inez, N. Richard, and C. Fernandez, "Alternative to colour feature classification using colour contrast occurrence matrix," in *The International Conference on Quality Control by Artificial Vision 2015*, pp. 953405–953405, Intern Society for Optics and Photonics, 2015.
- [14] A. Ledoux, N. Richard, A.-S. Capelle-Laize', and C. Fernandez-Maloigne, "Perceptual color hit-or-miss transform: application to dermatological image processing," *Signal, Image and Video Processing*, vol. 9, no. 5, pp. 1081–1091, 2015.
- [15] M.-C. Larabi, N. Richard, and C. Fernandez-Maloigne, "Using combination of color, texture, and shape features for image retrieval in melanomas databases," in *Electronic Imaging 2002*, pp. 147–156, International Society for Optics and Photonics, 2001.
- [16] O. Alata, J.-C. Burie, M. Abadi, A. Moussa, C. Fernandez-Maloigne, *et al.*, "Parametric models of linear prediction error distribution for color texture and satellite image segmentation," *Computer Vision and Image Understanding*, vol. 115, no. 8, pp. 1245–1262, 2011.
- [17] M. Tuceryan and A. Jain, "texture analysis, the handbook of pattern recognition and computer vision, by ch," *Chen, LF. Pau, PSP Wang (ed) Word Scientific Publishing Co*, 1998.
- [18] R. M. Haralick, "Statistical and structural approaches to texture," *Proceedings of the IEEE*, vol. 67, no. 5, pp. 786–804, 1979.
- [19] A. Materka, M. Strzelecki, *et al.*, "Texture analysis methods—a review," *Technical university of lodz, institute of electronics, COSTB11 report, Brussels*, pp. 9–11, 1998.
- [20] S. F. Ershad, "Color texture classification approach based on combination of primitive pattern units and statistical features," *arXiv preprint arXiv:1109.1133*, 2011.
- [21] T. Ojala, K. Valkealahti, E. Oja, and M. Pietik'inen, "Texture discrimination with multidimensional distributions of signed gray-level differences," *Pattern Recognition*, vol. 34, no. 3, pp. 727–739, 2001.
- [22] L. S. Davis, S. A. Johns, and J. Aggarwal, "Texture analysis using generalized co-occurrence matrices," *IEEE Trans on Pattern Analysis and Machine Intelligence*, no. 3, pp. 251–259, 1979.
- [23] J. Yang and J. Guo, "Image texture feature extraction method based on regional average binary gray level difference co-occurrence matrix," in *Virtual Reality and Visualization (ICVRV)*,

2011 International Conference on, pp. 239–242, IEEE, 2011.

- [24] D. J. Marceau, P. J. Howarth, J.-M. M. Dubois, D. J. Gratton, *et al.*, “Evaluation of the grey-level co-occurrence matrix method for land-cover classification using spot imagery,” *IEEE Transactions on Geoscience and Remote Sensing*, vol. 28, no. 4, pp. 513–519, 1990.
- [25] J. Haddon and J. Boyce, “Co-occurrence matrices for image analysis,” *Electronics & communication engineering journal*, vol. 5, no. 2, pp. 71–83, 1993.
- [26] I. M. Elfadel and R. W. Picard, “Gibbs random fields, cooccurrences, and texture modeling,” *IEEE Trans on Pattern Analysis and Machine Intelligence*, vol. 16, no. 1, pp. 24–37, 1994.
- [27] V. Kovalev and M. Petrou, “Multidimensional co-occurrence matrices for object recognition and matching,” *Graphical Models and Image Processing*, vol. 58, no. 3, pp. 187–197, 1996
- [28] B. Pathak and D. Barooah, “Texture analysis based on the gray-level co-occurrence matrix considering possible orientations,” *International Journal of Advanced Research in Electrical, Electronics and Instrumentation Engineering*, vol. 2, no. 9, pp. 4206–4212, 2013.
- [29] A. Gebejes and R. Huertas, “Texture characterization based on grey-level co-occurrence matrix,” *Conference Of Informatics And Management Sciences, ICTIC*, vol. 2013, pp. 375–378, 2013.
- [30] T. Ojala, M. Pietikainen, and T. Maenpää, “Multiresolution gray-scale and rotation invariant texture classification with local binary patterns,” *Pattern Analysis and Machine Intelligence, IEEE Transactions on*, vol. 24, no. 7, pp. 971–987, 2002.
- [31] M. M. Galloway, “Texture analysis using gray level run lengths,” *Computer graphics and image processing*, vol. 4, no. 2, pp. 172–179, 1975.
- [32] F. Huet and J. Mattioli, “A textural analysis by mathematical morphology,” in *Mathematical Morphology and its Applications to Image and Signal Processing*, pp. 297–304, Springer, 1996.
- [33] J. M. Coggins and A. K. Jain, “A spatial filtering approach to texture analysis,” *Pattern recognition letters*, vol. 3, no. 3, pp. 195–203, 1985.
- [34] A. C. Bovik, M. Clark, and W. S. Geisler, “Multichannel texture analysis using localized spatial filters,” *Pattern Analysis and Machine Intelligence, IEEE Transactions on*, vol. 12, no. 1, pp. 55–73, 1990.
- [35] A. C. Bovik, “Analysis of multichannel narrow-band filters for image texture segmentation,” *Signal Processing, IEEE Transactions on*, vol. 39, no. 9, pp. 2025–2043, 1991.
- [36] A. K. Jain and F. Farrokhnia, “Unsupervised texture segmentation using gabor filters,” in *Systems, Man and Cybernetics, 1990. Conference Proceedings., IEEE International Conference on*, pp. 14–19, IEEE, 1990.
- [37] T. Randen and J. H. Husoy, “Filtering for texture classification: A comparative study,” *Pattern Analysis and Machine Intelligence, IEEE Transactions on*, vol. 21, no. 4, pp. 291–310, 1999.
- [38] T. Randen and J. H. Husoy, “Texture segmentation using filters with optimized energy separation,” *IEEE Transactions on Image Processing*, vol. 8, no. 4, pp. 571–582, 1999.
- [39] M. A. Hoang, J.-M. Geusebroek, and A. W. Smeulders, “Color texture measurement and segmentation,” *Signal processing*, vol. 85, no. 2, pp. 265–275, 2005.
- [40] F. Mourougaya, P. Carre, and C. Fernandez-Maloigne, “Combined statistical-fractal wavelets signatures for texture recognition,” in *Optics East 2006*, pp. 63830N–63830N, International Society for Optics and Photonics, 2006.
- [41] L. Wang and J. Liu, “Texture classification using multiresolution markov random field models,” *Pattern recognition letters*, vol. 20, no. 2, pp. 171–182, 1999.
- [42] S. Tominaga, “A color classification algorithm for color images,” in *Pattern Recognition*, pp. 163–172, Springer, 1988.
- [43] S. Sergyaev, “Color content-based image classification,” in *5th Slovakian-Hungarian Joint Symposium on Applied Machine Intelligence and Informatics*, pp. 427–434, Citeseer, 2007.
- [44] M. E. Celebi and G. Schaefer, *Color medical image analysis*, vol. 6. Springer Science & Business Media, 2012.
- [45] Y.-C. Cheng and S.-Y. Chen, “Image classification using color, texture and regions,” *Image and Vision Computing*, vol. 21, no. 9, pp. 759–776, 2003.
- [46] M. Mirmehdi and M. Petrou, “Segmentation of color textures,” *Pattern Analysis and Machine Intelligence, IEEE Transactions on*, vol. 22, no. 2, pp. 142–159, 2000.
- [47] M. Pietikainen, T. Maenpää, and J. Viertola, “Color texture classification with color histograms and local binary patterns,” in *Workshop on Texture Analysis in Machine Vision*, pp. 109–112, Citeseer, 2002.
- [48] T. Maenpää, M. Pietikainen, and J. Viertola, “Separating color and pattern information for color texture discrimination,” in *Pattern Recognition, 2002. Proceedings. 16th International*



- Conference on*, vol. 1, pp. 668–671, IEEE, 2002.
- [49] C.-C. Chang and L.-L. Wang, “Color texture segmentation for clothing in a computer-aided fashion design system,” *Image and vision computing*, vol. 14, no. 9, pp. 685–702, 1996.
  - [50] M. Hauta-Kasari, J. Parkkinen, T. Jaaskelainen, and R. Enz, “Generalized co-occurrence matrix for multispectral texture analysis,” in *Pattern Recognition, 1996., Proceedings of the 13th International Conference on*, vol. 2, pp. 785–789, IEEE, 1996.
  - [51] O. Alata, J.-C. Burie, A. Moussa, C. Fernandez-Maloigne, *et al.*, “Choice of a pertinent color space for color texture characterization using parametric spectral analysis,” *Pattern Recognition*, vol. 44, no. 1, pp. 16–31, 2011.
  - [52] O. Alata, J.-C. Burie, C. Fernandez-Maloigne, *et al.*, “Color spectral analysis for spatial structure characterization of textures in ihls color space,” *Pattern Recognition*, vol. 43, no. 3, pp. 663–675, 2010.
  - [53] V. Arvis, C. Debain, M. Berducat, and A. Benassi, “Generalization of the cooccurrence matrix for colour images: application to colour texture classification,” *Image Analysis & Stereology*, vol. 23, no. 1, pp. 63–72, 2011.
  - [54] A. Ledoux, O. Lосson, and L. Macaire, “Texture classification with fuzzy color co-occurrence matrices,” in *International Conference on Image Processing (ICIP)*, 2015.
  - [55] A. Martinez, N. Richard, and C. Fernandez-Maloigne, “Colour contrast occurrence matrix: a vector and perceptual texture feature,” in *Color Imaging Conference, IS&T*, 2015.
  - [56] M. Crosier and L. D. Griffin, “Texture classification with a dictionary of basic image features,” in *Computer Vision and Pattern Recognition, 2008. CVPR 2008. IEEE Conference on*, pp. 1–7, IEEE, 2008.
  - [57] A. Porebski, N. Vandenbroucke, and L. Macaire, “Haralick feature extraction from lbp images for color texture classification,” in *Image Processing Theory, Tools and Applications, IPTA 2008. First Workshops on*, pp. 1–8, IEEE, 2008.
  - [58] C. Zhu, C.-E. Bichot, and L. Chen, “Multi-scale color local binary patterns for visual object classes recognition,” in *Pattern Recognition (ICPR), 2010 20th International Conference on*, pp. 3065–3068, IEEE, 2010.
  - [59] S. Banerji, A. Verma, and C. Liu, “Lbp and color descriptors for image classification,” in *Cross Disciplinary Biometric Systems*, pp. 205–225, Springer, 2012.
  - [60] M. Pietikinen, T. Maenpää, and J. Viertola, “Color texture classification with color histograms and local binary patterns,” in *Workshop on Texture Analysis in Machine Vision*, pp. 109–112, Citeseer, 2002.
  - [61] S. Liapis and G. Tziritas, “Color and texture image retrieval using chromaticity histograms and wavelet frames,” *Multimedia, IEEE Transactions on*, vol. 6, no. 5, pp. 676–686, 2004.
  - [62] J. Angulo, “Morphological colour operators in totally ordered lattices based on distances: Application to image filtering, enhancement and analysis,” *Computer Vision and Image Understanding*, vol. 107, no. 1, pp. 56–73, 2007.
  - [63] E. Aptoula and S. Lefèvre, “On morphological color texture characterization,” in *International Symposium on Mathematical Morphology (ISMM)*, pp. 153–164, 2007.
  - [64] M. Ivanovici, A. Caliman, N. Richard, and C. Fernandez-Maloigne, “Towards a multivariate probabilistic morphology for colour images,” in *Conference on Colour in Graphics, Imaging, and Vision*, pp. 189–193, Society for Imaging Science and Technology, 2012.
  - [65] A. Ledoux, N. Richard, A.-S. Capelle-Laize, and C. Fernandez-Maloigne, “Toward a complete inclusion of the vector information in morphological computation of texture features for color images,” in *Image and Signal Processing*, pp. 222–229, Springer, 2014.
  - [66] M. Ivanovici, N. Richard, and C. Fernandez-Maloigne, “Fractal dimension of colour fractal images,” *IEEE Transactions on Image Processing*, vol. 99, p. 10p, 2010.
  - [67] C. Fernandez-Maloigne, *Advanced color image processing and analysis*. Springer Science & Business Media, 2012.
  - [68] A. Chu, C. M. Sehgal, and J. F. Greenleaf, “Use of gray value distribution of run lengths for texture analysis,” *Pattern Recognition Letters*, vol. 11, no. 6, pp. 415–419, 1990.
  - [69] X. Tang, “Texture information in run-length matrices,” *Image Processing, IEEE Transactions on*, vol. 7, no. 11, pp. 1602–1609, 1998.
  - [70] M. Mahy, L. Eycken, and A. Oosterlinck, “Evaluation of uniform color spaces developed after the adoption of cielab and cielv,” *Color Research & Application*, vol. 19, no. 2, pp. 105–121, 1994.
  - [71] W. Mokrzycki and M. Tatol, “Colour difference  $\delta E$  – a survey,” *Machine Graphics & Vision*, vol.



## **5. COLOUR AND RESTORATION**



# The color of fluorescence: non-invasive characterization of fluorescent pigments used in contemporary art

<sup>1</sup>Marco Gargano, <sup>1</sup>Letizia Bonizzoni, <sup>1</sup>Lorenzo Cerami, <sup>2</sup>Serena Francone and <sup>1</sup>Nicola Ludwig

<sup>1</sup>Department of Physics, Università degli Studi di Milano, via Celoria 16, Milan, marco.gargano@unimi.it

<sup>2</sup>Conservator of Contemporary Art, Como – materiadarte@gmail.com

## 1. Introduction

Specific pigments used in contemporary art show an intense visible fluorescent light when illuminated by UV radiation: this can be used to obtain combination of colors and light effects. A typical example comes from the works of the painter Mario Agrifoglio that based his technique to the study of mixing and layering of fluorescent and non-fluorescent pigments realizing a unique effect. In fact, the color perception can be different according with the type of light source used to illuminate the paintings; in some cases, the result is inverted: black pigments under visible light became white under UV and white pigments in visible light turn black in UV light due to the absence of fluorescence. The authors analyzed some of the coloring materials used by the artist and left in his workshop after his death. Starting from these materials, 18 samples have been prepared varying concentration and mixtures. Measurements were made through multidisciplinary technique: imaging techniques, colorimetric measurements, spectral techniques and elemental analyses.

This research is part of a project aimed at conserving Agrifoglio's paintings. The characterizations of the materials used by the artist is critical to make the right choices in the intervention phase. After verifying that the author used mixtures of pigments and colors to obtain principal hues in his paintings, the analyses presented in this work were carried out on the original raw materials left by the artist.

## 2. The UV-induced visible fluorescence and color appearance

These particular paintings were made with the purpose of producing an effect of distortion of perception. Displaying them in two different illuminants (fig. 1) is required in order to completely understand the artist's message [1]. The pigments used are the result of a long research activity in achieving a metamerism and producing an opposing behavior visible under ultraviolet light. The knowledge of the materials used by the author is therefore of particular importance, in order to investigate the author's innovative technique and technology and to be able to provide the tools needed for proper conservation [2, 3].

The opportunity given by this case study, also allows us to answer to interesting questions about encoding colorimetric materials designed to work with non-visible light. Colorimetric spaces are inadequate to define colorimetrically such materials and what it is possible to give is a spectroscopic description and comparison of the same material under different lights together with an elemental analysis to know the composition [4].

In addition, what is interesting from a scientific point of view, but also for art historians and conservators, is whether the author has worked with off-the-shelf

pigments or prepared them adding fluorescent substance to non-fluorescent pigments to differentiate them under UV light.

An answer to this question can be extremely important for the purpose of an aesthetic intervention in the conservation phase, in case of lacunas in the paint film. In fact, retouching Agrifoglio's paintings requires to find the right material not to compromise the artist's message with a different metamerism, both under visible and UV light. For the same reason, it could be interesting to analyze how a particular fluorescent substance added to non-fluorescent pigments can modify their perception under UV light, as to evaluate the use of this same substance to obtain variations of fluorescence emissions.



Fig. 1 – A work by Mario Agrifoglio under visible light (on the left) and under UV light (on the right).

### 3. Colorimetric, spectroscopic and elemental description of fluorescent pigments.

The work consisted in the analysis of some original materials which have been left in the artist's Studio after his death (fig. 2). Some samples were made from small containers with pigments but in many cases it is not possible to find any indication on the packaging. From what is known of the author's technique, it is likely that the artist has mainly used ready-made colors. However, all the tests found in the workshop, prove that in some cases fluorescent compound have been added to non-fluorescent pigment. Well-known fluorochromes are the *stilbene*, the *coumarins* and the *imidazolines* which absorbs in the UV portion of the spectrum and re-emit in the blue portion of the visible spectrum and the fluorescein, a synthetic organic compound as well, with a peak excitation at 494 nm and with a peak emission at 521 nm [5]. However, unfortunately, these are only few compound that can be used for art pigments [6-8].

Measurements were made using a multidisciplinary non-invasive approach and the techniques that have been used are listed in the following parts.

### **3.1. UV-induced visible fluorescence imaging**

Samples were shot under 2 x 72W, 365 nm-UV light at 160 m distance placing light sources at 45° to the normal of the samples. To allow us to compare UV fluorescence behavior, visible images were shot under tungsten halogen lamp with a correlated color temperature of 2850 K. A Nikon D800E was used to take photos of both UV and Vis images [9].

### **3.2. Colorimetric measurements**

A standard commercial colorimeter Minolta CR-400, Xenon Lamp, D65 illuminant, d:0° geometry, was used. Data are the results of an average of three measures and the CIEL\*a\*b\* color system was used to represent these data [10].

### **3.3. UV and Visible Spectroscopy**

Spectroscopic measurements were performed by means of a Fiber Optic Spectrometer (FORS) (HR4000, Ocean Optics, 2.7 nm spectral resolution) using two different experimental set-up.

-Measure of induced Fluorescence: a Xenon Arc Lamp was used with a 400 short pass filter to block radiation with  $\lambda > 400$  nm. Then the induced fluorescence was measured in *emission counts* mode.

-Measure of Spectral Reflectance Factor: a halogen lamp (HL2000 Ocean Optics) was used with the aim to measure the visible spectra of the sample avoiding effects of induced fluorescence. In fact, this halogen lamp has no emission in the UV and a very low emission in the blue range of the spectrum. The spectrophotometer was calibrated on white and black reflectance standards (Spectralone 99% and dark trap).

### **3.4. X-Ray fluorescence spectroscopy**

Elemental analyses were performed through X-Ray fluorescence spectrometry; characteristic X-Ray emissions were measured using a portable spectrometer Assing LITHOS 3000, with excitation monochromatic energy corresponding to Molybdenum K $\alpha$  line. The detector is a Si-PIN Peltier cooled. The area irradiated is circularly shaped with a radius of approx. 4 mm. Measurements were made at 25 kV, 0.3 mA, 60 sec.

## **4. Results.**

Measurements allowed understanding part of the *modus operandi* of the artist. fluorescein has been used only for red colors, in fact, as showed in figure 4, it emits at wavelengths above 500 nm. Blues were realized using copper pigment with optical brightener. FORS analysis allowed identifying blue as a phthalocyanine but for the fluorescent part is not possible an exact identification. It is interesting the result for the black sample (D2 – fig.3) that under UV light become brighter with a peak fluorescent emission at 445 nm and 590 nm (fig. 4). In addition, this material was made using a copper-based pigment. For white samples (C1, C2, fig. 3)

tetrahydropyrene was recognized from the peak in the emission spectra of fluorescence (fig. 5) and confirmed by XRF and FORS analyses.

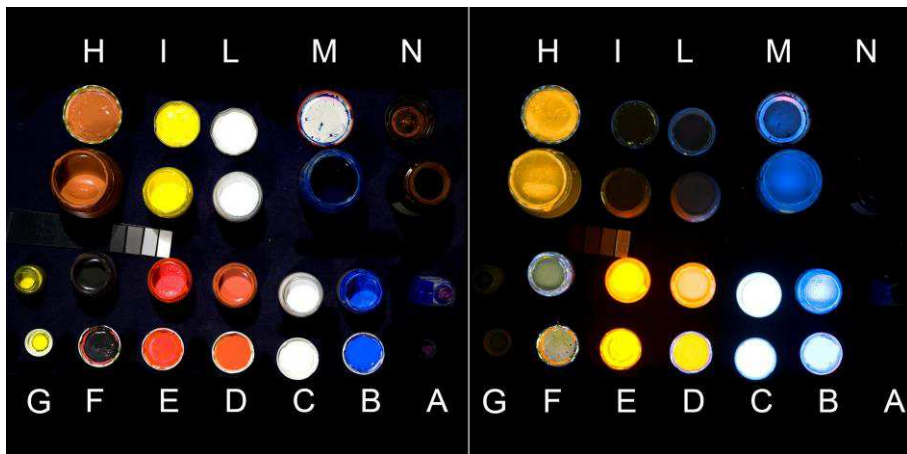

Fig. 2 – Original flasks with colors used by the painter. On the left, the image in visible light, on the right the image in UV-induced fluorescence. Four grey levels of non-fluorescent material (Spectralone) were inserted as reference.

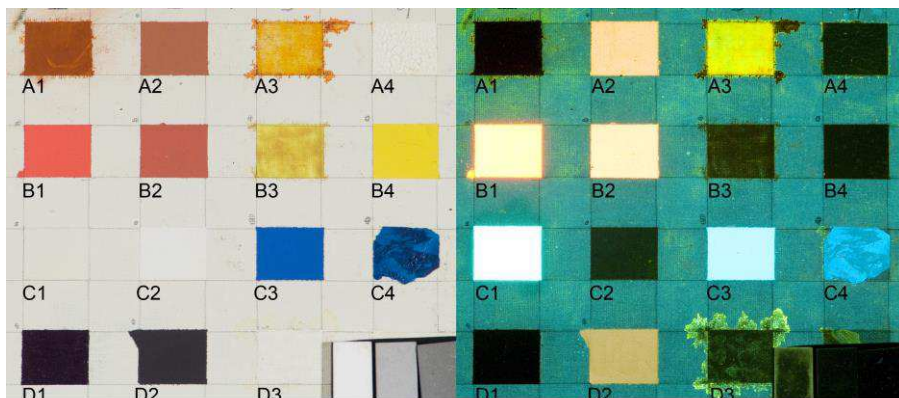

Fig. 3 – Paint layers realized with the original workshop colors used by the painter. On the left, the image in visible light, on the right the image in UV-induced fluorescence. Four grey levels of non-fluorescent material (Spectralone) were inserted as reference.



Sample	L*	a*	b*
A1	42.01	36.03	39.07
A2	53.39	30.96	31.43
A3	78.33	13.84	72.57
A4	95.10	-0.59	7.28
B1	65.07	75.25	57.01
B2	56.70	46.70	36.44
B3	75.67	-0.67	69.82
B4	87.61	-4.73	91.26
C1	91.34	-2.42	13.21
C2	94.92	-0.92	4.32
C3	42.81	1.48	-44.94
C4	31.70	-0.06	-27.29
D1	25.09	15.87	-4.66
D2	30.16	3.29	1.46
D3	92.74	-0.96	5.83

Tab. 1 – Colorimetric data of samples in CIEL\*a\*b\* color space.

Sample	Description on the container	Element	Note
A1	Fluorescein powder, with water and egg tempera	Ti, Cl	Cl from the solvent
A2	--	Ca, Zn	
A3	Fluorescein powder, with water and acrylic binder	non detectable elements	Organic or low-Z components
A4	Fluorescein powder, titanium white with water and acrylic binder	Ti, Cl	
B1	Rosso granata	non detectable elements	
B2	Bianco	Ca	B1 with calcium white
B3	--	Cl	
B4	--	Ca	High calcium counts
C1	--	non detectable elements	Organic or low-Z components
C2	Bianco di titanio	Ca, Ti	Ti from the background
C3	--	Cu	
D1	No alcool	Cu, Cl	Similar to c3
D2	Inchiostro	Cu	High Cu peak contribution
D3	Bianco	Zn, Ca	

Tab. 2 – Results of the XRF analysis.

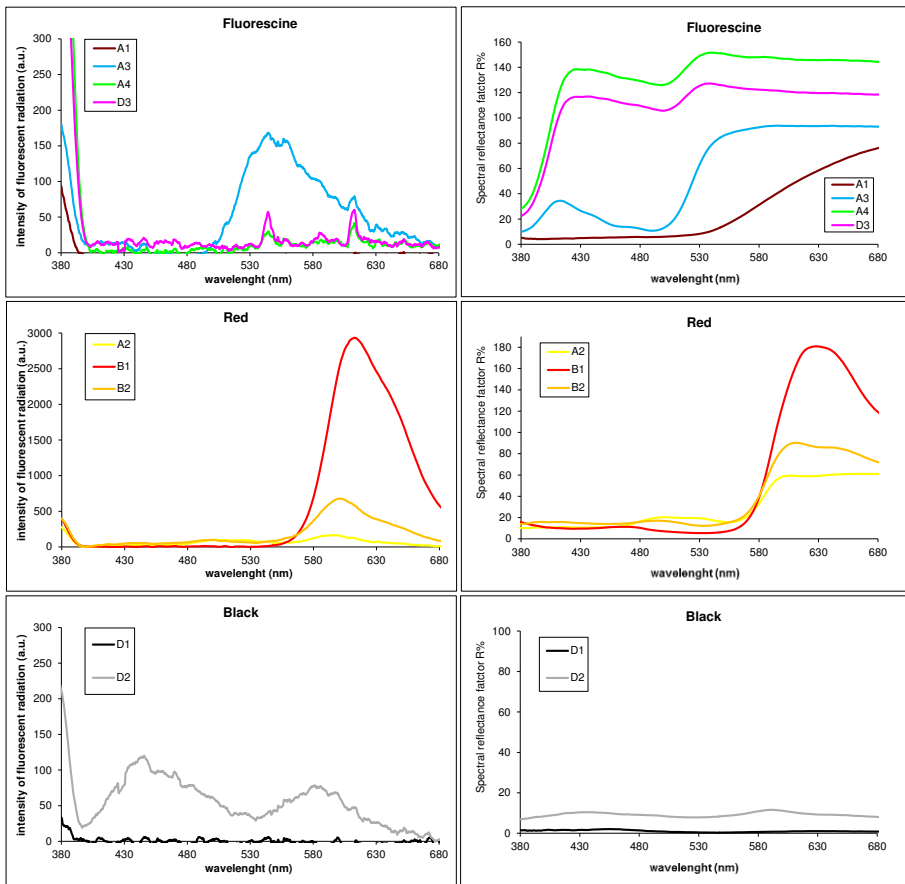

Fig. 4 – Intensity of fluorescence (left) and spectral reflectance factor (right) of the realized samples.

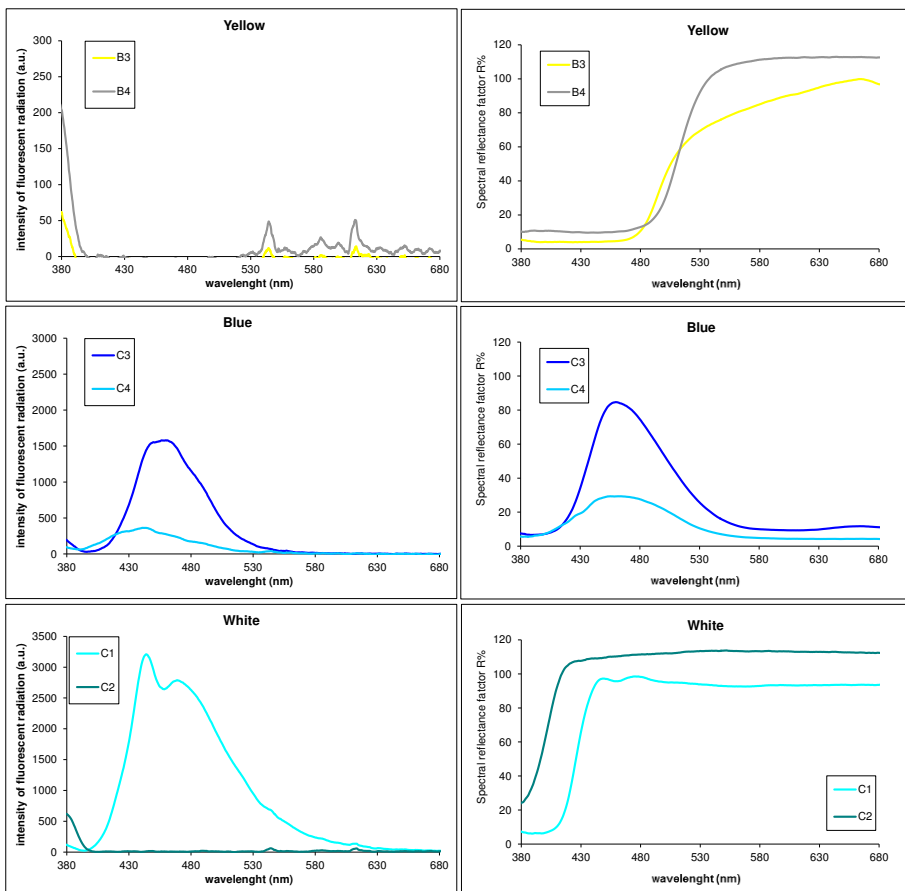

Fig. 5 – Intensity of fluorescence (left) and spectral reflectance factor (right) of the realized samples.

## 5. Conclusions

Thanks to the analyses carried out on the materials found in the artist's Studio, it has been possible to evaluate the use of fluorescent substances, like fluorescein and optical brighteners, to obtain variation in fluorescence emission of non-fluorescent pigments. The elemental identification is useful to find the right pigment to use in retouching during a conservative intervention.

## References

- [1] Agrifoglio, Fabio, Mario “Agrifoglio. Compesazionismo analitico condizionato. Periodo 1970-2005”, Ed. Fondazione Mario Agrifoglio.
- [2] Francone, S., et al. “Fluorescent paint by Mario Agrifoglio. Study of the technique and material characterization through non-invasive analyses”, in Selva Bonino, V. E., “Dall’olio all’acrilico, dall’Impressionismo all’arte contemporanea”, proceedings of the VII International Congress “Colore & Conservazione” by Cesmar7, Politecnico of Milan, 13-14 november 2015.
- [3] De Winter, Stefanie, “Conservation problems with paintings containing fluorescent layers of paint”, CeRoART, Hors Série, EGG 2010 Horizons.
- [4] Billmeyer and Saltzman’s: principles of color technology. 3rd ed. New York: John Wiley and Sons (2000): 95-105.
- [5] Allendorf, M. D., et al. “Luminescent metal–organic frameworks”. *Chemical Society Reviews* 38.5 (2009): 1330-1352.
- [6] Harelstad, R. Ellen, David M. Burns, and Lee A. Pavelka. “Durable fluorescent organic pigments and methods of making”. U.S. Patent No. 6,533,961. 18 Mar. 2003.
- [7] Pelagotti, A., et al. “Multispectral UV fluorescence analysis of painted surfaces”. Proceedings of 14th European Signal Processing Conference (EUSIPCO’06). 2006.
- [8] Pelagotti, Anna, et al. “A study of UV fluorescence emission of painting materials”. Art ‘05–8th International Conference on Non-Destructive Investigations and Microanalysis for the Diagnostics and Conservation of the Cultural and Environmental Heritage. Lecce, Italy, 2005.
- [9] Cosentino, Antonino. “Practical notes on ultraviolet technical photography for art examination”. *Conservar Património* 21 (2015): 54.
- [10] CIE15:2004.Commission Internationale de l’Eclairage. Colorimetry - Technical Report. 3rd Ed.

# Innovative methods for a recognizable gold leaf integration

<sup>1</sup>Roberta Capezio, <sup>1</sup>Tiziana Cavaleri, <sup>2</sup>Gabriele Piccablotto,

<sup>3</sup>Marco Pisani, <sup>1</sup>Paolo Triolo, <sup>3</sup>Massimo Zucco

<sup>1</sup>Centro per la Conservazione e il Restauro *La Venaria Reale*, roberta.capezio@centrorestaurovenaria.it, tiziana.cavaleri@centrorestaurovenaria.it, paolo.triolo@centrorestaurovenaria.it

<sup>2</sup>LAMSA, Dipartimento Architettura Design, Politecnico di Torino, gabriele.piccablotto@polito.it

<sup>3</sup>Istituto Nazionale di Ricerca Metrologica, m.pisani@inrim.it, m.zucco@inrim.it

## 1. Introduction: gold leaf gilding and integration techniques

Since ancient Egyptian times (*Tomb of Kha and Merit*, 28<sup>th</sup> dynasty, *Museo Egizio, Turin*) to present, gold leaf gilding has been highly appreciated for giving the artifacts the brightness of the precious metal: gold represents the sun, the life-giving star therefore closely related to the divine. In the Christian iconography, gold represents Jesus, the *Sol Invictus* coming to save the humankind from the Adam's original sin. Many authors as Pliny the Elder (AD 23 – August 25, AD 79) and Theophilus presbyter (12<sup>th</sup> century) speak about the gilding techniques [1, 2]; Cennino Cennini (1370 – 1427) describes the use of gold backgrounds for enhancing colours of polychrome panel paintings [3].

Among several methods of gilding, the so-called *guazzo* technique was the oldest and the most complex one. After plastering the wooden support, it required to spread a layer of Armenian bole (reddish clay) and fish glue upon it and then to apply the gold leaf that could be subsequently burnished (flattened) by means of some in agate tools: burnishing was the only operation that made the leaf so smooth and bright, exploiting the bole's plasticity. Other later gilding techniques required for instance the application of an oil-layer (*missione*) underneath the gold leaf, then replaced by the use of an acrylic-layer, not suitable for the burnishing operation.

According to the modern concept of conservation, integration of the gold leaf's lacunae presents practical and conceptual difficulties, as it has to present a very peculiar artistic technique (a metal foil applied on a bole layer) satisfying in the meantime three requirements: recognizability, re-tractability and aesthetic.

Many proposals have spontaneously risen during the last years [4-8]. The *tratteggio* technique [9] used by the Superior Institute for Conservation and Restoration (ISCR) in Rome, the *chromatic selection* proposed by the Opificio delle Pietre Dure (OPD) in Florence, the *puntinato* integration [10, 11] make use of watercolours – applied upon the gold leaf or directly on the plaster layer – in order to guarantee the recognizability of the intervention (Fig. 1). But the result is not so aesthetic, because of a sharp brightness difference between integration and original gilding<sup>1</sup>.

So, the integration with *guazzo* remains as in antiquity the only technique providing so brilliant surfaces, the only one entirely answering the aesthetic requirement, and this is why it is actually required in some cases. Thus the problem of the recognizability requirement appears.

---

<sup>1</sup> Other attempts were made in order to reduce this difference, for instance darkening the plaster layer underneath the gold leaf or by adding small amounts of metal gold (*oro in conchiglia*) or of shiny mineral powders (mica powder).

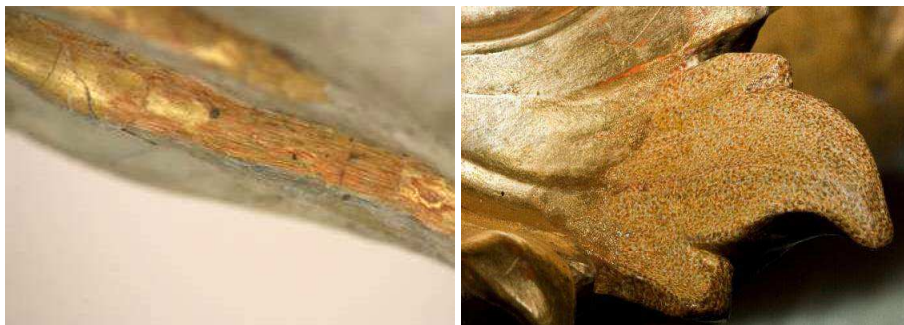

Fig. 1 – Conservative interventions carried out at “Centro per la Conservazione e il Restauro La Venaria Reale”: gold leaf integration with *cromatic selection* (watercolours applied on plaster) on a wooden furnishing by G.Marocco and M.Monticelli, Palazzina di caccia di Stupinigi, Turin, 1731-1739 (left, corresponding to a detail of about 4 cm wide); with *puntinato* (watercolours directly applied upon the plaster) on “Doppio corpo” by P. Piffetti, Palazzo del Quirinale, Rome, 18th century (right, corresponding to a detail of about 7 cm wide).

## 2. Study for a recognizable gold leaf integration: materials and method

The aim of our study was to make the integration with *guazzo* – which already satisfies the aesthetic requirement of the intervention – also recognizable (and localizable), by means of non-invasive and possibly low-cost imaging techniques.

Starting from previous experimentation<sup>2</sup> and from other published research on plaster formulation [12], we decided to modify the *guazzo* traditional technique by adding “particular” pigments to the bole layer.

As “drugging” pigments we chose Egyptian blue (n. 10060<sup>3</sup>, hereafter called EB, average particle size < 120 μ), cadmium red and cadmium yellow (n. 21120, CR, and n. 21040, CY, respectively, both with average particle size approximately 0.5 μ), manganese violet (n. 45350, MV, average particle size 2.3 μ) and cobalt blue (n. 45700, CB, average particle size 4.2 μ) basing on the possibility of detecting them in visible-induced luminescence (VIL) [13-15]. EB, in particular, exhibits an exceptionally intense emission in the near-infrared region ( $\lambda$  max = 910 nm) when stimulated by visible light [16-18]. We selected also lac dye (n. 36020, LD), Indian yellow (n. 60602, IY), wernerite (n. 12700, WE, particle size 63-100 μm) and diopside (n. 12720, DI, particle size 0-63 μm) basing on the possibility of detecting them in ultraviolet fluorescence (UVF).

In the first three samples we made (Fig. 2) gold leaf is applied on a traditional Armenian bole layer (as reference), on a layer of 100% EB and on a layer of bole and EB (10% in weight). Here, EB was not ground and had a large grain size.

These samples immediately highlighted two important aspects to take into account in our research. On the one hand, the presence of micro holes due to the beating of the leaf, will have grown during the burnishing depending on the drugging

<sup>2</sup> We had already pursued something similar through an experimentation on a not-gilded wooden furniture, where we had added small amounts of bismuth oxide into the plaster-based filler in order to make the intervention detectable through X-rays.

<sup>3</sup> All the listed materials with their code and the average particle size, when declared, are pigment powders produced by Kremer Pigmente GmbH & Co.KG; Indian yellow in powder is a product by Bresciani SRL.

pigment's granulometry, affecting the aesthetic and the colour appearance of the gilding [19]. On the other hand, the holes will have facilitated the recognizability, allowing for example the underneath layer's UV fluorescence to pass through the leaf and be recorded.

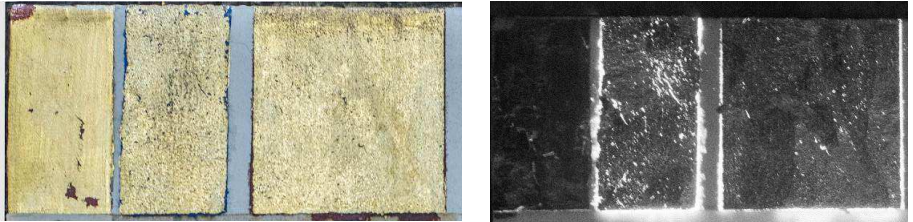

Fig. 2 – Preliminary test: picture in visible light and VIL of the samples, from left to right: gold leaf on bole (3 cm high per 1.5 cm wide); gold leaf on Egyptian blue layer (3 cm high per 1.5 cm wide); gold leaf on bole mixed with 10% in weight of Egyptian blue (3 cm high per 3.5 cm wide).

For the complete set of 50 samples (Fig. 3), we thus considered both to ground some pigments and to use them in different percentages, in order to find the minimum detectable amount of drugging pigment and so a solution for satisfying in the meantime the aesthetic and the recognizability requirements of the integration. Drugging pigments were spread alone (first column, Fig. 3) and then added to the bole in percentages of 2%, 5%, 10%, 15%, 20% and 25% in weight (from left to right); only WE and DI were added to the bole in 33% in weight; traditional fish glue was used as binding medium. The gold leaf was then applied, following the *guazzo* technique, on the lower part of each draft and only the half on the right was burnished. For this panel, EB underwent a grinding process before by means of a mortar on glass; WE and DI were added to the dry bolus then spreading the paint for three times to obtain a substantial draft. Finally, we prepared the references for our study (Fig. 3, the small panel on the bottom): a sample of reddish Armenian bole, our *bole reference*, and a bigger sample simulating the gilding of an artwork, with the gold leaf applied on the Armenian bole and then burnished (the “upside down T” area), that was our *gilding reference*.

For evaluating the aesthetic requirement of the samples simulating the gold leaf integration, we measured and calculated their colour differences ( $\Delta E_{00}$ ) compared to the respective references (*bole reference* or *gilding reference*). We used a Konica Minolta CM700d spectrophotometer, working in the 1976 CIELAB colour space in SCE condition with standard illuminant D65 and standard observer 10°, and the CIEDE2000 formula [20]. Results were related and compared to the conservator's observations and with some pictures of the samples acquired in video-microscopy.

For evaluating the recognizability requirement of the samples, possibly with a low-cost tool, we performed multispectral investigations on the panel, by exploiting those portions of the electromagnetic spectrum that could be relievable by conventional CCD and CMOS sensors (300 nm – 950 nm). We thus acquired the traditional ultraviolet fluorescence (UVF), the ultraviolet reflectography (UVR) and the infrared reflectography (IRR) but also we used the more recent visible induced luminescence (VIL) technique. We used a Nikon D810 camera for the pictures in visible light and the UVF, and a Nikon D810 UVIR for the UVF, the IRR and the

VIL. Filter sets for Nikon cameras included Hoya IRUV cut, Peca 900 (87), Peca 900, X-nite BP1, all lighting equipments (Ianiro 800 W D65, Labino UV flood) set up in diffuse mode. Colour-correction was based on a GretagMacbeth© Colour Chart, Konica Minolta ceramic white pad 99%, Kremer Pigmente GmbH & Co.KG Egyptian blue pad; flat mode subtraction applied to UVF.



Fig. 3 – Set of samples (3 cm high per 3.5 cm wide). Drugging pigments (EB, CR, CY, MV, CB, LD, IY, WE, DI) along the first column. Along the lines: bole mixtures prepared with 2%, 5%, 10%, 15%, 20% and 25% in weight of the drugging pigment on the left, and with 33% in weight of WE and DI, where the lower part is covered by the gold leaf and only the half on the right is burnished. On the bottom: references for the study (the reddish one is the *bole reference*; the *gilding reference* is the bigger “upside down T” area).

Finally, on those samples that satisfied the aesthetic and/or recognizability requirements, we studied how they would appear, with respect to the reference, when illuminated with different LED sources. So, in a first step, we acquired the



Spectral Power Distribution (SPD)<sup>4</sup>, in the visible region (360 nm – 780 nm), of eleven white LED sources and of an halogen lamp, by means of a Minolta CL-500A spectrophotometer, defining also the Correlated Colour Temperature (CCT) and the Colour Rendering Index (CRI) values. In a second step, we rendered the samples' hyperspectral image for the 12 different light sources, using a hyperspectral imager developed by INRIM [21, 22] calculating also the  $\Delta E_{00}$  (between each sample and the respective reference) in order to evaluate differences, in colour appearance, there would be among the integration and the original parts under these different kinds of illumination.

Concerning the light sources, referring to incandescent light as most commonly used in museum lighting, we considered only dichromatic white LED technology (Blue LED with coating of yellow phosphors) since this luminescence method at lower CCT provides a full spectrum distribution similar to halogen lamps. Nine LED products mounted the newest “cold phosphor” technology whilst two LEDs mounted the “phosphor on chip” technology. Focusing on CCT, six “Warm White” LEDs were chosen (hereafter called from WW-LED1 to WW-LED6) because their spectrum was designed to mimic a halogen lamp, generally considered as typical light sources in museums. The other LEDs ranged from “Neutral White” (from NW-LED1 to NW-LED 3) to “Cool White” (CW-LED1 and CW-LED2). Besides LEDs, we also employed a low-voltage Multifaceted Reflector halogen lamp, glass-covered MR16 type (WW-MR) as reference light source.

Concerning the hyperspectral imager we used, it is based on a Fabry-Perot interferometer where the spectra for each pixel, or for a selected area of pixels, are calculated by applying a Fourier transform-based algorithm on the recorded interferograms. The possibility of selecting the entire pixel area of interest is an advantage with respect to punctual analyses, because you can obtain a spectrum that represents the average spectral behavior of the surface (including the spectral reflectance factor of both the intact gold leaf and possibly the bole emerging from the holes). Each reflectance spectrum was normalized with respect to a Spectralon white reference. For each sample we calculated the  $L^*$ ,  $a^*$ ,  $b^*$  values in the 1976 CIELAB colour space through the algorithm described by the CIE [23] for the different light sources tested.

### 3. Results and observations

Comparing the *bole reference* to the drugged bole samples, by the conservator's point of view, only the bole samples drugged with the minimum pigment concentration (2% or 33%, second column in Fig. 3) resulted suitable, in terms of colour, for the intervention. In the conservation field, bole of different colours from yellowish to reddish is used and it is chosen depending on the colour of the original gold leaf to reproduce. This is why only a limited chromatic variability, in particular towards yellow tones, is accepted. For simplifying our study, we used, as mentioned, the reddish bole as reference (Fig. 3, on the bottom).

Focusing on colour differences between the *bole reference* and the acceptable drugged bole samples (Tab. 1), the two highest values ( $\Delta E_{00}= 8.9$  and  $\Delta E_{00}= 8.5$ )

---

<sup>4</sup> SPD curves are provided with 1 nm spectral resolution.

were recorded only for the yellow samples (CY 2% and IY 2% respectively) due to higher  $\Delta b^*$  values, while for all the other mixtures the maximum  $\Delta E_{00}$  was 4.4. These chromatic variability thresholds, higher for the yellower samples (since they are suitable for substituting the yellowish bole) and lower for the other hues, can be useful for planning future mixtures and tests.

Tab. 1 – Colour differences ( $\Delta E_{00}$ ) between the acceptable drugged bole samples and the *bole reference*.

Drugged bole samples	L*	a*	b*	$\Delta L^*$	$\Delta a^*$	$\Delta b^*$	$\Delta E_{00}$ compared to the <i>bole reference</i>
<i>bole reference</i>	49,8	16,9	9,0				
EB 2%	53,3	15,6	8,4	3,5	-1,3	-0,6	3,6
CR 2%	51,0	20,6	10,1	1,2	3,7	1,1	2,6
CY 2%	55,7	15,4	17,0	5,9	-1,5	8,0	8,5
MV 2%	48,9	18,0	7,7	-0,9	1,1	-1,3	1,6
CB 2%	49,9	12,0	4,9	0,1	-4,9	-4,1	4,2
LD 2%	47,7	17,1	8,9	-2,1	0,2	-0,1	2,1
IY 2%	52,3	18,0	22,1	2,5	1,1	13,1	8,9
WE 33%	52,6	15,8	8,6	2,8	-1,1	-0,4	2,9
DI 33%	45,8	18,0	11,9	-4,0	1,1	2,9	4,4

But how these different colours of the drugged bole actually affect the gold leaf colour appearance?

Compared to the *gilding reference*, the gilded samples show in general high colour differences that vary with irregular trends while varying the concentration values of the drugging pigment in the bole-based mixture (Tab. 2).

Tab. 2 – Colour differences ( $\Delta E_{00}$ ) between all the gilded samples and the *gilding reference*.

Gilded samples with drugged bolo	$\Delta E_{00}$ compared to the <i>gilding reference</i>						
	2%	5%	10%	15%	20%	25%	33%
EB	27,4	16,9	23,5	18,1	17,6	17,0	
CR	17,1	15,2	22,7	30,4	26,4	20,8	
CY	19,9	17,4	21,5	12,0	16,1	14,8	
MV	9,2	4,7	26,8	21,0	14,6	16,8	
CB	25,9	11,8	7,5	8,4	5,7	12,8	
LD	16,0	27,5	24,4	26,6	25,6	27,2	
IY	2,3	10,8	6,8	4,6	4,9	9,9	
WE							11,2
DI							22,2

These irregular trends seem to be not exactly due to the colour variation of the bole underneath, but rather to the holes formation in the gold leaf (Fig. 4), which is strictly connected to the pigment's granulometry.

Thus, the drugging pigment's granulometry has an important effect on the gold leaf success, so much to become a new requirement for the intervention.

During the preparation of the preliminary test samples, the problem of granulometry was evidenced in particular for the EB: anyway, after a rough grinding, a better grain size was reached and the burnishing was possible. The grain size of CY, CR and CB showed to be quite suitable. On the contrary, in particular IY and LD, but also MV (Fig. 4), DI and WE, as we bought them, showed to be unusable in terms of

granulometry, but we did not test yet the possibility of grinding them further. In these cases, the bole surface remained very uneven and made the burnishing operation particularly difficult.

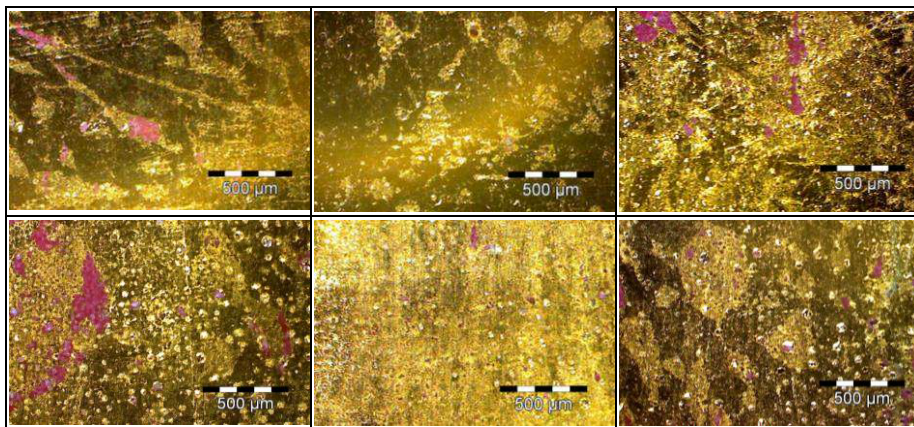

Fig. 4 – Holes formation after the burnishing of the gold leaf. Samples with bolo drugged with 2%, 5% and 10% (up), 15%, 20% and 25% (down) of MV. Video-microscopy pictures.

Concerning the recognizability tests, the gildings on bole drugged with WE and DI provided the most significant results, since the presence of those drugging pigments can be detected in UVF. Actually, WE recognizability is higher with respect to the DI and in general a simple postproduction in Adobe Photoshop (5 points increase in exposure value) could be necessary to appreciate them better (Fig. 5).

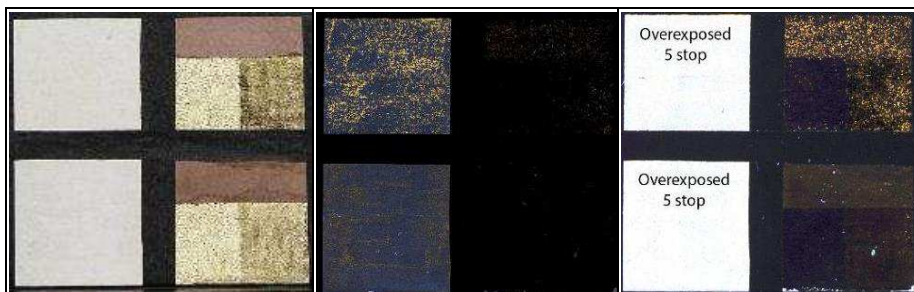

Fig.5 – WE and DI samples and respective bole mixtures with 33% in weight of WE and DI: picture in visible light, UVF in standard colour-correction mode, UVF in overexposed mode.

The use of EB, CR and CY can be detected in VIL, especially underneath a not-burnished gold leaf, as shown in Fig. 6 where for each gilded sample the left not-burnished part is different from the right burnished one. After the grinding process, the EB recognizability decreases and this can be referred once again to the granulometry: larger grain size produces bigger holes but allows a better recognizability (Fig. 2). CR and CY signal is less intense than EB, but their recognizability underneath the gold leaf can be improved in digital overexposure (Fig. 6). With respect to EB, their granulometry is finer and so more desirable.



Fig. 6 – VIL, digital overexposure. Lines of samples based on EB, CR and CY as drugging pigments.

The use of EB, CR and LD underneath the gold leaf can be highlighted in UVR: their presence at higher concentration generate a progressive reflection of the UV band, thus distinguishable from the *gilding reference* (Fig. 7).

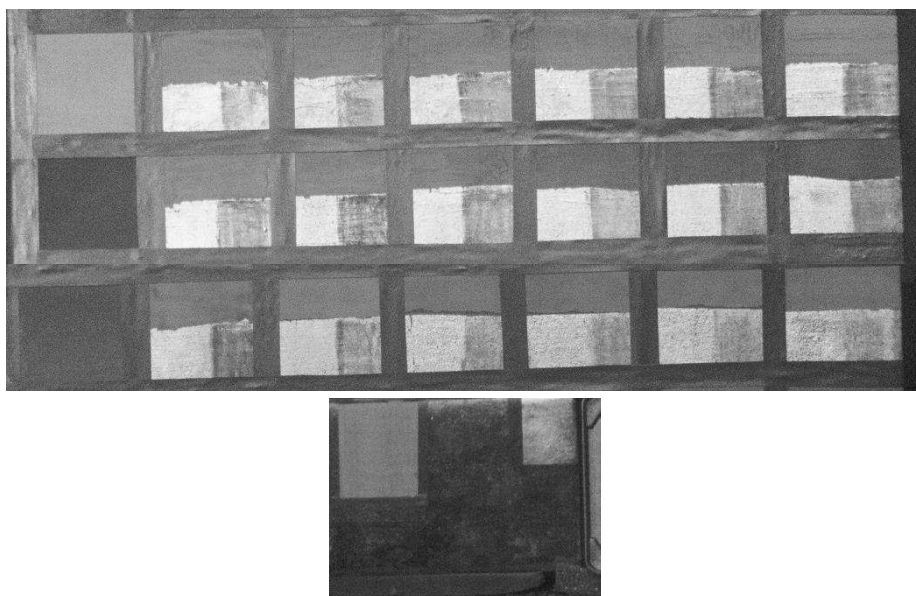

Fig. 7 – UVR. Lines of samples based on EB, CR and LD as drugging pigments, compared to the *gilding reference*.

Concerning the illumination study, Figures 8 and 9 compare spectra acquired from 12 white light sources with different colour tonality, claiming the correspondent measured CCT and CRI values in Table 3. In order to compare SPD curves and to enhance differences, each curve is normalized at its maximum energy peak, obtaining the Relative Spectral Power Distribution (RSPD).

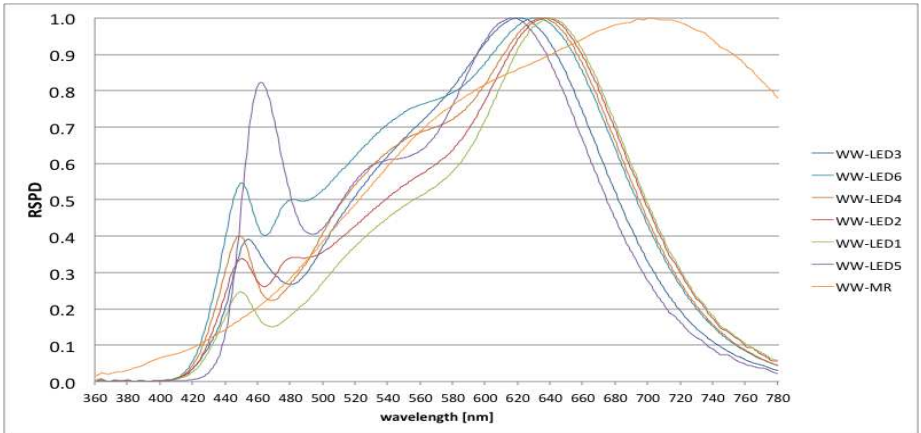

Fig. 8 – Relative Spectral Power Distribution of the selected light sources with Warm White colour tonality.

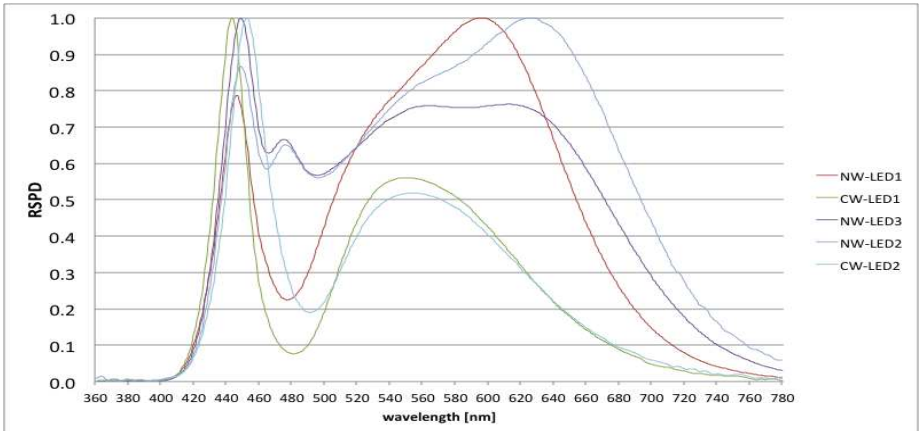

Fig. 9 – Relative Spectral Power Distribution of the selected light sources with Neutral White and Cool White colour tonality.

Tab. 3 – Measured values of CCT and CRI of the selected light sources.

Light source	WW-LED1	WW-LED2	WW-LED3	WW-LED4	WW-LED5	WW-LED6	NW-LED1	NW-LED2	NW-LED3	CW-LED1	CW-LED2	WW-MR
CCT [K]	2580	2857	3025	3130	3375	3533	3758	3894	4861	5806	6979	3012
CRI	97	96	92	97	91	99	81	97	96	68	79	98

As mentioned before, these emission spectra and the hyperspectral data of samples were used for calculating  $L^*$ ,  $a^*$ ,  $b^*$  values of each sample through the algorithm of CIELAB 1976 colour space described by the CIE [23]. This allowed to calculate the colour differences among the samples and the gilding reference under the different light sources (Tab. 4), and also to render the image of the samples (Fig. 10) providing a sort of visualization<sup>5</sup> of colour differences due to those lamps.

<sup>5</sup> Obviously, other affecting factors as the monitor's colour-correction or the colour printing process would have to be considered for a correct visual evaluation.

Tab. 4 – Colour differences ( $\Delta E_{00}$ ) among some gilded samples and the *gilding reference* calculated for LED sources with different CCT.

SAMPLE	WW-LED1					NW-LED2					CW-LED2				
	L*	a*	b*	$\Delta C^*$	$\Delta E_{00}$	L*	a*	b*	$\Delta C^*$	$\Delta E_{00}$	L*	a*	b*	$\Delta C^*$	$\Delta E_{00}$
<i>gilding ref.</i>	44,3	6,2	14,3			44,3	6,6	14,2			43,3	2,3	12,7		
MV 2%	35,4	7,3	20,6	6,4	8,6	35,5	7,8	20,6	6,5	8,6	34,2	2,1	19,3	6,4	8,8
CB 2%	56,7	10,4	34,5	20,6	15,8	56,7	11,0	34,9	21,2	15,9	54,9	2,4	32,5	18,6	15,2
LD 2%	53,3	9,2	32,9	18,9	12,8	53,3	9,8	32,9	19,0	12,9	51,6	1,4	31,7	18,1	12,7
IY 2%	48,2	9,8	32,0	18,0	9,6	48,2	10,3	32,1	18,3	9,7	46,5	2,1	31,1	17,3	9,9
WE 33%	64,2	11,8	28,9	15,7	20,6	64,3	12,4	29,1	16,1	20,7	62,2	4,1	27,0	12,9	20,0
DI 33%	74,6	10,6	29,3	15,6	27,9	74,6	11,2	29,5	16,0	28,0	72,8	2,6	27,5	13,7	27,8

In general, we observed (fig. 11) that, under the different light sources, the colour differences among the *gilding reference* and gilded samples were higher when DI, WE and CB are used as drugging pigments (2% of concentration), while the colour differences were lower with MV, IY and LD. As mentioned before, results collected until now refer to gold leaves not intact, because of drugging pigment granulometry causing the presence of holes deeply affecting the final colour. Anyway, the actual illumination in a exhibit has to be previously evaluated especially for gilded artworks, and when we choose the drugging pigment for the integration intervention.

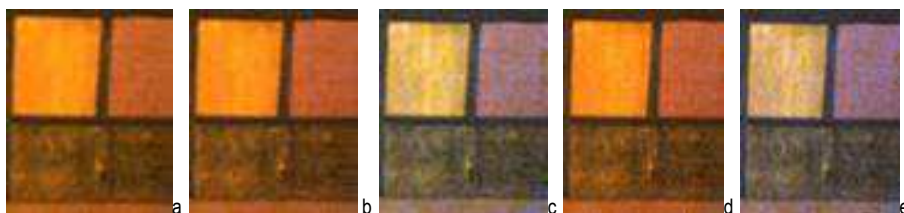

Fig. 10 RGB images of *gilding and bole references* obtained from the calculated hypercube and rendered with different light sources (a: WW-MR; b: WW-LED1; c: WW-LED3; d: WW-LED6; e: CW-LED2).

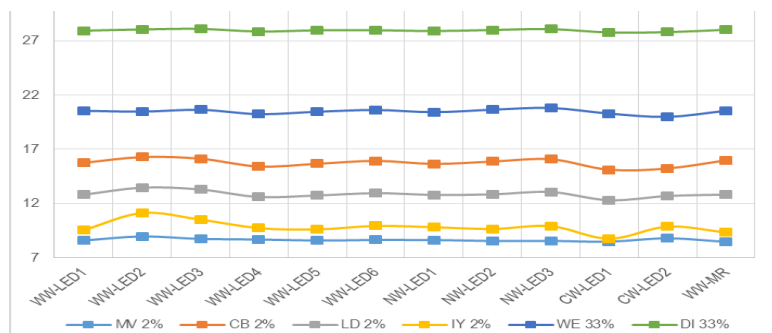

Fig. 11 – Colour differences ( $\Delta E_{00}$ ) among some samples and the *gilding reference* calculated for all the selected light sources.

## 5. Conclusions

According to the modern concept of conservation, integration of *lacunae* on the gold leaf gilding, made according to the ancient *guazzo* technique, presents practical and conceptual difficulties, as it has to present a very peculiar artistic technique (a metal foil applied on a bole layer), being in the meantime recognizable, re-tractable and aesthetic.

Many proposals about integration techniques have spontaneously risen during the last years, indicating for instance the use of watercolours, instead of the *guazzo* technique, to guarantee the recognizability, but the result does not satisfy completely the aesthetic requirement.

Our study aimed to modify the ancient recipe of the *guazzo*, the only technique allowing so brilliant gildings, by adding drugging pigments in the bole layer, suitable to be recognized with imaging and possibly low-cost techniques.

Among 50 samples made by varying the drugging pigment concentration (9 pigments were experimented), only the lowest concentration (2% in the cases of Egyptian blue, cadmium red, cadmium yellow, manganese violet, cobalt blue, lac dye and Indian yellow; 33% for wernerite and diopside) was considered chromatically suitable, since the colour of the underneath bole affects the final colour appearance of the gold leaf.

In terms of recognizability, the presence of wernerite and diopside underneath the burnished gold leaf can be detected in UVF; Egyptian blue, cadmium red and cadmium yellow can be detected in VIL sometimes resorting to a digital overexposure. Finally, the use of Egyptian blue, cadmium red and lac dye can be highlighted in UVR.

But this study highlighted also an important aspect that has to be taken into account for evaluating the recognizability: the granulometry of the drugging pigment. Until now we saw that the cadmium-based pigments are characterized by a finer and so more desirable granulometry, with respect to the Egyptian blue or the lac dye. We will focus therefore on the grain size aspect studying the best grinding process for the best drugging pigments. In the case of lac dye, for instance, we will make some tests by using only the dyeing agent, excluding the mineral filler. By means of hyperspectral and colorimetric analyses, once obtained a perfect and intact gold leaf, it will be possible to evaluate more precisely the colour differences between the integration and the original gilding, considering also the illumination condition of the exhibition space.

Basing on the results collected until now, in order to guarantee the aesthetic requirement further tests will be carried out on samples made with the suitable drugging pigment in concentrations from 0% to 2%. Finally, we will test the possibility of guarantee the recognizability of the intervention even in the layers underneath, such as adding bismuth oxide in the plaster layer, basing on the outcomes of our previous experimentation on wooden furniture.

## References

- [1] Gaius Secundus Plinius, *Naturalis Historia*, lib. XXXIII, trad. E note di A. corso, R. Mugellese, G. rosati, Ed. Einaudi, Torino, 1988.
- [2] W. Theobald, *Technik des Kunsthandwerks* im 10. Jh. Des T. *Schedula Diversarum Artium*, Berlin, 1981.

- [3] C. Cennini, *Il libro dell'arte*, a cura di Fabio Frezzato. - 5. Ed. Vicenza, Neri Pozza, 2009.
- [4] I. Crina Anca Sandu, M. Helena de Sa', M. Costa Pereira, *Ancient 'gilded' art objects from European cultural heritage: A review on different scales of characterization*, Published online in Wiley Online Library, 23\12\2010.
- [5] A Bailão, S Šustic E-Conservation Journal 2, pp. 35-44, 2012.
- [6] I. Crina Anca Sandu, M. Helena de Sa', T. Busani, *The surface behavior of gilding layer imitations on polychrome artefacts of cultural heritage*, Published online in Wiley Online Library, 6\5\2011.
- [7] D. Floreal, A. Mounier, *Multidisciplinary Conservation: a Holistic View for Historic Interiors*, Joint Interim-Meeting of five ICOM-CC Working Groups, Rome 2010.
- [8] I.C.A. Sandu, E. Murta, E. R. Neves, M.F.C. Pereira, A. V. Sandu, S. Kuckova, A. Mauricio, A comparative interdisciplinary study of gilding techniques and materials in two Portuguese Baroque "talha dourada" complexes, Estudos de conservacao e restauro n.4
- [9] C. Brandi, *Teoria del restauro*, Piccola Biblioteca Einaudi, Torino, p. 74, 1977.
- [10] U. Baldini, *Teoria del restauro*, vol. I e II, Nardini Editore, Firenze, 1978 e 1981.
- [11] M. Ciatti, *Problemi di restauro. Riflessioni e ricerche*. Edifir editore, Firenze, 1999.
- [12] B. Salimnejad, *Formulating Gesso Fills with Bismuth Oxide for discrimination by X-radiography*, WAG Postprints, Minneapolis, Minnesota, 2005.
- [13] J. Cupitt, J. Dyer, G. Verri, *Multispectral Imaging in Reflectance and Photo-induced Luminescence modes: A User Manual*, Charisma Project, British Museum, London, 2013.
- [14] D. Saunders, G. Verri, *Xenon flash for reflectance and luminescence (multispectral) imaging in cultural heritage applications*, The British Museum Technical Bulletin, 8 2014, pp.83-92.
- [15] D. Saunders, G. Verri, J. Ambers and T. Sweek, *Digital mapping of Egyptian blue: conservation implications*, Conservation and the Eastern Mediterranean: Contributions to the 2010 IIC Congress, Istanbul 2010, 220-224.
- [16] G. Accorsi, G. Verri, M. Bolognesi, N. Armaroli, C. Clementi, C. Miliani, A. Romani, *The exceptional near-infrared luminescence properties of cuprorivaite (Egyptian blue)*, Royal Society of Chemistry, Chem. Comm. 3392-3394, 2009.
- [17] G. Verri, *The use and distribution of Egyptian blue: a study by visible-induced luminescence imaging*, in *The Nebamun Wall Paintings: Conservation, Scientific Analysis and Display at the British Museum*, ISBN: 9781904982142, 2008.
- [18] T. Cavaleri, P. Buscaglia, M. Cardinali, M. Nervo, M. Pisani, P. Triolo, *Multi and hyperspectral imaging and 3D techniques for discovering Egyptian coffins*, Book of abstract of the Conference Ancient Egyptian coffins: Past Present Future, Cambridge, 7-9 April 2016.
- [19] S. Dumazet, A. Genty, A. Zymla, F-X. de Contencin, A. Texier, N. Ruscassier, B. Bonnet, P. Callet, *Influence of the substrate colour on the visual apperarence of gilded sculpture*, XXI International CIPA Symposium, 01-06 October, Athens, Greece, 2007.
- [20] C. Oleari, *Misurare il colore*, Hoepli, pp. 222-224, 2008.
- [21] [http://www.inrim.it/res/hyperspectral\\_imaging/](http://www.inrim.it/res/hyperspectral_imaging/)
- [22] M. Zucco, V. Caricato, A. Egidi, M. Pisani, *A Hyperspectral Camera in the UVA Band, Instrumentation and Measurement*, IEEE Transactions on 64 (6), 1425-1430, 2015.
- [23] CIE 15:2004. Technical Report: Colourimetry, 3rd edition.



# Diagnostic study on original stamps of the Kingdom of Sardinia

<sup>1</sup>Tiziana Cavaleri, <sup>2</sup>Alberto Conte, <sup>1</sup>Anna Piccirillo

<sup>1</sup> Fondazione Centro per la Conservazione e il Restauro *La Venaria Reale*,  
tiziana.cavaleri@centrorestaurovenaria.it, anna.piccirillo@centrorestaurovenaria.it

<sup>2</sup> Accademia delle Scienze di Torino and Università degli Studi di Torino, alberto.conte@unito.it

## 1. Introduction

As philatelists know, the early 19<sup>th</sup> century stamps show many different shades of colours. Besides conservative problems as environmental colour changes, one of the main reasons of that was the difficulty, for the printers, to prepare the same kind of ink at every subsequent printing.

Since for the very first stamp of the world, the celebrated Queen Victoria's *1d Penny Black* of Great Britain issued on 6 May 1840, the "Stanley Gibbons Catalogue" [1] shows three shades: *intense black*, *black* and *grey-black*. For the red *1 franc* of the first French issue (1849) – also called "Cerès" – the "Yvert Tellier Catalogue" [2] gives nine shades: *carmin foncé*, *carmin clair*, *carmin cerise*, *rouge-brun*, *carmin-brun*, *vermillon*, *vermillon vif*, *vermillon terne*, *vermillon pale* (*Vervelle*). Most famous for its variety of shades is the Kingdom of Sardinia's fourth issue (1855-1863): for the *10 cents* the "Catalogo Sassone" [3] gives fifty (!) different shades, whose fancy names, given historically by the philatelists, go from *yellowish umber earth* to *deep olive greenish grey*, up to *very-dark chocolate brown*.

Actually, it is often very difficult to classify the various stamps' shades and the philatelic experts can do it only by comparison with well-known specimens. Moreover, the commercial value of the various shades of the same stamp can vary considerably; for instance, the *1 franc* previously mentioned, "Cerès" of the type *vermillon vif* is the greatest rarity of the French philately, whilst the *carmin foncé* is worth 1/10 of it.

At the scientific laboratories of the "Centro per la Conservazione e il Restauro *La Venaria Reale*", starting from the possibility of using noninvasive diagnostic techniques [4], we studied some stamps of the second issue of Sardinia (1 October 1853) which is a very peculiar issue since stamps are not printed on white paper, but embossed on tinted wove paper.

By means of fiber optic reflectance spectroscopy (FORS), Fourier transform infrared spectroscopy (FT-IR) in reflection mode and X-ray fluorescence (XRF) analyses we studied the tinted wove paper's chemical composition of the three values: *5 cents* green, *20 cents* blue, *40 cents* pink. Moreover, considering that the last one is classified in the "Catalogo Sassone" in three different shades, *light rose* (number 6), *rose* (number 6a) and *bright rose* (number 6b), we carried out colorimetric analyses in the CIELAB system, suitable for evaluating objectively the homogeneity among samples of the same shade, and for calculating colour differences ( $\Delta E_{00}$ ) through the CIEDE2000 formula. The possible *40 cents*' shade discrimination on the basis of scientific analyses may arouse interest, as it is estimated that only 25000-35000 pieces were produced in the history; moreover, the commercial values ratio (of stamps used on letters) is 6: 6a: 6b = 1: 2: 4, the *light rose* (number 6) being the most common one and the *bright rose* (number 6b) the rarest.

## 2. Materials and methods

The set of selected samples consists of fifteen stamps (of about 4.8 cm per 3 cm), here called with letters for simplifying the data discussion. A and B refer to a 5 cents green stamp and to a 20 cents blue one, respectively (fig. 1). The others samples (fig. 1-2, samples from C to Q) are 40 cents stamps. In particular, C, D and E were evaluated as *light rose* shade (number 6 in “Catalogo Sassone”); F, G and H were attributed to the *rose* shade (number 6a); I, L, M, N, O and P were assessed as *bright rose* shade (number 6b). Only the Q sample is “unknown” thus its worth has not been yet evaluated. Samples A, B, C and F are mint (unused) stamps, all the other samples are used (some on fragment or on cover): unfortunately, we could not have at our disposal any mint *bright rose*, which is extremely scarce and almost impossible to find.

As mentioned, all samples belong to the second issue of Sardinia (1 October 1853), this very peculiar issue since stamps are not printed on white paper, but embossed on tinted wove paper. The study about materials, linked to technological aspects of the historical stamps production, was carried out on samples reported in figure 1 by means of different noninvasive analysis: fiber optics reflectance spectroscopy (FORS), X-ray fluorescence (XRF), optical microscopy in visible light and UV fluorescence (Vis-UV OM) and Fourier transform infrared spectroscopy (FT-IR).



Fig. 1 – Stamps of the second issue of Sardinia (1 October 1853): 5 cents green (sample A), 20 cents blue (B) and 40 cents examples of the *light rose* shade (C), of the *rose* shade (F) and of the *bright rose* shade (I).

On all the 40 cents samples (samples from C to Q) we also made colorimetric analyses (COL) in order to evaluate and possibly to verify by an objective point of view the belonging of each stamp to its proper, declared shade.

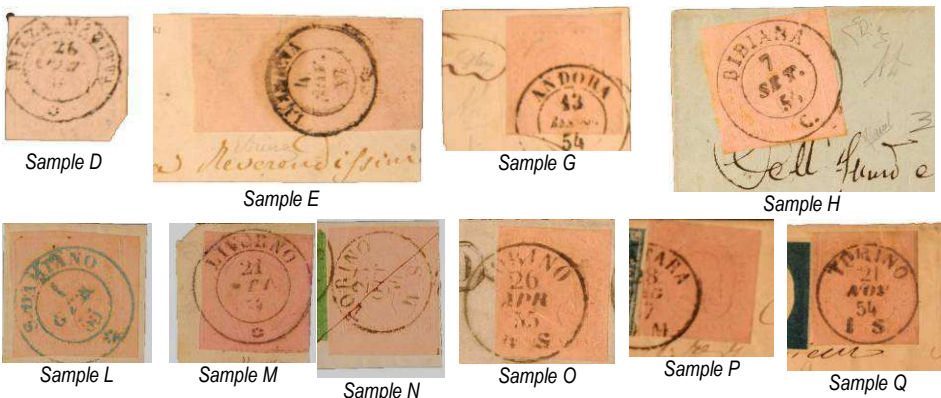

Fig. 2 – Stamps of the second issue of Sardinia (1 October 1853): other 40 cents examples of the *light rose* shade (D, E), of the *rose* shade (G, H) and of the *bright rose* shade (L, M, N, O and P) and *unknown* shade (Q).

Finally, we tried to define the proper shade of the *unknown* sample basing on the outcomes of the different scientific analyses.

Concerning the instrumentations, FORS analyses were performed by means of an Ocean Optics HR2000+ES spectrophotometer and an Ocean Optics HL2000 halogen lamp, bounded by optical fibres of 400  $\mu\text{m}$  in diameter, working in a  $2\times 45^\circ/0^\circ$  geometry and collecting spectra along a 350 nm to 1000 nm wavelength range with a 0,5 step resolution.

XRF analyses were carried out by means of a portable Micro-EDXRF Bruker ARTAX 200 spectrometer equipped with a fine focus X-ray source, a Molybdenum anode, a 4096 channels ADC and a spot of variable dimensions from 0.65 mm to 1.50 mm. We worked with anodic voltage 30 kV, anodic current 1300  $\mu\text{A}$ , purging helium in order to improve the detecting threshold (minimum detectable atomic number: 11, sodium).

Samples were observed through a OLYMPUS BX51 microscope connected to a PC by means of a digital OLYMPUS DP71 camera using its analySIS Five software, both illuminating with visible light and UV radiation.

FT-IR analyses were performed in reflection mode by means of a FT-IR Bruker Vertex 70 spectrophotometer coupled with a Bruker Hyperion 3000 infrared microscope. Only on a small fragment of a *light rose* shade stamp (not present in the list of figg. 1 and 2), the analyses were carried out in transmission mode by means of FT-IR microscope with a micro-ATR objective.

Colorimetric analyses were carried out through a spectrophotometer Konica Minolta CM700d that works in a  $d/8^\circ$  optical geometry along a 400 nm to 700 nm wavelength range, with a 10 nm step resolution. The instrument was set to provide CIELAB 1976 ( $L^*$ ,  $a^*$ ,  $b^*$ ,  $C_{ab}^*$ ) chromatic coordinates, where  $L^*$  corresponds to lightness,  $a^*$  from negative to positive corresponds respectively to the green or red component and  $b^*$  from negative to positive corresponds respectively to the blue or yellow component, for standard illuminant  $D_{65}$ . We acquired three measurements on each sample (table 2): average  $L^*$ ,  $a^*$  and  $b^*$  values and uncertainty were used to evaluate the colour homogeneity within the single sample and among samples declared of the same shade. Through the CIEDE2000 formula [5, 6] we also measured the colour differences ( $\Delta E_{00}$ ) among samples of the same shade in order to quantify the colour difference threshold accepted by the philatelic experts. The colorimetric values of the *unknown* sample (sample Q) were finally used to compare it to the different shades in order to possibly attribute it to a specific one.

### 3. Results

Outcomes of the FT-IR, XRF and FORS analyses revealed the chemical composition of the coloring materials on the stamps coming from the second issue of the Kingdom of Sardinia (1 October 1853).

In particular, the wove paper of the 20 cents blue stamp (sample B) proved to be dyed with Prussian blue, a synthetic dark blue pigment made of ferric ferrocyanide and whose receipt has been known since the very beginning of the 18<sup>th</sup> century [7, 8, 9, 10]. In the FT-IR spectrum (fig. 3), in fact, the band at about  $2100\text{ cm}^{-1}$  is due to the ferric ferrocyanide. The presence of Prussian blue is also suggested by the XRF

counts of iron (table 1). Also the absorption band at about 680 nm in the FORS spectrum (fig. 4) has to be referred to the charge transfer transition from Fe(II) of the ferrocyanide anion to the Fe(III) cation [11, 12] in the Prussian blue pigment molecule.

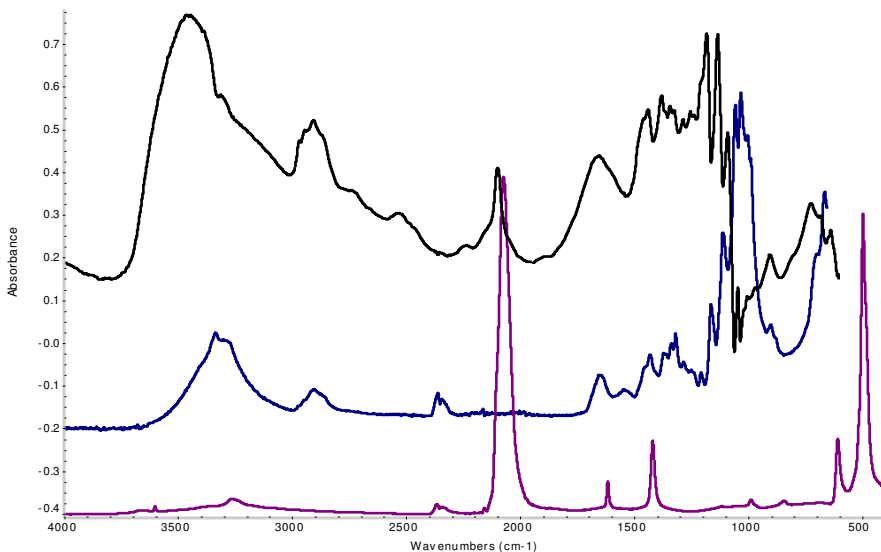

Fig. 3 – FT-IR spectrum in reflection mode of sample B, the 20 cents blue stamp of the second issue of Sardinia (black line), compared to the reference spectrum of the paper in transmission mode (blue line) and to the reference of Prussian blue in transmission mode (purple line).

Tab. 1 – Results of the XRF analyses.

Main chemical elements XRF [counts per second]													
SAMPLE NAME	Al	Si	P	S	Cl	K	Ca	Cr	Mn	Fe	Cu	Zn	Pb
Sample A (green)_meas1	1	1		4	1	1	2	4	1	6			8
Sample A (green)_meas2				4	1	1	4	4	2	7	1	1	9
Sample B (blue)_meas1	1			2		1	2	1	1	8	1	1	1
Sample B (blue)_meas2	1	1		2	1	1	2	1	1	9	2	1	1
Sample C (light rose)_meas1	1	1		2		1	7			2	1	5	
Sample C (light rose)_meas2		1		3		1	9			3	1	7	1
Sample G (rose)_meas1				5	3	3	10			3	1	1	
Sample G (rose)_meas2	1	1		3	2	3	8			2	1	1	
Sample G(paper)_meas1	1	1	1	3	1	1	4		2	2	1		
Sample G(paper)_meas2	1	1		3	1	1	4		1	2	1	1	
Sample I (bright rose)_meas1	1	1		3	1	2	9		1	3	1	1	
Sample I (bright rose)_meas2	1	1		3	1	2	11		1	3	1	1	
Sample Q (paper)_meas1	1	1	1	4	2	3	9		2	8	2	2	2
Sample Q (paper)_meas2	1	1	1	4	5	2	9		2	6	2	2	
Sample Q (unknown)_meas1		1		2	1	1	2	1		6	2	1	1
Sample Q (unknown)_meas2		1			1	2	4	1		6	1	2	1

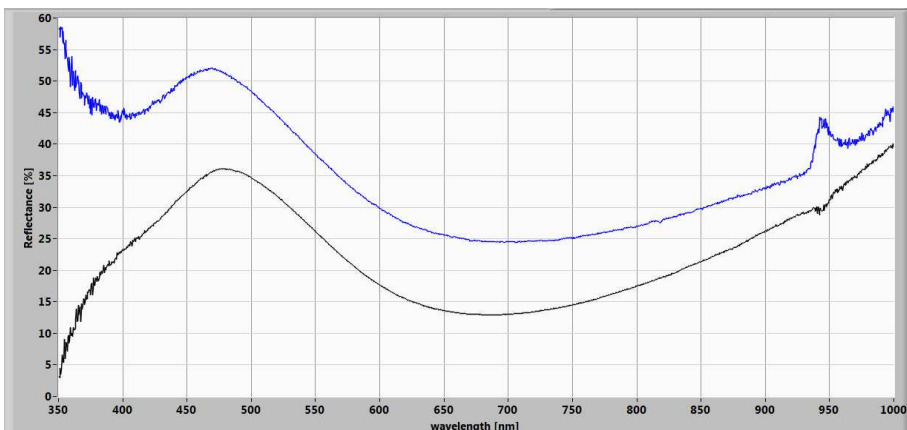

Fig. 4 – FORS spectrum of sample B, the 20 cents blue stamp of the second issue of Sardinia (black line), compared to the reference spectrum of a Prussian blue paint layer (blue line).

In the 5 cents green stamp (sample A) the FT-IR and FORS spectra (fig. 5-6) revealed the presence of Prussian blue, while the XRF analysis showed, beyond the iron signal, the presence of lead and chrome (tab. 1) which suggest the use of yellow lead chromate, possibly added to the Prussian blue in order to get the green colour [13].

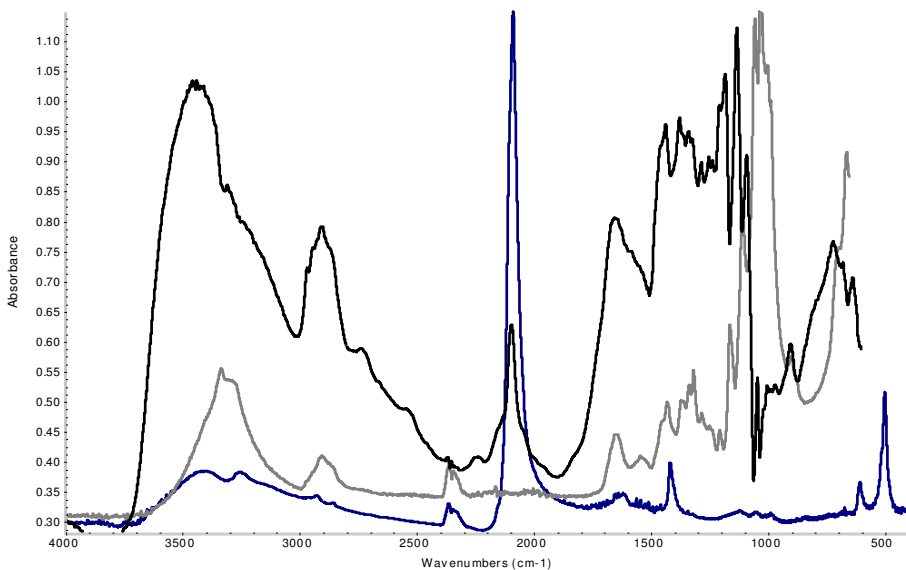

Fig. 5 – FT-IR spectrum in reflection mode of sample A, the 5 cents green stamp of the second issue of Sardinia (black line), compared to the reference spectrum of the paper in transmission mode (grey line) and to the reference of Prussian blue in transmission mode (blue line).

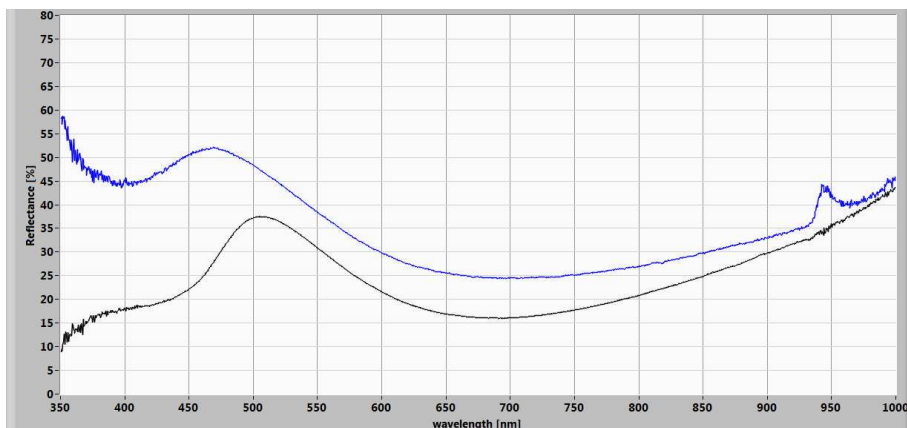

Fig. 6 – FORS spectrum of *sample A*, the 5 cents green stamp of the second issue of Sardinia (black line), compared to the reference spectrum of a Prussian blue paint layer (blue line). The absorption band between 350 nm and 450 nm suggests the presence of a yellow pigment or dye in the mixture.

Concerning the pink 40 cents stamps (samples from C to Q), FT-IR analyses showed few differences among the different samples, most likely due to technical difficulties in acquiring FTIR spectra of opaque samples in reflection modality. Figure 7 shows the FTIR spectra of the C, F and M samples, one per shade. Peaks at around 1600 and 1320  $\text{cm}^{-1}$ , more evident in sample M, have to be referred to the presence of oxalates and the bands at around 2500 and 2200  $\text{cm}^{-1}$ , more intense in samples C and M, indicate the presence of gypsum probably correlated to the paper production process. Even if the samples show the presence of small red particles inside the paper fibers (see figure 8), no FTIR peaks or flexes can be definitively referred to the dyeing agents neither can be used to discriminate the shades.

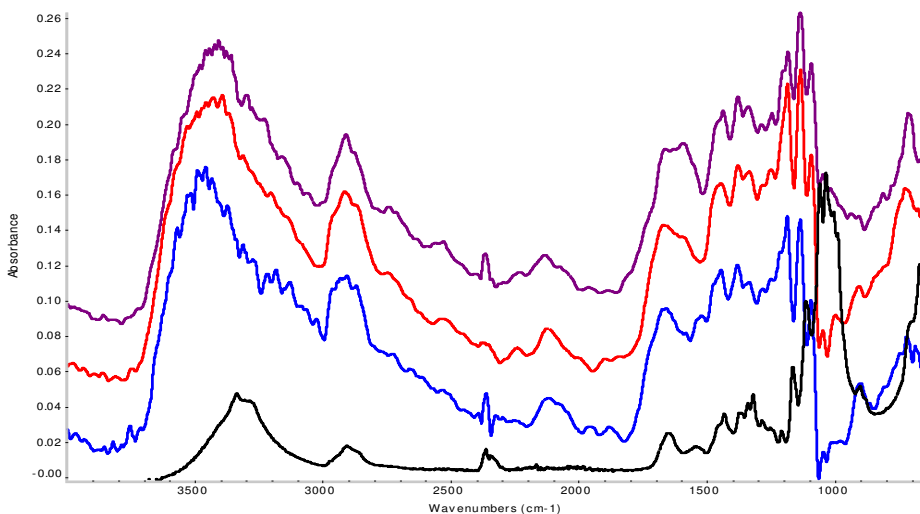
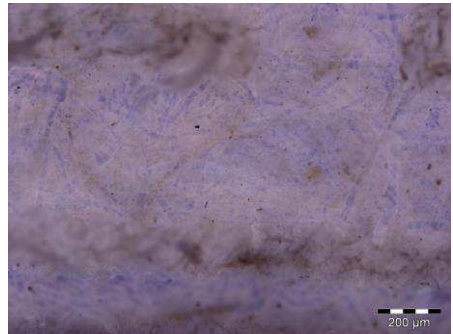
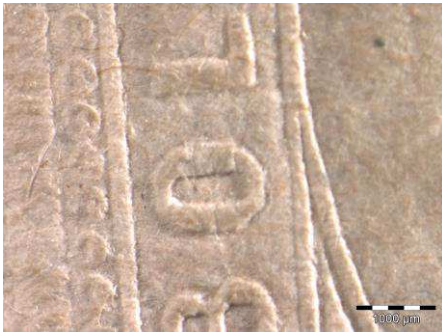
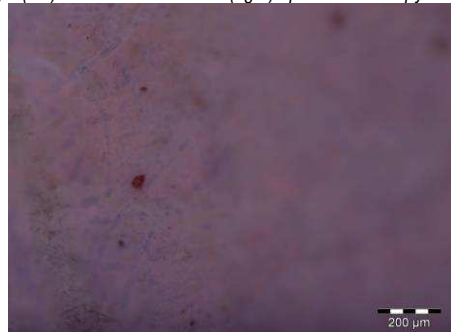

Fig. 7 – FT-IR spectra in reflection mode of the samples C (red line), F (blue line) and M (purple line) compared to the reference spectrum of the paper (black line) in transmission mode.



Picture details of sample C (*light rose shade*) in visible light (left) and UV fluorescence (right) optical microscopy.



Picture details of sample F (*rose shade*) in visible light (left) and UV fluorescence (right) optical microscopy.

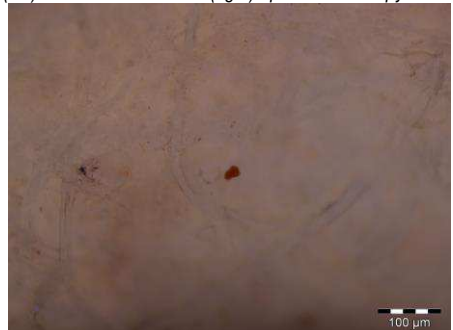
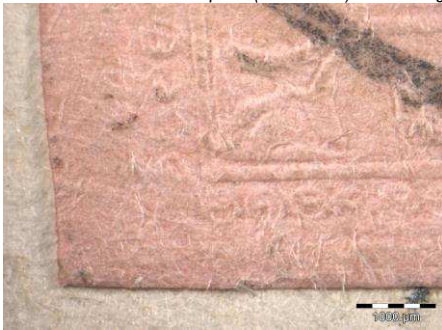

Picture details of sample M (*bright rose shade*) in visible light (left) and UV fluorescence (right) optical microscopy.

Fig. 8 – Pictures details of some significant samples in optical microscopy.

Finally, XRF and FORS analyses indicate some differences in chemical composition between the *light rose* stamp (sample C) and the other two shades (sample F, *rose*, and sample M, *bright rose*). In particular, FORS spectra show the different spectral behavior of sample C, *light rose*, with respect to the other two where absorption bands are more evident (fig. 9) and similar one each other. XRF analyses highlight also that the *light rose* shade contains a significant white component probably zinc white (see zinc XRF counts in table 1), while no signal can be definitively attributed to a red coloring agent.

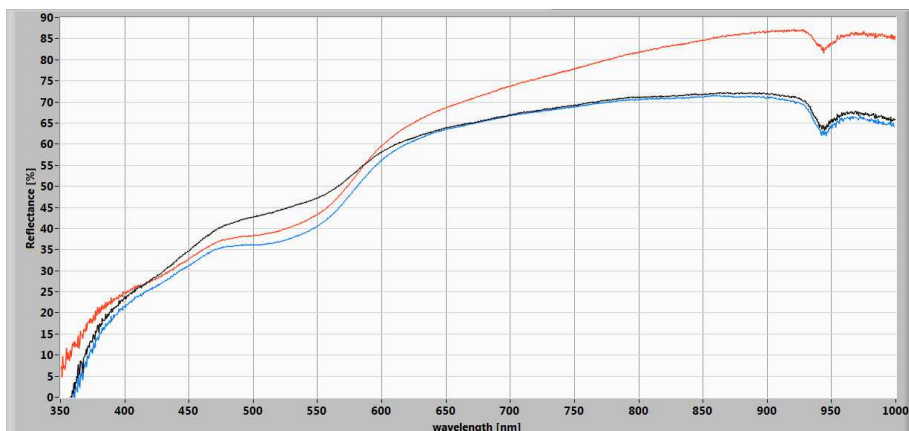

Fig. 9 – FORS spectra of *samples C* (black line), *F* (blue line) and *M* (red line).

In order to characterize the red dye, basing on the literature that indicates the use of natural compounds as paper dyeing agents [13], it was possible to perform FT-IR analyses in transmission mode on a small fragment of a *light rose* shade stamp (not present in the list of fig. 1 and 2). The spectrum (fig. 10) revealed signals of organic compounds such as fatty acids or wax, and proteins, ascribable as well to the adhesive on the back of the stamp and/or to the paper additives, but also signals of the red cochineal, possibly used as dyeing agent of all the three pink shades.

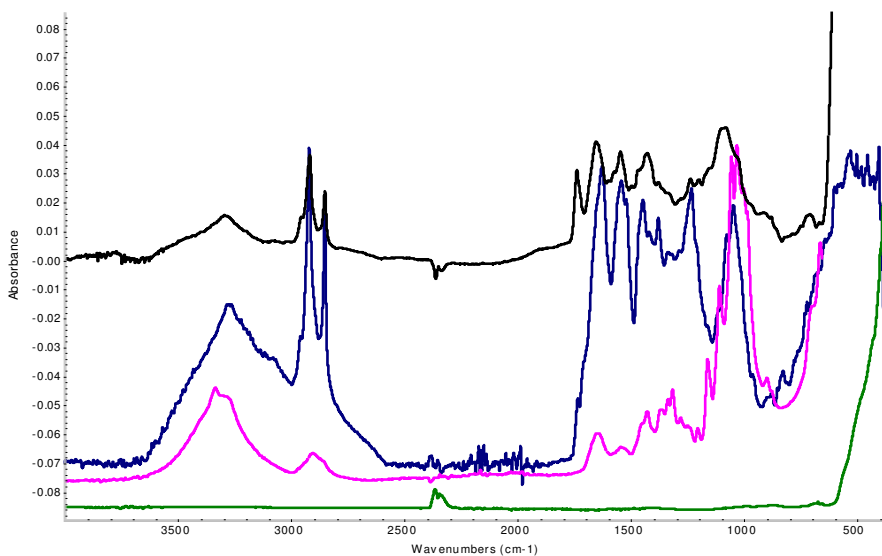

Fig. 10 – FT-IR spectrum in micro-ATR mode of the small fragment of a *light rose* shade stamp (black line) compared to the reference spectra of the red cochineal (blue line), of the paper (pink line) and of the zinc white (green line).



Colorimetric analyses performed on the *40 cents* stamps (sample from C to Q) allowed to evaluate the homogeneity of the colour within the same sample. Considering the L\*, a\* and b\* coordinates separately, the uncertainty values calculated on the average of the three measurements (table 2) go from 0.13 (among the a\* values of sample Q) up to 2.23 (among the b\* values of sample H), thus indicating a non-perfect uniformity. Differently from what we could think, we observed that the mint (unused) samples are not always more homogeneous.

Considering instead the colorimetric homogeneity within the same shade (see table 2, yellow rows), by measuring the uncertainty on the average of all the measurements, we saw that the uncertainty values go from 1.25 (among the a\* values of the *bright rose* shade) to 3.63 (among the b\* values of the *rose* shade), indicating another time a certain variability. Samples of the same shade show indeed a perceptible colour difference between each other (table 3), reaching a maximum  $\Delta E_{00}$  value of 5.8 among the *rose* samples (F, G, H), the highest one obtained between the unused stamp and the used ones. Among the *bright rose* samples (I, L, M, N, O, P) it goes up to 3.8.

These results made the attempt of attributing the *unknown* sample to its proper shade very difficult.

Actually, the differences are well understandable considering the many causes that can affect the colour of a stamp during time, in different and obviously not controlled environmental conditions, but also in their process of printing and production, about which we unluckily have very few information.

For these reasons, we carried out both compositional analyses and colorimetric measurements on the *unknown* sample and on the attributed ones, in order to obtain useful comparisons.

First, the XRF analyses (table 1) confirmed the absence of zinc white in the *unknown* sample, allowing to exclude its belonging to the *light rose* shade.

Secondly, FORS analyses showed the *unknown* sample's spectral behavior very similar to the *bright rose* shade's one (fig. 11).

Finally, colorimetric analyses carried out on the *unknown* sample (table 4) showed a good correspondence in both L\* and a\* coordinates with respect to the *bright rose* shade values. As we are considering pink samples, it may be that L\* (lightness) and a\* (red component) have to be considered more effective for the attribution, whereas the b\* variability could be mainly linked to the common yellowing of the paper. The graph in figure 12 shows the uncertainty average values calculated from the three measurements on the *unknown* sample, compared to average and the uncertainty values of the *rose* and *bright rose* shade (the *light rose* excluded from the XRF outcomes).

Moreover, if compared to each one of the selected samples (table 3), the *unknown* sample shows the lowest  $\Delta E_{00}$  value (1.42) with respect to the sample L, belonging to the *bright rose* shade.

Tab. 2 – CIELAB 1976 coordinates of the 40 cents samples (three measurements on each one) and average values.

	SAMPLE NAME AND NUMBER	CIELAB 1976 CHROMATIC COORDINATES			
		L*(D <sub>65</sub> )	a*(D <sub>65</sub> )	b*(D <sub>65</sub> )	
light rose (number 6)	Sample C, unused	Meas1	74,47	7,06	12,23
		Meas2	74,9	4,47	12,03
		Meas3	74,85	4,95	11,9
		<b>Average</b>	<b>74,74 ± 0,24</b>	<b>5,49 ± 1,38</b>	<b>12,05 ± 0,17</b>
	Sample D, used	Meas1	78,75	5,39	10,79
		Meas2	76,24	4	9,22
		Meas3	76,08	4,02	9,59
		<b>Average</b>	<b>77,02 ± 1,5</b>	<b>4,47 ± 0,8</b>	<b>9,87 ± 0,82</b>
	Sample E, used, on fragment (Luserna)	Meas1	77,05	7,1	14,68
		Meas2	78,37	6,66	14,37
Meas3		76,87	6,71	14,65	
<b>Average</b>		<b>77,43 ± 0,82</b>	<b>6,82 ± 0,24</b>	<b>14,57 ± 0,17</b>	
<b>AVERAGE AND UNCERTAINTY VALUES OF THE SHADE</b>		<b>76,4 ± 1,52</b>	<b>5,6 ± 1,3</b>	<b>12,16 ± 2,08</b>	
rose (number 6a)	Sample F, unused	Meas1	74,14	8,02	10,63
		Meas2	72,66	10,27	11,3
		Meas3	72,69	9,45	10,87
		<b>Average</b>	<b>73,16 ± 0,85</b>	<b>9,25 ± 1,14</b>	<b>10,93 ± 0,34</b>
	Sample G, used, on fragment (Andora)	Meas1	75,55	8,08	18,76
		Meas2	74,04	8,73	18,71
		Meas3	76,23	8,11	18,18
		<b>Average</b>	<b>75,27 ± 1,12</b>	<b>8,31 ± 0,37</b>	<b>18,55 ± 0,32</b>
	Sample H, used, on envelope (Bibiana)	Meas1	72,26	7,04	19,04
		Meas2	72,59	7,23	16,5
Meas3		73,02	6,02	14,59	
<b>Average</b>		<b>72,62 ± 0,38</b>	<b>6,76 ± 0,65</b>	<b>16,71 ± 2,23</b>	
<b>AVERAGE AND UNCERTAINTY VALUES OF THE SHADE</b>		<b>73,69 ± 1,41</b>	<b>8,11 ± 1,28</b>	<b>15,4 ± 3,63</b>	
bright rose (number 6b)	Sample I, used	Meas1	74,78	8,94	10,03
		Meas2	74,2	8,29	9,94
		Meas3	74,68	7,36	10,34
		<b>Average</b>	<b>74,55 ± 0,31</b>	<b>8,20 ± 0,79</b>	<b>10,10 ± 0,21</b>
	Sample L, used, on fragment (san Damiano)	Meas1	75,74	9,43	13,05
		Meas2	77,05	8,43	13,89
		Meas3	75,94	9,22	13,13
		<b>Average</b>	<b>76,24 ± 0,71</b>	<b>9,03 ± 0,53</b>	<b>13,36 ± 0,46</b>
	Sample M, used, on fragment (Livorno Ferraris)	Meas1	74,33	11,35	11,58
		Meas2	75,27	10,03	14,1
		Meas3	75,14	11,11	11,82
		<b>Average</b>	<b>74,91 ± 0,51</b>	<b>10,83 ± 0,7</b>	<b>12,50 ± 1,39</b>
	Sample N, used, on fragment (with green)	Meas1	74,96	10,32	9,62
		Meas2	74,8	10,43	9,83
		Meas3	75,21	9,22	9,82
		<b>Average</b>	<b>74,99 ± 0,21</b>	<b>9,99 ± 0,67</b>	<b>9,76 ± 0,12</b>
	Sample O, used, on envelope (with 2 <sup>nd</sup> em)	Meas1	70,83	10,26	12,15
		Meas2	72,71	9,07	11,56
		Meas3	71,07	10,52	11,94
		<b>Average</b>	<b>71,54 ± 1,02</b>	<b>9,95 ± 0,77</b>	<b>11,88 ± 0,3</b>
Sample P, used, on envelope (with 4 <sup>th</sup> em)	Meas1	73,93	11,74	13,65	
	Meas2	74,91	10,8	13,2	
	Meas3	74,35	11,88	13,28	
	<b>Average</b>	<b>74,40 ± 0,49</b>	<b>11,47 ± 0,59</b>	<b>13,38 ± 0,24</b>	
<b>AVERAGE AND UNCERTAINTY VALUE OF THE SHADE</b>		<b>74,44 ± 1,55</b>	<b>9,91 ± 1,25</b>	<b>11,83 ± 1,57</b>	

Tab. 3 – Colour differences CIEDE2000 between any couple of samples (from average values of table 2).

SAMPLE NAME AND NUMBER	COLOUR DIFFERENCE CIEDE2000
<b>Light rose (number 6)</b>	
C-D	2,34
C-E	2,67
D-E	3,5
<b>Rose (number 6a)</b>	
F-G	5,83
F-H	5,55
G-H	2,5
<b>Bright rose (number 6b)</b>	
I-L	2,52
I-M	2,52
I-N	1,91
I-O	2,85
I-P	3,13
I-Q	3,32
L-M	2,28
L-N	3,26
L-O	3,85
L-P	2,68
M-N	1,87
M-O	2,63
M-P	0,76
N-O	3,02
N-P	2,5
O-P	2,55

SAMPLE NAME AND NUMBER	COLOUR DIFFERENCE CIEDE2000
<b>Compared to the unknown sample</b>	
Q-C ( <i>light rose</i> )	4,62
Q-D ( <i>light rose</i> )	6,05
Q-E ( <i>light rose</i> )	3,7
Q-F ( <i>rose</i> )	3,08
Q-G ( <i>rose</i> )	3,52
Q-H ( <i>rose</i> )	4,54
Q-I ( <i>bright rose</i> )	3,32
Q-L ( <i>bright rose</i> )	1,42
Q-M ( <i>bright rose</i> )	2,08
Q-N ( <i>bright rose</i> )	3,7
Q-O ( <i>bright rose</i> )	3,49
Q-P ( <i>bright rose</i> )	2,03

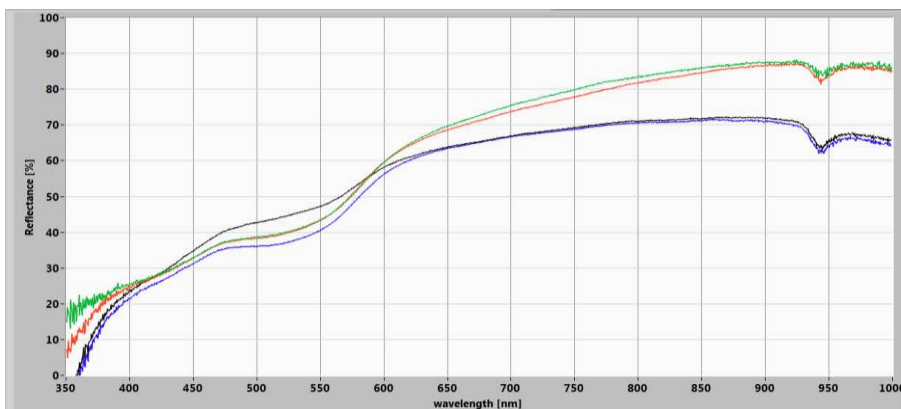

Fig. 11 – FORS spectrum of the unknown sample (green line) compared to the spectra of sample M *bright rose* shade (red line), samples C *light rose* shade (black line) and sample F *rose shade* (blue line).

Tab. 4 – CIELAB 1976 coordinates of the unknown sample.

SAMPLE NAME AND NUMBER		CIELAB 1976 CHROMATIC COORDINATES			
			L*(D <sub>65</sub> )	a*(D <sub>65</sub> )	b*(D <sub>65</sub> )
<i>unknown</i>	Sample Q, used, on letter (Paris)	meas1	74,95	10,15	14,36
		Meas2	75,23	10,37	16,36
		Meas3	75,67	10,13	14,25
		<b>Average</b>	<b>75,28 ± 0,36</b>	<b>10,22 ± 0,13</b>	<b>14,99 ± 1,19</b>

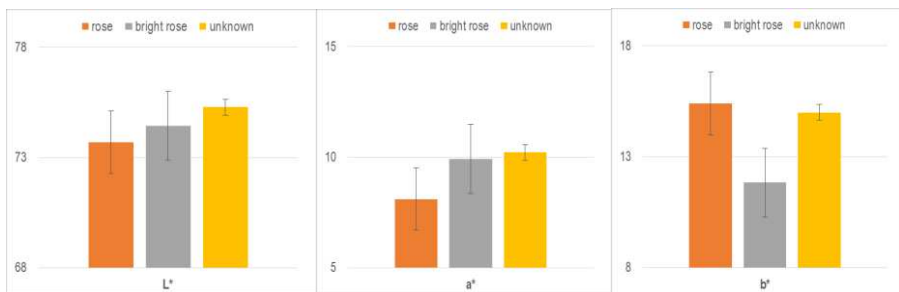

Fig. 12 – Average values and uncertainty of the *unknown* sample compared to the *rose* and the *bright rose* shades.

## 4. Conclusions

Scientific analyses allowed to confirm the presence of at least two different stamp productions belonging to the second issue of the Kingdom of Sardinia (1853).

We noticed that the use of chemical analyses is essential to support the colorimetric measurement in the stamps' shade discrimination, since the comprehension of materials goes beyond the visual appearance that could be affected by the ageing and the historical pasts of the samples. Uniqueness of the stamps required the exclusive use of noninvasive techniques thus reducing the achievable information useful for an in-depth and more effective production materials characterization.

Nevertheless, the combination of FORS, XRF, FT-IR and colorimetric analyses, couple to the optical microscopy observations, was a first attempt for the shade classification of this particular kind of stamps, that are not printed on white paper, but embossed on tinted wove paper, based on scientific, objective data.

## References

- [1] Commonwealth & British Empire Stamps 1840-1970, 118th edition 2016, STANLEY GIBBONS LTD, London and Ringwood, 2015.
- [2] *Classiques du monde 1840-1940*, YVERT & TELLIER, Amiens, 2005.
- [3] *Catalogo dei francobolli degli Antichi Stati Italiani, del Regno di Vittorio Emanuele II e del Regno d'Italia fino al 1900*, 1° volume: I Francobolli, 75° edizione 2016, SASSONE S.R.L., Milano, 2015.
- [4] David L. Herendeen et al., "Institute for Analytical Philately", Inc., 2010.
- [5] C. Oleari, "Misurare il colore", Hoepli, 2008.
- [6] R. Johnston-Feller, "Color science in the examination of Museum Objects", the Getty conservation institute, 2001.
- [7] L. Coleby, "A history of Prussian Blue", *Annals of Science*, N. 2 pp. 206-211, 1939.
- [8] Kirby, "Fading and colour change of Prussian blue: Occurrences and early reports", *National Gallery Technical Bulletin* Vol. 14, N.1, pp. 62-71, 1993.
- [9] A. Kraft, "On the discovery and history of Prussian Blue", *Bull. Hist. Chem*, Vol. 33, N. 2, pp. 61-67, 2008.
- [10] M. Ware, "Prussian blue: Artists' pigment and Chemists' Sponge", *J. of Chemical Education*, Vol. 85, N. 5, pp. 612-621, 2008.
- [11] Melvin B. Robin, "The color and electronic configurations of Prussian blue", *Inorg. Chem.*, Vol. 1, n° 2, pp 337-342, 1962.
- [12] M. Bacci, "Optical spectroscopy and colorimetry" in "Physics methods in Archeometry", *Proceedings of the International School of Physics "Enrico Fermi"*, IOS Press, 2004.
- [13] E. C Tucker et al., "The manufacture of pulp and paper, a textbook of modern pulp and paper Mill Practice", First Edition, McGraw-Hill bookcompany, inc. New York and London, chapter 5 p.2 and pp. 9-11, 1924.

## **6. COLOUR AND BUILT ENVIRONMENT**



# Colour, Shape and Pattern on New Shading Façades

<sup>1</sup>Alessandro Premier

<sup>1</sup>Dip. Politecnico di Ingegneria e Architettura, Università di Udine, alessandro.premier@uniud.it

## 1. Introduction

One of the recent outlines of the architectural design is the wide use of shading elements as tools to create shapes and patterns on a façade. In some cases the shading elements create the entire façade with a sort of 2D configuration (i.e. pixelated façades), but in other cases is the whole envelope of the building that is designed by the shading elements as in a 3D configuration. In most of these cases the shading elements are static (in the sense that they do not move), but they are shaped and repeated as to create specific patterns on the façade. The pattern design is always conceived to create a dynamic effect while the façade is obviously static, in any case not composed by moving elements.

The combination of three factors seems to be the key to understand the philosophy behind the design of these façades: shape, pattern and colour. The shape of the elements defines the character and the lines of the building envelope. The repetition of them, the pattern gives rhythm to the façade [1]. Colour seems to be the element that allows the friction between the different components of the façade, vibrating it.

The three different factors can obviously produce different effects. In the 2D configuration the façade is often composed by a perforated skin (as an overlapped layer), which surrounds it. It is the rhythm and the size of the perforations that creates its appearance. Shadows and light are very important. But this is not certain a rule. There are a lot of examples of these façades and, in this case, the colour is mostly monochrome: for example Bent Façade in Amsterdam by Chris Kabel & Abbink de Haas (2012) with its perforated whitish aluminium skin or The Orange Cube in Lyon designed by Jakob + MacFarlane Architects (2010), completely orange as its name. In the 3D configuration the colour of the façade can be slightly neutral (as the silver-grey colour of certain metals) or a combination of hyper saturated ones or even a tasteful chromatic contrast to create an effect of vibration. The last one can be seen in the green-yellow cladding of the Public Toilet Unit, in Uster (CH) designed by Gramazio Kohler Architects (2011). Otherwise, a light steel cladding that creates sinuous shapes imitating the desert sand is represented by the envelope of the Zahner Factory Expansion in Kansas City designed by Crawford Architects (2011).

The aim of this paper is to propose a synthesis of the effects that can be obtained on shading façades by means of the combination of three elements: colour, shape and pattern, both in the 2D mode and in the 3D mode. Demonstration of what will be discussed in the paper will occur through the analysis of some significant case studies.

## 2. 2D Shading Façades

Here, the term 2D Shading Façade means those architectural envelopes that are characterized by a shading skin consisting of flat elements overlapped to the façade itself. These elements can be traditional louvers, bi-dimensional shading panels,

perforated flat skins. These façades are mainly characterized by a monochrome colour. A popular alternative solution is the pixelated façade (always bi-dimensional). We found examples of pixelated 2D shading façades, for example, in the work of Sauerbruch-Hutton architects: GWS Tower in Berlin, Police and Fire Station in Berlin and so on. In these solutions the pattern is composed by regular shaped elements (square, rectangle etc.). They can be coloured all with the same colour (i.e. natural aluminium) or they can be treated as pixels of different colours (different 2D colour combinations).

Perforated flat skins façades seem to be very common today. The pattern of the façade is constituted by holes and/or cuts of different shape and dimensions. In this way colour seems to be less important than the game of shadows created by the holes. The shape of the cuts and their rhythm can create various patterns and drawings on the skin of the façade producing tension or fluidity.



Fig. 1 - Bent Façade by Chris Kabel, Amsterdam. Photo © Hans Peter Föllmi for IC4U



An example of perforated flat skins façade is Bent Façade in Amsterdam (2012). The façade was designed by Chris Kabel, professor at the Academy of Design in Eindhoven and the Cantonal School of Art in Lausanne, for a residential building designed by the architectural firm Abbink X de Haas in the centre of Amsterdam. The external cladding is composed of aluminium plates perforated by using a special punch which fold the cut plate upwards or downwards (Fig. 1). The small bent hexagonal surface may reflect light or create a shadow. This “pointillist” technique allows to create drawings on the metal plates avoiding the high costs of the laser cutting technologies. The plates are then powder coated to maintain a white colour that recalls the traditional painting of the courtyard houses along the canals in Amsterdam. The final result is an architectural envelope which looks like a light veil that covers the entire building, and which acts as a sun shading system for the translucent parts [2].

Another example of perforated flat skins façade is the Orange Cube in Lyon, France, by Jakob + Macfarlane Architects (2010). The building was conceived as a cube in which is carved a giant hole, created to respond to the need of an aerodynamic design. The hole creates a void, piercing the building horizontally from the river side inwards and upwards through the roof terrace. The building was designed on a rectangular base (29 x 33m) made of concrete pillars and stands on 5 levels. A light façade with seemingly random openings is complemented by a perforated metal over-cladding. The second skin appearance is obtained by a pixilation process of the dynamics that accompany the movement of the river (Fig. 2).



Fig. 2 – The Orange Cube by Jakob + MacFarlane, Lyon. Photo © Nicolas Borel

The orange colour refers to industrial paints often used in the areas of the harbour. In order to create the void, Jakob + MacFarlane worked with a series of volumetric disturbances related to the subtraction of three conical volumes disposed on three levels: the ground floor corner, the corner of the façade and the roof. These perturbations generate spaces and relations between the building, its users, the site and the natural light. The cladding design is not accidental but dictated by precise geometric rules. The orange skin, with holes of different sizes, makes it look like a building surrounded by a large spider web [3]. In 2015, near the Orange Cube along the banks of the Saône river in Lyon, the Green Cube building was completed. Designed by the same architects, the building's envelope is composed of a light, primarily glazed façade, doubled with an irregularly perforated aluminium cladding. The pattern of the perforated elevation was created by French artist Fabrice Hyber with a cinematic approach that references the movement and flow of the river Saône. The bold choice of green is seen as a reference to the colour of the river and it is typical of Hyber's work.

### **3. 3D Shading Façades**

Here, the term 3D Shading Façade means those architectural envelopes that are characterized by a shading skin consisting of three-dimensional elements. Not a flat façade but a combination of protruded components, combined in regular or (apparently) irregular patterns. In general there seems to be two types of 3D Shading Façades pattern schemes: with regular geometric shapes (and different levels of complexity) or with fluid shapes (i.e. liquid architecture).

An example of 3D Shading Façade with a regular geometric pattern is the envelope of the public toilet designed by Gramazio Kohler Architects. The toilet has been developed for the city of Uster (Switzerland) in 2011. It is a prototype for a new typology of urban infrastructure which had to be installed, in different variations, at several places on the city territory. The parametric design of its façade, consisting of folded, vertically arranged coloured aluminium strips, can adapt to changing building sizes and shapes due to its modularity. The colour scheme is conceived to adapt to different surrounding contexts. The depth of the folded structure and the varying reflection angle of the light on its structure, in combination with the slightly different colours of the single strips (shades of green), generate a shimmering effect that changes depending on the sun as well as the observers' position [4].

The façade is composed by 295 folded aluminium strips. Each strip is laser-cut and hand-folded. The strips are clipped and bolted onto 18 laser-cut aluminium sheets that are mounted to the façade of the prefab module called "City". Similar to a prism, the variations of green are transformed by sunlight as well as the angle of view. The envelope of the building, although formed by static elements, thanks to the shape and colour of the components, seems to have the ability to change its colour depending on the point of observation.

Another example of 3D Shading Façade with a regular geometric pattern, but created with a very complex scheme is the Façade of Eskenazi Hospital parking structure at Indianapolis in Indiana (USA), completed in 2014. The façade design was entrusted to Urbana, an office directed by Rob Ley that deals with experimental design (art, design, architecture) using materials formal and innovative approaches

with the aim of creating environments that respond to human experience [5]. A project line similar to the one theorized by the famous Dutch architect Kas Oosterhuis according to which “contemporary architecture should focus on the ability to react, adapt, quickly change according to the environment or the profiles” [6]. The peculiarity of Eskenazi Hospital parking structure façade lies in having a dynamic appearance despite being made up of static elements. Instead of an active kinetic approach (kinetic façade) [7], to minimize the possible problems related to the maintenance and longevity the designers have decided to take advantage of a static system. The goal of the project was to transform the typical appearance of the multi-storey car park - generally not appreciated by the community - through the use of Binary Terrain, a technology that was developed for DEM: a digital elevation model that allows the representation of the distribution of the altitudes of a territory, or another surface, in digital format. The digital elevation model is typically produced in raster format by associating each pixel to an absolute altitude. This technology was helpful to the design of the façade. The result is an uneven surface constituted by 6,500 inclined metal plates designed according to a colour strategy that is articulated on an east-west axis, creating a perceptually dynamic façade system that provides the observers with an original visual experience depending on their point of view and the pace at which they move through the site. In this way, pedestrians and slow vehicles in the immediate vicinity of the hospital, moving through the front gardens, experience a varied change of brindle colour (from blue to yellow and vice versa), while motorists traveling on W. Michigan Street experience a change of faster and different chromatic gradient according to the direction of travel.

From the chromatic point of view, the colour scheme is relatively simple since the west side has a deep blue colour, while the east side has a golden yellow colour. The different angle of the panels is already sufficient to create the illusion of other shades (Fig. 3).

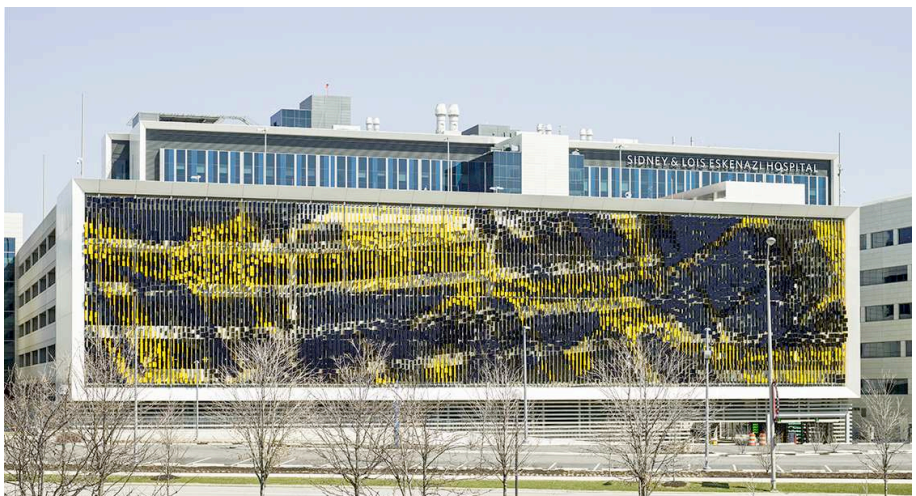

Fig. 3 – Parking Structure Art Façade by Urbana Studio, Indianapolis. Photo © Serge Hoeltzsch

To achieve the desired effect the designers had to work on the repeatability of the pattern or through combinations of the same which allowed creating the right alternation, necessary to the perception from various angles (Fig. 4).

From the perceptual point of view, the main façade when viewed from only one side appears completely yellow or completely blue. As the viewer moves from the yellow side to the blue side he has the perception of a domino effect: first the metal plates appear blue, then yellow and then they seem to disappear against the dark background of the building. The perception varies according to the height of the observer, the scrolling speed, but also in relation to the distance. From a frontal view it has a fluid but static appearance: a yellow flow over a dark blue background. When viewed from one side it appears completely yellow or completely blue. When viewed from a certain distance the bi-colour scheme changes its shape. If viewed from another distance it seems not to change etc.

An example of 3D Shading Façade with a fluid shapes pattern is the envelope of the Zahner Factory Expansion designed by Crawford Architects (2011). The building is located in Kansas City, Missouri, USA. The location for the expansion is connected to the northern façade of a 30-years-old weathering steel clad Zahner's facility and lies on a concrete paved yard surrounded by a "trivial" fence. The goal of the design was to convert the area into a large column-free assembly space, with ample clear height to move material around on 2 large cranes, and make a seamless connection to the existing factory floor. Beyond the mere utility, the facility needed a very bright and luminous space. Zahner is the factory that created many of Frank Gehry's Zaha Hadid's special metal shapes. Following this know-how through an intensive design research, the form for the façade was derived from metal oxidation patterns inspired by those found on Zahner's campus. The final graphite concept sketch drew inspiration from multiple patterns to create a form that was specific to the proportions and context of the expansion. Once the sketch was complete, a computer based algorithm converted the sketch's tonal values into a 3-dimensional digital surface model of the façade. The resulting form grows out of the rigid, solid geometry of the existing building's east façade with a single sweeping motion, and increases in complexity as it moves around the corner to the west [8].

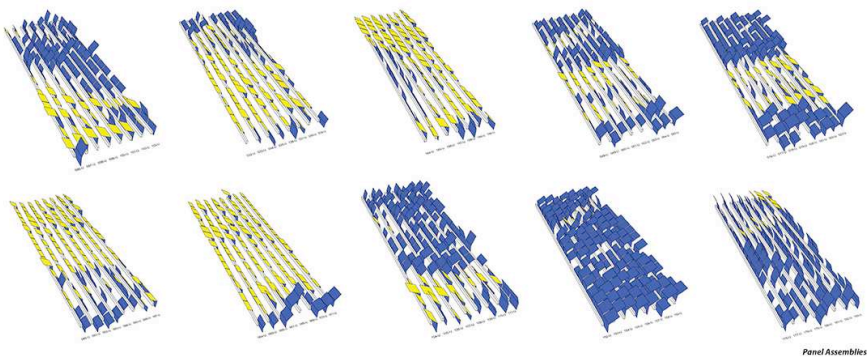

Fig. 4 – Parking Structure Art Façade by Urbana Studio: façade design process. Drawing © Rob Ley (Urbana Studio)

Articulation of the abstractly based model was closely developed with Zahner's engineers and utilizes a variation of the ZEPP (Zahner Engineered Proprietary Panel) system. The system's key components are vertically oriented fins made from a half-circle shaped aluminium extrusion riveted to a water jet cut 5mm aluminium plate. These fins are commonly used as a structural backup system behind many of Zahner's organic façades with a skin applied to their surfaces. In this case the skin is left absent both exposing and expressing the structural skeleton beneath. Placement of the fins is every 60cm on centre with a dry-set glass panel system in-between producing a structural curtain wall set on a cast-in-place concrete base [8]. The result is a dynamic, rippling surface that recalls the sinuous lines of the sand. The colour of the vertical sinuous fins is the silver-grey of aluminium. The rounded corners and soft surface make the building appear as a light and evanescent object, although it is built with strong materials like concrete and aluminium. The spaced vertical fins constitute a pattern that gives lightness to the entire structure and provide a decisive contribution to the envelope design.

#### 4. Conclusions

Nowadays in the field of construction "there is no limit in expressing yourself in the way that best suits to you. This leads to a dichotomous condition in which the good designer is able to make true works of art and place them appropriately in the territory, while the designer without quality is allowed to produce vernacular buildings" [9]. All these examples of buildings undoubtedly move from a conception of architecture as an artistic expression, contrary to the assertions by some academy still pursuing the idea that "architecture is not an art, because whatever you need a purpose should be excluded from the sphere of art" [10]. From this point of view it is evident that all the façades analysed provide a deep research and development in the use of pattern, shapes and colours by the designers who very often, as we have seen, are working side by side with artists. Dealing with static or dynamic façades the choice seems to be made between 2D or 3D façades, simplifying between flat or volumetric surfaces. In all the cases the pattern design cannot be separated from the choice of colours. The keyword that seems to link all the buildings that we have analysed is "fluidity".

#### Bibliography

- [1] R. Arnheim, "Art and Visual Perception: A Psychology of the Creative Eye", University of California Press, Berkeley and Los Angeles, 1954.
- [2] A. Premier, editor, "Innovazione Sostenibile per l'Architettura: materiali, tecnologie e prodotti", Maggioli, Rimini, 2014.
- [3] A. Premier, "Facciate Metalliche", UTET, Torino, 2012.
- [4] <http://www.gramaziokohler.com/web/e/bauten/188.html>
- [5] <http://rob-ley.com/May-September>
- [6] K. Oosterhuis, "Hyper-Bodies: Towards an E-Motive Architecture", Birkhäuser, Basel, 2003.
- [7] K. Gasparini, "Schermi urbani. Tecnologia e innovazione - Nuovi sistemi per le facciate mediatiche", Wolters Kluwer italia, Milano, 2012.
- [8] <http://www.archdaily.com/169206/zahner-factory-expansion-crawford-architects>
- [9] P. Zennaro, "Il Colore delle Scuole", Maggioli, Rimini, 2015, pp. 21-22
- [10] A. Loos, "Ins Leere Gesprochen Trotzdem", Herold, Wien and Munich, 1962



# Questioning Mediterranean white

<sup>1</sup>Maria Pompeiana Iarossi, <sup>1</sup>Cristina Pallini (\*)

<sup>1</sup>Department of Architecture, Built Environment and Construction Engineering, Politecnico di Milano, mariapompeiana.iarossi@polimi.it, cristina.pallini@polimi.it

## 1. Introduction

Travel guides and posters often advertise the Mediterranean showing picturesque white villages, with touches of colours restricted to window casing, shutters or fence panels. Against a background of pine tree forests, dense shrubs, clear sky and deep blue sea, even brand new buildings - as long as they are white - may easily fit into the picture. [1] [2]

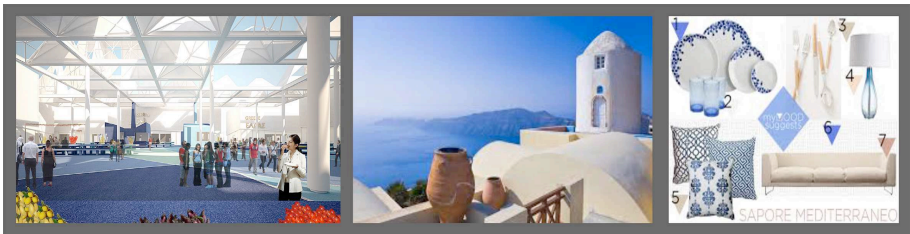

Fig. 1 – The conventional Mediterranean white-blue colour code, at Expo 2015 (Bio-Mediterranean cluster); in a travel poster; in the "Sapore Mediterraneo" (Taste of Mediterranean) furniture catalogue.

In such Dionysian settings, light and shadows on white archaeological remains somehow epitomise Apollonian reason. To many architects, the dazzling light of the South is a constant reminder of Le Corbusier's definition of architecture: *le jeu, savant, correct et magnifique des volumes sous la lumière* (the masterly, correct and magnificent interplay of masses brought together in light). As architects we can start investigate the much-debated myth of *mediterraneità* (Mediterraneity) by consulting travel literature, where ancient classic architecture is often extolled as a set of unequalled principles, albeit deprived of colours.

Benedetto Gravagnuolo has outlined a genealogy of Mediterranean architecture tracing the origins of Greek revival in the early eighteenth century [3]. Endless travel accounts, notes, sketchbooks, and projects, turned classical antiquity into as common term of reference for intellectuals, artists and architects. Many *cahiers de voyage* however, with few exceptions [4] [5], removed colours from the subject portrayed, laying emphasis instead on the metaphysics of pure volumes, rendered even more iconic by flat roofs. The absence of colour in the anthropic landscape of the Mediterranean was so powerful as to blur the binary opposition between classical and vernacular. White compared the Pentelic marble of the Parthenon, the

(\*) Note: This paper is the initial result of collaboration between the authors on the subject matter. M.P Iarossi treated the Italian case, covering issues related to representation and the carnet de voyage. Iarossi's study of Santa Cesarea Terme - and its "changing colours" - required extensive fieldwork, made possible by Dr. F. Pisanò and other members from the local Technical Department, to whom both authors express their warmest thanks. C. Pallini mainly dealt with topics concerning architecture and architectural debate, mainly covering Greek case studies, based on previous research on the relationship between architectural design, settlement dynamics and urban change.

lime-washed medinas of Maghreb, the fine villages of Southern Spain, Ibiza, Greece and Italy, the limestone quarries of Sicily, as well as the small Anacapri houses portrayed by K.F. Schinkel [6].

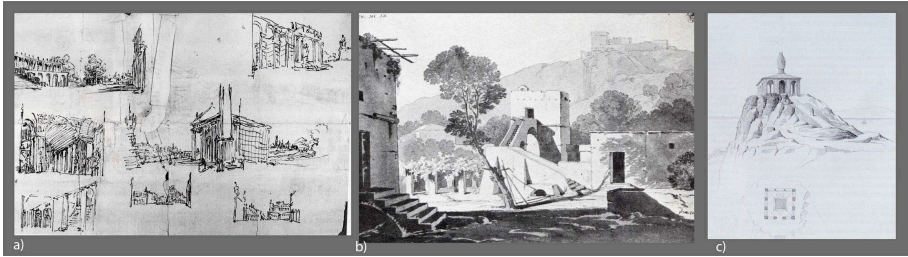

Fig. 2 – Mediterranean landscapes in the *Cahiers de voyage*: a) J. De Villanueva, sketches of places and monuments in Rome (1762); b) K.F.Schinkel, Anacapri houses (1803-1805); H. Labrousse, Santa Rosalia on Monte Pellegrino, Palermo (1824-30).

Being unrelated to any specific building material, white lends itself to visualise the concept of “timeless architecture”. If ever, colours animate the interiors, which residents may customise in contrast with the monochrome outdoor space. In the absence of colour, architecture seems free from the constraints of building materials and techniques, as if we perceived readily measurable solid forms. Besides, whitewashed villages appear just like architects’ models, often following the convention of mat white, as a means of emphasising volumes without distraction of colour, texture or material. The International Style imagery fuelled this “tyranny” of white even further, as shown in 1930s Tel Aviv, labelled as the White City for its many Bauhaus buildings by German-Jewish architects [7]. It may be added that many architects claiming a modern lineage – i.e. the New York Five - adopted white as a distinguishing feature for their buildings.

## 2. Restoring colours to the realm of classicism

In the late eighteenth century, many European artists and architects became acquainted with the canons set by the German archaeologist J.J. Winckelmann (1717-1768), thus the idea of white classical antiquity became established knowledge. Yet Winckelmann never set foot in Greece. He drew his code of ideal beauty from copies of ancient Greek sculptures by Polyclitus, Phidias and Praxiteles, which he found in Rome while working as Prefect of Antiquities. This code of ideal beauty also influenced the allegedly archetypal idea of Mediterranean art, as encompassing local differences, despite the evidence that any traveller could easily gather locally [8]. Following Winckelmann’s and Goethe’s footsteps, many German architects travelled to the South [9], some joining Swedish, Danish, English and Spanish colleagues, as well as groups of French *Pensionnaires* based at Villa Medici in Rome [8]. This was a well-travelled generation of intellectuals, who gained a direct understanding of classical antiquity and used drawing as a tool to capture the essence of mythical remote places. Their sketches occasionally circulated as fair copies, often with etching in black and white. While colourless images of the ancient world were becoming popular, scholars from other disciplines (mainly historians and philologist) were also turning their attention to the Mediterranean.



Among them was A.C. Quatremère de Quincy (1775-1849) [10], who distanced himself from Winckelmann's ideas arguing that polychromy could be obtained by *toreutics* (artistic metalworking), using metal foils hammered or engraved to form minute detailed reliefs or small engraved patterns (an example is the *riza* silver foil still used for Greek-orthodox icons).

As early as 1830, the German-born French architect J.I. Hittorff (1792-1867) detected traces of polychrome stucco on the Greek temples of Selinunte, guessing the real colours of ancient Greek architecture [11]. Together with British architects C.R. Cockerell (1788-1863) and T.L. Donaldson (1795-1885), Hittorff was part of a committee to determine whether the Elgin Marbles and other Greek statuary among the holdings of the British Museum were originally coloured (1836). Based on this experience, Hittorff developed his theory on the genealogy of western architecture [12], shifting the meaning of classical antiquity from ideal perfection to the actual origin of the art of construction. According to Hittorff, the *guttae* - stylized drops below the triglyphs in the Doric order – were a marble equivalent of earlier pins used to fasten wooden beams, proving that marble temples derived from earlier wooden structures, and that colour used to protect wooden elements.

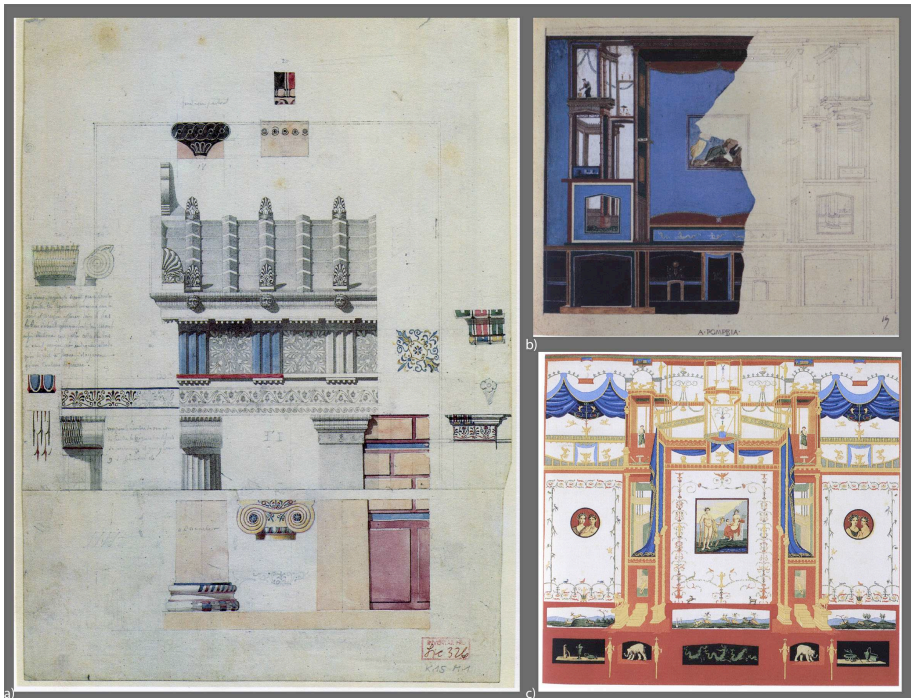

Fig. 3 – Colour in classical antiquity: a) J. I. Hittorff, polychrome details of the temple of Selinunte B (1827-30); b) F. Duban, a fresco from Pompeii (1824); K.L.W. von Zanth, a fresco from Pompeii, from a house located between temple of Hercules and the Forum (1832).

When reaching archaeological site became relatively easier, more scholars contributed to restore colours to the realm of classic art and architecture [8]. In 1824, the French architect and illustrator F. Duban (1797-1870), who travelled extensively in Italy, produced the first copies of the colourful Pompeian paintings. The German archaeologist W.J.K. Zanth studied Roman wall painting, while G. Semper rediscovered *architectura picta*, the painting simulation of architecture so popular in Genoa. Despite the increasing number of colourful drawings produced by archaeologists and architects, colour as a fundamental part of Mediterranean townscapes did not reach the collective imagery.

### 3. Commonplaces about Mediterranean white and modern architecture

Independence of Greece in 1830, after four centuries of Ottoman rule, brought colours back to Athens. In an effort to connect an uncertain future with the glorious classical past, Athens was equipped with many Neo-classical public buildings, mostly designed by German architects and painted in bright colours. The Neoclassical trilogy of Athens - the Academy, the Library and the University – was a kind of manifesto for similar buildings all over Greece: theatres and churches, schools and town halls, banks and train stations, as well as many private houses. Their basements, columns and corniches were always white whereas the remaining part of the façade was usually light ochre yellow, recessed walls were dark red, with many light blue surfaces in the interiors.



Fig. 4 – The revival of polychromy in Athens. Above: Athens University historic building, C. Hansen (1839-1841); below (left) the Zappeion, T. Hansen (1874-1888) and (right) the Old Parliament House, F.L.F. Boulanger (1858-1875).

In Thessaloniki and Northern Greece (still under Ottoman rule until 1912) the German trained architect Xenophon Paionidis built many Greek schools and community buildings, experimenting extensively with the combination of classical elements and exposed building materials, such as bricks or local stones.

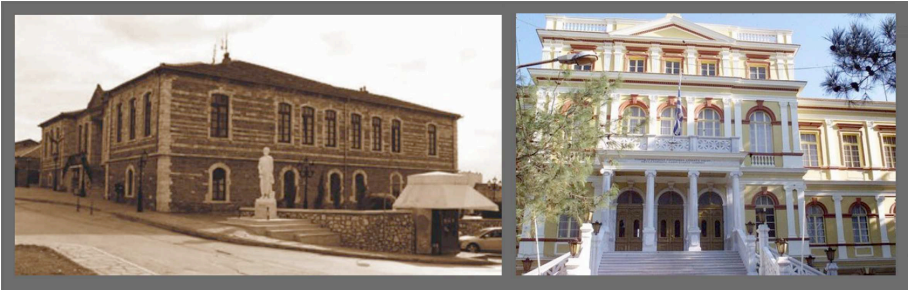

Fig. 5 – The use of colours and different building materials by X. Paionidis: School at Polygyros, Chalkidiki (1909), Papafion Orphanage at Thessaloniki (1894-1904).

While all these experiences merged almost seamlessly into Eclecticism, a somehow stereotyped idea of Mediterranean architecture re-emerged later as a source of inspiration for modernist and contemporary architects [13]. In this process, the charismatic figure of Le Corbusier played a fundamental part [14] [15]. However, according to J.-L. Bonillo, Le Corbusier's key references were at least two: the white Parthenon and colourful ever-changing Istanbul [16]. Adolf Max Vogt also argued that the *Voyage d'Orient*, and Ottoman architecture, left a permanent mark on the master [17] who, according to Yorgos Simeoforidis, was deeply fascinated by Byzantine architecture in the enchanting landscape of Mount Athos and the Greek islands [18]. Questioning Mediterranean white, we should go back to the summer of 1933, when CIAM members started from Marseille their sea voyage across the Mediterranean. In Athens, Le Corbusier pronounced the famous phrase “the Acropolis made me a rebel” [19]. Later on, CIAM members sailed to the Cyclades where, almost unexpectedly, they found traditional houses which embodied just the same architectural ideas they had been working out for a decade or so [20]. Cycladic villages expressed timeless principles: the iconic combination of pure volumes, flat roofs and white walls without decoration. Before the diffusion of white paint, fabricated and mass-produced only after 1905-15, these walls were painted white using asbestos. Thus, the absence of colour somehow equated the Pentelic marble of the Parthenon with the simple lime-washed forms of everyday homes. Back in Athens, CIAM members also visited the new schools by young Greek architects: dissymmetrical compositions, functional layouts, geometry of pure volumes in perfect harmony with the Attic landscape. On 4 August 1933, the Greek newspaper *Neos Kosmos* published an article entitled “*Foreigners' admiration for our new school buildings, the sign of an advanced civilization*”. The French Pierre Chareau declared that Greek architects had introduced terraces and balconies to adapt their building to the local climate, rather than copying western projects.

Despite limited technical and financial means, the scale of intervention and speed of execution marked an undeniable success for the new Greek schools, which achieved considerable press coverage attracting much contemporary and later scholarly work [21] [22]. The reason why the Greek government undertook such a major effort at the end of the Greco-Turkish war, can be partly explained considering the compulsory exchange of population between Greece and Turkey ratified by the

Treaty of Lausanne (1923). Over a million refugees arrived in Greece, nearly  $\frac{1}{4}$  of the country total population. In an effort to re-establish socio-economic and cultural life, many cities were radically reshaped, and school buildings – where learning Greek was to forge new cultural identities – became a dominating theme: experimenting with the combination of indoor and outdoor facilities, of functional and collective spaces, often creating a sort of microcosm.



Fig. 6 – Modern Greek schools. From left to right: Athens the school on Odos Kololetti visited by the CIAM Delegation, N. Mitsakis (1932); Thessaloniki, Agia Sophia School Complex, N. Mitsakis (1928-1932); Thessaloniki, Experimental School, D. Pikionis (1933-37)

As early as 1938, Greek architect Patroklos Karantinos published a book showing some of the 3000 primary and secondary schools built all over Greece [23]. Karantinos carefully selected the closest possible examples to the modernist aesthetic, printed in black and white, these buildings perfectly matched the “white walls” canon. Yet, almost none of them was completely white, including as they did light yellow, dark red and light blue, the three colours of the Greek Neoclassic tradition. Besides, not every school anticipated the new architecture. Young Greek architects were actually seeking an original balance between local features and the forms theorized by the Modern Movement. Some beautiful schools did feature simplified eclectic forms bearing a tangible reference to the various architectural traditions across Greece. In Thessaloniki for example, in the Mevlhané and Aghia Sofia school complexes (1931), Nikos Mitsakis reinterpreted Byzantine stylistic elements by reducing them to pure coloured volumes. A few blocks away Dimitris Pikionis built the experimental school (1935-36) reinterpreting the architecture of Macedonian houses, with pitched roofs, wooden elements, and colours.



Fig. 7 – Thessaloniki, Views of the Civic Axis designed by E. Hebrad as part of the reconstruction plan in 1918 and completed in the 1950s

In Thessaloniki, the use of colour was part of a wider process of city reconstruction, undertaken after the fire of August 1917 according to the plan by the French

architect Ernest Hebrard. Rebuilding Thessaloniki meant grafting a new city centre onto areas loaded with memories of the past. To do this, Hebrard conceived his Civic Axis, a series of open spaces, each with its own function, rising from the seafront to the upper town, characterized by colourful arcades and neo-Byzantine facades to remark the city’s newly-acquired Hellenic identity [24].

#### 4. Not all towns in Puglia are white

Italy-bound travellers are likely to find increasingly frequent advertisement of the dazzling whitewashed towns of Puglia: *“like the Greek islands and southern Spain ... ancient towns with Roman, Greek or Saracen roots and WLAN access. Though ancient the white towns in Puglia are still very much alive”* [25]. Among these, is the spa town of Santa Cesarea Terme on the east coast of lower Salento, famous since the second century AD for the therapeutic properties of its sulphurous springs, which formed a series of grottos at the feet of a rocky terrace of the city [26].



Fig. 8 – Santa Cesarea Terme in a map of 1935; b) panoramic view of the historic centre: to the left, Villa Sticchi; c) view of the level of Piazzale degli Alberghi; d) view of Via Roma; e) view of the church on Via Roma.

In such a scenic setting, Santa Cesarea is particularly impressing from the sea: a unitary “urban scenography” whose off-white colour mitigates the different architectural styles, attuned with the Eclecticism then prevailing. Almost all facades are painted in a very narrow tones of colours, ranging from white lime-wash to shades of ivory and pale yellow. Only few monumental buildings break this rule: watch towers in natural stone, a church in dark yellow tuff, the bright decorations of Villa Sticchi. The latter belonged to the family who was once in charge of exploiting

the local springs, which perhaps explains its Moorish style, featuring a red basement and a fine combination of goldish-beige and light blue.



Fig. 9 – The traditional colours of Santa Cesarea Terme: a comparison between Villa Sticchi (left) and Villa La Meridiana at Santa Maria di Leuca with its *bagnarola* pavilion by the sea (right).

As if bending the earth into the sky, these colours were widely used in Salento, as at Santa Maria di Leuca [27], where each villa had its own colour code, used to identify ancillary buildings, such as the typical “*bagnarole*” pavilions by the sea. Wherever time and salt have corroded the superficial layers, bright colours appeared from below in many buildings of Santa Cesarea: red and yellow (sometimes combining in random decorative motifs), and many shades of blue. Bright colours were used for entire wall surfaces and, even more often, for architectural elements, as cornices and profiles. Despite being very unusual elsewhere in Italy and Europe (partly because of the price) blue and light blue were very much the fashion in Salento



Fig. 10 – Santa Cesarea Terme: bright colours resurfacing from whitish superficial layers on exterior and interior facades.



Fig. 11 – Santa Cesarea Terme, via Piave: a white facade originally characterised by a series of coloured architectural elements (basement, cornices, ashlar work).

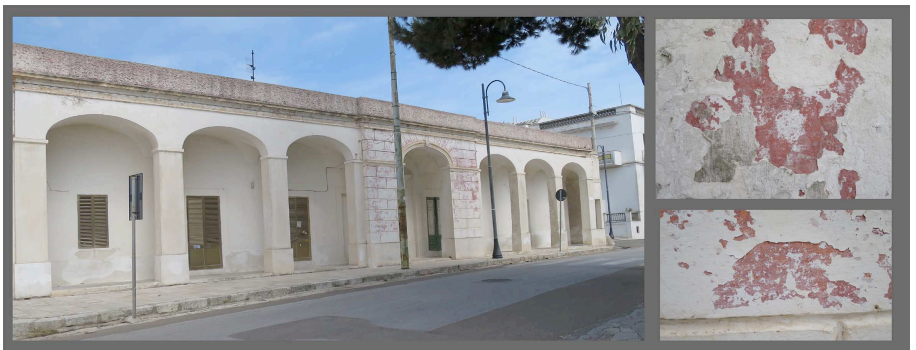

Fig.12– Santa Cesarea Terme, view of via Umberto I and details of the corroded superficial layers.

Quite paradoxically, the 1994 Master Plan of Santa Cesarea established that tuff walls be painted white or coated with white plaster; alternatively, external walls could to be finished with exposed concrete or cement plaster. Yet, there is no historical record of any such colour restriction: the 1935 building regulation simply stated that all factory walls and hallways on public spaces be kept in good condition and plastered avoiding dark colours. The 1988 building regulation did not include

any colour restriction. In the absence of detailed photographic records showing how the buildings of Santa Cesarea looked like before being “bleached”, we can only but survey the entire housing stock of the city centre, mapping the colours found on each building. We can also date the building stratigraphy by analysing the chemical components of each layer of colour. A rare colour photograph of the early 1960s allows us to anticipate some general comments. This general view of Santa Cesarea from the north, shows Piazzale degli Alberghi as characterised by colourful buildings, among which the blue-grey Albergo Palazzo is clearly standing out. Originally a resort for wealthy families, ever since the 1960s Santa Cesarea has become a spa town for short-term tourists who rent houses on a fortnightly basis (the average thermal treatment). Lime-washed facades became more and more popular as a cheap way to maintain the housing stock. Far from being a distinguishing feature of Santa Cesarea, the off-white townscape is rather bearing reference to the practicalities required by its recent revival for a less place-based clientele.

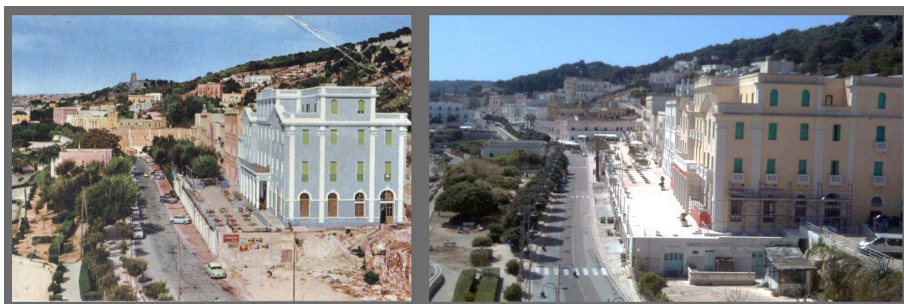

Fig. 13 – Santa Cesarea Terme, the same street as it was in the early 1960s (left) and as it is today (right).

## 5. Concluding remarks

In questioning Mediterranean white, we certainly come across a great number of paradoxes. While colours were restored to the realm of classicism, the revival of classicism reached its highest expressions in many European public buildings conceived to resemble monuments of antiquity, and therefore white (often using local stones, whether yellow tuff or Roman travertine, as equivalent to Pentelic marble). In Athens however, the revival of classicism led by German architects acquired its own dynamics, bringing back colours in full force, as rediscovered in classical models. After decades of International Eclecticism, the Mediterranean townscape was caught once more into the cross-fire of stereotypes: “timeless architecture”, “classical archetypes”, and the rising imagery of the International Style.

The Greek architect Patroklos Karantinos, who can be rightfully included among the pioneers of modern architecture, left a series of beautiful reflections on the Mediterranean light, and on the architecture of museums in Mediterranean countries. Recalling a trip to Olympia on a clear winter morning, he argued that the pediments of the temple of Zeus, the Nike of Paionios, the Hermes of Praxiteles were created in light. When locked inside a building, they lose every vibration of life, as the frozen



Titans. Thus, the Mediterranean requires an architecture of its own, different from London or Berlin.

By splitting the Mediterranean into its fragments, we may restore to its extraordinary cities the many and varied architectural traditions that were able to nurture and blend. Studying in depth a number of case studies, the much-debated of *mediterraneità* (Mediterraneity) turns to be far less “monolithic”.

Luckily, however, as Mediterranean cities and their architecture are becoming central theme for scholars from many disciplines, new perspectives are coming to the fore, most of which are difficult to fit into mainstream ideas. This is particularly true for lesser-known European architects, engineers and builders, who actually spent their life and made a career in Mediterranean cities, as well as when dealing with the actual (historically contextualised) construction/reconstruction of the cities concerned.

## Bibliography and sitography

- [1] M. Wigley, “White Walls, Designer Dresses”, MIT Press, Cambridge (MA) 1995.
- [2] V.I. Atroshenko and M. Grundy “Mediterranean vernacular: a vanishing architectural tradition”, Rizzoli, New York 1991.
- [3] B. Gravagnuolo, “Il mito mediterraneo nell’architettura contemporanea”, Electa, Napoli 1991.
- [4] [www.archiviobottoni.polimi.it/Bottoni\\_opere/Regesto-taccuini](http://www.archiviobottoni.polimi.it/Bottoni_opere/Regesto-taccuini)
- [5] M.P.Iarossi, G. Mele, M. Rossi, “El viaje como aprendizaje. El aprendizaje como viaje: los carnés de Piero Bottoni”, 15 Congreso EGA-Expresión Gráfica Arquitectónica, Las Palmas de Gran Canaria, May 2014.
- [6] AA.VV., “Schinkel: 1781-1841: l’architetto del principe”, Edizioni Marsilio, Padova 1989
- [7] M.D. Levin, “White city: International Style architecture in Israel, a portrait of an era”, Tel Aviv Museum, 1984
- [8] V. Cardone, “Viaggiatori d’architettura in Italia, Da Brunelleschi a Charles Garnier”, Università degli Studi di Salerno, Salerno 2014.
- [9] A. Maglio, L’Arcadia è una terra straniera. Gli architetti tedeschi e il mito dell’Italia nell’Ottocento”, Clean, Napoli 2009
- [10] P. Bertoncini Sabatini, “Da Agrigento verso Atene: il viaggio alla sorgente del genio ellenico di Quatremère de Quincy (1755-1849)” in: A. Carlino (ed.), “La Sicilia e il Grand Tour: la riscoperta di Akragas. 1700-1800”, Gangemi, Roma 2009, pp. 51-72.
- [11] M. Cometa (eds), “Jakob Ignaz Hittorf. Viaggio in Sicilia”, Editrice Sicania Messina 1993
- [12] J.I. Hittorff, “Architecture polychrome chez les Grecs”, F.Didot freres, Paris 1851.
- [13] J.L.Bonillo (ed.), “Domus Mare Nostrum - Habiter le mythe méditerranéen”, Hemisud Conseil General du Var 2014.
- [14] J.-L. Bonillo, G. Monnier (eds), “La Méditerranée de Le Corbusier”, Publications de l’Université de Provence, 1991.
- [15] B. Gravagnuolo, “Le Corbusier e l’Antico: viaggi nel Mediterraneo”, Electa, Napoli 1997.
- [16] J-L. Bonillo, “Le dimensioni plastiche del mito mediterraneo di Le Corbusier”, in: [15], pp. 115-118.
- [17] A.M. Vogt, “Le Corbusier, the noble savage: toward an archaeology of modernism”, MIT Press, London 1998
- [18] Y. Simeoforidis, “Dall’Athos alle Cicladi: la scoperta del paesaggio”, in: [15], pp. 53-61.
- [19] Le Corbusier, “Air, son, lumière”, Annales Techniques, IV, 15 Oct.-15 Nov. 1933, pp. 44-46.
- [20] Le Corbusier, “Une hauteur de logis efficace”, in La Ville Radieuse, Vincent Fréal et Cie. Paris 1964 (1935), p. 52
- [21] F. Loyer, “Architecture de la Grèce contemporaine (1834-1966)”, PhD Thesis, Université de Paris, 1966.
- [22] A. Giacumacatos, E. Godoli, “L’architettura delle scuole e il razionalismo in Grecia”, Modulo Firenze 1985.
- [23] P. Karantinos, “The new school buildings” (in Greek), TEE, Athens 1938.

- [24] A. Karadimou-Gerolymou, "The Reconstruction of Thessaloniki After the Fire of 1917: A Milestone in the History of the City and in the Development of Greek Urban Planning", University Studio Press, Thessaloniki 1995.
- [25] <http://italiannotes.com/white-towns-in-puglia>
- [26] S. Coppola, L. Martella, "Sub Montem Saracenum: Santa Cesarea Terme nel Salento. Un secolo di attività politica e amministrativa 1913-2013", Editore cooperativa sociale Villaggio azzurro; S. Cesarea Terme 2013.
- [27] C. Robotti, A. Monte, "Le ville del Salento. Rilievi, modelli, decorazioni" (catalogue of the exhibition, April-December 1995), Caroli, S. Maria di Leuca 2009.

# Colour in the urban environment: a tool for the chromatic analysis of spatial coherence

<sup>1</sup>Luan Nguyen, <sup>1</sup>Jacques Teller

<sup>1</sup> Local Environment: Management and Analysis, Department of Architecture, Geology, Environment and Construction, Faculty of Applied Sciences, University of Liège, nl.nguyen@ulg.ac.be, jacques.teller@ulg.ac.be

## 1. Introduction: colour as a fundamental component in the urban environment

In the specific literature, Gustave Kahn described Paris in the beginning of the 20th century as to be uniform and monochrome due to the white colour of stone [1]. In his book "The Image of the City", Kevin Lynch used the yellowish-grey colour when talking about the city of Florence [2] while Rem Koolhaas in "SMLXL" mentioned a tint of metallic-matte aubergine, khaki-tobacco, dusty pumpkin in the description of the emerging generic cities [3]. These examples illustrate the fact that colour is an essential component of urban landscapes that inform us about the status and history of a place, through relations of dominance, integration, uniformity or heterogeneity that can be observed between its built components.

Colour takes part in the space organization: it can clarify and define a space, a form or a structure [4]. In some cases it contributes to group a set of buildings through a unifying role by using a similarity of hue between the object; in other cases colour can fragment an urban fabric with a more polychromatic palette and single out a building due to a contrast with the background [5].

Moreover, additionally to functional roles, colour can promote heritage values and collective identity. Besides marking our eyesight out with signals, colour makes sense in our visual environment, through a semantic function [5]. With the globalization, which perpetually demands uniformity in place of diversity [6], colour can preserve the specific identities of regions. "In some European regions, each village is associated with its unique colour scheme. This is also true for certain Asian regions"[7].

Colour embodies a semiotic value in the field of heritage and collective identity, generates a long time scale process for which the colorist Jean-Philippe Lenclos mentioned a "slow and long-lasting colour stratifications over time and space" [8].

Besides the unique colour scheme which identifies a city, some authors show that many cities actually appear to be « chromatically polynuclear » and that each epoch, each type of urban area is characterized by its own colour palette, which can be more or less homogeneous [9]. This chromatic burst is explained largely by urban development over the last decades.

## 2. The evolution of the city: the loss of spatial coherence in the field of urban morphology

The traditional European city appears in most cases as finite, compact, structured, organized, continuous and consistent; its spatial boundaries are further defined and urban forms are clearly perceptible [10]. The urban space of the historic city appears as harmonious and homogeneous [11], morphologically consistent, both from the point of view of shape and colour.



Fig. 1 - Aerial view of the homogeneous, structured and compact traditional city (center of Siena, Italy. Source: Bing Maps 2016).

The urbanization of the last fifty years has generated an unstructured, diffuse urban territory with blurred boundaries, composed of fragments which are very different from the inherited city; this mutation produced a dislocation of permanent structures set up in the past which supported the coherence of landscapes [5]. The complexity of these phenomena makes difficult any attempt to measure the morphology of the resulting urban fragments because of the huge heterogeneity of forms and colours.

Thus, the city today is characterized by two concomitant phenomena, due to a fast and uncontrolled economic growth: urban sprawl and urban fragmentation [12]. Urban sprawl generates areas including new configurations such as periurban housing districts and commercial zones. Urban fragmentation is characterized by an internal division in which new structures infiltrate and superimpose within the existing fabric, generating complex visual environments where the old urban patterns coexist with the new ones, both in terms of shape and colour.

These phenomena are increasingly widespread and are not expected to decelerate and to be reverted in a short time frame. "So chaos, tension are not the minimum condition of the urban experience anymore, they have become the norm and the current fragmentation occurs at all levels and at all scales" [13]. This chaotic process

generates a loss of spatial coherence and disjoints the links between elements of the urban fabric [14]. In the same idea, the geographer Rémy Allain mentioned some distended and disjointed relations between the built elements in the city when characterizing those discontinuous urban fragments [15]. Oppositely, the consistency in the urban fabric occurs when some "connectivity" is established between its components [16].

In conclusion, the urban mutations observed in the second part of the 20th century generated a significant increase in the entropy of contemporary extensions of cities, which induced a loss of meaning and coherence by dislocating permanent structures set up in the past that maintained some integrity of urban landscapes [17]. Despite these profound changes, few studies have focused on the morphological description of these emerging configurations [18].



Fig. 2 - Aerial view of the the heterogeneous, fragmented and discontinuous urban fabric (a periurban zone of Liège, Belgium. Source: Bing Maps 2016).

### **3. The lack of tools for the chromatic characterization and for the spatial coherence evaluation**

The new urban fabrics are far more complex to characterize and analyze. This is especially the case of the colour distributions that can be observed in these areas, and that are radically different from usual palettes of traditional cities [19]. The difficulty in characterizing the colours in these urban fabrics is partly due to a lack of tools for an objective analysis of colour palettes in an urban environment.

Given this lack of both affordable and reliable assessment method of colour that has been observed in the field of urban design, the main goal of the present research is the implementation of a tool that can be used to characterize chromatic attributes of an urban area. The challenge is to provide statistical and quantitative answers to these questions: how is colour organized, how does it develop its own structure in

the city? How can colour appear as an indicator of homogeneity and spatial coherence?

#### 4. Methodology for the colour analysis

We developed a protocol for the chromatic characterization of urban areas tested through an application to eighteen cases, here defined as streets, housing estates or squares, of the city of Liège (Fig. 3). All those areas have been classified among four main classes: historic center, periurban housing districts, working-class neighbourhoods and commercial zones (Fig. 4). The Table 1 below summarizes the eighteen areas that are analyzed.

We initially photographed 1.952 facades divided into the eighteen urban areas. For this purpose, a standardized protocol that defines in its early stages shooting settings (light conditions, the time of the shooting, camera settings, etc.) was applied to the eighteen areas [20]. At the end of the protocol, which also includes a white balance algorithm, we get the colour values H, S, and L (Hue, Saturation and Lightness) of the dominant colour (or “façade background” component) for each façade of the analyzed urban area.

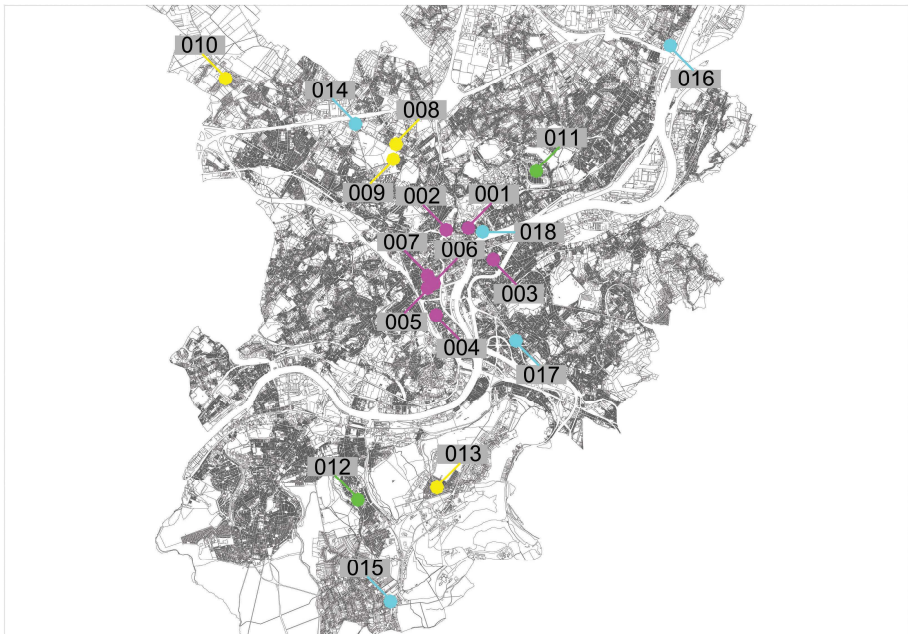

Fig. 3 - Location of studied urban fragments. Historic center (in magenta), periurban housing districts (in yellow), working-class neighbourhoods (in green) and commercial zones (in cyan).



Fig. 4 - Illustrations of the four main classes: (1) the historic center, (2) the periurban housing district, (3) the working-class neighbourhood, (4) the commercial zone.

Area code	Area name	Number of facades
Historic center		
001-HCH	Rue Hors-Château	101
002-ANG	Rue des Anglais	37
003-JDM	Rue Jean d'Outremeuse	106
004-BRO	Place Bronckart	33
005-JAR	Rue du Jardin Botanique	44
006-DAR	Rue Darchis	57
007-AUG	Rue des Augustins	57
Periurban housing districts		
008-CLO	La Closeraie	170
009-CHAR	Clos des Chardonnerets	71
010-WAR	Lotissement du Waroux	197
011-SAR	Lotissement du Sart-Tilman	190
Working-class neighbourhoods		
012-OUG	Rue Pirenne (Ougrée)	81
013-TRI	Cité du Tribouillet	207
Commercial zones		
014-ANS	Ans-Rocourt	129
015-BON	Bonnelles	71
016-HER	Herstal	125
017-FRA	Boulevard Frankignoul	205
018-FER	Rue Féronstrée	71

Tab. 1 - The eighteen analyzed urban areas are classified among four main classes: historic center, periurban housing districts, working-class neighbourhoods and commercial zones.

Starting with the H, S, L values (which can also be converted to Euclidean coordinates R, G, B), obtained for the 1.952 facades – or 1.952 individuals divided into 18 samples in statistical terms – our aim is to generate chromatic categories (or types) synthesizing the colour attribute of the studied population to understand how colour structures the city (Fig. 5). Following our aim of developing a parametric chromatic characterization, statistical tools were used to generate these chromatic categories.

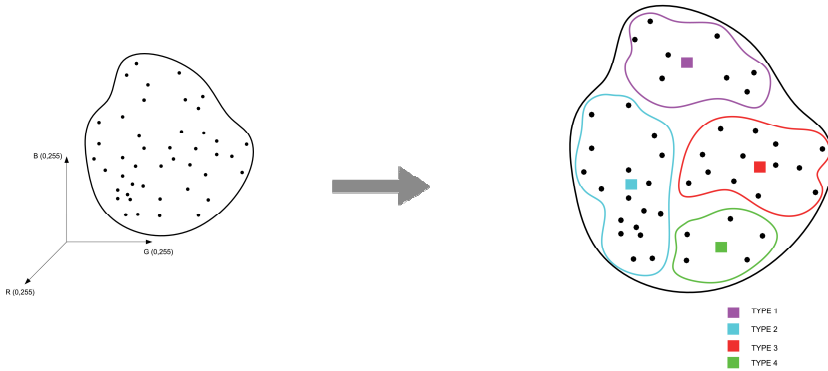

Fig. 5 - Diagram illustrating our goal: establishing a categorization of the 1.952 individuals, divided into a limited number of categories (or types).

In this way, we use a cluster analysis to gather a set of similar objects in the same group (or cluster). Because each individual has a spatial-colorimetric coordinate, it is easy to apply a K-means clustering to generate clusters. K-means is a data partitioning algorithm through an iterative process. It is a method that divides  $n$  observations into  $k$  partitions (clusters) in which each observation belongs to the partition with the closest mean (centroid), by calculating the Euclidean distance. The Figure 6 shows the iterative process that generates clusters and centroids. Furthermore, the K-means clustering technique is performed in the field of computational modelling of colour categorization [21] and data mining for systematic classification of urban form characteristics [22].

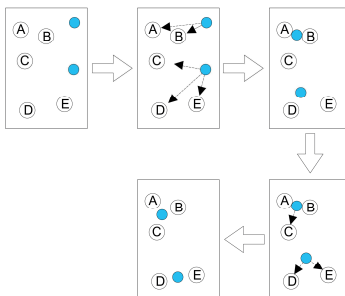

Fig. 6 - K-means iterative process generating clusters and centroids.



A cluster can be assimilated to the collection of individuals based on their affiliations to a chromatic category. The centroid is, from a certain point of view, the representative type of a chromatic category. In the application of K-means algorithm, we deliberately chose a limited number of four clusters. This number seemed to be significant enough in the process of categorization development. We applied the method to the population of individuals for which the initial colorimetric values HSL were converted into CIE Lab coordinates. The CIE Lab colour model was developed with the purpose of linearizing the representation with respect to human colour perception [23]. Therefore, the calculated distances between colours correspond to differences perceived by the human eye, which is not valid in RGB or HSL. As it is difficult to visualize in the CIE Lab space, the results are converted again in RGB and HSL spaces. Figure 7 shows the clusters of points (in red, green, blue and cyan) and the centroids (black dots). Since the centroids have colorimetric coordinates, their apparent colours can be determined: we can observe a less saturated beige (type 1), a medium saturated orange (type 2), a medium saturated red (type 3) and a light grey (type 4) (Fig.8).

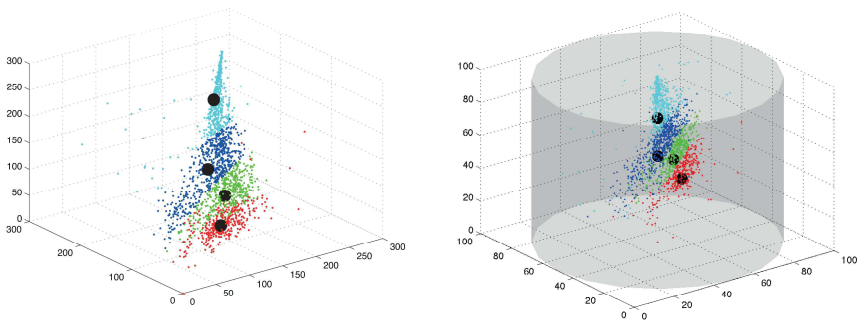

Fig. 7 - Application of the K-means clustering for the 1,952 individuals: representations of the four clusters with centroids (black dots) in cartesian RGB system and in polar HSL system.

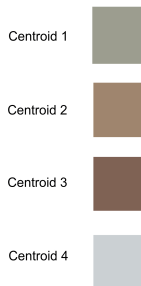

Fig. 8 - Apparent colours for the four centroids generated with the K-means clustering.

## 5. Results: towards a quantitative evaluation of the spatial coherence

Finally for each of the eighteen studied urban areas, we give the percentage distribution of the four clusters, in the form of a pie chart, which each portion is painted with the colour of the centroid (Fig. 9 and 10). Thus each urban area is characterized by a specific colour palette, or a layout of the four chromatic categories. For each area, homogeneity (or heterogeneity) is identifiable through the number and the proportion of the constituent clusters. As a result of this reasoning, the homogeneous and consistent feature of an urban area can be highlighted [20].

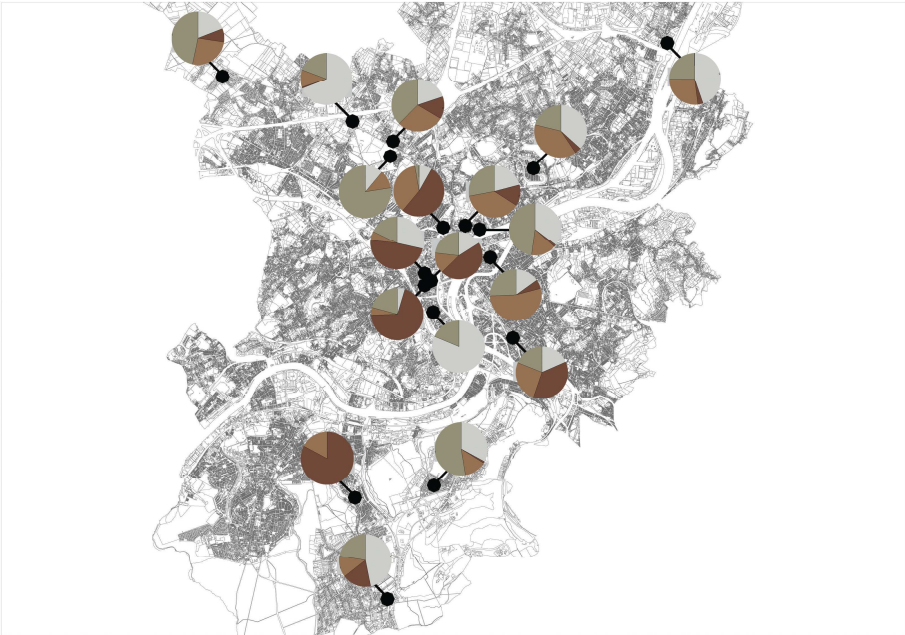

Fig. 9 - Distribution of the four chromatic categories in the 18 urban areas in Liège.

Thus in the Figure 10, we can see that the pie charts No. 4 and 12 are composed of only two types, with a predominance of one: the chart 4 represents a listed square of the historic centre surrounded by light coloured buildings (Place Bronckart) and the chart 12 consists of a set of repetitive houses in dark brown of a working-class neighbourhood (Cité Pirenne). For these two urban districts, a visual inspection of the façades clearly reveals a chromatic homogeneity that is confirmed by the graphs. The other areas, more heterogeneous, are composed of three or four types in various proportions, with the predominance of one chromatic category. We can notice that the predominant chromatic categories in the streets of the historic centre (charts 1 to 7, except chart 4) are type 2 (medium saturated orange) and type 3 (medium saturated red), while in commercial areas located in the periurban fragmented zones described in the introduction (charts 14, 15 and 16), the dominant type is type 4 (light grey).

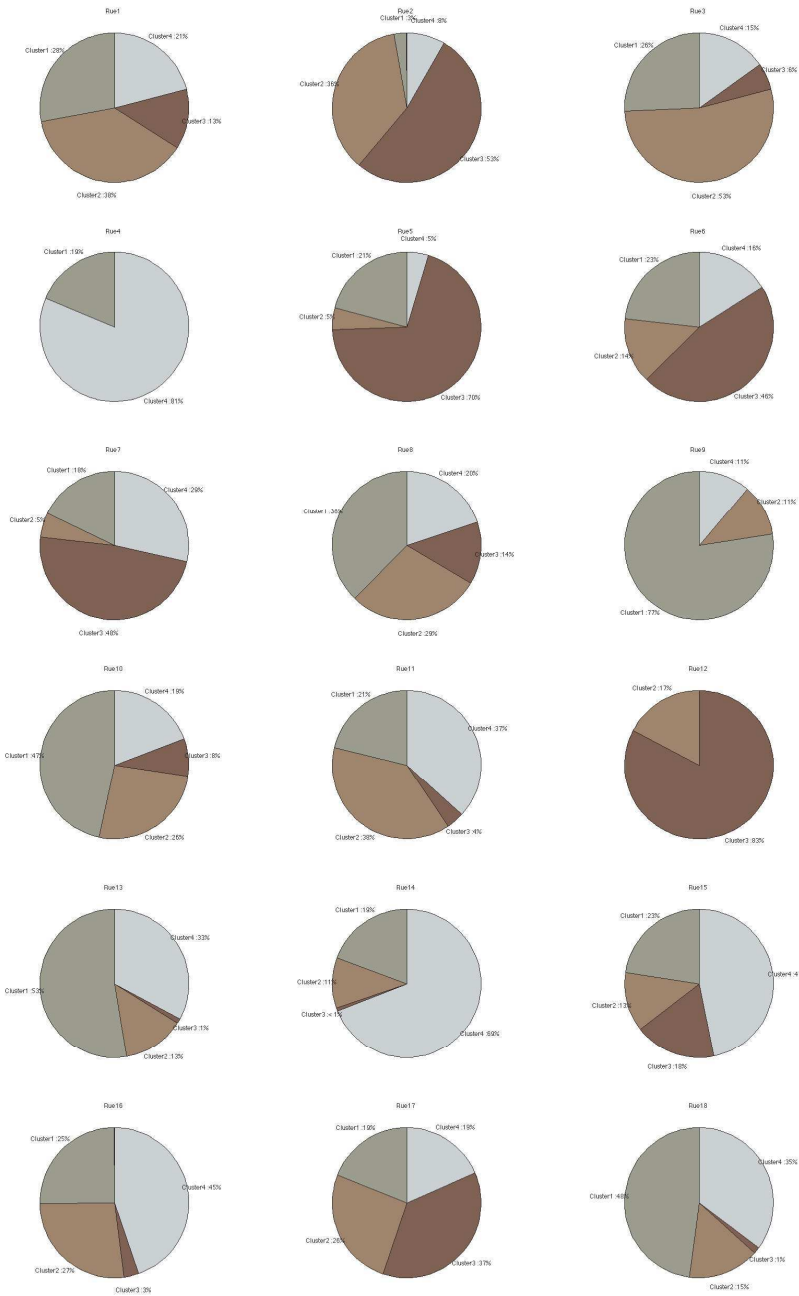

Fig. 10 - Application of the K-means clustering for the 1,952 individuals. Graphs showing the proportions of the four clusters in the eighteen urban areas.

The chart No. 17, representing a city entrance (Boulevard Frankignoul), can be assimilated to a new urban configuration and in which old buildings mix with commercial equipment. It shows the highest level of chromatic heterogeneity: four types in almost similar proportions. Visually, this specific urban fragment actually appears chaotic with saturated visual noise, complex and unintelligible [10].

From those results, it is possible to evaluate the spatial coherence of an area. It is commonly accepted that architecture is a medium for communication, as well as writing. We can therefore speak an architectural language and compare the city to a language; this approach gives to built objects a specific status of signs with meanings and according to Christian Norberg-Schultz, "for transmitting meanings, architecture should be a language" [24]. In this way, Summerson announced a "classical language of architecture" [25] and Zevi a "modern language of architecture" [26]; in both cases, the architectural vocabulary considered as an index is converted into a coded language.

In the field that concerns us, we can assimilate the four chromatic categories as the elements of a vocabulary or a chromatic index to describe the urban fabric in the point of view of the colour attribute. Urban fragments appear as sequences of elements drawn from a finite and discrete index. In information theory, they are messages for which it is possible to measure the amount of information [27]. This measure is based on the fact that the concept of information has a statistical value of the elements of an index and when the probabilities of occurrence of these elements are known, the calculation of the information is possible. We also consider that information  $H$  is measured by the binary logarithm of the improbability of the message:

$$H = \log_2 1/\pi = - \log_2 \pi$$

Therefore, from an index of  $N$  elements each with  $p(i)$  probabilities, if a message is arranged by using elements from the considered index, Shannon has shown that information  $H$  is equivalent to the following formula:

$$H = - N \sum p(i) \log_2 p(i)$$

This value  $H$ , called Shannon entropy, is also used as a variable to quantify the heterogeneity of the biodiversity in an environment [28]. Thus  $H=0$  if the set contains only one species (that means the same chromatic type in our case) and  $H=H_{max}$  if all species contains the same number of individuals (in the case where all types have a similar distribution on pie charts). Applying this formula to the 18 urban fragments, we get the values for  $H$  in the Table 2.

Our previous observations that the fragments No. 4 and No. 12 are the most homogeneous (the lowest values for  $H$ ) and the fragment No. 17 the most heterogeneous (the highest value for  $H$ ) are confirmed by this measure.

Area code	$H$
001	1.317
002	1.001
003	1.134
004	0.482
005	0.863
006	1.267
007	1.174
008	1.318
009	0.689
010	1.226
011	1.190
012	0.460
013	1.021
014	0.852
015	1.262
016	1.171
017	1.345
018	1.069

Tab. 2 - Shannon entropy values ( $H$ ) for the 18 urban areas: evaluation of the spatial coherence.

## 6. Conclusion

To develop the interpretation of our results through the reference to the information theory, we mention that the Shannon entropy is basically a measure of the amount of information. In this way, the information is synonymous with unpredictability: a totally unpredictable, original message has a maximum of information (a high value for  $H$ ) but appears messy, complex and unintelligible. Conversely, a message with few information (a low value for  $H$ ) appears as predictable, repetitive, orderly and intelligible [27]. As part of our research, we can consider the entropy  $H$  as an indicator measuring the spatial coherence. The two categories of messages described above find a match with the urban fragments with the least consistency (such as the fragment No. 17 corresponding to the heterogeneous city entrance) and those that appear as homogeneous and coherent (streets and squares which content only two different chromatic types).

Finally, we can notice that some urban areas of the historic center have a high value for  $H$ . This is for example the case of the fragment No. 1 which is one of the oldest streets of Liège (Rue Hors-Château). The restoration of the facades of that street required the use of many different shades of mineral coatings coupled with natural stone, which multiplies the number of apparent colours. In this specific case, the perceived spatial coherence is mainly due to the homogeneity of the urban form of the buildings which have similar shapes. For this reason, it would therefore be interesting to develop a global approach that would also integrate the spatial coherence considering the homogeneity/heterogeneity of the urban form.

## References

- [1] Kahn G., "L'Esthétique de la rue", Gollion: Infolio éditions, 2008.
- [2] Lynch K., "L'image de la Cité. Paris: Dunod", 1999. "The Image of the City", The MIT Press, translated from the English.
- [3] Koolhaas R., Mau B. , "SMLXL", New York: The Monacelli Press, Second edition, 1998.
- [4] Minah G., "Colour as Idea: The Conceptual Basis for Using Colour in Architecture and Urban

- Design”, *Colour: Design @ Creativity* (2) 2008, 3, pp. 1-9.
- [5] Collette JP., Nguyen L., “Couleur et pratiques urbanistiques”, *Les Cahiers de l’Urbanisme* 2006, 59-60, pp. 70-75.
- [6] Ameri A., “Architecture Pedagogy, Cultural Identity, and Globalization”, *The International Journal of the Arts in Society* 2008, 2(6), pp. 45-54.
- [7] Chin S., “Colour Scheme Supporting Technique Based on Hierarchical Scene Structure for Exterior Design of Urban Scenes in 3D”, *Color Research & Application* 2010, 37(2), pp. 134-147.
- [8] Lenclos JP., Lenclos D., “Couleurs du monde: géographie de la couleur”, Paris: Ed. Le Moniteur, 2003.
- [9] Garcia-Codoner A., Llopis Verdú J., Torres Barchino A., Villaplana Guillén R., Serra Lluch J., “Colour as a Structural Variable of Historical Urban Form”, *Color Research & Application* 2009, 34(4), pp. 253-265.
- [10] Ministère de la Région Wallonne – Direction de l’Aménagement du Territoire, du Logement et du Patrimoine – Division de l’Aménagement et de l’Urbanisme. Coordination et maquette : Professeur Albert Dupagne. Etudes et Documents. Aménagement et Urbanisme 2. “L’espace public de la modernité”, Jambes, Belgique: Danielle Sarlet, 1997.
- [11] Corboz A., “L’urbanisme du XXe siècle : esquisse d’un profil. Le territoire comme palimpseste et autres essais”, Paris, France: Les Editions de l’Imprimeur, 2001.
- [12] Hanin Y., “De la ville étalée à la ville éclatée”, *Les Cahiers de l’Urbanisme* 2007, 63, pp. 32-36.
- [13] Mongin O. “La condition urbaine. La ville à l’heure de la mondialisation”, Paris, France: Editions du Seuil, 2005.
- [14] Bruyns G., “Urban fragmentation vs. Spatial Coherences”, Paper delivered at the World Congress on Housing, XXXII IAHS, Transforming Housing Environments through Design, September 27-30, Pretoria, South Africa.
- [15] Allain R., “Morphologie urbaine. Géographie, aménagement et architecture de la ville”, Paris, France: Armand Colin, 2004.
- [16] Salinger N.A., “Complexity and Urban Coherence”, *Journal of Urban Design* 2000, Vol. 5, No. 3, pp. 291-316.
- [17] Gibout C., “Les entrées de ville : une affaire de commerce ou d’hospitalité”, *Les Annales de la Recherche Urbaine* 1998, 78, pp. 109-113.
- [18] Mangin D., “La ville franchisée. Formes et structures de la ville contemporaine”, Paris, France: Editions de la Villette, 2004.
- [19] Nguyen L., Teller J., Reiter S., “Chromatic mutations in suburban areas”, in: Lee TR, Shyu J, editors. AIC 2012, Color & Environment: In Color We Live, Interim Meeting of the International Color Association, Taipei, Taiwan, 22-25 September 2012. Book of Abstracts. Conference Proceedings on CD. Taipei: Color Association of Taiwan, 2012. pp. 20-23.
- [20] Nguyen L., Teller J., “Color in the urban environment: A user-oriented protocol for chromatic characterization and the development of a parametric typology”, *Color Research & Application* 2016, doi: 10.1002/col.22022.
- [21] Yendrikhovskij SN., “A Computational Model of Colour Categorization”, *Color Research and Application* 2001, Supplement Volume 26, pp. S235-S238.
- [22] Gil J., Beirao JN., Montenegro N., Duarte JP., “On the discovery of urban typologies: data mining the many dimensions of urban form”, *Urban Morphology* 2012, 16(1), pp. 27-40.
- [23] Burger W., Burge MJ., “Principles of Digital Image Processing – Core algorithms”, Undergraduate Topics in Computer Science, Hagenberg, Austria /Washington DC, USA: Springer, 2009.
- [24] Courbières C., Fraysse P., “Langage de l’architecture / architecture des langages : construction du sens dans le vocabulaire architectural”. In *Intelligence collective et organisation des connaissances. Actes du 7ème Colloque du chapitre français de l’ISKO*: Lyon, 2009, pp. 239-248.
- [25] Summerson J., “Le langage classique de l’architecture”. Edition revue et augmentée. Traduit de l’anglais par Bonne B. et Bonne JC sous la direction de Mauriès P. Paris, France: Thames & Hudson, 1992.
- [26] Zevi B., “Langage moderne de l’architecture”. Paris, France: Dunod, 1991.
- [27] Moles A., “Théorie de l’information et sémantique”. *Les cahiers de la publicité* 1963, 5, pp. 15-36. [http://www.persee.fr/web/revues/home/prescript/article/colan\\_1268-7251\\_1963\\_num\\_5\\_1\\_4795](http://www.persee.fr/web/revues/home/prescript/article/colan_1268-7251_1963_num_5_1_4795).
- [28] Pavoine S., Dufour AB., “Mesure de la biodiversité”. Fiche TD avec le logiciel R: tdr 28. Lyon, France: Université Claude Bernard Lyon 1 - Laboratoire de biométrie et biologie évolutive - Enseignement de statistique en biologie évolutive, 2015.

# Contemporary residential streetscape: how colors and material differ from the traditional streetscape. A case study in Tokyo

<sup>1</sup>Lorena Alessio

<sup>1</sup>Dept. of Architecture and Design, Politecnico di Torino, lorena.alessio@polito.it

## 1. Nature, sensations and colors

Traditional Japanese colours' origin and meanings derive from a very unique aesthetics, which was developed in Japan through centuries. Japanese culture is embedded by local Shinto, but was also influenced by Chinese and Buddhist philosophies. In fact, Japanese culture is characterized by periods in which foreign cultures entered into the island and others, in which the country was closed to the outer world. Those enclosed periods were fundamental for the creation of the specificity of Japanese aesthetics, which influenced arts and the view of the world.

Shinto brought a strong sense of the importance of being in harmony with nature. In Shinto nature is strictly connected to spirit. Each natural element has its own god *kami* (神), a "soul". Flowers and animals, rocks and rivers, bays and islands possess their own and autonomous spiritual life (Calza, 2004). Thus, relationship between man and nature is quite different from the Westerners, because Japanese people feel the need to be immersed into nature. By feeling nature, people get closer to the spiritual world.

Nature is loved with its cycle and seasons. Buddhist philosophy enhances the perception of things in nature. For instance, *Mono no aware* (物の哀れ) is the concept describing the ephemeral beauty of things in nature. *Aware* means "feeling" but also "sadness", and *mono* means "things". It is about the attention and admiration for what is flowing and irreversible, it is about a melancholy feeling and loneliness, about acceptance of transience. Thus, perception of space in Japan is connected to time and seasons being the transience of things deeply rooted into the Japanese culture and tradition. Coming to colors, the Japanese color world is a direct expression of the Japanese culture. Thus, it is not surprising that most of *dentouiro* (伝統色), the traditional colors, have names deriving from nature. Names are depicting colors from flowers and plants in all different seasons, and also from birds and rocks. Nowadays, we can count around 500 names for traditional colors. In Figure 1 the chart represents a Red Series of them. We could say that the chart refers to traditional colors as in Japan in Edo period, as well referred by Sachio Yoshioka (2014).

Colors in nature have many different hues, and they can change based on sunlight and climate conditions. Especially, spring and autumn are seasons in which Japanese can appreciate the variety of colors, such as the famous and beautiful views of mountains in fall with red leaves from maple trees, as in Figure 2.

Traditionally, also the moon was highly considered as creating beautiful and special colors, reflections and atmospheres. Names of colors define those different atmospheres.

## Red Series [ edit ]

Name	Romanized	English translation	RGB	Hex triplet	Name
鴉羽色	Tokiha-iro	Ibis wing color	245,143,132	#F58784	桜鼠
長春色	Chōshun-iro	Long spring (season) color	185,87,84	#B95754	唐紅/韓紅
蘇脂色	Enji-iro	Cochineal red/rouge	157,41,51	#9D2933	深緋
甚三紅	Jinzamomi	Thrice-dyed crimson	247,102,90	#F7645A	水がき
梅鼠	Umenezumi	Plum-blossom mouse	151,100,90	#97645A	蘇芳香
赤紅	Akabeni	Pure crimson (dye)	195,39,43	#C3272B	真朱
小豆色	Azuki-iro	Red bean color	103,36,34	#672422	銀朱
海老茶	Ebicha	Maroon (Shrimp brown)	94,40,36	#5E2824	栗梅
曙色	Akebono-iro	Dawn-color	250,123,98	#FA7962	珊瑚色
猩々緋	Shōjōhi	Red-orange (lit. orangutan-colored)	220,48,35	#DC3023	芝翫茶
柿渋色	Kakishibu-iro	Persimmon-juice color	147,67,55	#934337	紅樺
紅鷲	Benitobi	Red kite (bird species)	145,50,40	#913228	紅檜皮
黒鷲	Kurotobi	Black kite (bird species)	53,30,28	#351E1C	紅緋
照柿	Terigaki	Glazed persimmon	211,78,54	#D34E36	緋
江戸茶	Edocha	Red-brown (Edo brown)	161,61,45	#A13D2D	紅柄色
檜皮色	Hihada-iro	Cypress bark color	117,46,35	#752E23	宍色
洗朱	Araishu	Rinsed-out red	255,121,82	#FF7952	赤香色
ときから茶	Tokigaracha	Brewed mustard-brown	230,131,100	#E68364	黄丹
蘇比	Sohi	Overdyed / refreshed red-brown	227,92,56	#E35C39	遠州茶
嚙茶	Karacha	Spicy red-brown (Chinese tea brown)	179,92,68	#B35C44	嚙茶
宗傳唐茶	Sōdenkaracha	Faded spicy red-brown	155,83,63	#9B533F	雀茶
栗皮茶	Kurikawacha	Chestnut-leather brown	96,40,30	#60281E	百塩茶
鳶色	Tobi-iro	Ibis-color	76,34,27	#4C221B	

Fig. 1 – Red Series of traditional Japanese colors chart.  
([https://en.wikipedia.org/wiki/Traditional\\_colors\\_of\\_Japan](https://en.wikipedia.org/wiki/Traditional_colors_of_Japan))



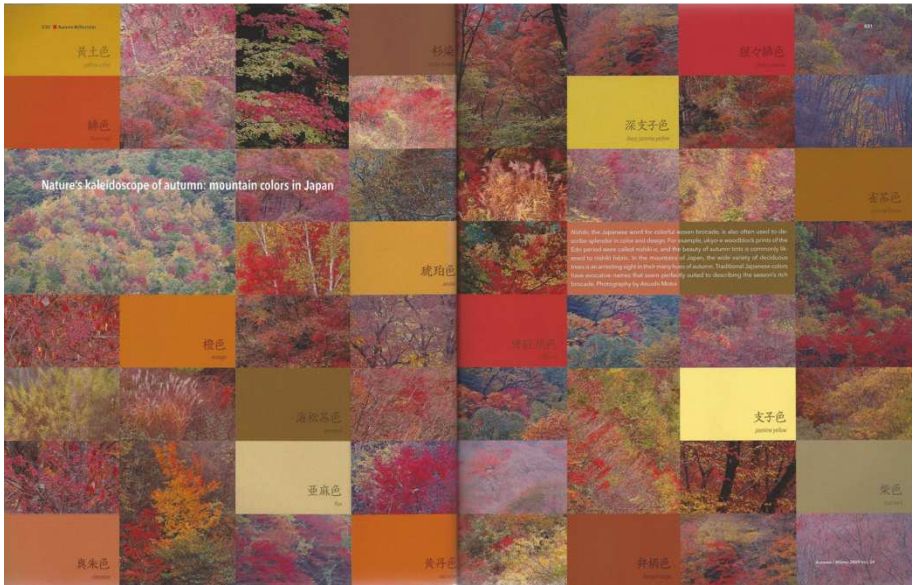

Fig. 2 – Nature's kaleidoscope of autumn: mountain colors of Japan. (Kateigaho, International Edition, Vol. 24, pp. 23-24)

## 2. Japanese traditional streetscapes

At the end of the XIX century, first Westerners who visited Japan found Japanese cities and architecture too simple and without ornaments. Edward Morse appreciated and understood Japanese culture, declaring its differences from the American architecture and cityscape. And when describing Tokyo' streetscapes he affirms "... Japanese house is... unsubstantial in appearance, and there is a meagerness of color. ...Where external walls appear they are of wood unpainted, or painted black; and if of plaster, white or dark slate colored. In certain classes of buildings the outside wall, to a height of several feet from the ground, and sometimes even the entire wall, may be tiled, the interspaces being pointed with white plaster." (Morse, 1990: 6-7).

Mainly, traditional architecture is built out of wood. Wood is left unpainted.

In the built environment, natural materials kept their original colors and features. The finishing of materials should emphasize the material peculiarities or irregularities. Among elements of beauty we can find the irregularity of materials, and their textures. Thus, wood is appreciated in its veins and torsions; rocks in their peculiar shapes. A traditional Japanese house was designed for looking at the landscape and the changing of seasons. Interior spaces were characterized by warm and consistent atmosphere, based on subtle variations of intensity and gradation of few colors connected to colors of wood and earth.

When writing about traditional Japanese architecture and aesthetics principles, Atsushi Ueda (1990), Sachio Yoshioka (1999) and Mira Locher (2015) underline the consciousness of the use of few colors in architecture.



Fig. 3 – Kanazawa – Samurai Residences Streetscape.  
(Photo by the Author)



Fig. 4 – Kyoto –Gion Area Streetscape.  
(Photo by the Author)



Fig. 5 – Takayama - Old Streetscape.  
(Photo by the Author)



Fig. 6 – Takayama - Old Streetscape.  
(Photo by the Author)



Fig. 7 – Kyoto - Facades in Gion Area.  
(Photo by the Author)



Fig. 8 – Above: Utagawa Kuniyoshi. “Kasumigaseki”. Series: Famous Places of the Oriental Capital (Edo).  
 (in Ukiyo-e. Il mondo flottante, p. 318)

**NAME ROMANIZED ENGLISH**  
 in the traditional color chart:

**RGB** ↓

Right side:



1. 藍白 Aijiro Indigo white 235, 246, 247



2. 墨色 Sumi-iro Ink color 39,34,31

Left side:



3. 銀鼠 Ginnezumi Silver-grey 151,134,124



4. 黄朽葉 Kikuchiba Golden fallen leaves 226,156,69



5. 藍白 Aijiro Indigo white 235, 246, 247

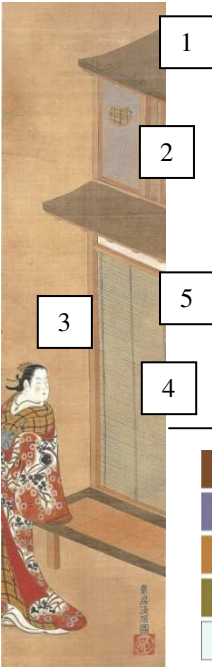

**NAME ROMANIZED ENGLISH**  
 in the traditional color chart:

**RGB**



1. 銀煤竹 Kinsusutake Golden-grey bamboo 125,78,45



2. 紅碧 Benimidori Stained red 120,119,155



3. 黄椽 Kitsurubami Golden oak 187,129,65



4. 苔色 Koke-iro Moss color 139,125,58



5. 藍白 Aijiro Indigo white 235, 246, 247

Fig. 9 – Torii Kiyonobu I. “Courtesan in front of a Tea House”  
 (in Ukiyo-e. Il mondo flottante, p. 341)

Colors are generally the colors of natural materials which are used in construction. Zen strongly influenced Japanese aesthetic concepts. Among the most loved ones: *wabi*, simplicity and poverty expressed through extreme synthesis of forms, *sabi*, the coat showing the passage of time in all things and *yugen*, the subtle incantation of things which cannot be expressed through words. The quality of material, the uniqueness of what it is used for a specific site are crucial qualitative values. Thus, as said, if a piece of wood is curved and it presents peculiar texture, then it will be used emphasizing its natural properties.

In traditional Japanese architecture, the built urban landscape in streetscapes appeared quite homogeneous, providing a strong visual identity to space.

A traditional streetscape presents few colors, mainly ranging among brown, grey and black tonalities. In existing historical areas of Japanese cities we can still visualize those characteristics, even if changing according to the locations and styles (refer to Figures 3 to 7). In traditional art, we can find views of streetscapes, which resemble the Morse's description of Edo.

In Figures 8 the Utagawa Kuniyoshi's Ukiyo-e represents the street view of Kasumigaseki in Edo (the old Tokyo). And in Figure 9, "Courtesan in front of a Tea House" by Torii Kiyonobu I, the tea house has a more colored façade, with blue colored plaster. The colors of the buildings depicted in Figures 8 and 9 have been associated with the traditional colors palette, as referred at the Japanese traditional colors chart ([https://en.wikipedia.org/wiki/Traditional\\_colors\\_of\\_Japan](https://en.wikipedia.org/wiki/Traditional_colors_of_Japan)), with names and RGB (see page 5).

### **3. Contemporary residential streetscapes**

Nowadays, most of the Japanese residential areas are composed by a vast number of single house buildings. Housings are located one next to the others, being separated by very narrow spaces (the minimum space ranges between 50 to 100 cm). Few areas are left for outdoors, but nevertheless greenery finds its place.

Housing's forms can be various, but when coming to colors they tend to present variations among grey and brown colors.

In most of the newly built houses' environment the actual tendency is even stronger, in showing very few colors in façades: large façades are white (as visible in Figures 10 and 11). The newest pamphlets advertising new housing settlements denote a tendency to wide and white façades (as in Figure 12). Colors are present thanks to plants and flowers located in front of the houses: the pamphlet at Figure 12 denote a late cherry blossoming in spring days.

Japanese people tend to personalize their settings through the use of plants, small vases in which continuously they change flowers and arrangements. Those flowers, area selected at seasons. Colors change accordingly. Those vases, mainly located at the houses' entrances, are positioned at various heights, to be easily visible at ground floor level. Vivid colors are there, in small spots, combined together according to the inhabitants' own taste and sensibility (see Figures 17 to 20).

Regarding the built environment, Figures 13 to 16 an analysis on-site show the main colors in facades. A chart of traditional Japanese color samples was used for comparison on-site.



Fig. 10/11 – Kamisaginomiya – Tokyo. Residential Streetscape.  
(Photo by the Author)

洗練のモダンデザインレジデンス  
「DIANA HOUSE 富士見台」誕生。

DIANA HOUSE  
ダイアナハウス 富士見台

NEW YEAR CAMPAIGN  
ニューイヤーキャンペーン  
1/16(土)・17(日)

新築表

西武建設  
「富士見台」  
駅徒歩 8分

1/16(土)・17(日)より  
いよいよ内覧会開催!  
— 同時先着順受付中 — <予約制>

建物面積 /  
100.46㎡-100.56㎡  
6,580万円

ご案内のご予約・資料請求・お問い合わせ  
0120-055-521  
受付時間 10時～18時  
ダイヤルワンストップ 検索 MORI OTO

日当たり良好 接道幅 8.3m以上  
最大 22.7帖 ゆどりのLDK

Fig. 12 – Pamphlet promoting new single housing in a contemporary residential area in Tokyo.  
(Diana House)



Fig. 13/14 – Residential buildings Façade in Kamisaginomiya - Tokyo.  
(Photo by the Author)

↓

	NAME	ROMANIZED ENGLISH in the traditional color chart:	RGB
	1. 利休鼠	Rikyūnezumi	Greyish dark green 101,98,85
	2. 瓶覗	Kamenozoki	Inside of a bottle 198,194,182
	3. 藍白	Ajjiro	Indigo white 235, 246, 247

↓





	NAME	ROMANIZED ENGLISH	ENGLISH	RGB
	1. 藍鼠	Ainezumi	Mousy indigo	92,84,78
	2. 鳥の子色	Torinoko-iro	Eggshell paper	226,190,159
	3. 白鼠	Shironezumi	White mouse	185 161 147



Fig. 15/16 – Residential buildings Façade in Kamisaginomiya - Tokyo.  
(Photo by the Author)

↓	NAME in the traditional color chart:	ROMANIZED	ENGLISH	RGB
	1. 素鼠	Sunezumi	Plain mouse	110,95,87
	2. 蒸栗色	Mushikuri-iro	Steamed chestnut	211,177,125
	3. 鳥の子色	Torinoko-iro	Eggshell paper	226,190,159



↓	NAME in the traditional color chart:	ROMANIZED	ENGLISH	RGB
	1. 素鼠	Sunezumi	Plain mouse	110,95,87
	2. 蒸栗色	Mushikuri-iro	Steamed chestnut	211,177,125
	3. 白鼠	Shironezumi	White mouse	185,161,147



Fig. 17/18/19/20 – Use of green in front of residential buildings in Kamisaginomiya - Tokyo.  
(Photo by the Author)

#### 4. Materials

Comparing to traditional housing, nowadays typologies and construction techniques are completely changed. Materials as well. Housing facades present different cladding according to the construction's period.

It goes from wooden material to plaster, from tiles to plastic. Nowadays, a major tendency it could be found in the use of printed plastic materials, resembling natural materials, such as bricks and stones. Figures 21 to 36 illustrate materials' images and colors.

#### Wooden Materials and natural colors.



Fig. 21/22 – Wooden facades' details in Kamisaginomiya - Tokyo.  
(Photo by the Author)



### **Plaster finishing and colors.**



Fig. 23/24/25– Facades' details. Plaster finishing - Kamisaginomiya - Tokyo.  
(Photo by the Author)

### **Polished concrete and natural color.**



Fig. 26– Facades' details . Concrete.  
Kamisaginomiya – Tokyo.  
(Photo by the Author)

### **Bricks walls (especially as fences).**



Fig. 27– Facades' details in bricks.  
Kamisaginomiya – Tokyo.  
(Photo by the Author)

### **Facades in tiles.**



Fig. 28/29/30/31/32/33- Facades' details. Tiles cladding - Kamisaginomiya - Tokyo.  
(Photo by the Author)

### **Facades in printed plastic imitating natural materials.**



Fig. 34/35/36- Facades' details. Cladding in plastic- Kamisaginomiya - Tokyo.  
(Photo by the Author)

## 5. Conclusion

At first glance, residential streetscapes in Japan look monotonous and lacking of a strong identity. Those settlements define large parts of Japanese cities. Comparing to traditional streetscapes it is possible to notice a lack of order in facade composition, and a growing tendency in using artificial materials for cladding. The plastic materials used for cladding barely reproduces textures of natural ones. The use of plastic is justified by its low costs and easy maintenance: *sabi*, the coating on materials defined by the passage of time is not anymore a value. Regarding colors, the tendency to avoid vivid colors is still present. Moreover, colors just resemble the faked materiality of wood, stone or brick. It is not always possible to refer colors to traditional ones. In further studies the definition of traditional and contemporary colors should be explored and questioned. The relation with nature is kept through the plantations on small spots of land facing the houses. Flowers accurately change according to seasons and from trees' blossoms. Those trees have been chosen to be alternately blooming in different moments of the year. With movable objects such as vases, inhabitants express their personal taste and sensibility choosing flowers and arranging them. The attention to seasons and colors that traditionally was also visible in clothing and especially in kimono's wearing, nowadays is exclusively visible in the small gardens' arrangements. The built environment is waiting to be en-lighted by colors of nature, offered by the small and ever changing green spots. The present study is still very wide. It focuses on several issues. It regards colors in urban life. The research would be further conducted on studies about:

- the notions of the traditional Japanese color world;
- the definition of "traditional colors" and "contemporary colors";
- the notion of color in urban life, with analysis of nomination of colors, the color of clothing, the urban coloring, and deepening the analysis on the exterior architecture as well as gardens.

## Bibliography

- [1] G.C. Calza, "Ukyoe. Il mondo fluttante", catalogo mostra, Mondadori Electa, Milano, 2004
- [2] S. Murasaki, "La storia di Genji", Einaudi, Torino, 2015
- [3] E.S. Morse, "Japanese homes and their surroundings", Ticknor and Co, Boston, 1886  
n.e. Charles E. Tuttle Company Inc., Rutland, 1990
- [4] L. Ricca, "La tradizione estetica giapponese", Carocci, Roma, 2015
- [5] L. Dalby, "Kimono. Fashioning Culture", Vintage, London, new ed., 2001
- [6] S. Matsuoka, "Origins of a Reflective Culture", p. 39-53, Kateigaho, International Edition, Debut Issue, Autumn 2003, Tokyo, Sekai Bunka Publishing Inc.
- [7] S. Miyake and S. Iida, "Autumn Reflections", p. 14-31, Kateigaho, International Edition, Vol. 24, Autumn/Winter 2009, Tokyo, Sekai Bunka Publishing Inc.
- [8] M. Locher, "Japanese Architecture: An Exploration of Elements and Forms", Tuttle Publishing, North Clarendon, 2015
- [9] A. Ueda, "The Inner Harmony of Japanese House", Kodansha International, Tokyo, 1990
- [10] S. Yoshioka, "Kyōto machiya iro to hikari to kaze no dezain"/ 京都町家色と光と風のデザイン / 吉岡幸雄", Kodansha, Tokyo, 1999
- [11] S. Yoshioka, "12 months of colors in Japan"/ 日本の色の十二カ月について, Shikosha, Tokyo, 2014
- [12] <http://www.tofugu.com/2013/09/12/the-traditional-colors-of-japan-making-modern-history/>
- [13] <http://www.colordic.org/w/>
- [14] <http://www.temarikai.com/CulturePages/TradJapaneseColors.html>  
[http://en.wikipedia.org/wiki/Traditional\\_colors\\_of\\_Japan](http://en.wikipedia.org/wiki/Traditional_colors_of_Japan)

# Chromatic experiences: from the territory to the industry

Lina PERDOMO

Colorist Designer, PhD student at the University Toulouse Jean Jaurès, FRANCE, [lina.perdomo@etu.univ-tlse2.fr](mailto:lina.perdomo@etu.univ-tlse2.fr)

## 1. Introduction

This paper aims to share preliminary results of an ongoing research project about the impact of contemporary creative methods used in the process of color invention in the paint and coatings industry in Latin America.

According to the French sociologist Michel Liu (1997), the notion of invention (*from the latin inventus, in- (inwards), ventus (venire= to come)*) as a "search for new possibilities", becomes the conceptual center of this action-research experience. This notion of invention will lead us to a way where designing new creative methods becomes a process of dynamic reconstruction that must be validated not only through observation but also through experimentation and actions proposed by a creative actor: the colorist designer.

Thus, the objective of this research does not consist in standardizing the color invention methods applied in this industry today, but to better understand these processes to be able to propose new approaches based on the artistic expertise of the colorist designer. We investigate all of this through the development and the implementation of colorist designer methodologies such as type color (*contretypage*), color sample tests, chromatic cartographies, ethnographic methods, among others, from the fields of color anthropology and artistic poetics. The continuous absence of this creative actor today raises the question: Is it possible for the industry to innovate in the process of color invention without the constant cooperation of a color specialist from the field of applied arts?

*"Invention in poetics, [is defined as] the first phase of the creative process. That phase of readings, during which materials are combined and arguments are organized<sup>1</sup>",* represents each connection established within a creative process that transforms into every phase of the research. Beyond these connections, the experience in the Latin American territory as an "open process<sup>2</sup>" refers to a set of activities in which there are various possibilities of creation and invention. Therefore, in the chromatic experience, chance and certainty continuously appear as random and contradictory feelings in the development of this practice. This can certainly be attributed to the connections explored by the colorist designer in cooperation with other color experts having different approaches, such as chemical engineers, business managers and designers, who constitute the center of exchanges that influence the decisions during each phase of the development of creative methods.

That being said, during his chromatic experience, the colorist designer as an actor from the field of applied arts assumes the position of a translator. At this point it is important to emphasize the value of appreciating his artistic sensitivity in the field of color creation in Europe. His sensitivity together with the industry codes will be nourished by social interactions for the development of future approaches for the

---

<sup>1</sup> Lecerf, G., (2013) Le répertoire de couleurs d'Henri Dauthenay: mémoire et imagination à l'oeuvre. *Primaires* (N° 173) p. 47

<sup>2</sup> Liu, M., *Fondements et pratiques de la Recherche-Action*, Paris : L'Harmattan, 1997, p. 119

creation of new colors for the industry. Such is the case that his specific perspective puts us in a context where dialogue constitutes an essential tool in our questioning of industrial processes in Latin America. This process of questioning is partly based on a fiction initially built at a distance. We have chosen the term fiction, "*not because [fictions] are misleading, but they express a social imaginary*"<sup>3</sup>. Thus, this social imaginary that is found in the exchange between cultures, the confrontation of different perspectives, the discussions about the relations between the author's research notes and color symbolization processes accompany this study.

Based on a poetic experience, this study is supported by an observational study and a photographic practice, introducing the chromatic analysis of a journey through the capitals of Colombia (*Bogotá D.C.*) and Panama (*Panama City*).

To sum up, based on data collected during these journeys around both cities and an ethnographic experience in the color industry, this article is structured into three different main parts. At each stage the different objectives of the visits to the territory are identified. In addition, the interest of the engineering and color marketing areas, towards the understanding of the colorist designer's everyday practice in Latin America is exposed. In this regard, the first part focuses on the poetic and chromatic experience of the colorist designer placed inside the territory. Subsequently, the results of an ethnographic survey conducted in the paint and coatings industry are presented, revealing the influence of different professional categories and also of active members as continuous participants in the selection of territorial colors. The third part shows how the first conclusions drawn from this intercultural experience become an important factor in the poietic of the colorist designer.

The article finishes with a discussion and conclusion about the progress of the research and the next steps to follow in the process of data analysis.

## 2. Poetic experience in the field

During the first part of the author's poetic experience and after several years of not visiting Colombian and Panamanian territory, everything that memory and imagination had retained from previous visits, was modified during the chromatic journey realized in the context of this research.

In this way, mentioning the notion of *experience*<sup>4</sup> as getting close to a subject from a distance, observing and acquiring knowledge, opening a door to a multitude of possibilities to the actor's creativity, one could say that being outside (*ex*) means activating our faculty to conceive ideas and turn them into projects. This involves acquiring the skill (*peritus*) to reconstruct scenarios, investigating a topic on a deeper level, learning things about our history that we did not know before. Being outside is coming back; it is to cross borders in order to witness the evolution of a chromatic identity, of whose appearance we were not aware before.

---

<sup>3</sup> Amossy, Ruth ; Herschberg Pierrot, Anne. Stéréotypes et clichés : Langue, discours, société. 3ème édition, Paris : Armand Colin, 2011, p. 29

<sup>4</sup> From the latin *experientia*, derived from *experiri*, «prove», from the verb *exp̄irō* « try, check », composed by the prefix « ex » - « outside». Related with the latin word *peritus* « expert, trained, skill » De raíz PIE \*per - « lead to, pass over ».

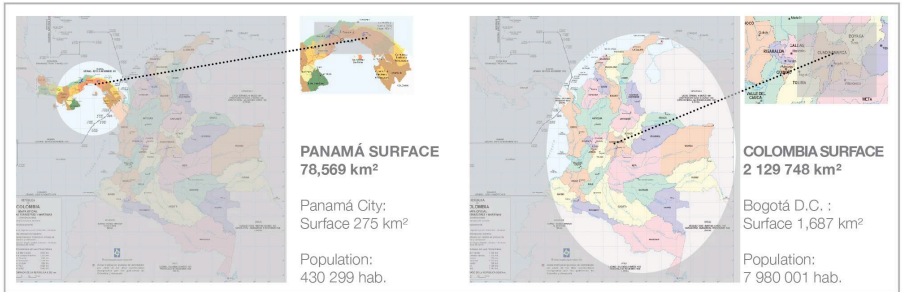

Fig. 1 Bogotá & Panama political maps

Following the introduction given by John Cage about color, this *"brings with it common experiences, [but it requires] an aesthetic intention to give it a true value<sup>5</sup>."* So much so that at the beginning observing, recording and photographing the city allowed the author to strengthen that intimate dialogue composed by the diverse architectural typologies that define the chromatic identity of the city. Color as a language is presented here, as a center of complex interactions within the urban territory. According to Michel Liu, *"Social reality is formed by interactions: behaviors, thoughts, communications, decisions, actions."*<sup>6</sup> Following this logic, a series of chromatic circuits appear throughout our journey, creating tensions and aesthetic connections that were intensifying as we moved forward through the streets of every city.

Studying Bogotá's chromatic identity in all its immensity constitutes a complex task. It would involve years of work and it would require a significant budget for our immersion into the field and subsequent data analysis. Given that time is one of our limitations in the first phase of this study, we will focus on our short exploration of the northern zone of the city, between the districts of Suba and Usaquén. Specifically, between the neighborhoods of *Cedritos* and *Pantanitos* located just 3km apart.

Our tour through Bogotá began in the neighborhood of *Cedritos* (located in the district of *Usaquén* - 147<sup>th</sup> St. 9<sup>th</sup> Av.). A neighborhood where the urban landscape is dominated by brick buildings, creating a strong presence of red *cameaux*, intensified by the agglomeration of structures close to each other. Moving down through the 9<sup>th</sup> avenue, we found small color traces, spread, hidden, and often in contrast with the environment. Beginning with whites and creams, these secondary colors of this area, hidden among the chromatic variety of the bricks are transformed into more vivid colors as we move forward. Heading towards *Pantanitos* (located in the district of *Suba*), we pass quickly through the *Madeira*, *Icata* and *Dardanelo* neighborhoods, where small buildings with similar characteristics, between 5 to 10 floors, gradually begin to adopt the color palette of this area. Yellows, blues and reds slowly appear in the urban landscape, to finally expose a neighborhood with a variety of traditional houses.

<sup>5</sup> Gage, J., *Couleur et Culture*. Paris : Thames and Hudson, 2008 p. 9

<sup>6</sup> Op. cit., Liu, M., p. 124

And it is there that our first impression of the territory has been modified. In this sector, mostly commercial, the bricks only appear as part of the facades of unfinished buildings. This material that defined in a first instance the chromatic identity of the neighborhood of *Cedritos*, is now usually covered by bright colors such as oranges, reds, yellows and blues, giving us the impression as if they had been chosen with the specific intention of intensifying the natural beauty of the territory.

This experience in the field leads us to say that the territory echoes its mountainous landscape. The geographical variety of the city's surroundings is mirrored by the variability of heights, types, shapes and an assortment of colors in the visited neighborhoods.



Fig. 2 Bogotá Chromatic tour - from Cedritos to Pantanitos

A similar situation has been encountered in Panama City. This time, the red bricks are not the ones that impact our vision, but huge white buildings between 30 and 80 floors high. They define the urban landscape since the turn of the century, symbolizing the building boom in this country. Panama City, the skyscraper city of Latin America, however hides behind this white immensity a polychrome urban landscape that we can only discover as we explore the popular and industrial sectors often hidden inside the city.

The route between *Costa del Este* (an upscale residential area) and *Las Mañanitas* (mostly an industrial area) illustrates this experience. During the immersion into these areas, the contrast of the "modern" city with *Las Mañanitas* had a strong sensory impact that led us to question ourselves about the complexity of the territory. The play of light and shadows generated by those large and white buildings that define the chromatic identity of the city in *Costa del Este*, turned into small and colorful houses surrounded by multiple green areas. In this neighborhood, mainly inhabited by the employees of industrial enterprises that are located in the area, white becomes a secondary color that only appears to highlight the balconies and windows of otherwise radiantly colored houses. Among the lemon yellows, royal blues, fuchsias or emerald greens of these facades, we question the territory's identity. In this way, the dialogue between the white with the bright colors of *Las Mañanitas* houses, creates a rupture between what our body, the architecture and the surrounding nature transmitted to us on a first sight.



Fig. 3 Panama Chromatic tour - from Costa del Este to Las Mañanitas

The concept of *coloris poetics* has been defined by Guy Lecerf as that “*which is imposed as a final stage. That one which keeps its distance from the material dimension, from the “atelier” and the construction site. That one that enables different experiences, like that one of an unfinished coloris*”<sup>7</sup>. During the explorations and immersions in the territory, this concept, as a “final stage” appears from the moment the colorist designer recognizes the connections created between a cultural complexity and his artistic sensitivity (involving nuances, textures and shapes). This being said, taking distance from the “atelier” as a place of analysis and action will enhance the possibilities to offer new creative methods to the processes questioned in this research.

Our experiences in both cities highlight both the diversity and complexity of urban chromatic landscapes. Moving from a chromatic experience where uniformity reigns, to another in which the chromatic multiplicity becomes a main exponent, contributes to the re-evaluation of the image of each city. Both, the observation analysis and interpretation of this chromatic diversity are the main fields of expertise of the colorist designer.

We propose as one of the core points of our research to apply results of our chromatic analysis of urban landscapes to extend existing methods of color invention in the paint and coatings industry, thereby moving from the realm of analysis to the realm of creation. This important step puts the colorist designer in the essential position of a translator between the different actors in the industry, and his intention to valorize the color expertise in the field.

In this context we decided to extend our understanding of existing creative processes in the industry, as presented in the following.

### 3. Ethnographic experience in the industry

Data collected mainly in cooperation with Pintuco Colombia, a leading company in the development, production on the paint and coatings market of Latin America will allow us to enrich the creative universe of the color practice as an essential inventive method within the industry. We evaluate the influence of different professional categories that regularly participate in choosing what at this point we refer to as “*territorial colors*”. In other words, those colors that are daily produced by a team of

<sup>7</sup> Lecerf, G., *Le coloris comme expérience poétique*. Paris : L'Harmattan, 2014, p. 27

specialists who, supported by modern technology, prescribe new colors in order to respond to and anticipate consumer demand.

Today, in the paint and coatings industry different prescription and color communication tools are designed in response to the needs of specialists in renovation, construction and decoration. However, the aim is also to satisfy the aesthetic needs of a society, while trying render these tools more accessible to creative actors from other domains, such as industrial designers, painters or sculptors.



Fig. 4 Actual color prescription & communication tools

I suggest at this point to understand the word *industry* in its most basic and comprehensive sense in order to deepen our understanding of the position color has as an omnipresent language in this whole process of creation and invention. The notion of industry is defined by the RAE (*Real Academia Española*) as a "set of material operations performed for obtaining, processing or transporting one or more natural products".

The fascination of this field for exploring and discovering new materials, pigments and processes involves awareness and responsibility for their use. For this reason the different factors involved in the development of a color formula, such as the point of view of the chemical expert and the effectiveness of the marketing expert in his intention to anticipate needs, leads us to the question: who is really the one who arbitrates this field?

During our visit in the laboratory and marketing areas, we have encountered a variety of specialists whose work consists in developing different strategies (autonomously and in teams) in color development. Observing their teamwork allowed us to identify what François Noudelmann designates "family resemblances", a philosophy of affinities present in the specialist's everyday practice. *"These beings who do not always look alike and sometimes lose their similarities in a given moment"*<sup>8</sup>, represent the ephemeral character of the cognitive links created between the colorist designer and his colleagues.

Moreover, with regards to the colorist designer's practice, the notion of invention in poetics encompasses the whole creative process. However, through the interaction with the other actors, we identified how in the industry this notion is rather defined as an action associated with technological progress. Passing from creating color

<sup>8</sup> Noudelmann, F., *Les airs de famille: une philosophie des affinités*. Essai, Paris : Gallimard, 2012, p. 14



formulas in a traditional, mainly a “manual” way, to prescribing colors using automated processes throughout the whole process, completely influences the vision of the chemical expert on their actions related to creation.

Currently, it is the responsibility of the marketing area to manage creative processes, transformation and color anticipation strategies, development of the final product and bringing it into the market. This equally implies having to coordinate - during the creation and communication stages - everything that is related to the development of the tools and approaches used in the process. Regarding this area, we also observe that their language “borrows”, in some way, various terms from psychology, sociology and business domains, creating strategies that accompany them during the development of their color campaigns, with the aim of anticipating and responding to the immediate consumer demand.

That being said, the analysis of color invention processes in the industry, being such an important subject, will be carried out before implementing new strategies. At that stage, the relationships arising from these new creative approaches should also be reflected in the product positioning in retail outlets and in the seller language. However, it is necessary to raise awareness of the importance of sharing opinions with the color designer so we could achieve to attribute new creative processes in which the intervention of this color professional provides new answers to the methods used today in the territory. In short, this ethnographic experience tells us that once the product is exposed to the final consumer, who arbitrates the field is not going to be the marketing director or the head of the color laboratory, but definitively the result of the collaborative work of a team.

#### **4. Designer colorist’s intercultural experience**

Participating in a color invention process involves reflecting about the observer’s culture, the color appearance of an environment, that coloris that permeates the city and accompanies us in the search for understanding color as a language.

As mentioned above, putting the colorist designer in the position of a translator, means that while he transcribes his poetic experiences through creative methods, some notions involved in his discourse, such as “appearance” or “regulation”, will concern an aesthetic and standardized reflection always related with the construction of new creative methods.

The ethnographic approaches currently used helped us to reinforce our intention for a better understanding of the notion of “appearance” and its relation with the image of a city. This reflection and the rules that this involves, turned an ethnographic experience of 2 weeks into an experience in which memory, imagination, observation and dialogue built a database, the interaction with the environment representing the main actor. We believe that the insights gained from these experiences in the field and the following analysis will allow us to propose new creative methods better adapted to the particularities of the territory and rooted in the colorist designer’s expertise. What is the purpose of the translation then, if not wanting to communicate to a standardized industry the possibilities generated from the colorist designer’s artistic sensibility?

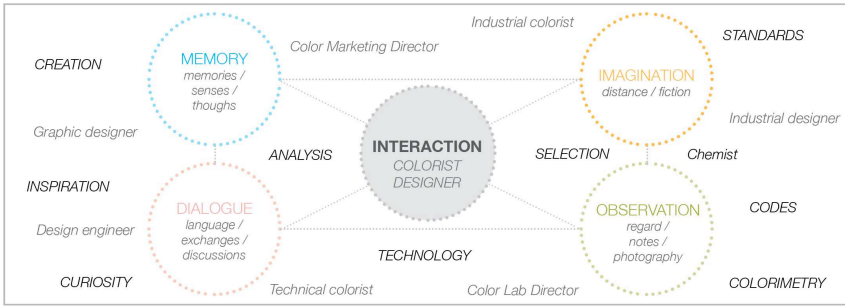

Fig. 5 Interactions: between creativity and normativity

According to René Passeron (quoting J. Pommier, 1946) poietics *"comprises on one hand the study of the invention and composition, the role of chance, of reflection, of imitation, of culture and the environment; on the other hand, the examination and analysis of techniques, procedures, tools, materials, media and action supports"*<sup>9</sup>.

We relate this definition to our reflection about color as a language and creative methods implicit in the development of this research. We could say that this work within the field of poietics adopts a system in which the chromatic journeys and the ethnographic surveys as mentioned above, would have as a fundamental purpose to transfer our poetic experiences into an industrial environment - a place where today the creative actor unfortunately occupies merely a minor position.

Furthermore, studying the chromatic construction processes means creating strategies to underline the static and dynamic color aspects for further analysis. In a further step, a common color language will be identified and evaluated experimentally in a dynamic group comprising actors from different areas of the industry are sought.

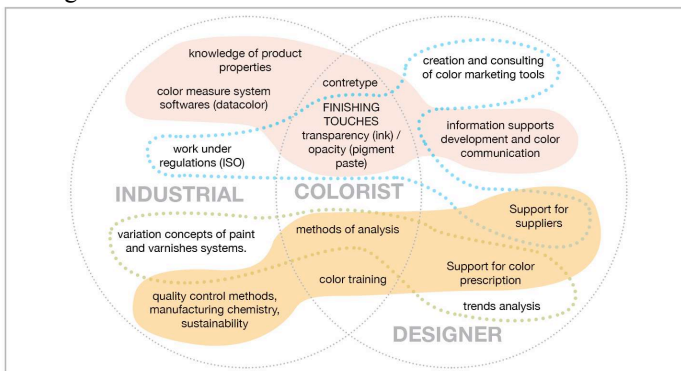

Fig. 6 Industrial Colorist & Colorist Designer (practice and connections)

Based on the information in the above figure (fig.6), it is possible to identify current connections between industrial and creative practices related exclusively by expertise on color. But even if the functions of the colorist designer in this field are mainly based on their sensitivity and their creative abilities in order to anticipate

<sup>9</sup> Passeron, R., Pour une philosophie de la création. Paris : Klincksieck, 1989, p. 14

consumer demand, his functions as well as those of the industrial colorist seems to place them both in a regulatory framework. The act of typing colors, identifying them, detecting them and (re) producing them, could only be turned into a common chromatic language in a collaborative process based on insights generated from this research.

Also, it is worth mentioning that the results of ethnographic surveys realized with Pintuco Colombia lead us to questioning what it means to develop analysis, classification and color prescription tools.

Through these tools that the colorist designer uses and invents in their daily activity, a large part of his role as a translator generates a dialogue with the consumer. Thus, tools such as color palettes, color samples and trend books are the ones who allow the consumer as an external actor to project themselves in their space.

## 5. Discussion and Conclusions

The analysis of our experience in Latin America was essential to identify the importance of using a common color language in the field of industry. The lack of fluency in this language in professional terms can limit the understanding of the other participants in the color invention processes and thus severely lowers the efficiency of communication processes inside the team.

At the same time, during the analysis of the actors' interactions, certain variations in relation to how they structure their internal social language were identified. In his publication about "role-plays", Alex Muchelli (1983) discusses different concepts and techniques used for therapeutic or personal and professional training purposes. The concept of role therefore appears as the most important concept in social psychology and it becomes a key notion in the next steps of this research.

The educational value of these games implicit in the variation of methods, in the adaptations to difficulties and in the structural model of itself, becomes a modifiable factor according to the aim of the activity. Based on the methodologies used within these group dynamics, the rules structuring the language, transform the data collected so that methods like the brainstorming or the study of social, professional and/or psychological roles, will make the relational experience within the working area easier. As a consequence, we are currently developing a collaboration proposal as a team strategy between art and science of engineering, where the concept of "group dynamics" is involved.

We add to the above that the notion of experience in the context of this investigation also involved a reflection about the imaginary world and the production capacity of the industrial sector. It should be noted that during the fiction constructed from our distance vision, what we would refer to at this point as "chromatic-plays" relates to what John Dewey described as "*extremely intense emotions [created] during the production process*<sup>10</sup>". From the definition of color, towards its transformation into a pigment or a dye and its production and arrival to the final consumer, these

---

<sup>10</sup> Dewey, J., *L'art comme expérience*. Traduit de l'anglais par Jean-Pierre Cometti, Paris : Gallimard, série : Folio essais, 2010, p. 66

"chromatic-plays" generate endless questions around the color translation from an artistic, sociological, psychological, physiological and archaeological point of view. During the creative process, translating a color must take into account the type of consumer whom the project targets and those involved in it. The colorist designer as a translator from his specialty and from his poetics experiences creates new connections between the actors in the field. He innovates in this way in different readings of a same color through the act of nomination for example, rebuilding his own poetic-chromatic language.

Referring to the colorist designer's language, talking about translation, this leads us to the stage of what we call *contretypage* (the fidelity of change, the passage from one universe to another, the encounter with the family resemblances). In this process of duplication, the image and the color become a unit in catalogs created for the customer. That is why we could talk about a chromatic cliché that creates social connections among consumers during these transfer process to achieve embedding poetry into everyday life. This reflection about the translation makes us think color as a unity within the multiplicity of this industrial practice. This is thanks to the identification of new work tools (smartphone apps, development of new color classification systems, adaptation to social networks) and the understanding of what the field demands (such as the desire and the need of "belonging" and adaptation to consumer demands), after living the experience in the territory and in this way being aware of the importance of using our poetic and ethnographic experiences in response to a set of requirements, imposed by normative structures and regulations.

Returning to the notion of invention, it represents at this point the different phases of a process where the development of a concept up to the product application in a given space, regroups a set of knowledge and standardized procedures in which the domain of imagination and the reality of an industry constrained by socio-economic interests are completely related. A problem that remains critical for the continuation of this analysis is the search for a definition of how the color conceived according to various factors becomes an actor of the industry - and how it could represent, from this role, the rupture between what is currently imposed on it by the industry and the pure intention of the colorist designer, to build new global color experiences. This will be achieved by translating economic, aesthetic and poetics needs implied by the preconceived conventions of any society.

It appears appropriate to also question the historical evolution and color perspective in the Latin American paint and coatings industry, which in almost 100 years (foundation of Grupo Orbis in 1921 - foundation of Pintuco Colombia in 1945) has shown a permanent and strategic evolution with a constant intention of adaptation to consumer demand.

Putting into perspective the place of color in creative methods related to its invention since the beginning of this industry, will certainly bring new ways of identifying the aesthetic intention and artistic sensibility of the different actors involved in this process. It would help us as well to understand why the immersion into the territory is essential in developing a knowledge that will bring new methodologies, able to offer a new insight into the industrial production of color.

Today the colorist designer must be willing to share and to understand from its position as a creative actor in the field of research, the different languages, the limits

and the benefits of its practice in order to participate in the creation of colors in the industry.

As for the question about the poetic experience, it is important to emphasize that our will to put poetry into our life through the immersion into the territory, will enable us to develop new methods during the action-research experience. Thus our main priority remains associated with the creation of new work models from the color design expertise. This will be a work realized with the intention of preserving not only the identity of a city, but to accompany the consumer in the process of identifying their uniqueness, and the chromatic and cultural links with their territory. In addition, different interpretations of the different modes of interaction and current creative methods to which we have referred, are not related to certain issues derived from the industry analysis, but to how appropriate or productive is the analysis of the process of color invention as a whole.

According to our first results, the paint and coatings industry has a very important task in the (re) construction of the chromatic identity of a territory. It opens the doors to the colorist designer who must reflect about it, to avoid lengthy creative processes that today give rather heuristic answers, precisely because of its continued absence in the sector. With all of this we wonder what really matters in the relationship between the industrial and creative sector, the outcome or the process.

From the colorist to the color, the colorist designer connects different points to mark the before and after in the color invention processes inside the sector. His artistic sensitivity implies awareness about the changes faced daily by the field of industry in relation to demand of the territory. A contribution of our research is to have succeeded in identifying that Latin American paint and coatings companies are aware of the evolution and the importance of exchanges in view of the development of new creative methods. Hence there is a need to keep focusing more closely on colorist designer practice so we can better understand his place in this industry in order to evaluate new working methods. At the same time we identified the importance of defining a chromatic language within the group of actors involved in the color development process, to finally be able to propose new possibilities within the multiple and varied ways of communicating color.

In this regard it is worth to keep questioning the position of the actors for the definition of new prescription tools and creative methods within the field of color. Besides, questioning the invention of color in more detail allows us to offer new solutions and compare them to approaches commonly used today by the industry, in order to create new forms of work organization. At last, we emphasize once again Michael Liu's position in relation to the Action-Research experience, which finally "not only aims to identify a problem, but to solve it. This, by implementing a change and thus use that solution as an experiment in order to obtain scientific knowledge."<sup>11</sup> The articulation between an artistic experience and a research practice, allows us in this way to anticipate responses to industrial development so we can continue inventing new communication color strategies.

---

<sup>11</sup> Op. cit., Liu, M., p. 163

## Acknowledgements

The author would like to thank *Pintuco Colombia* and *CIN Portugal* for their invaluable and useful information and also *l'Institut des Amériques* for their contribution to this project.

## Bibliography

- [1] Liu, Michel, *Fondements et pratiques de la Recherche-Action*, Paris: L'Harmattan, 1997
- [2] Lecerf, Guy, (2013) *Le repertoire de couleurs d'Henri Dauthenay: mémoire et imagination à l'oeuvre. Primaires (N° 173)* p. 44-49
- [3] Amossy, Ruth; Herschberg Pierrot, Anne. *Stéréotypes et clichés: Langue, discours, société*. 3ème édition, Paris: Armand Colin, 2011
- [4] Gage, John, *Couleur et Culture*. Paris: Thames and Hudson, 2008
- [5] Lecerf, Guy, *Le coloris comme expérience poétique*. Paris: L'Harmattan, 2014
- [6] Noudelmann, François, *Les airs de famille: une philosophie des affinités*. Essai, Paris: Gallimard, 2012
- [7] Passeron, René, *Pour une philosophie de la création*. Paris: Klincksieck, 1989
- [8] Dewey, John, *L'art comme expérience*. Traduit de l'anglais par Jean-Pierre Cometti, Paris: Gallimard, série: Folio essais, 2010

## **7. COLOUR AND DESIGN**





# Repetition of Color in the Nubian painting

<sup>1</sup> Ahmed Sahar, <sup>2</sup> Ragab Hoda

*1 Textile Printing, Dyeing and Finishing Department. Faculty of Applied Arts – Helwan University. Egypt, saharaim25@gmail.com*

*2 Textile Printing, Dyeing and Finishing Department. Faculty of Applied Arts – Helwan University. Egypt, Drhooda2013@hotmail.com*

## 1. Introduction:

Faras Cathedral was discovered in Nubia during the excavations carried out by the scientific and technical institutions in co-operation with UNESCO in the period from 1960 till 1970 to protect the monuments of Nubia which was flooded by the High Dam.

The importance of Faras Cathedral is shown in the mural paintings, which adorned the internal walls with extraordinary collection of colourful ornaments which have high artistic value. These paintings helped to identify what was lacking from the human knowledge about the Nubian culture and art, they also indicated a high level of Nubian culture in which the artist blends between his heritage over the past historical eras and what was present in his environment. This blend produced this collection which used repetition through various methods either in proportion, spread, distribution or direction and whether it is form or pattern on their own.

The research studies the features of mural paintings in Faras Cathedral, repetition of color in different artistic styles through various methods either in proportion, spread, distribution or direction.

## 2. Nubia :

Nubia is the name of the region that extends from Aswan in southern Egypt to the Debba city near Dongola in Sudan, the word Nubia have not been known until after the Ptolemaic era. The first document to mention the word Nubia was in Strabon's book *The Geography* that was written around 25 B.C. The ancient Egyptians called Nubia many names for instance Kunst or Tasty which means the country of holding archers.

Many different civilizations have passed by Nubia such as the ancient Egyptian, the Romanian, the Muriatic, the Byzantine (Christian) and the Islamic civilizations. All of these civilizations have had direct and indirect impact on the works of art produced by the Nubian people.

## 3. Faras Cathedral:

Nubia remained loyal the paganism until Christianity was spread there in the mid of the 6<sup>th</sup> century A.D., as a result most the Pharonic temples were turned into

churches and the walls were covered with thick layer of plaster and were used to paint the images of saints.\*

Churches have started to be built after a while in various cities .Faras was one of these cities that witnessed the built of a large church (cathedral) and it was called Faras Cathedral \*\*.This happened around the year (625 A.D. / 4 Hijri) when Nubia an Episcopal of the dioceses of Alexandria.

Faras Cathedral was burnt in the year (926 A.D. / 314 Hijri), however the bishops were able to save and renew it since (952 A.D. / 341 Hijri) starting with the bishop Elias then bishop Aaron .Afterwards bishop Petros adorned the cathedral with various mural paintings characterized by the dominance of the red color and the richness of the decorations.The interest in multi-coloured mural paintings with multi-dimensions increased with the presence of the bishop Ioannes and Marianous .This interest continued till the end of the 12<sup>th</sup> century A.D .6<sup>th</sup> century Hijri .The development kept going especially in the decorations that adorn the kings' and saints' clothes .These decorations were mainly multi-dimensional geometric forms and plant leaves' forms.

It is noted that Faras Cathedral has been decorated with coloured mural paintings (Fresco) in the form of white lime layers and plaster . Each layer represents the pattern or style that reflects the era and the art style. This is clearly depicted in the issues painted which have taken many forms; at first the paintings were characterized by the simplicity which is obvious in the paintings of The Madonna, Christ and the angels and saint.

Later on the paintings of Nubian kings and bishops started to appear on the mural walls .\*\*\*These paintings expressed the sovereignty of the king's authority .Such paintings showed more complex, beautiful, diverse and colorful designs, in addition to the themes in the Old and New Testaments as the birth and passion of the Christ, and the three youth in the furnace of fire .Yet the paintings of the Old and New Testaments were few in contrast with the personal paintings of kings, queens and bishops.

The discovery of the mural paintings in Faras Cathedral is considered an open gallery to the Christian (Byzantine) paintings .It illustrates the evolution of decorative patterns in the cathedral till the 15th century A.D .9th century Hijri . The credit to such discovery goes back to Professor Michalowski .The number of

---

\* Such as Wadi Elsiba'a temple, Amda temple and Abu Odeh temple, which retain their forms and decoration till now in their original colors - refer to Abdel-Moneim Abu Bakr : *Nubia*. p .75: 77.

\*\* Faras city is the capital of Nubia which is located in the northern part of Nubia . The kingdom of Nubia was merged with the Kingdom of El Makra and thus created a strong kingdom known as kingdom Dongola- Refer to Zain El Abideen :*The Art History of Nubian and Sudanese Jewelry* p .159.

\*\*\*14 paintings of bishops were found .The names of six of them have been identified .They are(Kyros, Kollutwos, Petros, Ioannes, Marianos, and Georgios) -Refer to Mr .Mohamed Gheitas' book *Painting in Nubia*, p .100.

the discovered items reaches a hundred and twenty pieces, half of this group is preserved in the Sudanese National Museum in Khartoum and the other half is in the possession of the National museum in Warsaw.

#### **4. The Features of mural paintings in Faras Cathedral:**

The features of mural paintings in Faras Cathedral are :

1 -The focus upon the main character in the painting either Nubian kings, Saints, Angels, The Christ, The Holy Virgin (or both together).

2- Only painting the characters in front position.

3- Drawing wide eyes which are called almond shape and straight nose.

4-Attention to ornaments and the multiplicity of their elements which were characterized by distinctive features that could be clarified in the following :

First :Using the geometrical elements, this greatly varied between lines and geometric shapes like the triangle, the circle and the square in addition to the Cross which has taken many forms individually or with other forms.

Second :Using the floral ornaments, especially roses which varied in many forms, shapes and sections of plant, also simple and abstract forms from natural resources

Third :Simple plaits .

Fourth :Peacock feathers .

Fifth :Distinctive usage of color, where each style was distinguished with specific colour or group of colours. Professor Michalowski divided these styles to five as following:

##### **4.1. Violet Style (8<sup>th</sup> century – middle of 9<sup>th</sup> century):**

In the oldest paintings the dominant colour is pale or dark violet, sometimes steel grays come to the fore. The development proper of the violet style continued throughout the 8<sup>th</sup> and early 9<sup>th</sup> centuries .

In the violet style the main element of the dress is the sticharion with two bands on the cuffs; the folds are indicated by violet and yellow stripes or, as in the paintings of the two archangels (**Fig.1,2**), the whole vestment is in a light shade of mauve. The vestments of the saints and apostles show a greater variety of ornamentation : semi – circles embroidered with seed pearls or the motif of spotted scales . the vestments of bishops are embroidered with precious stones in a square or circular setting. Sometimes, there are rosettes, or Maltese crosses on the stoles (**Fig .3**).

##### **4.2. White Style (second half of 9<sup>th</sup> century – first half of 10<sup>th</sup> century):**

The transition from the violet to the white style is best illustrated in the murals in the Apse (**Fig. 4**). the lower frieze (**Fig. 5**) composed of doves in arcades is painted in the violet tone with a strong addition of yellows, while the figures of the Apostles over the frieze are entirely in the white tone; the treatment of the robes are generally plain and shows the double pattern of folds .

In the white style, the robes are generally plain, but the stoles are decorated with more vivid colours, and the slippers are red (**Fig. 6**) .



Fig.1 Archangel Gabriel



Fig.2 Archangel Michael



Fig.3 Holy Arch Bishop



Fig.4 Painting in the Apse



Fig.5 Frieze with doves in arcades



Fig.6 Madonna with Georgios

#### 4.3. Yellow-red Style (10<sup>th</sup> century) :

In the 10<sup>th</sup> century the Yellow-red styles take over, best exemplified in Archangel Michael (Fig. 7), the dominant colour was definitely yellow . The red reigns supreme in the new paintings of the Cathedral done during the episcopate of petros (974-999A.D.) in (Fig. 8) which represented the portrait of Bishop Petros.

The coexistence of the yellow and red style of painting is most visible in two murals on the outside wall of the Cathedral at the south entrance . they are the Archangel Michael (Fig. 9), the Guardian of the Gate, a figure with a very threatening expression, and St Mercurius on horseback (Fig. 10) who pierces Julian the Apostate with his spear .

The composition of Archangel Michael is entirely in the yellow tone, whereas in the painting of St Mercurius on horseback the dominant colour is red.

The outer garments in Yellow-red Style have lattice pattern embroidery with seed pearls or precious stones painted at the interlacings.

The period from 8<sup>th</sup> to 10<sup>th</sup> century mark the gradual development of the motifs and ornaments 'design as well as enrichment of colouring.

#### 4.4. Multicoloured Style (first half of 11<sup>th</sup> century – end of 12<sup>th</sup> century):

The 11<sup>th</sup> century opened a new stage in the development of painting in Faras, for it was then that the full range of colours came into its own. An outstanding example of this new art, is the portrait of Bishop Marianos (Fig. 11) dated to the opening years of the 11<sup>th</sup> century.

The idealized rendering of the Madonna conforms to the binding style of representing saints. But the figure of Marianos has been treated as a realistic portrait of an actual man.



Fig.7 Archangel Michael



Fig.8 Bishop Petros protected by saint Peter



Fig.9 Archangel Michael



Fig.10 St Mercurius on horseback

In mid-12<sup>th</sup> century, this multi-colour style reached its peak. The artists were not only adept at working with a wide range of paints but also made use of various shades of colour to bring details into relief as seen, for instance, in the extant fragment of the Eparch fresco (Fig. 12).

In Multicoloured Style the lattice motif became not only an integral part of the outer garments but also appeared on the sticharion .

The decorative of Faras murals reaches the complexity in the period from the end of the 10<sup>th</sup> century up to the end of 12<sup>th</sup> century and the development of decorative elements is marked not in the motifs themselves but rather in a new, more free way of putting them together into a variety of ornaments and patterns (Fig. 13,14,15).



Fig. 11 Bishop Marianos under the protection of Madonna and child



Fig.12 Eparch



Fig. 13 Archangel Michael



Fig. 14 Cross with image of Christ and symbols of four evangelists

#### 4.5. Late Multicoloured Style (13<sup>th</sup> -15<sup>th</sup> centuries):

The last decorations preserved on the screen- like partitions are a telling proof of the decline of the great art of painting in Faras. The compositions preserved from those times lack the characteristics of the master's brushwork in the first half of the 12th century. The artists keep up the techniques achieved by their predecessors but they lack the dynamism, inventiveness in colour schemes and subtlety of modeling which were so characteristic of the earlier period (**Fig. 16**).



Fig.15 Madonna eleusa



Fig.16 King with a group of dignitaries

The decorative elements on Faras murals are very rich. They elements are composed of numerous motifs whose combination form sometimes very complicated ornaments and patterns, making the paintings contrast with the plain wall surface . In the 10<sup>th</sup> century the Nubian painters created their own school of painting, the most characteristic features of which were the decorative forms where the foreign elements transformed in a peculiar way formed local, specific only for Nubia, kind of ornamentation .

### **5.different repetitive patterns of Faras Cathedral:**

The repetition is the most important elements of composition in the artwork, especially in the formulation of decorative units and formations which consist of more than a single unit or form.

The definition of repetition is a re-doing the thing time after time; we considered a kind of rhythm, which represents a repetition to a certain idea in certain way combining between change and unity . The first degrees of rhythm is repetition, which is the entrance of the artist to achieve the rhythm in design through the repetition of similar items and repeat spaces resulting from them and other forms of repetition. The repetition may include the element of diversity so that the pattern of repetition is not automatic and boring, and the work of art loses its appeal and dynamics. Diversity does not require a great deal of different units. The mere change in the space of the units' shape, dimensions, value, surface or colour achieves diversity within the work of art As for the repeat function is to confirm on the form or element, which also connects the vision visual with forms to occur some sort of unity in the construction of the artwork. The recurrence of the item or unit in the design to achieve a formal harmony which considers the important technical basics to achieve the aesthetic value of design .

The process of repetition is one of the systems interdependence between units, these systems must satisfy its function in the rhythms easier on the eye tracking and accepted.

The repetition has multi manifestation start from simple to more complex, and from part to all, the relationship between all the individual and the model is substituted which the all consist of parts and the parts are arranged in the colleges according to the multiple iterations, and in their patterns.

The mural paintings, which adorned the internal walls of the Faras Cathedral characterized with extraordinary collection of colourful ornaments which have high artistic value. which has emerged some systems of repetition through various methods either in spread, distribution , direction or style, which will be clarified in the following:

#### **5.1. Status of colour Repetition in Faras Cathedral**

Intended to trend repetitive element growth by analyzing the relationship part of the whole, there are multi positions and directions of repetition in accordance with the method of implementation on the surface of the artwork product, these are shown in Table (1):





Status of Repetition	Violet Style	White Style	Yellow-red Style	Multicoloured Style	Late Multicoloured Style
Horizontal					
Vertical					
Diagonal					
Quarter Direction					

Table (1) Status of colour Repetition in Faras Cathedral

### 5.2. Styles of colour Repetition in Faras Cathedral

The Styles of Repetition are Varied in the ornaments of different artistic styles in Faras Cathedral. But it was linked with the fabric of artwork in terms of rhythm, unity and diversity. This is illustrated in Table (2):

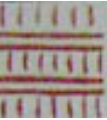
**- Identical Repetition:**

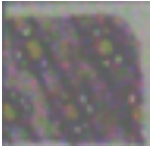
The Identical elements are repeated in all characteristics of shape, colour, size, texture and direction, making it fully again and this type will be more unified in style. The simplicity and easy application of this type of redundancy make it use into all of the styles as shown in the table.

**- Alternative Repetition (alternating):**

Any characteristic of the element or unit is alternated in it, the ornamental units or elements are alternated with each vertically or horizontally or diagonally or in any repetitive style, this type of redundancy allows the artist to change the colours or shapes, for breaking the monotonous of repetitive elements which have one shape and one systems . In the sense that the format may be in one size, but alternating the colour or texture or the location where it will be repeated and sometimes alternated the position, two different ornamental units or more can be used and vary in sizes or colours vary in succession one after the other.

It appears in the table alternative of elements by using more than one item in the regular alternative in terms of shape, position, and colour, sometimes irregular alternative is used by using two or more elements different in their arrangement and colour, as is shown in multi-coloured style and the alternative in direction did not use widely, it was used only in late multi-coloured style . The alternative in position is spread in most styles as shown in the table and the distribution of unit was triangle in the most styles . The alternative in colour has been used frequently in the elements or units unused in flooring.

**- Progressive Repetition:**

It is a sequential order, or consecutively of element ,that change in one quality or more , that means the element increase or decrease one of its characterize regularly in one direction or centrally, the form that may grow in size from small to large or gradually in size from large to small, and gradually in colour from light colour to dark, or range value of surface texture from fine to coarse, or gradually in the direction from vertical to horizontal and inverse, and advantages of this kind that contain the change Alternative repetition, but more movement, and given the impression of depth .

The Table shows the gradient in shape in the (Red and yellow styles) in the size of circles in the top bar is smaller than the circles in the bottom bar, the artist used the gradient also in the shape of arched tapes from large (at the top of garment) to small in the (Late multicoloured Style), the growth in the area of cross arms is used as shown in the (Multi-coloured style).













Styles of Repetition		Violet Style	White Style	Yellow-red Style	Multicoloured Style	Late Multi-coloured Style
Alternative	Identical					
	Element					
	position					
	colour					

Table (2) Styles of colour Repetition in Faras Cathedral

## 6. Conclusion

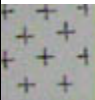
- The study proved that the artistic heritage of the Nubian (especially murals painting in Faras Cathedral) and the content of the aesthetic values has been its distinctive features, which can be a source to confirm the authenticity of this heritage.
- Mural paintings in Faras Cathedral, had repetition of color in different artistic styles through various methods either in proportion, spread, distribution or direction.

## References:

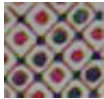
- 1- A. Abdel-Moneim,: Nubia, Cultural Library, Volume 58, Dar Alkalam, Cairo, 1962.
- 2- A. Faten,: Study of the Effect of Repeated Changes on Design Techniques and Aesthetics of Upholstery Fabrics Produced on Dobby Looms, Thesis Master's Degree, Faculty of Applied Arts, Cairo, 2004.
- 3- B. Kroma,: Logic and Design, great Britain at the pitman press bath, London, 1980.
- 4- E. Zain,: The Art History of Nubian and Sudanese Jewelry, Egyptian Public Organization for Book ,Cairo, 1978.
- 5- F. Ray, Z. Edwin,: Art today, Holt Rinehart and Winston, New York, 1996.
- 6- G. Mohammed,: Painting in Nubia, Supreme Council of Antiquities, Cultural of Ministry, Cairo, 1995.
- 7- M. Czamecka,: General Results of Using Decorative Ornaments and Motifs on Faras Murals as a Criterion for Their Dating, Nubia Christiana, Tom I, Warszawa, 1982.
- 8- K. Michalowski,: Faras, Wall – Paintings in the Collection of the National Museum in Warsaw, 1974.
- 9- S. Ahmed, A. Gouda,: Readings in Appreciation and History of Art, Published Helwan University, Cairo, 1990.
- 10- Z. Monieum,: Art and Design, Cairo, 1996.
- 11- [www.thenubian.net/nubold.php](http://www.thenubian.net/nubold.php).

# **Impressionist style in the design for printing women clothes fabric**

**Amany Hamdy Fahim Sanad**

Lecturer, Textile Printing, Dyeing and Finishing Department. Faculty of Applied Arts – Helwan University.Egypt

## **1.Introduction:**

Modern art includes several trends and diverse artistic schools that have rich aesthetic values. These values could be an important source of innovation and creativity specifically in textile printing domain. Effective school has been- the research paper's topic – the first introductory movement for modern art specifically the beginning of the 19<sup>th</sup> C. The School has formed the real start of modern art according to many graphic art critics. As a result, the artistic vision to nature has been freed after being subjected to the academic approach. The impressionists have based specific milestones for their artistic trend that focused on the light analysis to its original colours(rainbow). Also it focused on the emergence of brush's paintings and its effect on the portrait which known as contact and concerning the way of expressing the light and its reflection on the nature. They were affected by the lights of sea, shiningrainbow 'colours, and other motifs like flowers, trees, still nature, natural scene and other motifs that could be suitable for textile printing designs. Thus, the arts of this school including aesthetic and graphic values might be an important source of innovation and creativity in arts domain generally and in textile printing field specifically. Furthermore, it allows the designer a chance of inspiration by new-fashioned designs taken from the followed approach of the School.It is extremely important to renew and innovate women's clothes to update it according to the fashion; as a result, the idea of development came out as the Impressionism concept and its new colours.

## **2.The essence of Impressionism:**

The Impressionism is an important turning point in the western art history. It considers things and the life in general are in a state of constant moving and changing. The Impressionism approach in general, its methods, and its artistic tricks express and assert this reality. Theories and scientific facts of Newton and other scholars in analyzing the light have paved the way for the Impressionistic artists to think about new styles of colour-expression and aesthetic dealing generally. The impressionists have understood the importance of analyzing the colours on the portrait through painting adjoining, quick, and brief colour-spots to reflect the direct impressions and interactions of the artist towards the work of art' motif live and directly. Additionally, they have realized the importance of colour as a main element to build the shape or the element inside the work of art. Therefore, the process of controlling the choices of the colours to reflect the shapes and its link with the light that falls upon it is the main concept that it cares about[1].  
Cézanne's definition:

Impressionism? Is the visual combination of colours. It is a separation of colours on the painting and then recombining the colours on the eye. The painting does not and should not represent anything but colours. In fact, the visual blending and fragmenting the colours on the portrait mean to produce the desired colour by putting the colours side by side in order to give the blended colour effectiveness. The photographers before the Impressionists knew how to use the desired colour through combining the colours together[2].

Impressionist art is a style in which the artist captures the image of an object as someone would see it if they just caught a glimpse of it. They paint the pictures with a lot of color and most of their pictures are outdoor scenes. Their pictures are very bright and vibrant. The artists like to capture their images without detail but with bold colors. Some of the greatest impressionist artists were Edouard Manet, Camille Pissaro, Edgar Degas, Alfred Sisley, Claude Monet, Berthe Morisot and Pierre Auguste Renoir. The Impressionists incorporated new scientific research into the physics of colour to achieve a more exact representation of colour and tone.

The Impressionists loosened their brushwork and lightened their palettes to include pure, intense colors. They abandoned traditional linear perspective and avoided the clarity of form that had previously served to distinguish the more important elements of a picture from the lesser ones. For this reason, many critics faulted Impressionist paintings for their unfinished appearance and seemingly amateurish quality.

### **3. Analysis of the colours according to Impressionists:**

Each Impressionistic portraits is a record of a moment in the constant moving of the universe.

Presenting the light, the air, and the atmosphere, analyzing the evened coloured surface to colour spots and lines, separating the positioned colour to values, scared shivered spots, the rapid uncontrolled and surprising blows of the brush and every spontaneous technic with the rough quick drawing and the ephemeral realization. The Impressionism believed “that the light and colour” are the real motif of the artist’s vision.

They took the benefit from what the scholars represented in physics on analyzing the light and the colours. “vision”, the slogan of this school and trend is to record the visual impressions accurately, but they realized how it is difficult practically. Therefore, the artist is forced to intensity his motif and to free it’s shape to be coincidewith this impression.

Also they used the colour-patches. Hence, the old relation between the art and the nature has been weakened and it has become a relation between the artist and his vision of the nature. What they are in is division of the light that designates the colours which the artist feels [3].

The important distinctive characteristics of the colour for the impressionists:

- 1- The impressionists insisted on refusing the dark shadows and painting it.

- 2- The portrait of their colours are always pure and shining so they refused to blend the colour on mixing plate (palette) as a result, they got the bright shining colour degrees.
- 3- Most of their works were searching for the light away from the places of drawing. Thus, most of their works were in the fresh air in order to study the reflections of the light like the works of Monet, Pissarro, Sisley, and others.

#### **4.The colour and designing the textiles for women:**

The designs of women's clothes are designed considering the target of using it. Also it depends on the sort of activity that a woman practises. Each activity has its own different clothes and each one has different design according to the usage definitely.

Additionally, the designs of women's clothes differ in the design, the shape or the material regarding the variety of events categorized as morning clothing, noon clothing, house clothing, soiree clothing, and others[4].

It is not possible to imagine the fashion and mode without the colours because colour is an important element to evaluate and the most attractive.

We can express ourselves and the essence of feelings through the colours which is a great domain. Best choice and the glamour colours of the design and shape on the mode lead to a highly beautiful, harmonious and combined outfit at the end. Therefore, the colour helps to make the design successful and to achieve its target.

The successful designer who is able to deal with the colours and its denotation to increase the value of the design and to give it energy, vitality, and elegance to be coincided with the style of making the design. In fact, every used colour has a significance regarding its space in the outfit, or its relation with other colours in consistence and harmony.

Moreover, the element of colour represents an important feature of the character in fashion. The fashion designers focus on the composition of new colours each season. They use combinations of colours to be suitable together and to make the design successful, or they use only two colours to make the design.

In fact, the colour is what the designer searches for each season, what is the colour of the season?. Before choosing the cuts, the colour comes first[5].

#### **4.1.The Psychology of colour in dress:**

Costume designers, who use colour in the interpretation of the characters they dress, study the Psychology of it in dress minutely. "As the colour of the costume makes its presence felt more rapidly than its actual form it is necessary for the designer first of all to feel and reproduce the fundamental nature of a character through its colour presence.

People's ideal colours are based on personal points of reference on an intuitive understanding of the rules of colour harmony and contrast as applied to their hair, eye or skin colour, and on their ideas about their status, role, age or disposition.

In fact, anyone can wear any colour so long as its saturation and degree of lightness or darkness is aptly chosen. And apparel colours are modified by their relationship

to other colours in the ensemble, and by the colouration and dimensions of the wearer.

The Impressionists were concerned with studying the values of the colour.

Also they employ it in the portrait to represent the shapes in the nature through their realization and their controlling over the accurate differences between the colours. Additionally, they cared about the way of dividing the neutrals (the neutral colours): (white, black, and grey) in counted portions to achieve balance in the relations of the shapes inside the portrait. Thus, these shapes coexist together in a content of one colour-system **black** is the negation of colour. It is maximum darkness. perceptually , black implies weight and solidity ; darkness implies space, which is infinite. Persons who keep to formalities and etiquettes prefer black colour. **White** is maximum lightness .Insatiable and criticizing persons prefer white colour. **Grey** spans the extremes between white and black. A neutral grey is obtained when all spectral wavelengths are absorbed more or less to the same degree. [6].

Each colour is dragged in it's suitable content; for instance, the positive colours (red – orange – yellow). These colours are used appropriately and carefully.

**The red:** is the first colour in the rainbow. It is located close to the orange. Also it is caught by the eye when the approximate wavelength of light on retina ranges from 620-740 nm [7]. The red is the colour of energy and is connected with ambition and vitality. Additionally, it helps to remove the negative feelings, although it might be connected with anger if it is used excessively [8]. The bond between red and life has made it a significant colour in every culture on earth. The ritual representations of blood with the colour red pervade all tribal societies. Red is also the colour of aristocracy, of royal livery. Red is the way says "here I am!" makes you stand out in a crowd – whether as a party dress.

Sensitive and delicate persons prefer blue colour, while persistent, independent and strong persons prefer dark blue.

**The orange:** is the second colour in the rainbow and it's wavelength ranges from 600-650 nm. It is the colour of joy and feelings and it removes the negative feelings. In fact, it motivates the mind and renews the enthusiasm for life It behaves like yellow- cheerful, expensive, rich and extroverted. It is linked to comfort and security. If orange is akin more to yellow than to red in temperament, it is more akin to brown than either. The warm neutrals that occur between orange and brown are in constant demand for fashion and decorating. Its historical function in clothing is humble. "Orange- tawny" was the colour traditionally assigned to clerks and those of inferior position, and to jews Active, sociable and creative persons prefer orange colour.

**The yellow:** is the third colour in the rainbow and it's approximate wavelength ranges from 575-585 nm [9]. It is the colour of life, joy, and the sunrise, but the dark yellow as an example reflects negative feelings like fear [9]. So each colour could



reflect a negative feeling and a positive feeling. This paper is concerned with new concept of adjoining the colour in women's clothes in a simple style in order to get the colour out of the shape ' limit and the frame.

Yellow in its pure form radiates warmth, inspiration and a sunny disposition. It is the happiest of colours[10]. Yellow dress is today more prevalent in the orient than in the west. Mentally active and creative persons prefer yellow colour, while self-indulgent persons prefer golden colour.

And the cold colour the same Each colour is dragged in it's suitable content

**The Blue:** has historic and symbolic associations with royalty. It is a peacemaker of colours: cool, soothing, orderly. Blue is a favorite clothing colour for children and young adults, whose affinity for blue denim is apparently boundless. Blue is a fact of working life, partly because the hardy indigo plant grows the world over. Sensitive and delicate persons prefer blue colour, while persistent, independent and strong persons prefer dark blue.

**The Green :**Green associated with emotional balance (bred, as it is, from happy yellow and tranquil blue) also signifies the most vertiginous emotion, jealousy; that the colour of freshness. The wearing of green has had its share of meanings. Green is the colour of the planet Venus, and therefore of love. green was traditionally worn at weddings in Europe [11]. Sentimental persons who lack the feeling of safety and stability prefer green colour.

**The Violet:**

Purple and violet between them encompass vast differentiations in hue. Violet is a pure spectral hue. Purple is a dual, or mixed colour.

The appearance of violet in the human aura is interpreted as a spirituality if light and depression if deep [8]. Purples in fashion have had a chequered career. The brighter magenta overtook mauve in popularity during the latter half of the nineteenth century.

Ideal and romantic persons prefer violet colour.

The Impressionists use the colour Therefore, any limitation of shape, frame, structure, and shadow disappear and nothing remain but the colour-spots and the magic of colour. This method of using the colours has helped those artists to be able to rapidly record their visual realization, impressions, and interactions toward the motif of the work of art live and directly with no fabrication. They expressed these impressions and delivered to the audience spontaneously. It is not fake and it is far away from restrictions of embellishment and accuracy in the details with reflecting the state of pace and the instantaneous action of the shapes. The artist has to paint as quick and flowing as the action in the nature in order to catch these vanished moments . "if the motif of the painter was in flux ,then the painter too had to be in

flux moving rapidly to transcribe accurately the motif's fleeting character" This has led to the increase of vitality and colour-varieties.

the Impressionistic artist always gives his portrait the spontaneous, unplanned, and rapid extract. It reflects the impression of vitality and simplicity in his works through these brief, divided, and rapid painting.

The artist paints the brief and abstract shapes, but the mind of the audience goes through it's reality skipping these shortcuts. This turning is the real contribution of the viewer in the transcription.

"Just as apparently quick –painting my not always have been executed quickly,so rapidly made painting don't always " look " rapidly painted .the aesthetic of rapid painting can be a "look" or a series of usual codes as much as the result of true rapid execution."

"Spontanty is probably apparent as much as it's actual , rapidity of execution is More often an allusion than of realty"

"The result of the combined activities of the eyes and hand is a kind of "automatic painting " in which transcription was so easy that it appeared "natural"[6].

Thus, the research focused on designing women's clothing according to the view of Impressionism due to the necessity of renewing and creativity. Here in; some design ideas are proposed in addition to introducing a vision of the researcher's design to employ it.

## 5. innovative designs

### 5.1. First Design:

This design contains some of the positive colours, Red, Orange, mixed with black and white, putting the colours side by side in order to give the blended colour, the design appears on their face brush's blows, to attract the attention.



Fig. 1- the first design is inspired from the impressionistic style and using it in women's clothing

## 5.2. Second Design:

This design contains a congruent mixture of color, mixed with black and white, putting the colors in color patches. The colors have some shading to attract attention.



Fig. 2 - the second design is inspired from the impressionistic style and using it in women's clothing

### 5.3. third Design

This design contain's ,Red ,Blue,white, yellow ,mixed with black ,putting the colours side by side in order to give scoleciform trend .to give a new Artistical design.



Fig. 3 - the third design is inspired from the impressionistic style and using it in women's clothing

#### 5.4. fourth Design:

This design have intersecting lines Randomness ,mixed with colours, blue ,yellow, a few of red colour and white look's like's brush's blows .to give a new Artistical design for womens wear



Fig. 4 - the fourth design is inspired from the impressionistic style and using it in women's clothing

## 6. Conclusion:

The outcomes of the research paper are:

1. To get only the benefit of freeing the colour from the limitation of frame and colour's magic in order to design women's clothes matching the fashion.
2. To use the Impressionism School 's vision and to develop women's clothes with new vision through it.
3. The element of colour is enough to design modern and new-fashioned women's clothes.

## References:

- [1] A. Goda: "Readings in New Art" (QeraatfeElfanElhadeth), 2008
- [2] Richard R. prttel: "impression painting quickly in france", new haven London ,2000.
- [3] A. Mahmoud: "What is beyond the Art" (Maawraa El-Fan). The General Egyptian Books Organization, 1993.
- [4] N. Bawzeer: "The Fashion and Art of choosing the Suitable Outfit (Al mode w fan ekhtair El malbs El munasb) Dar Al Fikr El Arabi in cairo, 1998.
- [5] M .Zaki: "Graphic and Art", Dar-El marf, 1996.
- [6] B.denvir : "Impressionism the painters and the paintings ", London, 1991
- [7] D.russel: "The red book", north light books. Cincinnati, Ohio 1990.
- [8] H.chijiwa: "Colour harmony" rock port published, 1994.
- [9] D.russel: "The Yello book", north light books. Cincinnati, Ohio 1990.
- [10] S.chiazari: "The complete book of colour ", element books limited, 1998.
- [11] L.Amiel: "Colour", New York, 1980.





# Stability disruption of a nail polish shade.

<sup>1</sup>Claire Pierron, <sup>1</sup>Delphine Roger, <sup>1</sup>Gille Planeix, <sup>1</sup>Nathalie Baudouin, <sup>1</sup>Helene de Clermont-Gallerande

<sup>1</sup>Chanel R&T, Pantin, France {claire.pierron; delphine.roger; gille.planeix; nathalie.baudouin; helene.declermontgallerande}@chanel-corp.com

## 1. Introduction

A classical nail polish is composed of resins, polymers and plasticizers which are solvated and dispersed in solvents [1]. The cosmetic properties are defined by the choice and the ratio of each of these ingredients.

In order to obtain a colored product, pigments and/or pearls can be added. Pigments are grinded and disagglomerated in a colorless base in order to be easily used by formulators. Therefore, their particle size is optimized for a nice and homogeneous color in bottle and during the application on nails. But these particles are submitted to gravity and can settle.

A blue shade of nail polish, mainly composed and black iron oxide and Ultramarine pigments, shows a stability disruption, depending on the manufactured batch. Black iron oxide completely settles. Therefore, the product color is not conforming anymore.

The objective of this study is to understand why this phenomenon occurs and what can explain it.

## 2. Material and methods

To prevent settling, a suspensive system is introduced in some nail polishes bases. It leads to a thixotropic behavior. It allows maintaining solid particles in suspension during storage, and to fluidify the nail polish during application to ensure a good quality of use. After application (which can be compared to high shear), the nail polish needs to recover its initial viscosity to guarantee product durability.

The suspensive system, classically a quaternized clay, needs a polar agent to allow its pellets to be well separated and efficient. The polar agent used can be an acid. It can modify the pH of the base, and therefore its stability and its capacity to suspend solid particles [1] [2].

The Ultramarine pigment is sensitive to pH (more stable in basic conditions).

By developing a relevant pH measurement method for nail polishes (which are not in water-phase), we characterize the batches of Ultramarine base.

Batches of the aforementioned color, containing Ultramarine base with variable pH values, are made and stored at different temperatures, in order to accelerate the ageing. These stabilities are faced to the pH values, in order to look if there is a bond between them.

## 3. Results

When Ultramarine base pH is superior to 7, the stability is KO. Black iron oxide settles.

As the pH is basic, suspensive system is not activated, clay pellets are not well separated anymore and heaviest solid particles fall to the bottle bottom. It leads to unacceptable aspect of the finished product.

We determine a range of pH values for Ultramarine base, for which stability of the final nail polish is conforming.

#### **4. Conclusion**

Physico-chemical characteristics of raw materials can bring some issues, as pH, even in a non-water-phase system. By developing a pH measurement method specifically applicable for solvent nail polishes, we can select the best batches of Ultramarine base, for formulating new shades with a good stability.

#### **Bibliography**

[1] D. Laba, Rheological properties of cosmetics and toiletries, pp. 153-223, 1993.

[2] A.A Patil, R.W. Sandewicz, NailLacquer Technology , Monograph Number 6, Society of Cosmetic Chemists

## Do the Polish dislike colour?

### Bożena Groborz

Jan Matejko Academy of Fine Arts in Krakow, Faculty of Industrial Design, [bgroborz@asp.krakow.pl](mailto:bgroborz@asp.krakow.pl)

This presentation shows how historical and political events affected fashion preferences of Poles in the 20th Century. Why is that some of the color and graphical trends were widely accepted and adopted and some where completely rejected?

For contemporary Polish designers the 20th Century is a source of inspiration for the fashion. However, upon that inspiration they mainly seek for knowledge on, so called, world trends and highly acclaimed and widely honoured designers' achievements.

Not so many of them date back to actual offer of shops or factories within selected time frame. These are the facts that give us true image of consumers' preferences and spirits. These facts can also help to understand why Poles were not always stylish and trendy.

The 20th Century in Poland abounds in examples of both the total acceptance and complete rejection together with creation of ones own ideas.

First events were connected with times of dynamic development and cooperation with foreign markets (the Twenties and the Thirties). Another factors were of historical and political nature and include times of being under partitions, communism and closure of the borders, state of siege and the crisis of the Eighties.



Fig. 1 – printed textiles, 1920s, polish factories

One would still wonder whether following fashion trends of the Thirties caused the collapse of Polish cotton industry. During the crisis Polish producers were not able to keep up with new technologies in the area of fabric printing used by foreign manufacturers, hence were not able to meet the demand of market. As a result, fabrics produced in the Thirties were astonishing when it comes to design, however they remained unsold. Despite the crisis and high prices Poles decided to go with imported fabrics.

Complicated and rich in various events history of Poland in the 20th Century caused, that home born printed fabric industry has produced number of extraordinary designs.

Amongst them one can find art of printing masterpieces, naive designs ordered by the Government (that was convinced that it can manage the fashion based on political guidelines), feeble printed designs painfully showing weaknesses of postwar centralized economy.

All of the above examples in the area of printed fabric industry can be found buried deep down in old closets of the museum in Lodz and Warsaw and only few managed to actually get to them.

In the following presentation I recount the example of two selected periods preceding the recovery of independence by Poland – the years 1900-1918 and the decade following the end of World War II.

## **2. Years 1900-1918 - Accepting World Trends**

The beginning of the 20th century brought about the widely longed-for changes in lifestyle, customs and fashion. The first decade of the new century was the time of the birth of modernism, as well as the greatest flourish of the Belle époque, which had been around since 1891. Love for rich decorations and opulent life filled with abundant details - patterned wallpaper, paintings in large gilded frames – had an evident impact on women's fashion, which – in its emphasis on femininity and glamour – had more in common with the 18<sup>th</sup> century than with the onset of the new millennium. With the end of the Civil War in the USA in 1865, and the Franco-Prussian war in Europe in 1871, a time free from armed conflict began, which swiftly resulted in immense technological progress, speedy development of industry and trade, and emergence of great fortunes. This dictated the acceptance of a new lifestyle, radically rejecting the world of Victorian values (Queen Victoria died in 1901). This lifestyle was best expressed by the newly opened Ritz hotel – the symbol of the ceaseless pursuit of amusement and the ever more popular “joyful consumption”. The turn of the 20<sup>th</sup> century brought about new discoveries in sciences (the theory of relativity), psychology (Freud's and Jung's studies in psychoanalysis and sexual repression), as well as new trends in art (Art Nouveau, Symbolism, Fauvism, Expressionism, beginnings of Cubism). Similarly, a new image of a woman appeared - more and more frequently, it was an image of an

independent, professionally working woman, self-reliant and claiming her rights. (In 1903, suffragettes started their public activity in the USA). This change necessitated a redefinition of women's clothing, which gradually ceased to constrict women and allowed them freedom of movement with the simultaneous possibility to express one's self. In these strivings, women were assisted by the movement, which originated as early as in the second half of the 19<sup>th</sup> century, and which united doctors, artists, pedagogues and many others, unequivocally demanding a reform of women's clothing. Their most essential proposition was departure from the use of the corset, which deformed the natural female shapes, causing many serious ailments. This was compounded by the fact that the lifestyle preferred at the time – health and sport focused – required more comfortable clothes. Interestingly, renouncing corsets turned out to be hardest for women themselves, perhaps because, having been worn for ages, they became ingrained in the mentality of women, not used to the acceptance of the female body as it really was.

The turn of the 20<sup>th</sup> century was predominantly the time of clothes and fabrics designed in accordance with the premises of Art Nouveau in all its varieties: both the “whiplash” one, full of decorative flowing lines, and the one drawing from the Viennese style, characterised by “purer” geometrical forms, corresponding with the rational modernist ideas. The influence of post-impressionist painting and Cezanne are visible in the colours and patterns of fabrics (flatness of the pattern), while the forms are inspired with the Neo-Gothic and Neo-Renaissance. Flowing lines and muted, pastel colours characterised Art Nouveau clothes and patterns. Black was still popular, though. In each country, a separate Art Nouveau pattern styles evolved.

### **Orientalism**

Shortly before World War I, Paul Poiret, a French designer, exerted an immense influence on pattern and garment design. Called the “Sultan” or the “Pasha of Paris”, he developed the “oriental line” of Art Nouveau in his designs, which was closely linked to Japonism, popular at the time. This was complemented by the fact that the almost immemorial longing for the fairy-tale exotic, harboured by the Europeans, was successfully stirred by Diaghilev's Ballets Russes, which made a sensation in Paris at the time. This fashion resulted in the introduction of vivid and saturated colours into the elegant parlours (where muted pastels had reigned almost exclusively so far), contrastingly matched, as if drawn from Fauvist paintings. The wave of admiration for the new colour palette influenced even the colour of stockings worn at the time (which were, naturally, rarely in full view). The black stockings, typical for the Victorian period gave way to, predominantly, red and golden ones.

### **POLAND**

Art Nouveau, broadly understood, reached Poland as well. If architecture and decorative arts were largely under the influence of its Viennese variety (mainly due to the Austrian partition) and the attempts at creating a “national” style inspired mainly by the production of the inhabitants of Podhale, women's fashion was shaped by French Art Nouveau.

In Poland – just as it was in Paris – a slender and attenuated “S” line was the desirable one, the subtlety of which combined with the luminous colour palette. Many women from the so-called high society accepted the comfortable oriental fashion promoted by Poiret. To the motifs used in decoration - lilies, insects, peacocks, swans, slender female figures and girl’s heads (which were popular everywhere) - Polish poppies, irises, pansies as well as thistles and carlinas were added. There was general preference for the so-called “floral Art Nouveau” in patterns applied on fabrics. From around 1910, the manner in which the forms of the patterns were interpreted resembles the designs of the Polish artist and designer Karol Tichy, a harbinger of the Art Dèco style.

Owing to the ever active efforts to retain the Polish identity despite the partitions: “Attires in the national style are promoted in Poland, in the design of which elements of folk costume were used, especially the highlander and the traditional old Polish one: jerkins, belts, żupan long garments, konfederatka hats and kontusz sashes. A collection based on highlander folk costume was presented in Bogusław Herse Fashion House in 1902”.

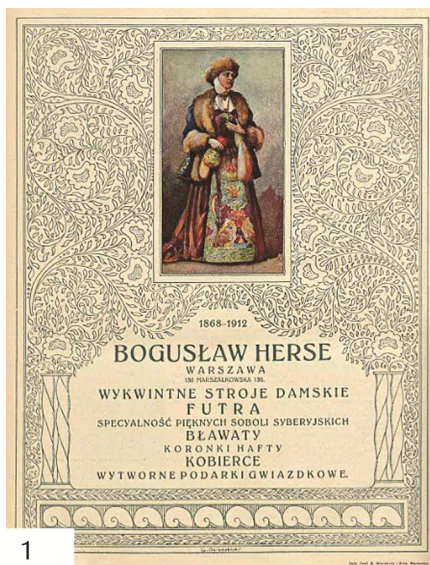

1



3



3

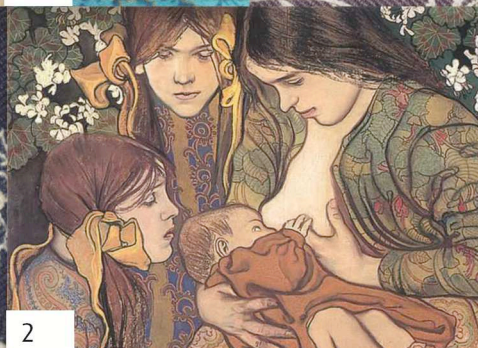

2

Fig. 2 – 1. Boguslaw Herse, advertisement, collection 1912 inspired by historical styles | [http://4.bp.blogspot.com/\\_6PononYbX50/S0W\\_rPHsz3I/AAAAAAAAAfo/Jd\\_j0CxoTgM/s1600-h/herse1912.jpg](http://4.bp.blogspot.com/_6PononYbX50/S0W_rPHsz3I/AAAAAAAAAfo/Jd_j0CxoTgM/s1600-h/herse1912.jpg);  
2. Stanislaw Wyspiański, Maternity, detail; 3. printed textiles, cotton, Poland territory, 1900-1914 | <http://www.numizmatyczny.pl/photo/Macierzynstwo.jpg>

As in the whole of Europe, a relatively wide colour palette is favoured in the Polish regions. On the one hand, it was a whole range of whitish colours, worn in summer or in the evening: shades of white, pearl, pale purples and pinks, pale grey, cream, golden brown, tobacco brown, turquoise and green – all of them pale and greyish. At the same time, black and well-saturated colours were worn. Black, just as popular as pastels, played various roles. A black silk dress was a “sign of a high social status and elegance”. Black was also frequently worn by representatives of the artistic boheme, such as Dagny Przybyszewska, the muse of Kraków artists.

Initially, Art Nouveau fashion found no acceptance in Poland. The floral and animal motifs it applied were criticised as stiff and dead. However, Polish women soon appreciated its assets and were unwilling to abandon Art Nouveau style when new trends appeared in the second decade of the 20<sup>th</sup> century. Together with the fashion for the antique and oriental in the years 1910 -1920, the popularity of pale colours and white increased further, as they were ideal for attires modelled on Greek chitons. At the same time, the oriental fashion enriched the colour palette with sets of contrasted, very saturated colours: “green, khaki, azures, reds as well as bluish and reddish violets”. Fabrics were decorated with checked, striped and dotted patterns, or floral motifs of large fanciful forms, treated graphically or composed of blurred spots of colour. Ikat and batik techniques of decoration were very popular. Both original examples of such fabrics, but also their copies in the form of printed patterns were fashionable. Batik articles produced by Warsztaty Krakowskie largely contributed to this popularity. Their colours and exotic character fitted Poiret’s decorative fashion, reigning since World War I. Batiks from Antoni Buszko’s workshops are also a great example of an individual adjustment of world trends in accordance with the political and social atmosphere in Poland at the time. Patterns on shawls and kerchiefs, which even gained a specific name of Polish-Javan style, were not copies of the imported models, but original folk motifs from villages near Kraków, transformed in the spirit of the fashionable technology.

Another feature very characteristic of Polish industrial production was the penchant – present irrespective of any fashion – for red, navy blue, black and white, usually combined in two-coloured patterns. Fabrics printed in this manner enjoyed the greatest popularity among the customers of textile stores.



Fig. 3 – printed textiles, Polish territory, 1900-1914

## 2. Years 1947-59

Another highly interesting period demonstrating how political and economic factors have influenced Polish fashion is the period after World War II.

The first years following World War II were the time of economizing and shortages of goods, which definitely was not conducive for the development of fashion in Europe. In contrast, the American market, on which the war had not taken so much of a toll and which had placed emphasis on design since the crisis of the 1930s, developed quite well. However, Paris Haute Couture designers did not remain idle and, starting from the end of the war, strove to soften the angular “war-like” feminine figure. After the “lean years” of the war, a desire for luxury and elegance increased, so as to forget about the horrors of the past years and express the joy of regained independence.

New Look, the symbol of the design of the 1950s came in two waves, so to speak. The first of them, inspired by organic modernism and sculpture, embraced



architecture and any spatial object, including female figure and fashion. The second one concerned any graphic pattern and, reflecting all the current achievements of abstract painting, transformed fabrics, wallpaper and pottery. 1947 was not only the year of a great breakthrough in fashion, it was also a year when Jackson Pollock made his first large scale action painting. In the same year (1947) Picasso took up pottery and his works significantly influenced pottery design around the globe, especially in Italy and England. On fabrics, on the other hand, patterns appeared which corresponded to the ceramic design by the artist.

Innovational fabric designers, such as the married couple Lida and Zika Ascher, grew to become real international potentates in the field. The Aschers were among the first to understand the vast potential of abstract painting. As early as 1947, Gerald Wilde designed powerful abstract patterns for Ascher, reflecting the energy of action painting, which had only begun to make its way to the mainstream of art at the time. Though significantly decreased in size in comparison with Jackson Pollock's original canvases, his works applied on textiles do not lose their energy contained in the rhythm of abstract expressionism. In the first post-war years such attitude was not popular among producers. Only Horrockses, who released fabrics "scribbled and smudged" in abstract patterns onto the market as early as in the late 1940s, was of similar mind. Mass production of textiles covered with abstract patterns only started in 1953.

A whole range of textiles inspired with Joan Miró's artwork – above all, his paintings and mobiles, but also the structure of the atom – came from the 1950s. Changes which took place in the colour scheme of fabrics and garments of the 1950s can be divided into several basic stages. The war years were the time of frugality ruling everything – including the colour palette. When the war ended and the economy started to thrive, the desire for colour exploded in every aspect of life. Upholstery, curtains, domestic objects – sported various colours in all possible shades. However, it would be wrong to think that the 1950s were times of "colour anarchy". Colour schemes were designed in accordance with strictly defined rules, with the assistance of psychologists specialising in the psychology of colour.

## **POLAND**

In the post-war era, Polish fashion reflected the harsh situation of Poles living behind the iron curtain. Dependent on the centrally planned economy, they were forced to accept the unification of dress similar to the one advocated by Soviet dissidents in the 1920s. All this contributed to the fact that Polish attires differed significantly from what was promoted in Western Europe. It was a unique resultant of thousands of kilometres of identical, boring fabrics produced by the nationalised, monopolistic textile industry and long series of garments produced in the the clothing industry factories. Both industries were controlled by the authorities with respect to the number or metres of fabric and items of clothing produced, which constituted the only criterion of their assessment (disregarding the issues of quality, aesthetics, or actual demand). State production of this period provided fabrics covered with the "immortal" patterns of dots, fine check, and flowery "meadows" –

the same patterns had been fashionable in the 1930s, as a certain opposition to the dynamics and experimentation of the fashion of the 1920s. There is something specific about these patterns which makes a woman dressed in them seem gentle, less aggressive and more submissive. The other group of the so-called “righteous” patterns were those inspired with folk culture, which had always been well-liked by totalitarian systems. Non-figurative, modern and experimenting art was in fact forbidden as harmful and dangerous. Identical attitude of the authorities towards modern art could be observed at the dawn of the totalitarian regimes in the Soviet Union and Germany before World War II.



Fig. 4 – 1. Jacon Pollock, 1947 | <http://www.goldbergmcduffie.com/projects/artnews/pollock.jpg>  
 2. Printed silk, ab. 1960; . Dress 1954; printed textile by Horrockses company, 1953 | JACKSON Lesley, *The New Look Design in Fifties*, New York 1991  
 3. Wojciech Fangor *Figures*, 1950 | [http://www.dziennik.pl/files/archive/00143/fangor\\_postaci\\_1\\_143487g.jpg](http://www.dziennik.pl/files/archive/00143/fangor_postaci_1_143487g.jpg)  
 4. Printed textiles, Polish Cotton Factories in Łódź, 1950s  
 5. *Town*, movie 1950 | [http://www.film Polski.pl/fp/index.php/162248\\_9](http://www.film Polski.pl/fp/index.php/162248_9)  
 6. Harold Cohen, *vineyard*, screenprint, 1959 | JACKSON Lesley, *The New Look Design in the Fifties*, Nowy Jork 1991

As a certain statement made famous by Oscar Wilde goes, the sense of being in line with fashion gives a man a confidence which religion could never give him – therefore, fashion was one of the most important “openings” through which some fresh air reached Poland from the “degenerate West”. These were second-hand clothes and UNRRA donations, as well as clothes sent in parcels by Polish diaspora in foreign countries, which introduced a breath of freshness and worldliness into the Polish fashion until about 1954.

The colours of textiles produced in Poland did not depend on fashion or Polish people’s likes and dislikes, but on what was currently stored in the production raw material or ready product warehouses. When Paris or USA focused on subtle, but pure “flower” colours, Polish production lines punched out poor quality fabrics in the tones of dirty brown, green, ochre or blue. Pale colours were rarely used.



Fig. 5 – 1. Printed textiles, Polish Cotton Factories in Łódź, 1950s

2. Printed textile, Polish Silk Factories in Leśna, 1950s

3. Aleksandra Michalak-Lewińska 1955-6, designed for IWP

Fortunately, there was, in this post-war reality, a woman who significantly contributed to the development of Polish design, including printed fabric. This was Wanda Telakowska, the author of the slogan “Beauty for every day and everybody”. It is worth noting that in its main meaning the slogan was consistent with the general world tendency to surround man with beauty in every day life. In the 1950s, this resulted in the development of Western design in all aspects of life. However, in the Western countries conclusions were drawn from the previous experience and artists were actively involved in designing utilitarian art. At the same time, the achievements of modern art were popularised by means of beautiful, well-designed objects. In Poland, design rejected all earlier experience, both national and international, starting its way from craft to design once again. Furthermore, the activity of artists-activists (motivated by communist ideas) contributed more to the separation of “pure” and “utilitarian” art. Despite these obstacles, Wanda Telakowska managed to approach artists, who were employed at designing models for industry. The designs were primarily made in artists’ cooperatives, such as the famous “Ład” and “Arkady” in Warsaw, or “Wanda” in Kraków.

In 1950, (Biuro Nadzoru Estetyki Produkcji – Production Aesthetics Supervision Office) directed by Telakowska was transformed into IWP (Instytut Wzornictwa Przemysłowego – Institute for Industrial Design), which significantly influenced Polish fashion and textiles throughout the 1950s. Designs made in cooperation with folk artists were very characteristic of IWP. As I have mentioned earlier, the trend was supported by the communist authorities, which were convinced that the inspiration for Polish patriotism and the proper citizen attitude could only be found in the simple minds of Polish villagers. Because of the application of the idea of “socialist in content, national in form” in their creation, the Polish “folk” designs of the period had practically no equivalent in Western fashion.

Owing to this fact, the legacy of Polish textile industry comprises, among others, very well-designed printed fabrics inspired with the paintings of Zalipie village women, cut-outs from Kurpie region or painted Easter eggs from Kunów i Krzczonów, as well as embroidery and laces from Silesia, Zakopane or Kurpie. Folk inspirations also influenced the colours. While the whole world of Western fashion was steeped in pastels or pure flowery tones, in Poland many fabrics in saturated or dark colour were produced.

It is worth noting that the decorative textiles developed much better at the time, owing to, among others, the activity of Józefa Wnukowa and her studio operating in Państwowa Wyższa Szkoła Sztuk Plastycznych (State School of Higher Education in Art in Gdańsk (established in 1945 r.)). Fabric patterns created under her guidance demonstrated a much greater sensitivity towards the trends and artistic styles developing in the world.

Luckily, apart from the “folk” ones, designs of other types were also created in IWP Textile Factory. They were definitely closer to the general world tendencies, although much more frequently these were figurative designs, rather than examples of the adaptation of the achievements of abstract expressionism. The designs were created with the new technology of automatic screen printing in mind, which allowed for a better transfer of half-tones onto fabric (in the USA technology allowing for good half-tone rendering had been developed as early as the 1930s, see

p. 113-122). Patterns appearing in the designs of the 1950s were made on an assigned topic (such as the ZOO, Botanical Garden, bird plumage, Mazowsze landscape, Warsaw). Egyptian, Indonesian or African themes were also explored for inspiration.



Fig. 6 – 1. Alicja Gutkowska-Łasicka-Wyszogrodzka, designed for IWP  
 3. Aleksandra Michalak-Lewińska, 1951, designed for IWP  
 4. Danuta Michno-Paprowicz, 1957, designed for IWP  
 5. Printed textiles, Polish Cotton Factories in Łódź, 1950s  
 6. Janina Lau, design, State School of Higher Education in Art in Gdańsk, end of 1940s

In the early 1950s, the colour palette became lighter (without any colour preference), but often colours were slightly “muddy”, without the luminousness characteristic of the world tendencies. Fabrics appeared with a large quantity of white unprinted background. Beiges were popular, as well as pale greys.

Examples of products from the former Ludwik Geyer factory, named Zakłady Przemysłu Bawełnianego im. Feliksa Dzierżyńskiego w Łodzi (Feliks Dzierżyński Cotton Industry Plant in Łódź) in the 1950s, demonstrated that modern art shyly penetrated into factories, bringing about, for example, designs reminding of Tachist painting. These were not frequent motifs, however. Also the remaining sources of inspiration, such as folklore and Far East demonstrated the tendency characteristic for the general world trends in decoration: synthetic treatment of figures and distinct contour (reminiscent of Nacht-Samborski’s and Joan Miró’s painting).

Around the mid 1950s, a lighter palette established itself, “purified”, and, together with patterns whose design was more and more frequently entrusted to fine art academy graduates, contributed to the emergence of new interesting designs. In the aforementioned Zakłady Przemysłu Bawełnianego im. Feliksa Dzierżyńskiego in Łódź, a “new design” appeared “drawing on the trends in French fashion of the time.

Floral patterns in the “Picasso” convention and motifs obtained with the use of flowing, blurred wide spots of colour became popular. In both cases the manner of presentation obscured the real shape of the flowers, making them closer to abstract forms”.

Apart from this, the usual was printed – fine stripes, miniature check and colourful “flowery meadows” and, naturally, the immensely popular polka dots, in any possible variety. The palette of the aforementioned patterns became light and clear at last, with evidently preferred shades of sea green and blue, or warm white matched with black and yellow.

#### **4. Conclusion**

Similar differences in the attitude to fashion may be observed throughout the 20<sup>th</sup> century. Most of them resulted from the turbulent fates of the Polish nation, repeatedly fighting for its independence. The attitude to colour in attires became an instrument for fighting on the both sides of the barricade. It was not always connected with fashion - frequently it was used as a way to express opposition or support. In the times of partitions, Polish nationality was accentuated by drawing on models from the heyday of the Polish state. Later, when the authorities tried to “uniform” the society, making it into a gray mass deprived of any individual characteristics and cut off from the rest of the world, the society opposed it by trying to keep up with the forbidden trends.

#### **Bibliografia**

- G. Forcolini, “Illuminazione LED”, HOEPLI, Ottobre 2008.  
F. Boucher, “Historia mody”, 2003.  
A. Dziekońska-Kozłowska, “Moda kobieca w XX wieku”, 1964  
P. Jaworski, L. Maćkowiak-Kotkowska, K. Stanilewicz, “Dawne zakłady Ludwika Geyera 1828-2002”, 2006  
K. Mulvey, M. Richards, “Kanony piękna. Zmieniający się wizerunek kobiety”, 1998  
M. Walch, A. Hope, “Living Colors, The definitive guide to color palettes through the ages”, 1995

## **8. COLOUR AND CULTURE**





# Colour as a continuous protagonist of the multidimensionality of plastic languages

<sup>1</sup>Ángela García Codoner

<sup>1</sup>Universitat Politècnica de València, angarcia@ega.upv.es

Probably, Pop Art was the first artistic movement to reach such an unprecedented international expansion.

Last year, 2015, Tate Modern (London) opened a large international exhibition that, under the title *"THE WORLD GOES POP"*, recollected samples of pop art from around the world while wisely omitting, for as far as it is possible, the American pop, already established and enthroned in the history of contemporary art.

Lucy Lippard was at the time, with her book *Pop Art* (N.Y. 1966), the critic who theorised the new language, setting America as its place of birth and development.

American pop dethroned abstract expressionism and led the return to a new figuration, which meant a warm and accommodating portrait of the consumer society, often trivial, characteristic of a part of the polyhedral *"American way of life"*.

The iconographies and bright colours are actively involved in this newborn language, which quickly spread in and outside America.

The crucial centre of pop was New York and, through a direct and colourful language provided by the media and advertising companies, the American *"Happy Life"* was portrayed.

The new language spread very quickly around the globe. The research carried out by the curators of the exhibition *"THE WORLD GOES POP"*, Jessica Morgan and Flavia Frigeri, has shown, in the great showcase that is the Tate Gallery in London, the development and acceptance achieved at the time by the new language among very far apart artists.

The exhibition shows the great dissemination of pop in different geographic coordinates and, most importantly, how the language was used in artistic creation, which has led to know the idiosyncrasies of the different origins of the artists and countries and how pop was used throughout the artistic world.

Outside America, pop worked differently; it was a very useful tool for political critic and vindication. The pop became a subversive tool, setting a new straightforward and unsophisticated language to denounce dictatorships and the oppression of minority groups.

"...New York was perceived as a centre from which pop art radiated, it omits the possibility for alternate pops to exist independently of the Anglo-American axis. However, pop art not only existed but thrived outside of the official pop hemisphere. Distinctly and critically removed from American cultural heritage, global pop artists had little interest in Andy Warhol's feats, or those of his companions: they pursued pop as a device to reflect on current events and voice their social and political convictions, of which America was often the target. History, politics and societal shifts were global pop's daily bread and while the visual language –garish colours and bold images- showed some affinities with mainstream pop..." [1].

This review of the 60's and 70's of the past century has recognized the worth of a number of lesser known works, perhaps further to the development poles where Pop was born and belongs.

As it borrows the essence of its language from advertising and mass media, pop obtains the way to express and communicate a straightforward and extremely explicit perception for the spectator. Texture, chiaroscuro, transparency, they all are removed so that the automatic power of image reaches the viewer in a schematised way in order to make the message more direct and absorbent.

In this situation colour is the main protagonist, the chromatic impacts are of great intensity depending on the message or the exaltation of the image itself that has the leading role as unique value.

This blunt language, deprived of any technical sophistication regarding the use of tradition, was used by the artists of the time as an instrument to exercise social, political or gender criticism. For the artists, this was a magnificent discursive tool to highlight the democratic deficits of some countries or, as in the case of feminism, unequal treatment.

“Women’s emancipation together with countercultural movements, for instance, were key among the societal shifts redefining not only the traditional familial structure but also society as a whole” [2].

Pop, throughout the world, overstepped its fake banality to exert as a communication tool and denounce the politics of authoritarian governments or the condition of minorities or social groups deprived of the necessary democratic mechanisms.

“The space and nuclear races, the two biggest by-products of the USA-USSR Cold War match, and the Vietnam War with its twenty-year string of atrocities, were the source of ongoing debate. Dictatorial regimes, from Francisco Franco’s in Spain to the succession of military dictatorships in Brazil and Argentina, curtailed freedom and replaced it with fear. And in the midst of all of this many followed with alarm or trepidation the rise of consumer culture. National events of course also played a role but those events that made headlines internationally were at the fore of global pop’s concerns” [3].

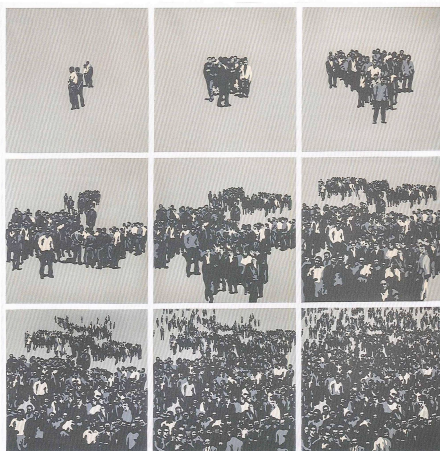

Fig. 1 - Equipo Crónica, Concentration or Quantity Becomes Quality, 1966. Acrylic paint on canvas, 160 x 160 cm, Spain. From Frigeri and Morgan 2015.



Fig. 2 - Bernard Rancillac, At Last, a Silhouette. Slimmed to the Waist, 1966. Vinyl paint on canvas, 195 x 130, France. From Frigeri and Morgan 2015.

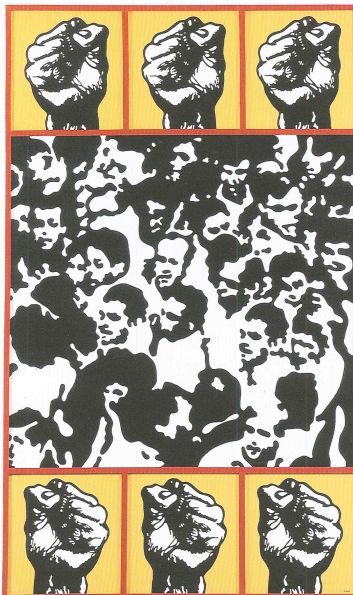

Fig. 3 - Claudio Tozzi, Multitude, 1968. Acrylic paint on agglomerate, 199 x 120, Brazil. From Frigeri and Morgan 2015.

The exhibition displayed the work of many artists from very different origins, France, Romania, Poland, Czechoslovakia, Finland, Norway, Spain, Iran, Greece ..., not leaving out South America or Japan.

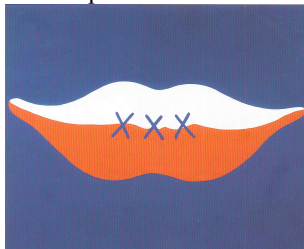

Fig. 4 - Jery Ryszard "Jury" Zieliński, The Smile, or Thirty Years, Ha, Ha Ha 1974. Oil Paint on canvas, 58.5 x 70, Warsaw, Poland. From Frigeri and Morgan 2015.

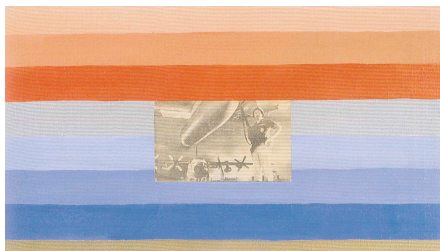

Fig. 5 - Raimo Reinikainen, Sketch 2 for the U.S. Flag 1966. Oil Paint on canvas with newspaper collage, 40 x 65, Helsinki, Finland. From Frigeri and Morgan 2015.

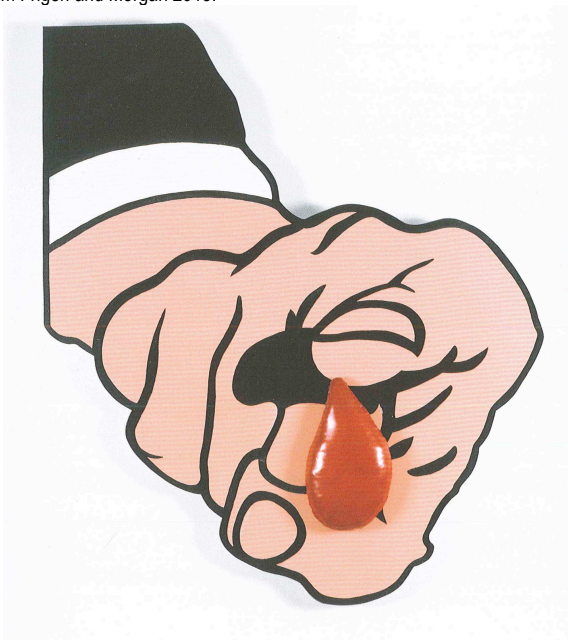

Fig. 6 - Marelo Nitsche, I Want You, 1966. Cotton padded plastic and acrylic paint on PVC, 127 x 106 x 11.6, Sao Paulo, Brazil. From Frigeri and Morgan 2015.



Fig. 7 - Toshio Matsumoto, Mona Lisa, 1973. 16 mm film transferred to digital file, 3 min 50 sec, Nagoya, Japan. From Frigeri and Morgan 2015.



Fig. 8 - Ushio Shirohara, Oiran 1971/2014, Ha, Ha Ha, 1974. Acrylic paint on canvas, 213.4 x 213.4, Japan. From Frigeri and Morgan 2015.

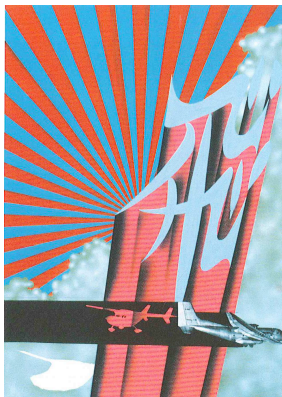

Fig. 9 - Tiger (Kōichi) Tateishi, Hi, 1964. Goache on paper, 64.4 x 44.3, Japan. From Frigeri and Morgan 2015.



Fig. 10 - Judy Chicago, Birth Hood 1965/2011. Sprayed automotive lacquer on car hood, 109 x 109 x 10, EEUU. From Frigeri and Morgan 2015.



Fig. 11 - Ulrike Ottinger, God of War, 1967-8. Triptych, Acrylic paint on wood, 190 x 260 x 60 (open), Germany. From Frigeri and Morgan 2015.



Fig. 12 - Erró, American Interior No 9, 1968. Glycerophtalic paint on blended fabric, 130 x 162 x 2.5, Iceland. From Frigeri and Morgan 2015.



Fig. 13 - Ángela García, *La Cenicienta*, (Series: *Misses y Hadas*), 1974. Collage on Canvas, 150 x 150, Spain. From Frigeri and Morgan 2015.



Fig. 14 - Equipo Crónica, *Socialist Realism and Pop Art in the Batterfield*, 1974. Acrylic paint on canvas, 200 x 200, Spain. From Frigeri and Morgan 2015.

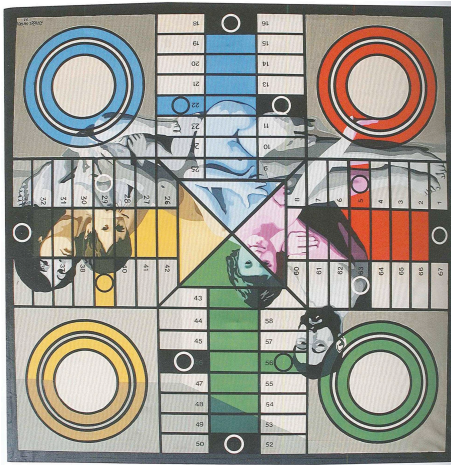

Fig. 15 - Isabel Oliver, The Family from the series The Woman 1970-3. Acrylic paint on canvas, 98 x 98, Spain. From Frigeri and Morgan 2015. From Frigeri and Morgan 2015.

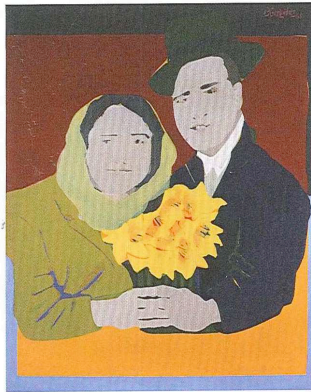

Fig. 16 - Beatriz González, The Sisga Suicides III, 1965. Oil paint on canvas, 120 x 100, Colombia Bogota. From Frigeri and Morgan 2015.



Fig. 17 - Teresa Burga, Cubes, 1968. 6 Objects, painted playwood, Each 40 x 40 x 40, Peru. From Frigeri and Morgan, 2015.



Immersed in the everyday realities of their own environment, artists worked from the local to the global, taking their claims from the context of their countries into a global scope, in a transition that occurred without a previous route map, through a plastic language accepted by the vast majority of artists from around the world.

“From Brazil to Spain, passing through Iran, France, Japan Sweden, Belgium, Finland and Germany, pop art was thriving. While Lippard was setting the canon of Anglo-American pop art a global contingent of artists were engaged with the social and political turmoil of the 1960s” [4]

All this journey is already past, unlike the ideological origins that made it possible; nearly half a century separates us from the creative moment that concerns us.

But going back to the very nature of language, stripping it off its political and communicative sense, if possible, we keep its expressive self and plastic values, regardless of the communicative value; from that point of view, colour is the most obvious element and main protagonist.

Pop looks for bright, intense, high contrast, flat colours, without textures or shades of chiaroscuro. It does not hide its origins, moreover it flaunts its lineage. That is the point of view we are interested in from the analysis and the exhibition.

I consider that such an intense chromatic prominence has not been led by any other language before; although impressionism delivered some gorgeous colours, texture, chiaroscuro, impasto and glazes were involved with the visual message.

Bringing pop closer to our interests, on the occasion of this congress, I believe to be right when I write that the use of colour made by Pop Art provides it with a more intense role than any other artistic movement.

## SERIES MORPHOLOGIES

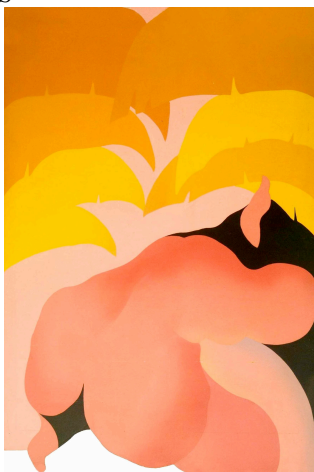

Fig. 18 - Ángela García, *Divertimento* (Series Morphologies), 1973. Acrylic on Canvas and Wood, 150 x 100, Spain. From Frigeri and Morgan (ed.), 2015.

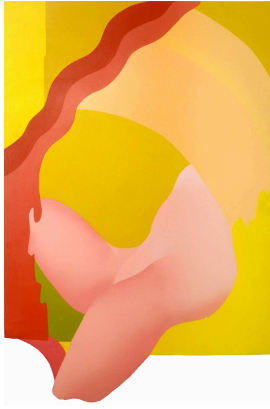

Fig. 19 - Ángela García, *Breathing Out* (Series Morphologies), 1973. Acrylic on Canvas and Wood, 165 x 110, Spain. From Frigeri and Morgan (ed.), 2015.

The technique with which these images have been produced is acrylic paint on canvas which is glued onto the board; it has been necessary to glue the canvas onto the board to maintain the texture of the canvas and, moreover, my intention was to build a compact representation within its own limits, in order to emphasize the joint of the image that I wanted to convey. It can be clearly observed in *Self-Distraktion* (Series Morphologies, 1973); the others only needed trimming at the bottom. I should also note the composition of this picture, where the morphological elements are restructured with an order that differs the standard, what was understood as deconstruction, probably, although my intention was not so much intellectual as need for change.

The technique remains the same, acrylic on canvas, and in these three works I have changed the trimming for the processing of the frame, as shown by the images in which the frame is painted accordingly with the composition willing to trespass the limits of an oppressive and unfair system.

This series is painted with acrylic colors; I used the airbrush to signify the volume in the same "glamorous" way that the pictures of female magazines intentionally emphasize the color appearance of fleshy pink.



Fig. 20 - Ángela García, *Self-Distraktion* (Series Morphologies), 1973. Acrylic on Canvas and Wood, 100 x 100, Spain. From Frigeri and Morgan (ed.), 2015.

## SERIES MISSES AND EMBROIDERY



Fig. 21 - Ángela García, Las hadas y el bordado (Series: Misses), 1974. Acrylic and Collage on Canvas, 100 x 75, Spain. Artist's collection.

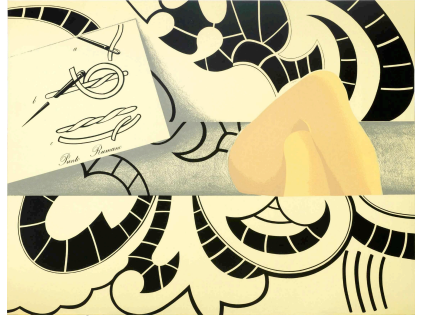

Fig. 22 - Ángela García, Bordados (Series: Misses), 1974. Collage on Paper, 45 x 60 cm, Spain. Artist's collection.



Fig. 23 - Ángela García, Composición (Series: Misses), 1974. Collage on Canvas, 150 x 150 cm, Spain. Artist's collection.

The education received by girls in the 60s swang between docility and good behaviour, and the need to be beautiful and discrete. Embroidery, fairy tales in which the prince meets the beautiful princess was an insistent and repeating script that gravitated polyhedrally above female education; internalised fetishes very hard to fight, especially if we think that women in Spain in the 60s hardly had economic any autonomy and freedom of movement.

With the visual elements of the time, this series was built.

The graphic resource used on this occasion was a composition based on vertical strips where the iconographic discourse was organized. These strips vertically structured work as a collage and both the compositional and conceptual discourse intertwine perfectly showing a pretty adjusted image of what means to be told.



Fig. 24 - Ángela García, Self-Distraction (Serie: Morfologías), 1973. Silkscreen, Pencil and Acrylic on Wood, 70 x 110, Spain. Artist's collection.

As an epilogue.

The history of painting is full of great masters of colour; as individual artists, Matisse or Miró were main figures of modern art who worked masterfully with colour, and as such they figure in the history of painting.

But pop hosted many varied artists from around the world who embraced colour as the undisputed key element in this period of art history.

Ángela García

## References

- [1] F. Frigeri, in F. Frigeri and J. Morgan (edited by), "The World Goes POP", Catalogue of the Exhibition, Tate Modern, 17 September 2015- 24 January 2016, Tate Publishing, 2015.
- [2] F. Frigeri, *ibidem*.
- [3] F. Frigeri, *ibidem*.
- [4] F. Frigeri, *ibidem*.

# From Skeuomorphism to Material Design and back.

## The language of colours in the 2nd generation of mobile interface design.

Letizia Bollini, PhD

Dip. Di Psicologia, Università di Milano-Bicocca, letizia.bollini@unimib.it

### 1. Introduction

As Apple firstly launched iPhone at the beginning of 2007, the first generation of mobile devices rapidly raised using the same interface design approach established by *iOS Human Interface Guidelines* that means *skeuomorphism*. The interface of iOS and Android smartphones were 3D, bold, rounded, coloured, shaded and hyper-metaphorically similar to the real world. As always happened in design field, when something new is introduced into the market, it uses a mimetic approach with the already existing world so that people can easily create a mental model based on their previous experience. Colours were used in a *natural* way to convey a recognizable and reliable image of the world, so realistic to be transparent to the users' perception. The enhancement in 2013 of iOS7 to *flat* design represents a significant breaking point. Quickly implemented and expanded as *material design* in a deeply well-structured Android manual, flat approach has significantly altered the use and the language of colours applied to graphical and touch interfaces both in mobile and desktop operating systems, (responsive) web sites and mobile applications.

On one hand, material design introduces a wide, massive and bold use of colours so that they become one of the most powerful and expressive assets of the interaction in the experience system. But, on the other hand, they assume a connotative and abstract role in identifying elements and in guiding the users across sections, navigations, call-to actions and feedbacks.

### 2. The language of visual design: a strategic asset for user experience

According to new research and design trends in usability and user experience (Ux) studies, the aesthetic value in graphic and multimodal user interfaces (UI) is becoming even more a strategic asset.

The concept of *playfulness* —however not directly related to the interface in itself— is already expressed in the ISO 9241-11:1993 Standard that defines the concept of *usability* in the following way: “This part deals with the extent to which a product can be used by specified users to achieve specified goals with *effectiveness* (Task completion by users), *efficiency* (Task in time) and *satisfaction* (responded by user in term of experience) in a specified context of use (users, tasks, equipment & environments)” [1].

The guideline proposes three parameters to evaluate the usability level of a product: *effectiveness*, *efficiency* e *satisfaction*. Although most methodologies are focused and able to measure the first two, *satisfaction* remains often in the background.

On one hand satisfaction is a qualitative value that can't easily be described with standard or quantitative parameters —such as the number of tasks correctly executed or the time used to complete them— on the other hand it involves a personal *emotional* experience and feed-back.

Kurosu and Kashimura [2] established a first approach defining a new parameter: the *apparent usability* intended as a usability aspect *perceived* by the user “strongly affected by the aesthetic aspect rather than the inherent usability. [...] *Apparent usability* is less created with the *inherent usability* compared to the apparent beauty”. Suggesting to designers to improve the apparent usability they means the *aesthetic aspects* of the interfaces.

This research track was developed by the further studies of Tractinsky, Katz & Ikar [3], Lavie & Tractinsky [4], Rosenfeld & Morville [5] and Donald Norman, both in the paper *Emotion and design: Attractive things work better* [56] and the recent book *Emotional design* [7].

This shift of focus —from *rational* to *emotional* elements— restores the centrality of visual design and its languages, among them, the colours issues.

As stated in the *classical* Garret's diagram [8], the visual design of the interface surface is the *space* where the interaction between digital and people happens. For this reason its language should be strongly connected to every daily user experience, mental models and expectations. Furthermore graphic design applied to digital artefacts —despite having to face a number of specific constraints due to the medium nature— could find in colour a powerful expressive tool not limited —as in printed world— by costs and production limitations (see Zeldman [9] and Postai [10] and Bollini & Greco [11] for a deeper discussion of this issue and the transition from paper to digital communication design).

### 3. Skeuomorphism: the colours of the world

As happened to many design and technologies innovation —moreover in immaterial field— when introduced in mass market, also the new mobile operative systems have adopted a *mimetic* approach to existing material references and/or interface patterns already familiar for the users. Even for *early adopter* —therefore people susceptible and motivated to learn new mind set of interaction according to the *diffusion of innovation theory* by Rogers [12]— the first mobile operating system of the iPhone and its visual and touch interface was based on a metaphor —as happened with the first Apple OS and its GUI designed by Susan Kare— modelled on the real world. A leather-bound diary, a '50s radio microphone, a 3D compass where the icon that once *tapped* —one of the gesture to interact with touch interfaces listed by Villamor, Willis and Wroblewski [13]— launch the applications.

This first generation of mobile OS —which was followed by Android developed by Google and firstly installed on the devices of Apples competitor Samsung— adopted a digital skeuomorph strategy to visual design, or a *skeuomorphism* style “in which certain images and metaphors, like a spiral-bound notebook or stitched leather, are used in software to give people a reassuring real-world reference” as underlined by Wroblewski himself [14].

The term *skeuomorphism* is a compound by the Greek words *skéuos* [σκεῦος]: container or tool and *morphé* [μορφή]: shape, used since 1890 to describe material object and nowadays applied to digital interface as already reported by Gessler in 1998 [15].

If—generally speaking—3D effects, materiality and touch-feeling are the basic design patterns of the representation language of skeuomorph-interfaces, colours and their conceptual use is directly drawn from the world. Elements are rendered through textures and hues or tins which depict explicitly physical objects that are intended to symbolize or, at least, visually synthesize.

according to this *philosophy* the denotative value of colours is limited to few elements which refer to shared semiotics conventions such as the ternary of traffic lights: *red* to warn and alert users when approaching very *dangerous* actions such as *eliminate*, *cancel*, *undo*. On the opposite, *green* to show neutral or positive tasks aimed to finalize standard actions and giving a confirmative feedback.

Unless small semantic blur, the user experiences *transparent*—according to the Bonsiepe conceptualization [15]—for what concerns the chromatic language of the default applications because of their similarity with reality.

The colour and its symbolic meanings, in terms of user experience and interface design, wasn't one of the main elements of the first generation of mobile design.

On the other hand also custom applications or *responsive* version of web sites—a comprehensive modality to decline different versions of the same site or pages to be optimized and displayed on different devices and resolutions screen starting from the same source (see Marcotte [16] for further discussion about *responsiveness*)—colours application guidelines were declined according to institutional brand and corporate image design manuals.

### 3. Flat design: a touch of abstraction

The transition to iOS7 in 2013 [17] ends the pioneer phase of the mobile revolution: new generation of devices have been introduced—not only smartphones but also tablet, phablet, wearables and IoT—new brands have been raised in the market older player in IT and hardware field are missing the wave or definitely disappearing acquired or exhausted being no more able to compete in a new challenging world.

This transition phase represents the required time to normalize the first generation approach, preparing the field for experimenting and addressing further exploration to potentiality and specific features of the devices.

Mobile OS and apps design free themselves from realistic patterns and embrace the new language of the so-called *flat design*. The flat interfaces—bi-dimensional to differentiate from the 3D effects, synesthetic, tactile and shades—find a symbolic and minimal way to communicate to users although maintaining a almost clear *affordance* according to Norman [18] and Bagnara & Broadbent studies [19].

Colour, on the opposite, becomes one of the most important and valuable expressive repertoires in this second generation of UI-touch interfaces. In a even more abstract context the visual language of colours has a connotative, identifying role in telling

stories and let people understand interaction and feed-backs in a playful way.

Although the three main mobile operating systems —iOS, Android and Windows Surface— have different approaches, colours are one of the most valued, well-defined and explored assets in design guideline manuals.

In particular Google creates and launched a document *Material design* [20] in 2014 in which theoretical concepts and principles and practical examples are given and explained to allow pros to better design apps coherent with the whole approach of Android development and framework. In this interactive guide the philosophical perspective is declared and discussed to understand the declination of single principles and in particular of colours choice, use and implementation.

The aim of Google —applied successively to other digital services of the platform not only in mobile ducts— is to create a visual language that “synthesizes the classic principles of good design with the innovation and possibility of technology and science” but the declared *material metaphor* has a very different interpretation compared to skeuomorphism. It grounds in *tactile reality*, inspired by *study of paper and Ink*, but “yet open to imagination and magic.” But the concept of materiality, in this new context, means multi-layered, tactile, 2-dimensionals, flat, geometrical surfaces barely differentiated by lightning effects and animations. Dramatic changes of bold background colours indicate space articulations or subdivisions and cognitive organization of the interface structure.

In the absence of more explicit references to patterns or systems already known by the user the visual grammar and the language of graphic design become the conceptual tools to create the new imaginary as declared: in the fifth principle of the nine conceptual premises: “Content is bold, graphic, and intentional: bold design creates hierarchy, meaning, and focus. Deliberate color choices, edge-to-edge imagery, large-scale typography, and intentional white space create immersion and clarity.”

In the end, *flat* firstly and *material design* next introduces a bold use of colors in a very abstract and connotative way. Colorus become “unnatural”, saturated, vivid, acid. Contrasts are strong and effective and they become one of the main expressive assets of the mobile interface design.



Fig. 1 - iOS 7: *skeuomorph* vs. *flat* icon and built-in application UI: visual comparison.



Nevertheless, some of the established pattern- semiotic- and cultural-meanings — coming both from Gestalt Theory and basic design— are disregarded creating misunderstandings and errors in the users experience.

#### 4. The unique colours language three different approaches

As previously underlined all the three main second-generation mobile operating systems converge on colours language and its modulations to convey identity, hierarchy, coherence and feedbacks to the users when interacting with the system itself and commercial apps. Although the starting point is common, the design philosophy, the whole look & feel and the final results are significantly different.

##### 4.1. Colours language according to Apple-iOS

At its very first launch, flat design of iOS 7 was mainly concerned with simplification of the whole user experience both in emotional and mental model and in technical aspects. Loosing 3D and shaded effects, the vintage look and the dark, heavy metaphor referring to the ‘50s object almost unknown to the younger *digital natives* and *millennials* generations immediately gives a new perspective.

As reported by Matt Gemmell in a deep-debated and well-documented post “iOS 7 is much, much lighter - in the colour sense, and consequently also in visual weight. Breathable whitespace is everywhere, and is used to unify... The overall impression is of brightness and openness. iOS 7’s new look is bold, opinionated and readable.” [21]. So, the new wave of bi-dimensional visual elements, surrounded by a wide amount of white negative space let the chromatic choices speaking loudly, although not always clearly. According to the UI Design Basics section of the iOS Human Interface Guideline released by Apple “Let color simplify the UI. A key color — such as yellow in Notes— highlights important state information and subtly indicates interactivity. It also gives an app a consistent visual theme.

The built-in apps use a family of pure, clean system colors that look good at every tint and on both dark and light backgrounds.” Embracing the flat philosophy, also means to use bold, well-defined coloured shape to identify buttons, call to actions or interactive portions of the interfaces: “In content areas, a borderless button uses context, color, and a call-to-action title to indicate interactivity. And when it makes sense, a content-area button can display a thin border or tinted background that makes it distinctive.”

Colour becomes, therefor, the key-element to build interface affordance and meaning —as visually described by figure 2— and, at the same time, to build an emotional connection with users.



Fig. 2 - iOS 7: flat design look & feel of built-in applications' icons. [from iOS Human Interface Guideline].

The colours family proposed (see figure 3) is a palette of strong, pure, clean, saturated colours with *effective personality* which works well both with dark or light backgrounds or other combinations in a *colours enhanced communication perspective*.

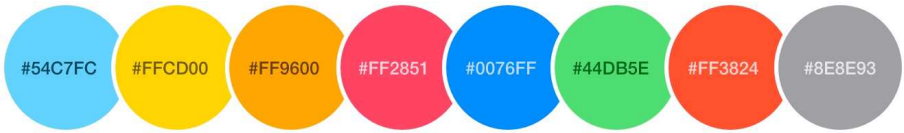

Fig. 3- iOS 7: main colours palette for built-in and other applications. [from iOS Human Interface Guideline].

Furthermore coordination and contrast become the main paths to investigate and experiment when working and designing custom applications. A balanced asset of the colors language – a range of pastel colours or, on the contrary, strong colors for example— on one hand or a sufficient-well-contrasted juxtaposition between fore- and background. [22] Nevertheless this *trust* in colours as the unique or, at list, the main way to identify and decline all the visual and interactive elements of the built-in apps risks to create an ambiguous and inefficient user experience.

If basic design principles of the colour language are misused or *forgotten*. One of the more evident problem is well visible in the calendar build-in app. The identifying colour of this function applied to all the elements of the interface is red. Every visual message is given by using red, even if they positive messages whether negative.

*Add* is red as well as *delete* (see figure 4) although they have opposite meaning and functions deliberately ignoring the semiotic triad of red/yellow/green well embedded in the every-day experience of the user and/or the basic design principles and meaning deeply grounded in our culture.

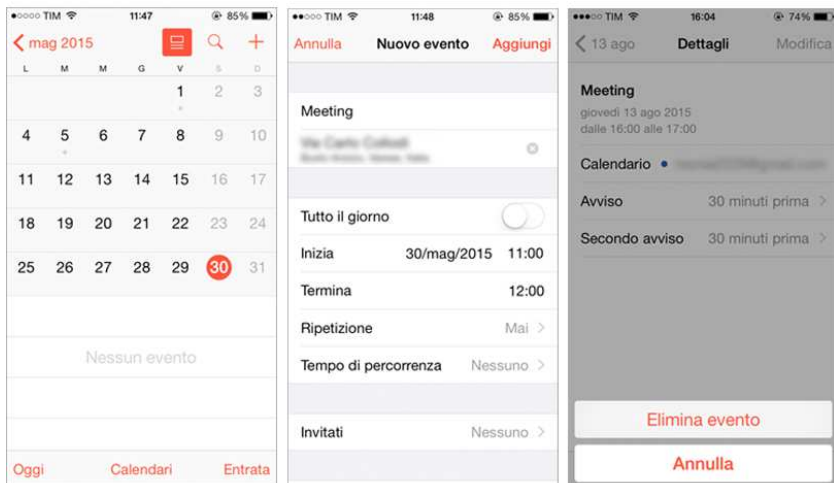

Fig. 4- iOS 7: Calendar interfaces and task sequence “add/delete an event”.

Only to resume this language in other applications which have a different identifying colors such as in *mail*—characterized by the use of cyan (see figure 5)— where *red* is now the alerting chromatic element to warn user in doing *dangerous* procedures.

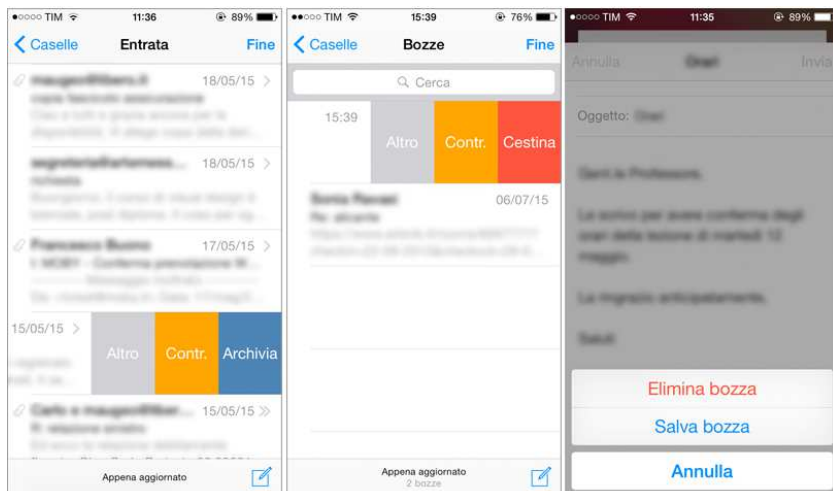

Fig. 5- iOS 7: Mail interfaces and task sequence “archive/delete an email”.

For wider and detailed examination of the problem see the paper previously presented and discussed at the *X Conferenza del Colore* in 2014 [23].

#### 4.2. Colours language according to Google-Android

Android coming after the *flat revolution* of iOS 7 reinforces and makes dramatically extreme the use—and abuse!— of colours language. In its design guidelines defines three different ways to choose and articulate a palette: *primary*, *secondary* and *accent* colours, suggesting to “Limit your selection of colors to three hues from the primary palette and one accent color from the secondary palette”. The first one should represent the chromatic brand identity of the application and should be chosen among the bold primary color palette proposed by Android, when possible. The second one should guarantee enough contrast in term of hue and luminosity and declined in lighter or darker tints. Accent colors have a highlight function and should be limited to “floating action button and interactive elements, such as: Text fields and cursors; Text selection; Progress bars; Selection controls, buttons, and sliders; Links” that means to interactive and significant elements in the user perception and experience as exemplified in figure 6. [22]

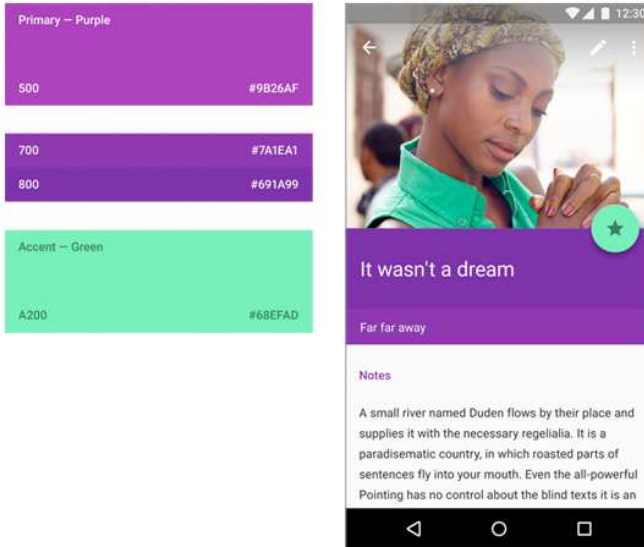

Fig. 6 - Android: how to choose and use a triadic colours scheme according to Material Design Guidelines. [Google, Material Design Guidelines, Style: colors]

Google gives also explicit indications in using chromatic contrast for foreground elements and backgrounds according to the surface layering metaphor described in the main principles. Opacity becomes one of the variation strategies suggested to convey hierarchy or importance relationships among contents, spaces and visual elements. Design directions are given both for text and icon placement on coloured shapes or backgrounds suggesting to use opacity instead of grey or hue/tint modulation of foreground object to guarantee legibility and perceptive discriminations of fonts and pictograms.

Although all these precise indications material design too seems to fail in using basic design principle in built-in apps when using colours as distinctive elements. As shown in figure 7, Android chooses —on the opposite of Apple— *green* as calendar app main connotation incurring in the same error. In this case main messages are *green*, but the accent hue for *add* bottom is depicted with a dystonic *red*. And, the negative call to actions *undo* and *cancel* adopt a reassuring *green*.

Android is credited to have tried to give deep and well organized guideline bringing UI design back to its guest role and cultural origins rooted in graphic design culture, nevertheless it seems to miss the *big picture* which lies under every project and the basic *common sense* both of every day life and of usable and *friendly* interfaces. The final result seems more a *style* exercise rather than a *concrete* result.

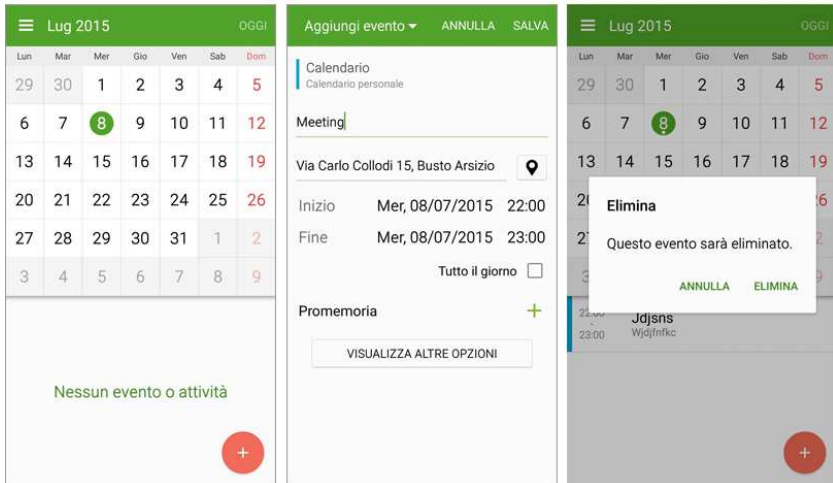

Fig. 7- Android: Calendar interfaces and task sequence “add/delete an event”.

### 4.3. Colours language according to Windows-Surface

Microsoft deserves a separate discussion. Although it arrived late in mobile technologies field, it tried to create its own niche to differentiate its products and services from competitors. Microsoft remains probably the only market player who is not directly producing a device —at least smartphones— but using its dominant position in the field of desktop operating systems to create a whole *world* of cross-services and experiences where boundaries between smartphone, tablet, netbook, notebook and desktop is no more relevant. The breaking point and represented by *Surface* in 2008 become a tablet-line in 2012: a new multi-touch interface paradigm totally different from iOS and the simulative approach of Android.

As Microsoft declares in its Developer resources for Windows App the philosophy that inspires the interface design in its different elements is, above all, *simplicity* the same *minimal* principle of the *flat* revolution: “We believe in timeless principles of good design inspired by the International Typographic Style that emphasize simplicity, clarity and universality to achieve beautiful and practical experiences. Grid, Type, Color, Icons and other elements are related to each other in deep and meaningful ways. The mathematical relationship between the basic components enables order, beauty, harmony, clear hierarchy and flexibility, allowing expressive designs or functional experiences. [...] Our goal is to define one design language that is familiar and persistent across Microsoft ecosystem.” [24]

The colours choice for UWP (*Universal Windows Platform*) Apps are rigorously settled both in a theoretical way and in a practical ones.

The design logical is described by the statement: “Color provides intuitive wayfinding through an app’s various levels of information and serves as a crucial tool for

reinforcing the interaction model.” According to this principle colours have to be selected as a *single accent* among 48 possible hues and composed with *colour selections*, that means, light and dark shades of the accent color are created based on HCL values of color luminosity to create a strong chromatic hierarchy and clear visual interaction signals.

Furthermore Windows introduced another original concepts in managing colors as a user experience resource: *colour themes* a set *positive* or *negative* —in terms of hue and contrast— palette —at the moment limited to smartphone applications— among which the user can customize his or her visual interface (see figure 8). The Design Guidelines suggest that: “Apps using light theme are for scenarios involving productivity apps. Examples would be the suite of apps available with Microsoft Office. Light theme affords the ease of reading long lengths of text in conjunction with prolonged periods of time-at-task. Dark theme allows more visible contrast of content for apps that are media centric or scenarios where users are presented with an abundance of videos or imagery. In these scenarios, reading is not necessarily the primary task, though a movie watching experience might be, and shown under low-light ambient conditions.” [25]

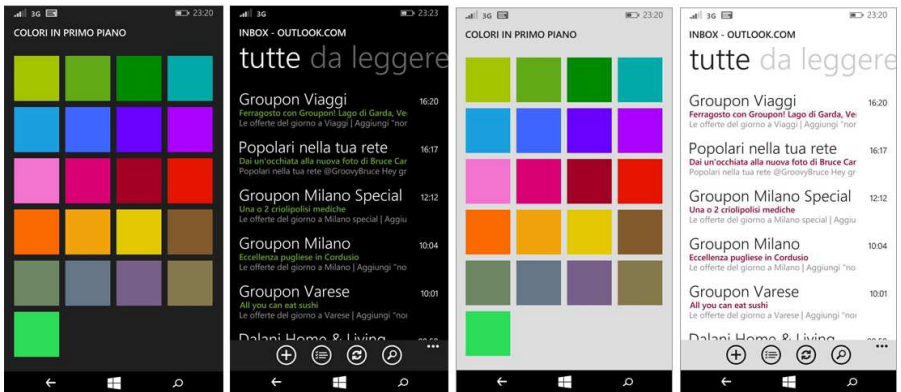

Fig. 8 – Windows Universal Windows Platform App accent colours palette and dark/light colours themes [Windows Dev Center]

The Windows approach differs totally from its competitors when applied to single built-in applications. Using the calendar/agenda app to compare the user experience as already done for iOS7/*flat* and Android/*material* design the first evidence is that colours are not the way to convey interactive actions and messages to the user. *Save*, *add* or *delete* call-to-action are visualized using icons instead of colours. The obsolete floppy-disk symbol and an “X” tell the user what to do. Not colours. The graphical interface is solved just using black & white elements both visual and textual and shapes to cluster, differentiate or isolate the interactive triggers as shown in figure 9.

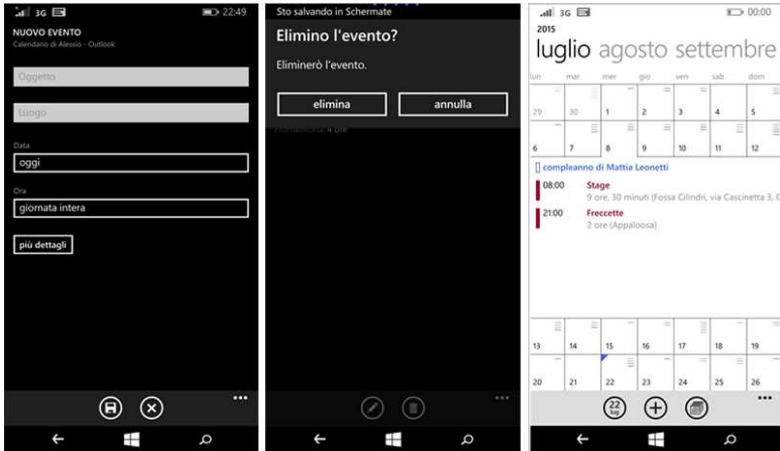

Fig. 9 – Windows: Calendar interfaces and task sequence “add/delete an event” dark and light theme.

The single coloured elements —purple and blue in the given example of figure 9— are chosen by the user who can customize his/her own visual glossary according to a personal mental model. Unlike the other mobile operating systems, Windows gives on/off/highlights feed-back state up.

## 5. Conclusions

The transition between first and second generations of mobile operating systems represents a huge revolution in the language of user interface design that reinforces and gives a central role to colours language in creating affordance, hierarchy and visual cue to distinguish interactive elements.

If skeuomorphism was keen to simulate the real world to reassure people giving a well recognizable transposition of their mental habits and knowledge the minimal approach of *flat/material* design breaks this reassuring scenarios and assigning new roles and meaning in project strategies.

Colours become, then, the main driver in building the meanings, the cognitive model and a vivid, clear, playful experience to users. Design guidelines give and assure an explicit and specific function to primary, secondary and highlights chromatic elements intentionally building a grammar, a syntax and a semiotic structure to colours language. The operating systems proposed colour palette —selected among vivid, bold, artificial hue— are the shared vocabulary where design and experience find the common ground and an new *idiomatic* way to express visual concepts and interactions. Colours become the *play makers* of the user experience, On the other hand designers should remember and consciously use —in this new abstract declination of hue, tints and de/saturations— the symbolic logic and meanings already embedded in the users’ mind and in the everyday experience.

## Bibliografia

1. [http://www.userfocus.co.uk/articles/ISO9241\\_update.html](http://www.userfocus.co.uk/articles/ISO9241_update.html) [Last visited: 1st April 2016]
2. M. Kurosu, and K. Kashimura. "Apparent usability vs. inherent usability: experimental analysis on the determinants of the apparent usability." Conference companion on Human factors in computing systems. ACM, 1995.
3. N. Tractinsky, A. S. Katz, and D. Ikar, "What is beautiful is usable." *Interacting with computers* 13.2 (2000): 127-145.
4. T. Lavie and N. Tractinsky, "Assessing dimensions of perceived visual aesthetics of web sites." *International journal of human-computer studies* 60.3 (2004): 269-298.
5. L. Rosenfeld, P. Morville, "Information architecture for the world wide web." O'Reilly Media, 2002.
6. D. Norman, "Emotion & design: attractive things work better." *interactions* 9.4 (2002): 36-42.
7. D. Norman, "Emotional design: Why we love (or hate) everyday things" Basic books, 2004.
8. J. J. Garret, "The Elements of User Experience: User-Centered Design for the Web and Beyond (Voices That Matter)" 2nd Ed., New Riders, 2010
9. J. Zeldman, "Dalla carta al Web: istruzioni per l'uso per designer di talento" Hops, 2001.
10. S. Postai, "Siti che funzionano 2.0." *Tecniche Nuove*, 2004.
11. L. Bollini and M. Greco, "Organizzare presentazioni efficaci." Hoepli, 2008
12. E. M. Rogers, "Diffusion of Innovation" (1st ed.), Free Press of Glencoe OCLC 254636, 1962
13. C. Villamor, D. Willis and L. Wroblewski, *Touch Gesture Reference Guide*. 15th April 2010 <http://www.lukew.com/ff/entry.asp?1071> [Last visited: 1st April 2016]
14. L. Wroblewski, "Mobile first" A Book Apart, 2011
15. N. Gessler, "Skeuomorphs and Cultural Algorithms" in *Proceeding of the 7th International Conference on Evolutionary Programming VII*, pp. 229-238, Springer-Verlag, 1998
16. E. Marcotte, "Responsive web design", A List Apart n. 306, 25th May 2010 <http://alistapart.com/article/responsive-web-design> [Last visited: 1/4/2016]
17. N. Wingfield and N. Bilton, "Apple shake-up could lead to design shift", *The New York Times*, 31st October 2012. <http://nyti.ms/QVp6vc> [Last visited: 1/4/2016]
18. D. Norman, "Affordances and Design". [http://www.jnd.org/dn.mss/affordances\\_and.html](http://www.jnd.org/dn.mss/affordances_and.html) [Last visited: 1/4/2016]
19. S. Bagnara and S. Broadbent, "Comunicare con artefatti cognitive" in G. Anceschi, "Il progetto delle interfacce: oggetti colloquiali e protesi virtuali" Domus Academy, 1993
20. Google, "Material Design", 2014 <https://www.google.com/design/spec/material-design/introduction.html> [Last visited: 1/4/2016]
21. Matt Gemmell, "iOS 7", 12nd June 2013. <http://mattgemmell.com/ios-7/> [Last visited: 1/4/2016]
22. "Apple iOS Human Interface Design Guideline". [https://developer.apple.com/library/ios/documentation/UserExperience/Conceptual/MobileHIG/index.html?utm\\_source=twitterfeed&utm\\_medium=twitter](https://developer.apple.com/library/ios/documentation/UserExperience/Conceptual/MobileHIG/index.html?utm_source=twitterfeed&utm_medium=twitter) [Last visited: 1/4/2016]
23. L. Bollini, "Topos vs. Iris. Colour design in Web 3.0 mobile app and OS: a critical review." In M. Rossi (Ed.), *X Conferenza del Colore. Vol. X B*, pp. 365-372, Maggioli Editore, 2014
24. Microsoft, Developer resources. Windows App: Design & UI. <https://developer.microsoft.com/en-us/windows/design> [Last visited: 1/4/2016]
25. M. Jacobs, Microsoft, Developer resources. Windows App: Color for UWP apps, Last Updated: 14<sup>th</sup> April 2016. <https://msdn.microsoft.com/windows/uwp/style/color> [Last visited: 17/4/2016]



# “Out of the blue Foam”. MVRDV’s Didden Village as a full-scale model

Fabio Colonnese

Dept. History, Drawing, and Restoration of Architecture, Sapienza Univ. of Rome, [fabio.colonnese@uniroma1.it](mailto:fabio.colonnese@uniroma1.it)

“Imagine a building exactly like the Pantheon, except pink—the Pink Pantheon. The perspectival appearance of spatial properties produced by the Pink Pantheon and by the normal Pantheon would be the same. But there would be a significant aesthetic difference.”

Nick Zangwill, *Aesthetic/Sensory Dependence*, 1998

“What is it?” asked the neighbors.

“A color,” said the wizard. “I call it blue.”

“Please,” cried the neighbors, “please give us some.”

And that was how the Great Blueness came to be. After a short time everything in the world was blue.

Arnold Lobel, *The Great Blueness and other Predications*, 1968

## 1. Introduction

In the late sixties of the last century, architects interpreted a generalized appeal to realism – a word in itself susceptible of interpretation – in different forms. They oscillated from the post-modernist way, which relies on the narrative method and quotes images of the past in purely visual and formal schemes, to the neo-rationalist which searches the historical architecture of the abstract operational categories of universal value [1]. This debate resulted in both a sort of declaration of independence from the mere social constructive mission of architecture and to a self-referencing to the discipline, which also favored a reassessment of the architectural representation as autonomous pseudo-artistic expression. This shift had consequences in many fields, from the spread of specialized galleries for exhibitions of architectural drawings and models to that of specific studies on designs, from sketches on travel notebooks to photomontages; but important consequences can also be found in the idea of project. Peter Eisenman’s *House of Cards* or Venturi & Scott-Brown’s monument to Benjamin Franklin in Philadelphia, whose house is evoked through a metal frame that traces the edges like a full-scale cartoon-like model, testify a new taste for architecture as staging, as a representation in itself, as a citation of graphical models and models needed for its definition and construction. This game to move or conceal the threshold between reality and representation [2] has produced a kind of aesthetics of the model that has been alimented by the digital revolution and the diffusion of the innovative tools and procedures for the production of photo-realistic images.

Such aesthetics of the model [3] can be pursued not only through hierarchical and construction aspects of the structure but also through the formal abstraction an architect can deliberately assume to amplify the ambiguity and actively involve the viewer. This is the case of architecture inspired by the neoplastic principles of plane decomposition and coloration, which can share with the models qualities such as abstraction, apparent lability, reversibility, exterior prominence, and structural

empiricism. From the first photographs, the “approximate” Rem Koolhaas’ Villa Dall’Ava would even been mistaken for a full-scale model [4] while the pictures of the twisted steel rods of Frank Gehry’s Guggenheim Museum in Bilbao could not help but reminding a sort of huge study *maquette* to empirically support the metallic cladding.

In the last decades, this phenomenon has become an expressive interpretation of those architects who have become aware and have learned to manage and to expand the semantic and emotional quality of their projects, as in the case of MVRDV, also due to their innovative use of color.

## 2. MVRDV’s design process

For almost two decades, Rotterdam based MVRDV firm – an acronym designated by the surname’s initials of Winy Maas, Jacob van Rijs, Nathalie de Vries, its three founders – is known for provocative, creative, and imaginative tone of the architectural proposals. Their symbolic and experimental use of color often became the outstanding touch that integrates simple architectural volumes, sometimes with unpredictable consequences. The most famous episode is concerning the (formerly) Orange House in Amsterdam (2001). It is a 60x26x23-foot-high box built into the courtyard of a residential building as the result from a low budget, a zoning plan that dictated the maximum height and the program arranged by a couple of graphic designers. Despite MVRDV’s proposal to have it painted bright blue, the studio was painted orange, the warm color requested by the clients to have also a suggestion of brick about it, which gives the building mass” [5]. However, after it was completed, other residents started to complain about the disturbing orange reflections in their houses and engaged lawyers, press, and television to have it changed. After some disappointing episodes, “the municipality decided to pay half the cost of repainting of the house (green) and that the owner would pay the rest, if the owner would be happy with an official living permission (a permit)” [6].

As learnt while working at OMA in Nineties [7], MVRDV’s design process happens mainly thorough various scale models that constitute the major cognitive tools in the design process. To emphasise their abstract character, concept models are usually realized in a single material. The technique of modelling influences design, of course, and Foam (a Polyurethane cast of an aggregate condition between solid and void) allows designers to generate shapes that cannot be produced with other materials. Foam is soft, direct and versatile, easy to shape, to test and discard as many ideas as possible in a short time. Model-makers must not have a defined geometric idea in their mind as for a cardboard or a digital model. As Albena Yaneva confessed, “if you desperately want to find a smart idea, you go cutting foam (...). Foam cutting is the perfect medium for rapid thinking, allowing them to imagine the new shape in the moment of cutting instead of anticipating in advance” [8]. Foam models spark designers’ imagination much more then computer models usually do and occasionally favour fecund misinterpretations and mistakes that are accepted and possibly encouraged as a basic component of a design process in which “reusing, recollecting, reinterpreting, adapting, remaking (...) are all synonyms for creating” [9]. A ludic approach often prevails while arranging a model: it is shifted and rotated in the air, like a toy while his interior voids are

inspected like a doll house. Models seem to possess a sort of magnetic field attracting exogenous energies and elements, as a design choice is something strictly related to being surprised by own work. “There is something mystic in design that surprises the maker, that makes her stand and stroll and dance in the space with the model in her hands” [10].

### **3. “Il est ne pas un *photoshop* que je montre à vous”**

Like most of MVRDV’s projects, the Didden Village (2002-06) has been mainly conceived and presented through Foam models. It is an extension built on the flat roof of a traditional terraced house of the late nineteenth century in the center of Rotterdam. It consists of two concrete volumes that add about 45 sqm to the house and are surrounded by 120 sqm of outdoor area enclosed by an opaque two meters tall wall with horizontal windows (fig.1a). The outdoor areas are furnished with two cylindrical flower boxes and tables with benches. The volume covered by a gable roof contains two rooms of the children with beds on a mezzanine accessible by ladders. The two volumes are connected downstairs with two double helical staircases inserted in opaque iron cylinders [11].

MVRDV had to take in account there was little time to complete such an intervention because the city of Rotterdam was about to be included in a list of protected monuments. This deadline has affected the simplified design of the architectural volumes, the massive prefabrication of building elements, their arrangement by means of a crane placing the parts to be assembled and, in part, also the choice of a unique color unifying all and able to mask the inevitable imperfections quickly and effectively. It only took four days to put this “crown on top of a monument”, where the crown is the new construction and the monument is the traditional building below it.

The interior of the bedroom is fully painted red while the rooms of the children are covered with yellow wooden panels but it is obviously the blue hue of all exterior surfaces to characterize this small architectural intervention. Passers-by down the road can see just its blue perimeter wall but the photographs of the realization induce an alienating effect. One cannot but think of a fiction, a montage that produces a kind of continue renegotiation between reality and fiction, between Magritte’s *The Infinite Recognition* (1963) and *The Truman Show* ending (fig.2b). It is no coincidence that in 2008, introducing the slides the conference held at the Pavilion de l’Arsenal in Paris, Winy Maas told the audience: “Il est ne pas a photoshop que je montre à vous” [12].

### **4. “Le Toit-Village”**

The association between a basic-form architecture and a saturated hue constitutes a recurrent formula in the production of MVRDV, as well as the idea of differentiating chromatically the pieces that ideally constitute their composite architectures, like Mirador in Madrid (2001) or Housing Silo in Amsterdam (2005). Either inspired to stacked containers or Lego constructions (fig.2d), this strategy puts in scene not only the industrial assembly criteria but also the idea of montage [13], which is paradigmatically expressed at all levels. Montage is reflected: in the general conception of a clearly distinguished expansion to preexisting; in representing the

project (in particular the exploded isometric view reminds the assembly instruction of a Lego box, fig.1b); in its implementation, due to the massive prefabrication of the parties; in the perception of a foreign object in the environment, largely influenced by the choice of colors.

The iconography of the “house onto the house” or the “village on top of a building” has several precedents. The idea of using the roofs of the city as an artificial platform belongs to Futuristic urban visions, such as Virgilio Marchi’s designs. The (modernist) house with a garden on the top of the skyscraper in Max Fleisher’s *Mr. Bug Goes to Town* (1941, fig.2c) is a symptom of a general aspiration to intend the city as a place for a new negotiation between men and nature, whose effects can be appreciated up to Pixar’s *Up* (2009). On the other hand, the idea of living in a cottage on top of the roofs of a big city, in a sort of Arcadian compromise between nature and artifice, still embodies the dreams of many, as reported by New York chronicles [14].

In the case of the Didden Village, where vernacular forms seem to seek for a dialogue with the existing buildings, the color and the manner it is used instead produce a remarkable contrast with the city and with its brick and stone skin. The perception of the archetypical wooden houses is totally driven by their very monochromatic surface, which apparently weld them to the ground and the wall all around. The meticulously monochromatic choice, combined with the almost sculptural definition of volumes that are practically free of any obvious constructive architectural details, gives unity to all surfaces, implicitly demonstrating its constructive process of object fell from the sky. At the same time the gradation of cyan blue choose between at least four samples tested, could suggest a mimetic aspiration. However, the latitude conditions and the everyday gray and cloudy skies of Netherland would frustrate such an intent to disappear virtually in the blue of the sky.

The blue, or rather the blue-cyan, complementary to red and yellow chosen for the interiors, appears rather a color chosen for its the scarce occurrence in the urban landscape or, better said, for its obvious artificiality. Among the many possible levels of interpretation, three subtly intertwined keys lead respectively to art, imagination and representation.

## **5. “The Great Blueness and Other Pre-figurations”**

When Nick Zangwill used the upper quoted example of the “Pink Pantheon” to demonstrate that “the aesthetic properties of a work of architecture depend on both spatial and sensory properties in a mutually dependent fashion” [15], he probably did not imagine his provocation could become true few years later.

Blue transforms an everyday object such as the two archetypical houses into something extraordinary and spiritual. Such a lesson can be drawn from the experience of Yves Klein, the “Messenger of the Age of Space”, for his use of the Klein Blue paint on everyday objects and artworks as an attempt to evoke the immateriality, or rather, the liberation of the spirit from the material [16].

Marco Navarra highlighted the seductive character of the project related to the “fairytale tone of the azure blue veil, that enwraps everything and creates wonder and bewilderment” [17] and indeed there are many elements that contribute to the

idea that the Didden Village was conceived as a magical castle in the clouds. Much of the expansion is destined to children and the presence of a playful and fantastic component appears undeniable and, at the same time justified. This may have influenced the bright colors but also the double-helix staircases, which Winy Maas directly link to that of the Chateau of Chambord [18]: undeniably, they help to create a dense network of interwoven and unconventional paths between the various levels and environments, including migration on the roofs through the skylights.

Other indirect references could be found in Arnold Lobel's *The Great Blueness and other Predications*. Finding his village and residents sad and gray, a powerful wizard created and donated them some blue color with which they covered houses, clothes, objects and even animals: "And that was how the Great Blueness came to be. After a short time everything in the world was blue" [19]. Indeed, Lobel's poetic fable could constitute a sort of underground plot of the project. This would be confirmed by the presence of both a spiral staircase, similar to the one the wizard uses to go down to his underground laboratory, and the use of red and yellow in the interior, which were created by the wizard after the blue (fig.2a). Moreover, such an idea would recall the ancestral identity between artist and magician [20], like in the myth of Daedalus [21]. As highlighted by Walter Benjamin, the painter works like a magician: someone who "maintains the natural distance between himself and the patient; though he reduces it very slightly by the laying on of hands, he greatly increases it by virtue of his authority" [22].

Surely, the Didden Village is linked to the idea of representation, staging, fiction. Similar to Oldenburg and Van Bruggen's ordinary objects depicted in monumental scale, it is as conceived and built as it were a model, a full-scale *maquette* temporarily resting onto Rotterdam roofs, transformed into a monumental podium. Thanks to the archetypal form, the simplification of details and the monochrome aspect, MVRDV claim it is a prototype for other interventions through which not only to expand individual buildings but also to plan urban "densification". The Didden Village paradigmatically illustrates their ideas about intervention in the historical city. Therefore, it can be associated to the (formerly) Orange house as well as to the famous WoZoCo as strategies to fill empty spaces and extend apartments in collective residential buildings. As evidenced by Navarra, "Didden Village does not limit itself to a generic extension of hypothesis, but it suggests a transformation that, starting from the inside of a single architecture, can circulate like a virus, using the resources of the organism as a guest for the renewing of the entire body of the city" [23]. As a corollary, the color becomes a possible perceptual key to read the urban scale of the expansion work as a network of extraneous objects placed on roof as well as to highlight the idea of urban development itself.

## **6. "The Blue Mark" or the color of prefiguration**

To highlight the huge potential of all that temporarily occupied space in the Netherlands, during the twelfth Venice Architecture Biennale in 2010, the Netherlands Architecture Institute (NAI) and Rietveld Landscape conceived the exhibition *Vacant NL*, whose main feature was a blue-Foam model city suspended in the top half of the Dutch pavilion (fig.3a). Visitors entering the pavilion passed under the large model with few clues about its actual form and function. Only after

ascending to the mezzanine, they could discover the cityscape from above and discover the sense of the installation as a representation of existing potentials of Dutch urban areas.

In 2012, MVRDV themselves made something similar in Bordeaux to show the master plan for the 35-hectare Bastide Niel development (fig.3c). Blue-painted metallic miniature buildings were erected on the opposite side of the river on top of the *Miroir d'Eau*, or “water mirror” fountain, which caused clouds of mist to rise up and surround the exhibition while Tennis umpires’ chairs around the edges provided a viewpoint over the rooftops, like after stepping up a medieval town in an historical center.

These applications are symptomatic of the role concept models have gained in recent years, passing from the formal definition to communication. They both go beyond the simple representation of a project, adopting the model to put-in-scene an event, a sensorial experience engaging body and mind, a sort of epiphany of future. The early mysterious vision of the model either from below or in the midst of the vapor, is functional to its full discover from a vantage point to be reached after a sort of initiatory route. This is not too different from the Didden Village experience itself, which can innovate the perception of an entire city as predicted by Jörn Utzon years ago [24].

These applications also underline the blue Foam models seem to embody today the idea of planning. Like a manifesto, their blue skin stands for a not-yet-defined materiality of a future building, like in a sort of cinematic Blue Screen. Lacking any visible quality of the materials, the reification process is suspended. The concept models only advice the transformation process has begun, returning the observer’s gaze to the architect. Already Leon Battista Alberti recommended “that the models are not accurately finished, refined, and highly decorated, but plain and simple, so that they demonstrate the ingenuity of him who conceived the idea, and not the skill of the one who fabricated the model” [25]. At the same time, beyond the many controversial cultural acceptations of this color [26], in the design process blue is literally the color of the space as perceived by men, relating with the concepts of incommensurable, limitless, and available to be occupied.

Thus, blue Foam models have become part of the iconography of the contemporary architect who prefers to appear no more as a cultured person in a refined wood-cladded studio but as a relaxed artisan working. While in the mid-sixteenth century, the Dutch Marten van Heemskerck had imposed the iconography of the artist’s self-portrait before the ruined Colosseum [27], MVRDV’s Winy Maas would rather appear with blue Foam models surrounding him. This is confirmed, for example, by the video in which he outlines his ideas on the future development of the Grand Paris, shot in MVRDV office with models in blue Foam in both the foreground table and the background metal stacks [28]. As a sort of symbolic reference, the blue color distinguishes the additions from existing parts even in the renderings after digital models shown in the presentation (fig.3b).

In the end, MVRDV’s choice of a blue-cyan village-like addiction can be mainly attributed to the meaning of “prefiguration of the project” that blue color has acquired from the massive use of blue Foam models in contemporary architectural offices.

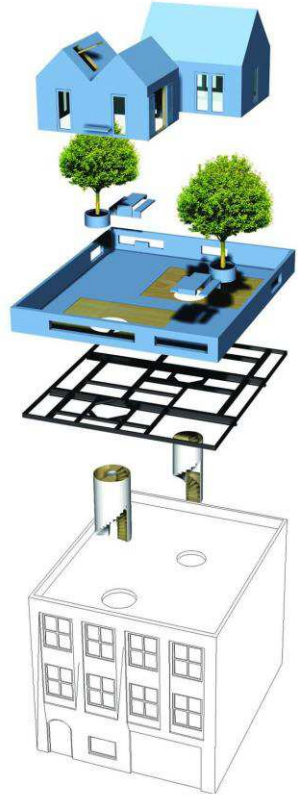

Fig. 1 – MVRDV, Didden Village, Rotterdam, 2002-06. a. Views of the building. b. Exploded axonometric view with constructive layers. From below: the existing house; the two double helical staircases; the horizontal structure; the “tray” with trees and built-in furnishings; the two huts. Photo and drawing: Courtesy of MVRDV.

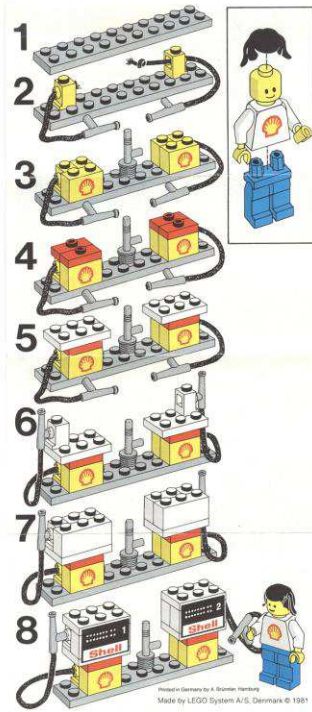
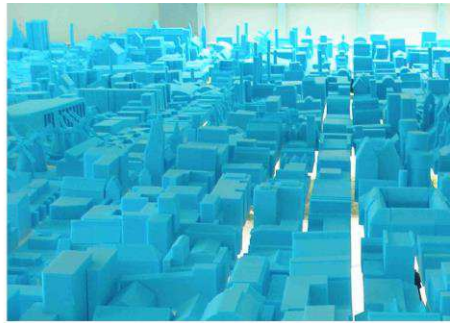

Fig. 2 – From above: a. A. Lobel, *The Great Blueness*, 1968: the wizard painting his own house and the red version of his staircase to dungeon; b. P. Weir, *The Truman Show*, 1998: a final shot; c. M. Fleischer, *Mr. Bug goes to Town*, 1941: the dream of the village upon the skyscraper; d. LEGO's instruction to build, axonometric view, 1981.





SUPER SORBONNE



ET SI GRANDPARIS DEVENAIT LA VILLE LA PLUS COMPACTE AU MONDE ?  
(LE CUBE)

218 KM  
6 X 6 KM



Fig. 3 – From above: a.NAI & Rietveld Landscape, *Vacant NL*, XII Venice Architecture Biennale, 2010: views of the foam model from below and above; b. W. Maas, *Grand Paris 10*. MVRDV avec ACS et AAF, 2010: two renderings from digital models and W. Maas talking between models; c. MVRDV, *Model of Bastide Niel development*, Bordeaux, 2012. Courtesy of MVRDV.

## References

---

- [1] B. Reichlin, and M. Steinmann (Editors), *Realismus in Der Architektur/Realisme Dans L'architecture, Archithese Heft*, n.19, 1976.
- [2] R. Hubert, "The Ruins of Representation", in *Idea as Model*, K. Frampton, S. Kolbowski (Editors), New York, 1981, pp. 16-27.
- [3] F. Colonnese, "Die Erfahrung mit lebensgroßen Modellen im Entwurfsprozess", in *Manifestationen im Entwurf in Architektur, Design und Ingenieurwesen*, Aachen, 2016 (forthcoming).
- [4] B. Pedretti, "Lunario dell'Architettura 4: l'interprete parassita", *Casabella*, 592, 1992, p.31.
- [5] T. Widdershoven quoted in Hans Ibelings, "Favorite Color", <http://www.metropolismag.com/May-2003/Favorite-Color> (2016, march 30<sup>th</sup>).
- [6] MVRDV, *KM3. Excursions on Capacities*, ACTAR, 2006, p.568
- [7] Cfr. F. Colonnese, "Concept Model in Digital Age. Oma's Operational and Semantic Practices", in ,
- [8] A. Yaneva, *Made by the Office for Metropolitan Architecture: An Ethnography of Design*, Rotterdam, 010 Publishers, pp. 66-67.
- [9] Yaneva, op.cit., p.96.
- [10] Yaneva, op.cit., p.60.
- [11] <http://www.mvrdv.nl/projects/didden> (2016, March 30th)
- [12] As part of the cycle "1 architecte, 1 batiment", the conference "Didden Village, Rotterdam, Pays Bas" by MVRDV's Winy Maas took place in the Pavilion de l'Arsenal, Paris in 2008, October 8<sup>th</sup>. Dossier de Press: [http://www.pavillon-arsenal.com/data/videos\\_1a6c/fiche/7624/pav\\_219\\_cp\\_d0fb9.pdf](http://www.pavillon-arsenal.com/data/videos_1a6c/fiche/7624/pav_219_cp_d0fb9.pdf). Video: <http://www.pavillon-arsenal.com/fr/conferences-debats/cycles-en-cours/1-architecte-1-batiment/9448-winy-maas-mvrdv.html> (2016, March 30th, transcriptions by the author).
- [13] The idea of montage is entirely modern and influenced as much by Fordism and Taylorism that the artistic experiences of collage and film editing. M. Stierli, "Mies Montage", *AA Files*, n. 61, 2010, pp. 54-73.
- [14] <http://archinect.com/news/article/129868963/urban-homesteading-done-right-look-at-this-hidden-rooftop-cottage-in-manchattan> (2016, March 30th)
- [15] Nick Zangwill, "Aesthetic/Sensory Dependence", *British Journal of Aesthetics*, n. 38, 1, 1998, p.71.
- [16] Y-A. Bois, "Klein's Relevance for Today", October, n. 119, 2007, pp. 75-93; Thomas McEvilley, "Yves Klein, Messenger of the Age of Space", *Artforum*, n. 20, 1982, pp. 38-51.
- [17] Marco Navarra, "3+3 Grafting", *Compasses. Architecture and design*, n.1, 2008, p.21.
- [18] W. Maas, quoted from his conference "Didden Village, Rotterdam, Pays Bas", Paris 2008, October 8<sup>th</sup> (transcription by the author).
- [19] Arnold Lobel, *The Great Blueness and other Predications*, New York, Harper & Row, 1968.
- [20] A.C. Smith & K. Schank Smith, "The architect as magician", *The Journal of Architecture*, n.16, 5, 2011, pp. 765-783.
- [21] V. Ugo, *I luoghi di Dedalo. Elementi teorici dell'architettura*, Bari, Dedalo, 1991.
- [22] W. Benjamin, *The Work of Art in the Age of Mechanical Reproduction*, New York, Schocken Books, 1968, pp. 217-251.
- [23] Navarra, op.cit., p. 21.
- [24] J. Utzon, "Platforms and Plateaus: ideas of a Danish architect", *Zodiac*, 10, 1962, pp.113-141.
- [25] L.B. Alberti, *De re aedificatoria. On the art of building in ten books*, translated by J. Rykwert, R. Tavernor, and N. Leach, Cambridge, Mass.: MIT Press, 1988, p.34.
- [26] M. Pastoureau, *Bleu. Histoire d'un couleur*, Paris, Édition du Seuil, 2000.
- [27] A. J. DiFuria, "Remembering the Eternal in 1553: Maerten van Heemskerck's Self-portrait before the Colosseum", in *Nederlands Kunsthistorisch Jaarboek*, n. 59, 2010, pp.90-109.
- [28] "Grand Paris 10. MVRDV avec ACS et AAF", <https://www.youtube.com/watch?v=Q2aUi-kgxTs> (2016, March 30th).

# Colour emotion of 15th and 16th centuries Ottoman Divan poetry

<sup>1</sup>Begüm Ulusoy, <sup>2</sup>Mehmet Kalpaklı

<sup>1</sup> Bilkent University, Faculty of Art, Design and Architecture, Department of Interior Architecture and Environmental Design, 06800, Bilkent, Ankara, Turkey,

<sup>2</sup> Bilkent University, Faculty of Economics, Administrative and Social Sciences, Department of History, 06800, Bilkent, Ankara, Turkey,

## 1. Introduction

Colour is a fundamental visual bond that constitutes emotional, semantic, sensorial, and physical relations between people and their environment. Each individual, who has normal visual ability, perceives colours and define their environments with them. According to Wastiels, Schifferstein, Heylighen, and Wouters, the visual sense dominates one's overall perception [1] and vision affects decision making process at the time of buying more than other senses [2]. In addition, things which people see dominate their perception more than texts they read. As a well-known example, Stroop effect that proves colours might cause misreading of the words [3]. In everyday life, colours lead us to understand temperature of water, traffic lights, etc. and affect our perception and behaviours. These effects of colours are either conscious as traffic light or unconscious. For instance, brands' colours are consciously designed according to their meaning and emotions to affect the unconscious mind of the consumers, such as black is associated with expensiveness and power, blue for dependence and trust, red for high quality and love etc. [4]. An unconscious effects of colours can manipulate our choices during shopping, perception of interiors, understanding a lecture, etc.

Effects of colours on people and their environments are based evolutionary and cultural causes and roots. Colours and their meanings constitute with culture and are learned at childhood [5]. Therefore, a colour emotion in a culture does not resemble with another culture one-to-one and each colour emotion has clues about the culture it appears. As culture constitutes and is constituted by elements of its environment, it affects meanings and emotions of colours and these meanings and emotions affect the culture as well. Colour and culture relationship is not only what people see but also which meaning and emotions they associate in their minds. With evolutionary process people see the same colours but meanings and emotions of these colours in people's mind vary by culture. This diversity is visible with artworks. To identify relationship between colour and culture visually, artworks such as paintings, sculpture etc. might be explored. To investigate the same relationship semantically literature and language are utilized (see Fig. 1). Consequently, meanings and emotions of colours could be found from literature. In the case of Ottoman culture these notions could be probed in Ottoman Divan Literature. According to Geçgel, Ottoman Literature, which composed the contemporary Turkish Literature in the context of poetries, is poem oriented literature [6]. Other literary genres such as novel, story, short story etc., were rare, and were produced at the late era of the Empire with the effects of Western culture. In addition, the folktales were produced as oral literature and were not recorded until the last era of the Empire as well [7], however, poetries were recorded as Divans. Even Ottoman culture did not have diversity of prose genres; its diversity of poetry is so complicated and generous; The

Ottoman Literature is a poetry literature. Therefore, these poetries demonstrate the meanings and emotions of colours in their culture and, in this study, poetry is the main point in order to probe these meanings and emotions. The study findings are expected to be beneficial for authors, poets, designers, literature and Ottoman history researchers and might be used in cultural history of emotions, art and psychology studies.

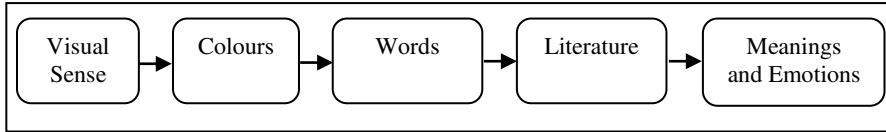

Fig. 1 - Association Scheme

## 2. Ottoman Divan literature

People associated emotions with different colours in different cultures and use different words for this process [8]. Each language has more than one colour; however, sophisticated languages require more [9]. To explore colour emotions, in this study, the researchers used 15th and 16th centuries Ottoman Literature, which had more cultural diversity than other centuries of the Empire. These two centuries were the richest era of the Empire not only for architecture and construction but also literature and poetry [10]. Each poet and their Divans were examined by themselves, however their collective features were also presented as well. For each colour, Ottoman Divan Literature has more than one word, for instance, black appears at the Divans as ‘siyah’, ‘kara’, ‘sevad’ and ‘esvad’. To identify these complicated list of colours through Divan Literature, the researcher investigated two fundamental poets’ Divans and define mostly used colours with their all possible names (see Tab. 1).

15. – 16. Centuries Ottoman Literature	
<b>Colour</b>	Renk, Levn, Elvân, Reng, Rengin,
<b>White</b>	Beyâz, Beyaz, Ebyâz, Ak, Ag, Ağ, Ağ, Sefid, Beyzâ, Bembeyaz
<b>Black</b>	Zulmânî, Qara, Qabqara, Kapkara, Kara, Siyah, Leyli, Kûfûî
<b>Red</b>	Kırmızı, Qırmızî, Al, Lâl, Kızıl, Ahmer, Qızıl, Ala, Lâle, Humret, Hamrâ, Erguvân, Ergavân, Gülgûn, Kıpızıl, Ruhsâr, Lâle-ruhsâr, Kıpırmızı, Aşfer, Şafak-reng, Ala
<b>Green</b>	Yeşil, Yaşıl, Ahdar, Ahzar, Hadrâ, Neffî, Sebz, Zebercedî, Gök
<b>Yellow</b>	Asfer, Safra, Zerd, Sarı, Saru
<b>Blue</b>	Mînâ, Mavi, Gömgök, Masmavi, Mât, Kebûd, Fîrûzefâm, Âbî, Âsmânî, Âbgûn, Erzak, Gök
<b>Purple</b>	Benefşî, Mür, Mor, Mosmor
<b>Orange</b>	Nârancî, Turuncu, Tutuncî, Narencî
<b>Pink</b>	Pembe, Gülgûn, Gülreng, Gül-renk, Penbe
<b>Brown</b>	Haki, Fındiki, Ela, Gahvani, Kahverengi, Ala
<b>Grey</b>	Gri, Boz, Kir, Kirgîl, Kuba, Çubar, Çıbar
<b>Navy Blue</b>	Laciverd, Lâciverdî, Lâciverdî, Lâciverd, Lâciverd

Tab. 1 - Word groups which define each colours in Ottoman Divan literature.

In the context of Ottoman Divan Literature (poetries), there are several studies which concentrate on a Divan of one poet. Eren investigated Baki’s Divan for the colour of ‘red’ [11] whereas Güfta elicited ‘black’ for same poet [12]. Kaplan studied ‘red’, ‘green’ and ‘black’ for Esrar Dede’s Divan [13]. Öztürk explored

'red', 'black', 'white', 'green' and 'yellow' for Fuzuli's Divan [14]. Another study investigated the colours which are associated with the mourning in classical Turkish poetry, and conclude that 'black' dominate the concept [15]. There is only one study which investigated 16 Divans for four centuries of the Empire (between 15. and 19. centuries) with 8 colours [16]. Although, the study concluded that 'red' is dominant colour of these Divans, number of investigated Divans for 4 centuries could not reveal profound presentation. In this study, 15 Divans are investigated for two centuries of Ottoman Divan Literature, as an initial finding, and the study is going to be. According to these initial results, approximately 100 Divans will be investigated as a future study.

### **3. Colour emotions**

Colours are related with meanings and emotions and colour emotions are not natural but cultural notions thus they have cultural reasons and relations. The previous study revealed that colour symbolism is notion of people for centuries and are affected by cultural background; for instance, British people prefer green apples, whereas Americans prefer red apples [9]. This preference of apple colour is independent from physical features of apple except its colour. As preference, colour emotions are cultural notions: for instance, White symbolizes purity in Western culture, but mourning in India [17]. According to Helvacioğlu colour emotion is "the evaluation of emotional responses of colour" [18], that are defined as feelings which are evoked by single colours or colour combinations [19]. Pile indicated that some colour emotions are universal and intuitive [20]; however, many others are more specific in a particular time and place. For example, people tend to relate red with fire, sun, blood, etc. so they associate red colour with similar emotions [9]. Even Palaeolithic art pieces have black, white and red constantly [21]. Deutscher stated that black, white and red are three basic colour terms that appear firstly on each language [22]. However, red might arouse sexy or danger feeling in different situations. Colour emotions have been studied with different researchers and Helvacioğlu prepared a list of emotions for colours, which was used for comparison by the current study (see Fig. 2) [18].

Walch and Hope presented the colour palettes of Turkey's Iznik tiles and Kilims of Anatolia [23]. The aim of this study is to demonstrate similar kind of colour palette with their meanings and emotions for the Ottoman Literature. For this aim, 15 Divans were investigated with Nvivo and its results were analysed by the researchers. Numeric data, which is quantitative data of the study, solely represents how many times these colour terms are mentioned in the selected Divans (see Tab. 2 and Tab. 3). Meaning and emotions, as a qualitative data, which are related to the colour, are defined by the researches in the light of aforementioned colour emotions list, their context in the Divan they appeared and the literature review.

COLOUR	EMOTION	
	<i>Positive emotions</i>	<i>Negative emotions</i>
<b>CHROMATIC COLOURS</b>		
<b>RED</b>	happiness, surprise, energetic, powerfulness, enjoyment, passionate	sadness, anger, fear
<b>PINK</b>	enjoyment, cheerfulness, warmth, feminineness	
<b>GREEN</b>	happiness, calmness, peacefulness, hopefulfulness, relaxation, comfort, modernism	aversion, boredom, fearfulness, anxiety, sadness, annoyance, mystery, neutral, non-emotional
<b>BLUE</b>	happiness, surprise, calmness, peacefulness, relaxation, modernism, harmony, serenity	sadness, fear, dull, cold
<b>YELLOW</b>	happiness, cheerfulness, excitement, surprise, enjoyment, warmth, dynamism, energetic	anger, sadness
<b>PURPLE</b>	creativity, fun, creativity, excitement	
<b>NEUTRALS</b>		
<b>BLACK</b>	powerfulness	sadness, anger, fear, boredom, aversion
<b>WHITE</b>	surprise	sadness, anger, boredom, fear
<b>GRAY</b>	-	sadness, anger, boredom, un- emotive

Fig. 2 - Emotional Associations of Colours [17]

## 4. 4. Findings and discussion

### 4.1. Numeric data

Divans	Colour	White	Black	Red	Green	Yellow	Blue
Ahmedi Divanı	109	3	47	57	34	21	30
Baki Divanı	40	11	12	67	11	23	7
Behiştî Divanı	37	10	10	5	5	13	0
Celîlî Divanı	34	8	14	9	12	2	1
Edhemi Divanı	15	6	7	7	6	8	0
Fuzulî Divanı	12	1	9	7	9	3	0
Hayretî Divanı	7	16	55	23	7	1	1
Hecrî Divanı	4	5	43	36	3	4	0
Lealî Divanı	8	1	5	21	7	2	0
Mesihî Divanı	6	23	34	28	9	8	2
Mihri Hatun Divanı	12	15	21	7	5	0	0
Nihani Divanı	4	6	18	5	3	5	0
Rahimî Divanı	11	8	27	25	5	10	0
Yahya Bey Divanı	16	48	93	40	31	3	4
Zatî Divanı	5	10	34	49	8	7	4
<b>Total</b>	<b>320</b>	<b>171</b>	<b>429</b>	<b>386</b>	<b>155</b>	<b>110</b>	<b>49</b>

Tab. 2 - Numeric Data (for Colour, White, Black, Red, Green, Yellow, Blue colour terms)

Divans	Purple	Orange	Pink	Brown	Grey	Navy Blue
Ahmedi Divanı	0	0	0	2	0	0
Baki Divanı	0	0	6	0	1	0
Behiştî Divanı	0	0	3	0	0	3
Celili Divanı	4	0	0	4	0	0
Edhemi Divanı	0	0	0	0	0	0
Fuzuli Divanı	0	0	0	2	0	1
Hayreti Divanı	0	0	9	3	0	0
Hecri Divanı	0	1	1	0	0	0
Leali Divanı	2	0	0	1	0	0
Mesihî Divanı	0	0	4	0	0	1
Mihri Hatun Divanı	0	0	0	1	0	0
Nihani Divanı	0	0	0	3	0	0
Rahimi Divanı	0	0	1	0	0	0
Yahya Bey Divanı	0	0	0	3	3	1
Zatî Divanı	1	0	7	4	0	2
<b>Total</b>	<b>7</b>	<b>1</b>	<b>31</b>	<b>23</b>	<b>4</b>	<b>8</b>

Tab. 3 - Numeric Data (for Purple, Orange, Pink, Brown, Grey, and Navy Blues colour terms)

Black, Red, Colour, White, Green, Yellow, Blue, Pink, Brown, Navy Blue, Purple, Grey, and Orange are mostly mentioned colour terms for the concept respectively. Grey, Purple and Orange are detected less than any of other colours. However, Black, Red, Colour, White and Green are mentioned by each poet. In contrast with the previous study of Uğur [16], Red is not the dominant colour for these Divans (see Tab. 2 and Tab. 3), however, Black is the most frequently preferred colour.

#### 4.2. Meanings and emotions

There are two categories, which are defined by colours, for meanings and emotions: physical and figurative features. Physical features describe literal features of the concepts such as physical characteristics of people, animals, objects, etc. and represent positive or negative meanings and emotions with them. Figurative features define metaphorical associations with meanings and emotions. Black defines physical features of loved one such as hair, eye, face etc. or literally colour of some objects and animals such as rocks, ash, mountain, horse etc. To define a beloved or an animal, Black is mentioned by positive meanings and emotions, however, to identify a face of rival or an ash, it represents negative ones. Its figurative features are more complicated than physical features. Black times, soil, clothes, clouds, religion, heart, water/sea, love, news, anxiety, mind, destiny, soul have negative associations in the context of different situations. Its meanings are pain, misfortune, ignorance, death, mourning, negative mood, irreligious, illiteracy, and unhappiness. These results reveals that, similar to Western cultures, Ottoman society related Black to mourning as stated by the previous researcher [15]. When Black colour defines physical features it may have positive associations accordingly to context whereas its figurative features are only associated with negative meanings and emotions, as suggested by previous study [15]. Colour, as main task of the study, is constantly related with positive meanings and emotions such as flowers, wine, morning, hair, etc. Also the poets used verb of ‘encolour’ which means making colourful and joyful someone or something and associated with positive features.

Red has positive associations for both physical and figurative features except its relation with blood, fire, and face. It symbolises flowers, beauty, nature, wine, fabric, parrot, pomegranate, which mean positive meanings and emotions such as love, joy, satisfaction, freshness, wealthy. However, it is utilised to define danger, pain, and sadness with its association with fire and blood. Only, Celili and Zati associated red face with shyness or shame. Green is always associated with positive meanings. It defines some physical elements such as parrot, flowers, clothes, grass, etc.; however, it also means spring, abundance, religion (with the colour of minaret). Yellow, which has both positive and negative associations, appear with physical features as fabric and flowers, and figurative features as beauty (with red) and illness/mood as skin colour. White is more complicated about its figurative features such as wise, death and love, which are both negative and positive associations; however, it defines physical characteristics of snow, flowers, marble, cloud, etc. with positive associations. Pink, Brown, Blue, Grey, Purple, and Orange define solely physical features. For example, Pink for flowers, skin and clothes; Brown for eye, hair, clothes, Grey for especially animals such as hawk and horse, and Purple for flowers. Orange is mentioned by only one time as a colour of wedding dress. Previous research suggested that Black, White, Red, Green, and Yellow have both positive and negative associations for emotions [17]. This study's findings prove that, except Green, all other colours (Black, White, Red, and Yellow) have both positive and negative emotions. Black, White, Red, and Yellow are used as to define soul which means these colours are associated with specific state of mind: Black and Yellow for negative conditions such as mourning, depression, etc. and Red and White for positive conditions such as happiness, joy, blessed, etc. These results show that for Ottoman Divan Literature; Red, Yellow and White are mostly related to positive emotions, however, Black is associated with only negative ones and Green is always associated with only positive emotions.

## 5. Conclusion

Ottoman Divan Literature is colourful literature which has not been investigated by colour emotions. Black, White, Red, Green and Yellow are important elements of the poetry with their meanings and emotions which appear with both physical features and figurative features. However, other colours have not got same magnitude, their existences prove that the Ottoman Divan Literature has diversity in the context of colour. As a result, this colourful literature proves people of its era associated Green and Colour with positive meanings and emotions; however, Black, White, Red, and Yellow have both, whereas Red had more positive meanings and emotions than Yellow and White. Black, as a colour of mourning and negative emotions, is only related to positive meanings in order to define beauty of beloved, animals, or objects such as black eyes, black horse, etc. These findings demonstrated that Ottoman Divan literature needs further investigation thus elaborated results might present different emotions in the context of colours.

## Bibliografia

- [1] L. Wastiels, H.N.J. Schifferstein, A. Heylighen, I. Wouters, "Red or rough, what makes materials warmer?", *Material and Design*, 42, pp. 441-49, 2012.



- [2] A. Fenko, H.N.J. Schifferstein, P. Hekkert, "Looking hot or feeling hot: what determines the product experience of warmth?", *Material and Design*, 31, pp. 1325–31, 2010.
- [3] Y. Yüksel, "Stroop Testi ve Etkisi", Retrieved from <http://yunus.hacettepe.edu.tr/~yyuksel/v1/stroop/>, 20 May 2013; 17:32.
- [4] E. Seimiene, E. Kamarauskaite, "Effects of Brand Elements on Brand Personality Perception", *Procedia-Socail and Behavioral Sciences*, 156, pp. 429-434, 2014.
- [5] E.Ş. Ekici, C. Yener, C., N. Camgöz, N. "Colour Naming", *Optics & Laser Technology*, 38, pp. 466-485, 2006.
- [6] H. Geçgel, "Yeni Bir Nesir Dili Kurulmasında Ömer Seyfettin'in Görüş ve Önerileri", *İnsan ve Toplum Bilimleri Araştırma Dergisi*, 1 (2), pp. 118-130, 2012.
- [7] Y. Özay, "Metinlerarasılık ve Türk Halk Hikâyelerinde Ana-metinsel Dönüşümler", *Milli Folklor*, 21 (83), pp. 6-18, 2009.
- [8] T. Nakamura, O.P.N. Sakolnakorn, A. Hansuebsai P., Pungrassamee, T. Sato, (2004). "Emotion induced from colour and its language expression", AIC- Colour and Paints, Interim Meeting of the International Colour Association: Proceedings of an international conference held at the Convention Centre of the Pontificia Universidade Catolica de Rio Grande do Sul, 3-5 November, pp. 328-332, Porto Alegre: Brazil, 2004.
- [9] K. Fehrman, C. Fehrman, "Colour: The secret influence", New Jersey:Prentice-Hall, 2000.
- [10] A. Niyazioğlu, "How to Read an Ottoman Poet's Dream? Friends, Patrons and the Execution of Figānī (d. 938/1532)" *Middle Eastern Literatures*, 2013 Vol. 16, No. 1, pp. 48–59, 2013.
- [11] A. Eren, "Bâkî Divanı'nda Siyah Kırmızı Renk", *A.Ü. Türkiyat Araştırmaları Enstitüsü Dergisi*; 37, pp. 31-68, 2008.
- [12] H. Güfta, "Bâkî Divanı'nda Siyah Renkli Unsurlar", *Turkish Studies*. Volume 4/8, pp. 1314-1373, 2009.
- [13] M. Kaplan, "Esrar Dede Divanında Renkler", *Electronic Turkish Studies*, 8.1, 2013.
- [14] S. Öztürk, "Fuzuli'nin Türkçe Divan'ında Renkler", Master Thesis, Ordu: Ordu University, 2011.
- [15] M.E. Harmancı, "Klasik Türk Şiirinde Matemin Rengi", *Folklor/Edebiyat*, cilt:13, Sayı: 50 pp. 129-138, 2007.
- [16] E.Y. Uğur, "Klasik Türk Şiiri'nde Renkler", Master Thesis, Kırıkkale: Kırıkkale University, 2009.
- [17] L. Holtzschue, *Understanding colour: An introduction for designers*, USA: Wiley; 2006.
- [18] E. Helvacıoğlu, "Colour-Emotion Associations in Interior Spaces", Ph.D. Dissertation, Ankara: Bilkent University, 2011.
- [19] L. Ou, M.R. Luo, A. Woodcock, A. Wright, "A study of colour emotion and colour preference. Part I: Colour emotions for single colours", *Color Research & Application*; 29: 3: pp. 232-240, 2004.
- [20] J. Pile, "Colour in interior design", New York: McGraw-Hill, 1997.
- [21] S. Petru, "Red, black, or white?: The dawn of colour symbolism", *Documenta Praehistorica*, 33, pp. 203-208, 2006.
- [22] G. Deutscher, "Dilin Aynasından Kelimeler Dünyamızı Nasıl Renklendirir?", (C. Yardımcı, Trans.). İstanbul, Turkey: Metis 2013 (Original work published 2010).
- [23] M. Walch, A. Hope "Living Colours: The definitive guide to colour palettes through the ages", San Francisco, CA, USA: Chronicle Books, 1995.



# Color and history in designing containers inspired by “KolahFarangi” Building of “Mohtasham” Garden in Rasht city

Laleh akbar

MA. Industrial Design, University of Tehran, Laleh\_akbar.iran@yahoo.com

## Abstract

Life is full of colors painted the different chapters of history during the past years and centuries. Old cities which have been the cradle of civilizations and culture have a rich and colorful identity. Rasht city as capital of Gilan province in North of Iran had a specific importance in past decades due to neighborhood with Anzali as the gate of Europe and by the time being it is considered as one of the cities with various potentials. Registration by UNESCO among the creative cities of the world as the food creativity city, it a great opportunity to design newer containers based on its various and colorful foods, designs with local identities which may help us a great deal in offering new brands. Mohtasham garden is one of the old and big gardens of Iran which dates back to Naseraddin Shah Ghajar ruling period. The design of the garden and its paths and preparation of primary shrubs are among the memorable times recorded in the history of this city. Famous “KolahFarangi” building in “Mohtasham” garden is a fabulous building with its unique architecture and due to its specifications is one of the main touristic attractions in Rasht city. Designing local containers inspired by this building is a reflection of colors and chapters of history of this city and its people. These containers are designed in 5 piece sets to remind the 5 angles of the building architecture with the same colors used in the building design.

The objective of this study is to recognize applied historical and cultural elements and the colors used in the building and their reflection in design of containers. To achieve such an objective, an applied study was done in the field of food culture of Gilan in various areas including study of various local containers and their applications, interview with authorities and container manufacturers, food producers and suppliers, study of traditional and weekly markets in the area, filling questionnaire by the target groups and operators and studying role of color in all above items. The results of this study will be presented in 2 practical and theory sections.

**Key words:** Color, “Mohtasham” garden in Rasht city, “KolahFarangi” building, container design

## 1. Introduction

Rasht, creative city of food in the UNESCO...! To globalize, every single one of those words certainly is more than their literal meanings. By wide variety of food of soul and body, a nutrition topic has much broader range of food & eating and our daily fullness.

Although, food in Mazloo's Pyramid classification, includes in human life's early levels & basic needs, but over passing the different layers of life & get the higher lever of the pyramid and to the top of the creativity & self-fulfilment, human life will be revived again and would have very different quality toward the past. By coordinating basic need (food) with high levels of growth (which is creativity and self-fulfilment), Rasht is deserved to register its name in UNESCO. Understanding the quality of life in Gilan is perceived very well in different way of living, customs, hospitality and so on as well as diversity of delicious foods of this region. This diversity of foods is sign of intelligence, insight of people who is life lover & accepts the life through the knowledge of different taste. And all originate from ancient history & geography which caused to be under the observation of many researchers & scholars around the world.

However, in mentioned powerful sectors of this culture, the empty space of creative & effective methods of supply can clearly be seen. Since, every culture (according to its characteristics) gives rise to produce indigenous products, these products, in turn, cause to form the modern culture in society. Here, (based on much more knowledge of this culture & deep understanding of intercultural communications) it should be focused on the role of indigenous product supply in domestic & international markets. (According to social nature of Rasht & Gilan Province), Success in branding requires precise methodology based on cultural values, identity & their association [1].

By looking at the food diversity over 170 types of food (only in northern part of Iran) and just limited number of plates- as indigenous dishes- the more versatile & valuable consequences of historical and valuable heritage of this city should be presented to world memories by means of dishes designs (which is inspired by pavilion building of Rasth Mohtasham Garden). The idea for high rankings of Iran history (which were founder of this pavilion & garden) caused pleasant memories to be remained for the people from Rasht and other people who traveled to this city. -in addition to public memories- prestige and dignity of memorial memories for this garden can be seen in works of artists, poets, musicians, painters, photographers, etc.

**Color:**  
From long time ago, the colors always are surrounded the human life and is under its influence. We are recently able to produce color and use them. In the last hundred years, many changes have been occurred in this area; first the color has easily obtained from Aniline compound, later through the indigenous-tar derivatives & Metallic Oxides. Today, every man-made object has color. Thousands color- any color which will be imaginable- were produced, and almost for any purpose, any

color is provided. In addition to sky-blue color, sunset red & tree's green color & all the natural colors are available, the man-made objects, kept us enthralled and enticed constantly [2].

The color forms the life because the world without color seems to us like dead. Colors are ethereal examples & the product of the main color; without color & its counterpart, they are dark. As the flame emits lights, light creates the color as well. The color likens the child of light and the light is also their mothers. The light- basic phenomenon of universe- manifest us the world soul & spirit through the colors. Nothing more than the landscape for colored halo of sun in the sky influences on human soul. Lightening frightens us. But, the color of rainbow & the light of first dawn eases & mitigate our soul. The rainbow is considered as sign of peace. Word & its sound, form & its color are like container of superior essence which we can't clearly understand their existence. As the sound causes the word to be colored & shined, the color animates the life & soul as well. Original essence of color is the imaginative & variable shapes of sound waves, and the color became sound. When the thought, understanding and the standardization is applied to color, the spell will be broken and nothing more than its bulk remained. Emotional state of people (in that epoch of history) can be seen in the colored building of the past [3].

## **2. Mohtasham garden of Rasht**

Rasht in Guilan Province center which is located in the northern part of Iran is known for silver rain's city.

This city- except Manjil & Roodbar that are midway of Guilan- is the most important city which is established at the entrance of this province. This geographical location of Rasht is assumed high score for it. Its climate is Caspian temperate and had hot & humid summers as well as mild winters. Its original inhabitants are made up Gilaks. As mentioned in historical sources, this city likely comes to existence before Islam in Sassanids. Rasht was called Dar al Amare (Dar olMarz) in the past.

In the past, this city was considered the only communicational & commercial way through the Anzali Port to the Europe. From the Shah Abbas II till end of Qajar reign, Rasht was the Major commercial center. Also to buy the silk, caravans came to stop in Rasht and through it, their goods have been forwarded to Mediterranean Ports. Residents of its cities are mainly engaged in Service-, commercial & industrial jobs. In addition, rice cultivation is the major activities of the villagers in this region. In agriculture, this region is the most susceptible areas of province & whole country. According to the geographical, economical, social, cultural & political-administerial conditions, Rasht contains significant characteristics. From the viewpoint of geographical situation (being located in central plains & its large size, fertility of soil, the most important region to produce and cultivate the rice) & its communicative situation (being situated on the way of Tehran, Qazvin, Anzali, Astar (on one hand) & the main road of Guilan (on the other hand), administrative-political situation (being located in Rasht as the center of Guilan Province) and from viewpoint of economic expansion & industrial cities' extension & industrial plants' building & subsequently increasing commercial-agricultural activities, this city is important. From the view point of anthropology, this city  
Its social & cultural examination is necessary [4].

of the most important tourism & historic attraction in Rasht are its pavilion, city hall, post office building, Rasht museum, old houses, National Library of Rasht, Armenian Church, Latinn,GuilanRual Heritage Meuseum, House of Tourism, Mohtasham garden and etc...



Image 1- Map of Rasht.Source: :www.touristhaa.ir

## 2.1 Mohtasham Garden

Mohtasham Garden of Rasht is one of the largest & oldest gardens in Iran. Its history of construction goes back to several generations ago. Primitive owner of this was Akbar Khan BiglarBeigi who was known this garden as BeiglarBeigi under his title. He -who was first level of wealthy landowners during the age of Naseri- was the head of following dynasty families: Akbar, Naeemi Akbar, Khan Akbar, Omeshei, Naeemi & Amoo. In his own time, he has been the source of many services including: assistance & aid in construction of Rasht & suburbs roads as well as charge of most Iran's customs office. At the time of Ghasem Khan Vali reign, BeiglarBeigi was paid more attention & respect and appointed as Rasht Sheriffdom.

Since Akbar Khan has no son, he liked Fathollah Akbar- his nephew (General Mansoor; Major General Azam Rashti- Prime Minister during Qajar age of Ahmad Shah) as his own son. At the time, Fatollah Khan which was qualified, competent & trustworthy young man- could carry out a series of affairs by his own competent hands & continued his own uncle's way. Through his knowledge & his own social relations, he could be worthy successor to his uncle by all account.

He engaged in Mohtasham garden's current land (which was known as Naserieh for Naseredin Shah's stopping and temporary staying on his way to Europe) to construct big garden. Today, it is the largest & oldest Garden in Iran. By suitable skill for attention, Fatollah Khan designed the garden map with the aid of a Russian engineer & drew it up on the paper. By his observation, planting trees begins in the streets which is seen on the map. Let it not remain unsaid that numerous individuals were appointed to produce the initial seedling in Gilan's villages for a successive time. Seedling was obtained very difficult. According to customs & beliefs of that time, under every tree, a coin was placed for blessing in planting time. Then, Garden was built and indigenous called it Green Pavilion (due to the green glazed pottery and some named it Pavilion building. The garden was surrounded by

wooden fence too. Evidently, the first night that garden constructing is finished, Akbar Khan-who was the host of time ruler & a handful of city respected people-had heart attack & passed away after the party and couldn't see the next day. During his lifetime, Akbar Khan Beigi was interested but after his death, garden ownership was belonged to his nephew (according to Fath Allah Akbar's efforts in constructing the garden), but MohtashamAlmol (Trustworthy General- the post & telegraph's post in Qajar's time) was encountered by Sadegh Khan Akbar- cousin husband's interesting, subsequently, Fathollah Khan insisted that the garden would be place on his daughter's divisions. Since Sadegh Khan gave him the title MohtashamAlMolk at the time, he converted its garden name to Mohtasham-his name. Later, this garden's heirs transferred it to the government in return for taxes. And now, it's in the possession of Rasht Municipality [5].

Factors such as-thousand trees( generating the planted with trees streets) of this park, accuracy in layout of streets & observance of trees distance, accuracy in landscaping & enjoying the scientific methods in this park establishment caused to above-mentioned location became the most beautiful & largest parks in Iran since its establishment until now (late 13<sup>th</sup> century (hejira)). in terms of applying the scientific principles & methods, establishment of public gardens is registerable in Iran national works's list (at the end of 13<sup>th</sup> century) [6].

### **3. "KolahFarangi" building**

KolahFarangi" building (located in the south side of Mohtasham Garden), by Gohar Rood & clay-covering roof (compatible with green trees of Mohtasham garden) is made up 3 storey & was built on special country form in two octagon & square shapes; they were located beside each other. In total, it has given the beauty to the building. On its first and second floor, each contains 2 rooms and on the third floor, a room is built in the form of simple pergola.

The materials (used in building) are made of brick & wood and its roof as ridgy & its cover is devised of barrel ceramics. Under it, there are ceramics; their functions are: heat & cold insulation of building and keeping the ceramics safe. On the first floor, Surroundings of it is like veranda & on the second floor, is built as wooden balcony and keeps 68 pillars balcony of building roof. Also its range is made of wooden valves and has double covers. To prevent from rain and snow downpour inside the building, it built long [7].



Image 2- Pavilion building for Mohtasham Garden in Rasht

Source: news.irib.ir



Image 3- Mohtasham Garden in Rasht.  
Source:www.mahstan.ir

#### 4. Dishes' design

it means the location & place of inserting dishes. And whatever designed to this end is called dishes' design. Dishes consist of different kinds including: kitchen utensils (including all types of pots, frying pans, percolator, baking trays & so on; they produce to store, prepare & cook the foods in different kinds.)

Entertaining dishes (it is wide range which includes: all types of plates, bowls, platter, saltshaker, pepperpots, sugar basin as well as disposable dishes; it is used in situation that it is not possible to wash the dishes conveniently). [8]

Laboratory glassware (these are produced to use in laboratory in different shapes & capacities) & other dishes...

By means of nature elements & historical & indigenous architecture for Pavilion building in Rasht, factors such as:

- 1) the importance of mentioned contents in current study- as historic background of city (that even has gained global achievements);
- 2) love & responsibility in the role of a industrial designer;
- 3) interesting in a branch of designing as dishes' designer;
- 4) also the writer's relation as family or one of the remaining members of family & original owner of Mohtasham garden, caused the dishes products (in order to use the indigenous foods) designed.

The dishes are in the forms of such as: cups, saucer, pads, plates & tureen and all kinds of fruit & sweet dishes and so on.... Selected colors are green, brown & golden. Green selected color inspired by clump of garden trees which is enclosed the in-outside of garden. Green pottery -which has been covered the pavilion's roof in the past- has special places in historical memory of this city.

Its brown color inspired by the trunk of trees that in addition, covered the garden, garden surroundings were enclosed by wooden fence in the past. Its material was that kind which has been used in pavilion construction. All sides of these dishes are octagon & square modes which influenced by sides of pavilion for Mohtasham Garden in Rasht. Because of three storeys being in this pavilion, octagonal sides of



dishes were the (in brown color) 2 Cm distance from perimeter & second line in dish, pad & saucer designs as well. At the end of all dishes, there are symbol of golden coin in it to remind the coins which were put under the trees when planting.



Image 4- Coin for Ahmad Shah of Qajar Era.  
Source: www.sekeha.com

Among the mentioned dishes service in each design, there is single dish with sky-blue (color) background. This designing is a symbol of city sky which is the spectator of this garden & old building in it. The colors used in these dishes are: blue, blue-green, brown & golden. It seems that the color & pavilion and garden are reflected in sky. All designed dishes made of clay & were suggestive of traditional & indigenous main dishes in Rasht and Gilan province.

In this product colors are used as a symbol and symbolic study of culture. Since as the identity of a product, color may have a specific meaning and also, since colored shaped may take the viewer to an imaginary world and that is why visual attractiveness of a product may be reinforced by implying special atmosphere, location and situation. For example, using colors like sky blue, azure and grass green is a symbol of sea and green landscape. The matter of color in industrial design is another field of creativity and the designer may decide in various aspects like selecting color suitable for application of product, color symbolism and other areas.[9]

This study is an effort to introduce & remind the old times that amazing memories & stories (in the heart of its history) are housed elsewhere. Yes, to seek an excuse of using the indigenous dishes inspired by Rasht pavilion building, the color, water & food history for this creative city should be savoured now.

## Bibliografia

- [1] Akbar-Laleh- 2015- Rasht- the creative city of food in UNESCO- Dadgar Journal- 8<sup>th</sup> year- No.37, Rasht)
- [2] Lusher, Max, 2007, Tehran, Dorsa, Color Psychology
- [3] Ethan, Youhaness, 1999, Tehran, Yesvali, Color art.
- [4] www.guilan.ac.ir
- [5] Akbar, Manoocher, 2015-memory maker'trees-Dadgar Magazine-8<sup>th</sup> year- No.37-Rasht.
- [6] , [7] www.rasht.ir
- [8] Hoteldari.com
- [9] Borja,de., Mozta, B., Design and Management, Les editions d'Organisation, Paris, 1990.



# Colour of residential architecture of classicism and neoclassicism in Russia

<sup>1</sup>Mariya Komarova

<sup>1</sup> Dep. Architecture and Design, Politecnico di Torino, mariya.komarova@polito.it

## 1. Colour evolution in Russian residential architecture

The Russian residential architecture has remained wooden for a long time. The colour of an ordinary building of pre-Petrine Russian cities determined by the fact that the street was imaged purely functional and served only as a passage. Manor, "interior" way of developing prevailed in the cities. Houses were situated within the plot of land, and fences were facing the street, so log towers and white-stone palace "disappeared" for the city [1].

Large centers of Kremlin and the Moscow monasteries polychromy and of other Russian cities of that time were not supported by the colour accompaniment of residential buildings, didn't develop in polychromy of streets and squares. The exceptions were the central part of the defensive fortifications, churches and a small number of stone palaces. The colour image of Russian residential architecture, which is dominated by wood, was associated not only with the colour restraint, but with expressive colour range of soft ochre-brown and gray-silver shades. Against this background, striped delicate wooden carvings and colourful patterns with natural ornaments made by folk artists, gave an appearance of festivity and hospitality to simple dwelling houses.

Colour, both in public as well as in residential architecture, determined by the characteristics of architectural styles after the urban planning reforms of Peter I. A combination of cobalt, blue or pistachio (general background) colours with white details, with a gilded and dark bronze decor are typical for Russian Baroque of the middle of the XVIII century. These colours are inherent in the palace architecture of St. Petersburg and its suburbs.

With decrees by the Senate of Catherine II from 1773 brick and stone became the basic building materials due to frequent fires of wooden buildings in the Russian cities. Residential homestead with a complex of household buildings on the mansion (stable, coach-house, woodshed and hayloft) became the major urban development unit from the period of 1780s. [3]. However, people continued to build wooden houses, but with a new decorative material - plaster, which served as a kind of camouflage and not "betrayed" the basic building material. During the reign of Catherine II in the Russian architecture due to the Italian masters the style of classicism arose, in which the cities around all the country built up for decades. Classicism developed its attitude towards colour and its range of colours, particularly active in early XIX century. Residential architecture acquired a new colour scheme. (Fig.1)

## 2. The artistic unity of Russian classicism

The Russian architectural palette of colours became regulated by special decrees in the era of Alexander I. The emperor has begun regulation of urban colourity from Moscow after the visit to the city in 1816. The decree was issued that the houses and

fences must be painted more delicate and with the best of light colours: *dikiy* (greyish, gray, and ash grey), *blanzheviy* (flesh-colour) (Fig.2) and pale yellow with green tint. Stone structures according to the decree could be whitewashed [6]. Special Commission for the country's development and building that was created by the emperor's decree gave the plans and facades for the construction of new and for the repair of burned houses. It also obliged the owners to paint houses on plaster with light colours only: light yellow, light green, light gray or white.

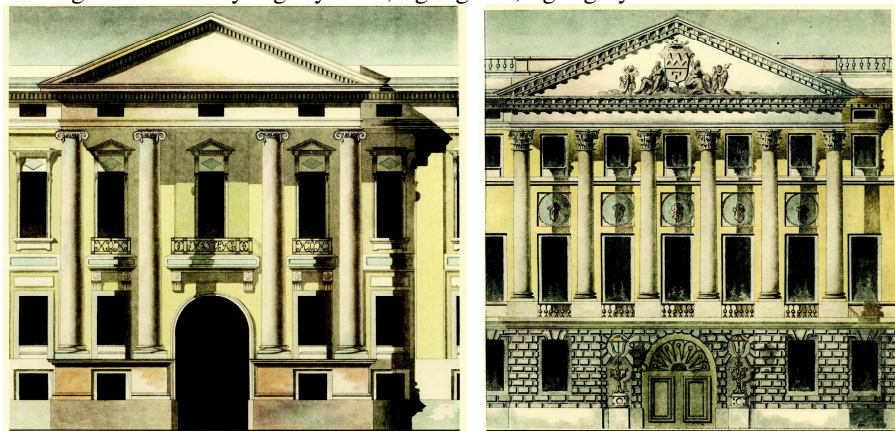

Fig. 1 - Prozorovsky House on Tverskaya Street is on the left (demolished in 1930). Demidov House on Gorokhovskiy Lane is on the right (from 1925 it is Ushinsky Scientific Pedagogical Library). Architect Matvey Kazakov, the end of the 18th century.

The following decree of December 13, 1817 strictly regulated the architecture colour of St. Petersburg. It was allowed to paint houses according to the following colours only: white, pale yellow, maize yellow, light gray, *dikiy* (silver gray), pale pink and Siberian (copper-green), but with a large admixture of white paint [7]. A special commission was engaged in the selection and control of the colours. Paint samples were sent for construction on special wooden plates, which can be considered a kind of prototype of modern colour chart. The police supervised the rules of painting.

With these decrees, all the houses in the central streets of Russian cities united in a single colour system. Tight colour regulation of a large number of the buildings played a great urban planning role: it helped to create colouristic unity of streets and squares, to form a complete colour environment of the city.

Soft pastel colours (with lots of white) - pale yellow, pale blue, pale pink, greenish, being legalized by decrees of the emperor were the predominant palette. Analyzing image colouristic Smolensk XVIII century, Z. Pastukhova notes that there was a dominant colour in the urban architecture, "colour scheme in the city of Smolensk was often subordinated to the main colour scheme: to Smolensk, Roslavl, Gzhatsk, Dorogobuzh, Porec - muted yellow and pale yellow. Motley inflorescence reigned only in Vyazma: white, yellow, and red" [4].

Two-colour art becomes the norm in the architecture of late classicism. This principle is organically linked with the compositional system. Two contrasting colours correspond to the combination of massive architectural elements and details with a large background planes of the walls. White columned portico, white relief

moldings - masks, garlands, friezes - clearly stand out on the surface of the warm, ochre-yellow walls, and these two primary colours enrich each other.



Fig. 2 - Khomyakov House. The facade along Kopyevsky Lane, architect Giuseppe Bova, 1823.

The project of restoration, reconstruction and technical equipment of the Bolshoi Theater complex of buildings, elaborated by ZAO «Kurortproject» and OOO «Restavrator-M», 2009-2011.

Two-tone facade is connected not only with the peculiarities of the composition, but also with the material - plastered brick and wood. Plaster serves as a carrier of independent plastic and colour characteristics of the architectural work. Through the development of architecture, finishing techniques and artistic crafts plastered wood itself became a new material with new properties. Painted plaster is an essential element among the architectural features and expressive means of Russian classicism. Aristocratic mansions and manor houses, having in the constructive manner wooden house, were designed in a new way. White columns, organizing a portico were created from simply logs, posed upright and sheathed with plywood, sometimes stretched over a canvas on which was deposited a layer of plaster. Basement rustication was composed of plaster planks; and "stone" surface of the walls got the opportunity thanks to the same plaster to be painted in intense colour. Classicism was the leading style in the architecture of the Russian Empire, at that time the construction of new towns has become an unprecedented scale. This served as a model for urban development also in the Soviet Union.

### **3. The main characteristics of the Soviet neoclassicism: classical details and colour.**

At the beginning of the 1930s. the impact of state sharply increased on all spheres of life of Soviet society. Neoclassicism in architecture became the predominant style of the Stalin era, lasted until the end of the 1950s. After the Second World War, Soviet cities were re-built, which included Minsk, Kalinin, Volgograd (former Stalingrad).

At the time the promotion of traditional values and the ideology of good citizenship received widespread, and that was the main criterion for strengthening the position of Stalin's neoclassicism.



Fig. 3 – Residential buildings of Soviet neoclassicism , 1940s.

This style also appealed not to the forms, but to the compositional principles of Russian architecture and its classical heritage. Soviet architects took a great interest in in-depth study of historical patterns, detailed imitation of decorative details, and reproduction of lush classical orders decoration. Antique order combined with stucco heraldic compositions was almost always used in the design of houses. In some cases attributes of the Imperial Empire, inspired by the French model (wreaths, shields, and spears) were also met [2].

As for the colour composition of facades, it also borrowed the colour palette of Russian classicism. Golden-white bicolour usually dominated in the range of pastel

colours. Since Russian classicism, it has become an integral feature of Russian cities, because it successfully made up for missing the warm shades of the northern nature, created a golden glow of the atmosphere, even on cloudy days (Fig.3).

Stalin's neoclassicism primarily pursued urbanistic targets, so in the spirit of the new style were built shops, railway stations, schools, factories and dwelling houses. Rebuilds entire streets and squares. Architects sought to create symmetric static buildings, completely abandoning any stylistic confusion.

#### 4. Colour transformation and reproduction of the historical colour atmosphere.



Fig. 4 - Chernyshev House, project by M.Kazakov. Now it is the building of the Moscow mayor's office.

With the help of colour it is possible to emphasize individual buildings among other structures of the architectural complex. A striking example of this is the building of the Moscow mayor's office, which is located on Tverskaya Street, 13. In 1782 the residential house was built by count Z. Chernyshev in the style of Russian classicism on the project of architect Matvey Kazakov. (Fig. 4) In 1790 the Treasury bought the building. The original facades were made in yellow and white. Since 1917 the building was under the jurisdiction of Moscow Soviet, it acquired intense colour (rich dark red), which became to emphasize it among the other buildings formed the

street and the area adjacent to the building. Even now the building of Moscow mayor's office plays a dominant role in the streets and squares composition. (Fig.4)

In the late 1940s, after the Second World War in the Soviet Union not only central but also peripheral, working-class districts of cities began to be built the new low-rise residential buildings which were popularly dubbed "the German". In reality, these homes were designed by Soviet architects in the style of Stalinist neoclassicism. These residential areas are particularly noteworthy, as examples of the colour reproduction of the atmosphere of the historic city center in a large residential area on the periphery. Colour themes of the past, typical of the period of dawn and rise of Russia after the victory in the War of 1812 were used in new areas of Soviet cities. This caused the residents a sense of belonging to the country's history, a sense of patriotism, was assessed positively, which further led the Soviet Union to the industrial and economic development.

## 5. Conclusions

The use of colour is a complex and multifaceted problem in architecture. The creation a colour environment, having a sign of wholeness and completeness, requires an integrated approach to the definition of objectives the colour use in architecture. A clear relationship of architects, builders and the state, allows us to solve a number of ethical, psychological, and economic problems. Examples of Russian classical and Soviet neoclassicism argue that strict regulation can promote active colour transformation of ancient cities and favorably affectes on the creation of unified colour environment of the new-built areas.

Architect using colour reveals the logic of three-dimensional structure, which is inseparable from the creation of psychophysiological human comfort . Colour is an important part of the architectural form. In appropriate combination the colours is a means of expressing the architectural structure content, its aesthetic merits.

Theoretical studies in the field of colour and the development of functional and aesthetic demands of architecture open up new horizons in the use of colour in architecture [5].

## Bibliografia

- [1] Efimov A. "Urban colourity", Moscow, Stroizdat, 1990
- [2] Grigoriev I., "Stalin's neoclassicism", 28 March 2015, <http://tartle.net/blog/189-stalinskiy-neoklassicism/>
- [3] Komarova M. "Architectural and landscape heritage of the Russian Imperial age (1763-1843) under the conditions of urban transformation": Drawing&City. Culture, art, science, information, Marotta, A., Novello, G. (Editors), pp. 647-650, Roma, Gangemi, 2015
- [4] Pastukhova Z., "Architectural monuments in Smolenschina", Politicheskaya informatsia, №13, p.26, 1980
- [5] Potokina T., "Concept of colour and its role in architecture", Ser. 7, Filosofiy № 1 (9), pp. 77-79, Vestnik Volgogradskiy State University, 2009
- [6] Speranskiy M., "Complete Collection of Laws of the Russian Empire. First Collection. Volume XXXIII. Years 1815-1816", St. Petersburg: Second section of the private chancellery of His Imperial Majesty, 1830
- [7] Speranskiy M., "Complete Collection of Laws of the Russian Empire. First Collection. Volume XXXIV. Years 1817", St. Petersburg: Second section of the private chancellery of His Imperial Majesty, 1830



# Sitting in a kitchen full of colours with Claude Monet and Carl Larsson

<sup>1</sup>Maria Ahlqvist-Juhlin, <sup>1</sup>Monica Moro,

<sup>1</sup>Department of Arts, Communication and Education, Luleå University of Technology (LTU), Maria.Juhlin@ltu.se, monikamoro@yahoo.it

## 1. Abstract

Maria Ahlqvist-Juhlin, researcher in Media and Graphic Design and Monica Moro, Colour and Design researcher carry out the research project for the LTU Luleå University of Technology.

The project, which describes the subject area Media, Graphics and Design Science aims to explore design and colour with a focus on the human sensory experiences and focuses on the creative process and colour expression inside a specific space.

The project takes in consideration the analysis of two emblematic kitchens, by itself a most important room in domestic culture, seen by two artists, in this case the Swedish painter Carl Larsson and the French painter Claude Monet. The first still a central figure in Nordic culture, Carl Larsson's paintings and books have made his family house called "Lilla Hyttnäs" one of the world's most familiar homes, plus the interior design by his wife and the lively family life shown in his famous watercolours, has become almost synonymous with a Scandinavian ideal. Claude Monet's house at Giverny, called the "House of the Cider-Press", is now a museum, also the kitchen were he received his friends.

The aim of the project is to test the similarities/differences of moods in the outward communication of the two spaces and especially colours, in conjunction with the two strong characters that created them.

## 2. Brief introduction and background of two artists and their families

Claude Monet (1840-1926) and Carl Larsson (1853-1919) were two artists, famous all over the world and operating during the same historical period, stretching from the last decades of the nineteenth century to the first decades of the twentieth century. They have become widely familiar to us in modern times through the numerous paintings portraying their private family life.

Several publications, calendars and similar printed items have spread the images of this two homes and gardens making them a symbol of an ideal family environment in our imagination. Especially those images that puts on canvas or paper a moment of bustling happiness during festivities, picnics or other occasions when the family and the guests gathered around the table, have made a lasting impression in people's mind.

Both of the historical houses where they lived, were renewed and redecorated by themselves on an artistic vision and the works thought out with the aid of their wives and children. They are nowadays museums and it is possible to visit them.

Monet's house, with its vivid pink walls and the usually grey shutters repainted green, - colours chosen by himself -, was called the House of the Cider-Press (maison du Pressoir or Le Pressoir). It is endowed with several gardens of his creation and situated at Giverny, not far from the capital Paris, in France. Larsson's

home, “Lilla Hyttnäs” is in Sundborn, in the region of Dalarna in Sweden, again not very far from the capital Stockholm.

These two painters had several points in common. Both were working, as said before, during the same artistic era, in France - Larsson stayed at Grèz-sur-Loing over a long period -, both had two life companions, of which the first died young- Camille Léonie Doncieux and Alice Raingo Hoschedé (Monet) and Wilhelmina Holmgren and Karin Bergöö (Larsson), a large family with many children and owned a much cherished home and gardens that they wanted to share with the world.

Claude Monet, very much beloved by his friends and family, and who were also called “Papa Monet” (Dad Monet) by his second wife Alice’s children, used to receive a lot of people, artists, writers and other leading figures like Sacha Guitry, Octave Mirbeau, Paul Valéry, the brothers Goncourt, Renoir, Pissarro, Sisley, Degas, Cézanne, Rodin, Whistler, Maupassant, Durand-Ruel, Clemenceau the statesman, or simply fiends and admirers, not only French but also from all over the world. He travelled very often especially in Italy and the United Kingdom, and so did Carl Larsson even if in a lesser way, especially in Italy and France. Carl Larsson also entertained relations with the intellectual leading figures, like the painter Anders Zorn, August Strindberg who later became his enemy, Ellen Key and many others, living in a more subdued way a similar life in Sweden.

They had a different family background. Carl Larsson came from a very poor family and grew up in Stockholm. He succeeded in having the opportunity to go to France to study and paint. There he met and fell in love with Karin, a gifted artist and designer, and there he got his first breakthrough. Karin’s father gave them a little “torp”, - a typical Swedish rural wooden cottage -, and a farm as a wedding present. Claude Monet, on the other hand, came from a Parisian high/middle-class family. He entered, being already famous, in second marriage with Alice, which came from a very wealthy family but was ruined and left alone with six children by her first husband. Monet bought propriety in Giverny consisting of a house and other buildings and a large land and garden, to which he added land over time on the purpose to live there with Alice and his children and stepchildren.

While Claude Monet has passed to history mostly for the Impressionism, and his celebrated paintings, especially of the water lilies, Carl Larsson has been a central figure in Nordic popular culture. His paintings and the books he created have made his family house Lilla Hyttnäs one of the world’s most familiar homes, plus the interior design cured by his wife and the lively family life shown in his famous watercolours has become almost synonymous with a Scandinavian ideal.

### **3. Entering an artist’s home as a lunch guest**

This research project focuses on the creative process and colour expression inside specific spaces; in particular it takes in consideration the analysis of one of the most important room in domestic culture, the kitchen. As we are speaking about a kitchen set in a definite historical period, in the years around 1900, and in a middle-class milieu, we will look at two distinct rooms, the kitchen laboratory and the dining room.

The kitchen was at that time the cook's prerogative and the family received and dined in the dining room, often with an open view on the kitchen.

At this point you have to know that while Monet had a very rigid "kitchen Protocol" with meals at fixed times that all family members and guests had to respect, Larsson was less obsessed by food. The Swedish painter introduced a Scandinavian tradition of food in his home whereas the French painter's family wrote down a large number of recipes coming from all over the world and famous restaurants that testimony a rich cuisine performed by their cooks.

Both artists wanted to break with the prevailing brown and dark tones, in fashion in that era, with clear brilliant colours. Japonism and the British Arts and Crafts also influenced them as was trendy at that era, the Larsson's also mixed in Scandinavian folklore in their interior design.

Let's look inside the Pressoir where the guests entered, here Monet's choice of colour was determined by his intention to give the right harmonious impression of colours when the door between the kitchen and the dining room was open. The kitchen is coloured in cool blue shades. It is covered, as traditional in that region, by blue and white Rouen tiles leaving the rest of the walls in an almost cobalt blue colour, and the furniture is lacquered sky blue. Only the copper utensils are gleaming in contrast and the enormous stove. The windows are overlooking the marvellous gardens. The dining room is in a predominant sunny chrome yellow, declined in two yellow nuances, one pale and the other more vibrant. The walls are decorated with Japanese prints of the eighteenth and nineteenth centuries with a dominant blue colour. In Monet's home all the table-cloths were yellow and the dishware were only two, the Creil & Montereau one (Japonism style) in light blue and blue motifs and a white one with a broad yellow rim and blue trim, which Monet himself designed for the more important occasions.

Let's now enter the Larsson's home. Here we can see that green and red is the dominant key, not only inside but also outside. Red is one of the Swedish traditional colours on wooden villas, even it could be also a citation of the English dragon blood's red used by Morris. Much of the existing furniture Carl Larsson repainted white and many details are in a harmonic way contrasting with the dominant red and green in colours such as turquoise, ochre, Gustavian time's grey-green, and "human colour" a light brownish pink and black. Carl and Karin, turning back to their country, took with them the French way of sitting for a long while around the table with their family and friends. The pictures we see in the books like "Ett hem" (A home, 1899) or "Åt Solsidan" (On the sunny side, 1910) are idealized as the environments looks bigger and lighter than reality, with a greater presence of yellow and orange, it could be because he preferred to use water colours. Carl and Karin had also to confront themselves with the existing paints at their time. The famous "Christmas Eve" is representing a dinner held in the Studio not in the everyday dining room. The table-clothes, from the pictures he made, were white or white and red, and the dishware was both white and blue as fashionable at that epoch or white.

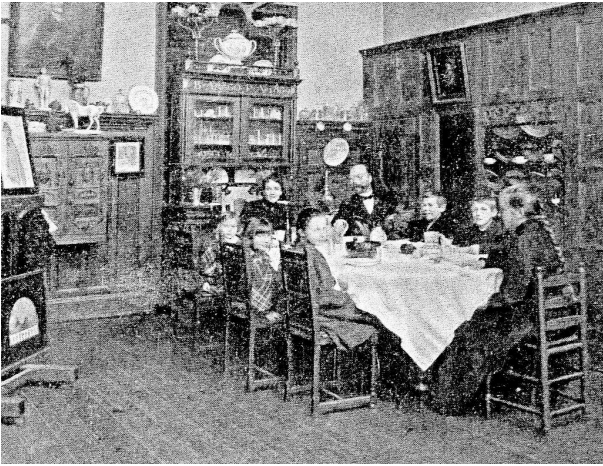

Fig. 1 – Carl Larsson's family. ("La lettura" 1907)



Fig. 2 – Claude Monet (excerpt from Jean-Pierre Hoschedé's book).



Fig. 3 – Monet's house in Giverny (Fondation Monet).



Fig. 4 – A replica of Monet's dishware marked Charles Field Haviland Limoges



Fig. 5 –Carl Larsson "Till en liten vira" (Getting ready for a little game,1901)

#### 4. An artist's colour choice

Impressionist art was based on the use of colour without the use of lines. Monet began, about 1860, to work with a small number of pure colours. Paul Cezanne used to say that Monet was "only an eye - yet what an eye." In one of his letters he describes his palette: "In short, I use silver white, cadmium yellow, vermilion, madder dark, cobalt blue, emerald green. And that's it." Pure black was very rare among Impressionist painters; Monet combined a number of colours in order to obtain a trace of darkness, as he wanted to avoid using black.

Larsson wasn't an Impressionist, but being a water-colourist he gave an impression of bright lightness in his works. We can read in Carl Larsson's autobiography that it was Karin his wife who gave him the idea of portraying their home in books, which sold in massive editions receiving astonishing publicity throughout the world, marking the way for our contemporary selfies. From documents of the Venice Biennales around the year 1900 we can read that the familiar life was already a very popular subject for painters and the Italian Art critic Pica tell us that Carl Larsson

was a remarkably nice person, funny and full of sense of humour and that is conveyed to the public by his marvellous paintings.

Monet created a whole world through his home and gardens of pure colours. The French writer Marcel Proust described the gardens at Giverny, so famous were they before even seeing them, as “a garden in more tones and colour than flowers, a garden, which could be less an old flower garden than a colourist garden, so to speak. Flowers displayed together but not as nature because they were sown so that only flowering at the same time as matching shades, harmonized to the infinite in all ranges of blue or pink. This powerfully manifested painter’s intention in one sense dematerialized from anything but colour”.

## 5. Conclusion

Let’s then come as privileged guests to our two much-loved painters homes. As widely observed (art exhibitions like Highlights and various reviews), many of Monet and Larsson’s works are sort of precursors of our social network selfies. They not only put in pictures their private life but they also embellished it, as much as we may do nowadays using softwares as Photoshop or artistic “filters” used for social applications like Instagram. The great difference is that the two great artists strived to make their personal vision real, creating it materially not only on canvas. Monet was himself a master of thought for his contemporaries and Carl Larsson was inspired by many thinkers of his time. They were united by the common aim of building a sort of personal earthly paradise that would please them and their beloved.

## Short Bibliography

- [1] D. Wildenstein, “Monet”, Fabbri Editori, Milano, 1995.
- [2] S. Bartolena, “Monet”, Mondadori Electa, Milano, 2008.
- [3] L. Quattrocchi, “Case d'artista : compenetrare arte e vita”, La nuova Italia scientifica, Roma, 1989.
- [4] C. Larsson “La casa al sole”, Longanesi, Milano, 1982.
- [5] M. Snodin, E. Stavenow-Hidemark, “Carl and Karin Larsson: creators of the Swedish style”, V&A Publications, London, 1997.
- [6] B. Lindwall, “Carl Larsson: 1853-1919:acquerelli”, Paris: Bibliotheque de l'Image, Artegrafica, Verona, 2001.
- [7] H. Jarild-Koblanck, M. Ahlqvist-Juhlin, M. Moro, “Colour and shape of gingerbread packaging, using Bourdieu’s mapping and a nineteenth century outlook”, Maggioli Editore, Rimini, 2014.
- [8] M. Moro, “Trend colore. Colour trend”, Lo scenario del colore, Aracne Editrice Srl, Roma, 2009.

## **9. COLOUR AND EDUCATION**





# Using colors to teach children how to raise a plant

<sup>1</sup>Elham Atighi Lorestani, <sup>2</sup>Maryam Khalili

<sup>1</sup>MA Student, Department of Industrial Design, Pardis Alborz, University of Tehran, lham.at\_lo@yahoo.com

<sup>2</sup>Assistant Professor, Department of Industrial Design, University of Tehran, maryamkhalili@ut.ac.ir

## 1. Introduction

We are surrounded with variety of colors which bring us different messages. While technology is expanding the human access to the virtual world, it is diminishing the children's access to the physical world in a multitude of ways. Providing children with an opportunity to discover nature even on a smaller scale such as gardening inside will be beneficial for the different aspects of their growth. Children in nature are interested in properties of water and soil. As well as a lot of different concepts in science planting can also be taught to a very young child. Children in early ages are more attracted in colors and they learn better through a fun manner. Including children's favorite colors in their design help them learn the concept in a playful manner. Preschool age is considered to be a suitable age for teaching fundamental concepts such as nurturing plants. Because of children's lack of attention compared to adults, taking care of plants is mostly considered as adults' duty or adults' task. Besides the existing products concentrated on children have not been successful in involving children in the whole stages of plant's growth. This paper presents a new approach for involving children in the whole process of raising plants by help of different color codes or different lights. The concept uses different colors to inform kids about plant's conditions, needs and its growth level. In order to choose the favorite color palette for preschoolers a number of 152 paintings, which were painted over 4 months by children aged 5 to 7, were borrowed from a preschool located in Tehran and analyzed. A plant was chosen and then a number of 46 preschoolers were asked to relate the favorite colors to the plant's needs and its growth level by help of some picture about different stages of plant's growth. The outcome of these interviews was used in a design to improve the involvement of kids in raising a plant. The LED technology can be used to inform children about their plant's status. This research aims to find a solution for involving preschool children in the whole process of raising a specific plant by including different colors.

## 2. Benefits of Nature Experience

Over half of humanity now lives in urban areas. By 2050 this proportion is expected to exceed 70% (Heilig, 2012). This unprecedented shift from rural to urban living is associated with a significant decrease in exposure to natural environments. Taylor, Kuo and Sullivan (2002) showed that among children living in urban environments, those who had every day the views of nature (e.g., a tree outside their apartment window, instead of a view of concrete) performed better on tasks that measured working memory (backward digit span, backward alphabet span), impulse inhibition (matching familiar figures task), selective attention (Stroop color-word task), and concentration (Necker Cube pattern control task). Stress reduction theory (SRT) posits that natural environments have a restorative advantage over artificial environments due to the role that they played in our evolution as a species. More

specifically, nature scenes activate our parasympathetic nervous system in ways that reduce stress and autonomic arousal, because of our innate connection to the natural world. According to ART (Attention Restoration Theory), natural environments invoke a different sort of attention from people – a sense of “fascination,” “being away,” “extent,” and “compatibility” – that may result in the replenishment of directed attention because they are less heavily taxed in these alternative environments. This, in turn, may lead to improved performance on tests that measure memory and attention [1]. New research shows that nature can offer powerful therapy for such maladies as depression, obesity, and attention-deficit disorder. Experience in nature can increase also a child’s power of connection [2].

### **2.1. Benefits of Gardening**

In a nationwide telephone survey of 2,004 respondents, people who reported picking vegetables, taking care of plants, or living next to a garden in childhood were more likely to continue gardening as they aged and to form lasting positive relationships with gardens and trees. Children who garden are more accepting of others who are different from themselves.

Students who are actively engaged in garden projects tend to enjoy learning and show improved attitudes towards education. Students engaged in designing and maintaining gardens show an increase in self-efficacy, pro-environmental attitudes and environmental Stewardship. Gardening has long been recognized as a therapeutic healing activity which can positively impact mental health and well-being [3]. A recent review of literature found that those who participated in a community garden consumed more fruits and vegetables than those who did not [4]. Plants help lower blood pressure, reduce muscle tension related to stress, improve attention and reduce feelings of fear and anger or aggression. Gardening and yard work contribute to healthy and active living both physically and emotionally. Horticulture therapists have discovered that gardening provides a form of emotional expression and release, and it helps people connect with others [5].

### **2.2. Nature Education**

Childhood is the time to encourage and early interests in nature. Children are interested in properties of water, air, soil, etc. The hope is that children who experience nature education will develop positive attitudes about themselves, natural life, and the earth. Because we face so many environmental crises, the study of nature is even more critical today. It is known that young children learn best by interacting directly with their environment through relevant, concrete hands-on experiences, and by having rich opportunities to play. Through nature study, children can learn how they affect the environment as well as how the environment affect them [6].

The theory and practice of preschool education confirm the positive relationship of children to nature and the individual range of emotions that have special influence on the behavior of children to nature. In more recent time it is more obviously the pedagogic need for seeking new forms of contact with nature, which would give the child not only the information but also the emotional saturation. As children grow and become more mature their research activities are becoming more complex.

Knowledge in the child's head arrive in a very complex way: through interaction with objects, living beings and other individuals, the senses and thinking operations, the emotions and experiences. Some authors believe that the direct contact of children with nature should be formulated as a pedagogical principle for environmental education [7]. Environment-based education dramatically improves standardized test scores and grade-point averages and helps children to develop skills in problem solving, critical thinking and decision making [2].

## **5. Pre-Schooler**

In the pre-school period, the worlds of children are remarkably creative and surprising. Their imagination is highly developed and this automatically improves their cognitive perception regarding to this world. Children of the pre-school term have strong tendency to be curious, to search, to investigate and have a strong sense of imagination. Today, the studies made in the neurology and psychology areas have proved that brain development and mental activities in pre-school education have been developing in a great place.

In the pre-school period, science activities provide a significant environment for the kids' developing their cognitive skills [8]. Pre-school educations are critical years and form the basis for further education in ensuring success of an individual [9]. Preschool children are busy learning about the world around them. They ask lots of questions and they love to imitate adults. They like to try new things and often take risks [10].

### **5.1. Early Education**

Education plays the main role in the development and advancement of societies. In other words, education that helps science and technology to improve is in a vicious circle with countries that have the purpose of facilitating the life and increasing life standards. Piaget in his studies of explaining cognitive processes also demands that children do not take knowledge only from adults instead they develop their own way of understanding the world [8].

There is no doubt anymore that early childhood education is a key stage of human development, bringing significant contributions to the personal, social, emotional and cultural development of the child. Moreover, it has already been proved that investing in this stage of education bring a return of investment even higher than investment in universities [11].

According to Piaget, mental capabilities that children own in certain ages, enable them to show different emotional behaviors. In fact there is a direct relationship between child's growth and learning. Children are directly experienced the space when trying to perceive them and even they try to symbolize the environment. These symbols and all the activities and actions of their behaviors are the aids to get the best possible situation. Children show the symbols in their games and drawings best, in other words, children's game is their efforts to touch and feel and control the world and become familiar with it [12].

## **7. Color Education**

Color is an important topic for all the disciplines, in art, architecture, physics, chemistry, psychology, physiology, biology, literature, and health. It is also an undistinguishable aspect of everyday life. Color is also a language, it conveys the messages faster than anything else. It is stronger than words and faster than speech. The contacts of the human beings to the world are through the senses. People obtain perhaps the largest amount of information about their surroundings from the visual sense and color plays a very important part in this flow of communication. Color is one of the most important architectural elements that affect the quality of environments. It is a vital aspect of perception of life.

Color is the enhancer and modifier of space and form, it is a symbol and it is the generator of mood. Color can be subtle or dramatic, capture attention or stimulate desire. Color is a part of total sensory experience of our environment and contributes immeasurable beauty to the visual world. As an integral part of our perceptual system it helps us to identify and define objects in space and acts as a signaling device, which is evidence of certain conditions, conveying information about our surroundings. Color motivates people in a way that is largely subconscious and it is difficult to say where physical, visual processes end and mental processes begin.

Color helps to draw attention from the self to the environment, or vice versa, which affects the mood of the humans. According to the studies done on psychology and psychiatry, it has been found that response to form is seems to arouse intellectual process, whereas the reactions to color are more impulsive and emotional [13].

Colors can affect neuropathways in the brain and create a biochemical response. So when the correct color is found for a particular person's problem subject, that subject becomes much easier and the student experiences the joy of success. Color helps concepts becomes more logical and opens the mathematical process, makes reasoning and memory easier. Color opens creativity. The brain sees and remembers color first [14]. Color can increase arousal, and arousal can increase memory, then it is possible that we could say that color can increase memory [15].

### **7.1. Color and Children**

With children the issue of color is even more sensitive. Children are very pure, excited, and full of imagination, and they are always learning new things and discovering new emotions. Color is one of the best ways they can represent these feelings they realize [13]. Similar to how sound waves affect the acoustic nerves and in turn will cause a reaction, color also affects the visual nerves and again will provoke different reaction in people and animals. Color has a special language, together with its properties, the way they affect different children's social behavior and psychological manners, the mechanism under which the children will react to different colors. Because of the energy which is within the bright and happy colors, the kids naturally tend to like lighter and happier colors more than darker and sad ones [16]. Children response to their environment and new things immediately. Color is one of the most important things in childhood. They recognize their toys and clothes through colors, even if they don't know the name. Therefore it can be used significantly [17].

The preference for color is one of the most intensively researched areas within the field of color. In a study conducted by Heinrich Freiling from the Institute of Color Psychology, color preferences of children, according to their ages, has been tested. The study has been conducted on ten thousand children in all corners of the world between ages 5 to 19. The general results are that black, white, gray and dark brown are rejected by children between the ages of 5 and 8; whereas red, orange, yellow and violet are preferred. As a rule, most persons, young or old, will prefer light colors to dark ones, pure colors to grayish ones, and primary colors to intermediate ones. During the early years of life, warm colors- red, pink, yellow, and orange- seem to be preferred more. The color preferences during the childhood are in the order of yellow, pink, red, orange, blue, green, and purple.

In a practical sense, young people, who are more adventurous in their choice of colors than their elders, usually prefer brighter and stronger colors than their elders. They choose colors on the assumption that they will be able to change it after a short period of time [13]. Children tend to use darker colors for negative topics, and these darker colors (i.e. brown and black) are typically ranked and rated as the children's least preferred colors overall [18].

## **8. Color and Design**

Children are more color dominant than form dominant. All of the elements of design help the designer convey to the observer the various aesthetic, social, political, and historical messages that are purposefully injected in the structure. Color plays the major role in conveying the messages of the man-made structures. In most cases, it is easier to understand these messages through color than the design itself. Color is used to serve more important functions than mere beauty and pleasure.

It is indicated that the children's needs and feelings must be taken into account when designing something for them [13]. Most children at the age of 3 to 6 years show strong interest to colors, but at the age of 7 to 9 years pay attention to forms [12].

### **8.1. Color coding and meaning**

Children start to recognize their environments through the use of color. Color also has a definite message conveyed to it about the nature of learning process and the comprehensibility of the environment. The colors of the environmental components draw attention towards these components, demanding that the children utilize them as elements of learning. An application of color coding in the primary school environments would help the children come to understand and recognize the environment where their education is taking place [13]. Using coloured lights for encoding information can greatly improve the observer's understanding of the information and his/her capacity for remembering it.

Word association tests show that most people will link many shades of green lighting to nature. Because of its association with nature, it appears as both refreshing and fresh. Blue is strongly associated with sky and water and perceived as a constant in the life of humans [19]. The red color is the most impressive vibration in the spectrum and reflects the excitement, speed, power, pleasure and passion. Yellow is psychologically the happiest color in the spectrum with a sense of warmth, optimism and joy. Orange represents friendship, joy and adventure. Bright orange

has the highest effect on the eyes. Dark green represents stability, growth. Purple is a color with the sense of monarchy, nobility, power and luxury. Pink encourage people to love and is known as a feminine color [20].

## 8.2. Play and Education

Game and mobility are the best way of child's natural action and they are considered as the most suitable way to talent's flourish and growth [21]. Play has an important place in early childhood education and it also has a meaningful place in children's daily life. Many scientists studied on play in early childhood education and noticed that play is important for learning and development. There are a lot of descriptions of play, meaning different theoretical perspectives of learning and development. Play facilitates learning relevant processes such as rehearsing, practising, repeating, imitating, exploring, discovering, revising, extending, combining, transforming, testing [22]. Donnell (2011), highlighted that young children learn best through play, games, stories, art, puppetry and social interaction. Froebel (1970), a German philosopher on early childhood education discovered that all the tasks given to children should have elements of play and the objects used in the learning process can arouse the interest of children towards learning. Locke (1632-1704) affirmed play as a necessary and important part of the educational process and children learn faster through the play method because they love fun [23]. Play for child is equal with speaking for an adult, play and toys are the words of children. Play provides the children with possibility of experience and direct interactions with environmental factors. Play not only influences on the intellectual and observable behaviors, but also irrevocably influences on physiological structure of his brain [24].

Babies and young children are powerful learners, they are not passive learners. They enjoy participating in 'hands-on' and 'brains-on' activities. Play refers to any mental or physical activity even done by group or individual and results in joy and satisfaction. "Fun can obviously change behavior for better" is the statement that surrounds "The Fun Theory" initiative by Volkswagen [17]. Children by nature love toys. Toys certainly do possess the magic of capturing our imagination and attention as they are the sources of fun that activate the adrenaline glands. Toys can provide motivational and experiential links between science concepts and everyday experience [25]. Teaching will be more effective if learning activities include conceptual play. Use of child-friendly concepts which notes child-friendly should have special features included cartoon drawings of children, animation, colorful objects, simple language (e.g. storytelling), and activities with game elements [26].

## 9. Methodology

Product design and development by Ulrich and Eppinger is chosen as the design method for this study. This method is a sequence of steps which converts inputs to outputs. The sequence of steps is as follow (Fig.1) :

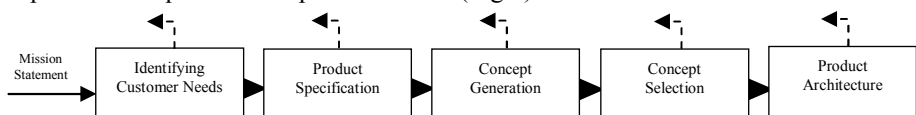

Fig.1 – Steps of Product Design and Development Method, Karl Ulrich & Steven Eppinger,2000.

## 9.1. Identifying Customer Needs

As Preschooler aged 5 to 7 is considered for this study, a private boys-preschool (named Mofid) located in west part of Tehran city was selected and the process of gathering essential data has begun. By considering the school's fundamental disciplines different tools for collecting data were used such as: interviewing with children, observing their play and identifying their preferences, holding short talk by children about plants and their needs, photographing and filming, visiting a greenhouse by children, purchasing some plants for them and asking them to participate in a project named "build a suitable place for your plant" (Fig.2). The data collected in this step was translated to customer needs and then valued according to their importance for customer.



Fig.2 – (from left to right) Children of Mofid Preschool visiting a greenhouse (November 2015); Work of one of the children for the project "Build a suitable place for your plant!".

## 9.2. Product Specification

After identifying customer needs and before generating any concept, the product specifications are determined. These specifications will be reconsidered after selecting the final concept. The most important needs is mentioned in the table below (Tab.1). After identifying needs, indexes which response to these needs were identified as well and matrix of need-index was provided. Then the specifications were determined by using the indexes. The specifications can be change according to the final concept and manufacturing limitation.

Need Number	Needs	Importance
1	Encourage child to irrigation	4
2	Include a mechanism as reminder of irrigation time	5
3	Provides well protection for the plant	3
4	Inform child about plant's needs	5
5	Consistently inform child about plants' growth and involve him in the process	5
6	Involve child's favorite colors	5
7	Use child's favorite characters	4
8	Use elements which is attractive for kids such as lights, sounds and motion	5
9	Remind child that the plant need more light	4

Tab.1 - Customer needs and their importance

### 9.3. Concept Generation

This stage includes a 5 steps method for generating concepts. In this stage the problem was defined and broken into sub-problems to find solutions (Fig.3).

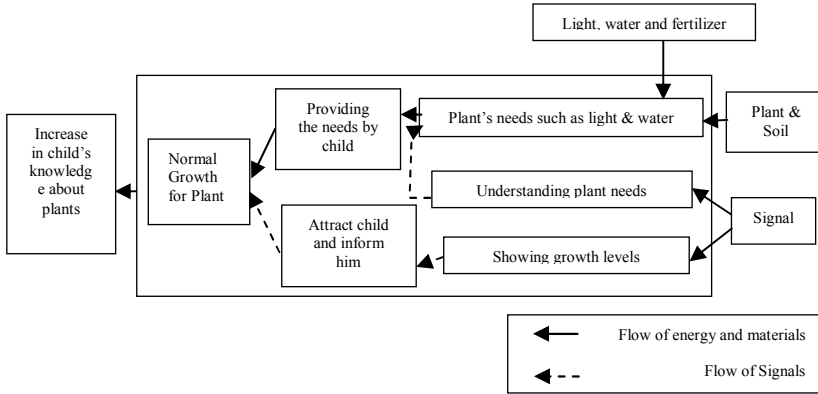

Fig.3 – Function of product by breaking problem into sub-problems

After these steps the existing product which answered the sub-problems were found (external research) and along with the solution provided by the design team (internal research) used as the inputs for the next step of this stage. At systematic analysis all the solutions were categorized and divided for easier comparison (Fig.4 & Fig. 5).

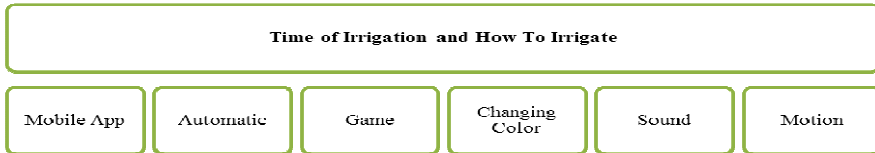

Fig.4 – Concept Tree for irrigation sub-Problem

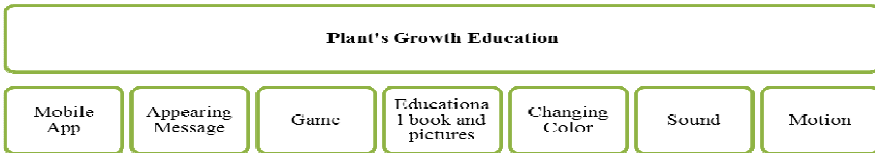

Fig.5 – Concept Tree for plant's growth education sub-problem

At final step of this stage all the concept were analyzed by considering manufacturing limitation, product specifications and consulting with expert preschool educators. The colors, motions and sounds are decided to be the attractive elements for children of preschool and then 3 final concepts were presented (Fig.6).



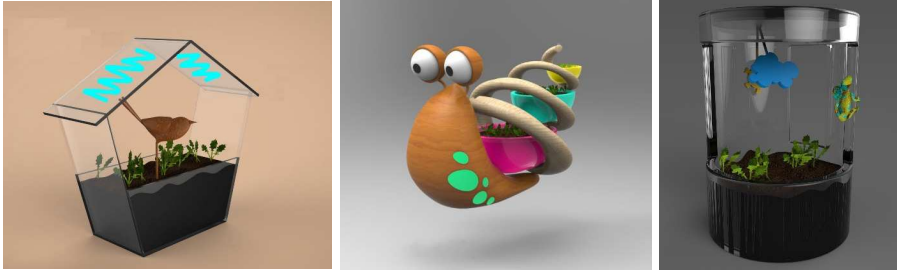

Fig.6 – Three final concepts

#### 9.4. Concept Selection and Product Architecture

By using Paired Comparison Method (PCM) and parameters taken from customer needs, the 3 final concepts were graded. The final concept uses a snail character because children of this age love animals. There is also a harmony between the purpose of this study and where this animal lives. Three pots are located inside the helix shell. The design works for one plant so the pots must be planted with the same seeds. Using a plant which grows fast is easier for children, so after studying different seeds, radish was selected as a fast growing plant which is edible. Lights with different colors are located on different parts of the helix with symbolic shapes of plant at its different growth level. At each stages of the growth a specific light with a specific color and shape turns on and for saving energy it turns off after 24 hours. Five stages is considered for radish growth which are: seed, germination, appearance on the soil surface, grown leaves and ripped radish. In times of watering, the watering light is appeared, the snail's eyes slowly get closed and it gives a realistic feature to the animal. Spots on the front of the snail is luminescence and absorbs the daylight and glows a night light for child's room (Fig. 10).

#### 9.5. Color Selection Method and Color Arrangement for Final Concept

In order to choose the favorite color palette for preschoolers a number of 152 paintings, which were painted over 4 months by children aged 5 to 7, were borrowed from Mofid boys-preschool. These paintings were done by boys only in their preschool and with free topics (Fig. 7). Paintings were analyzed and the most common colors used got extracted. The percentage of each color is shown in Fig. 8:



Fig. 7 – Paintings done by 5 to 7 years old boys from Mofid Preschool

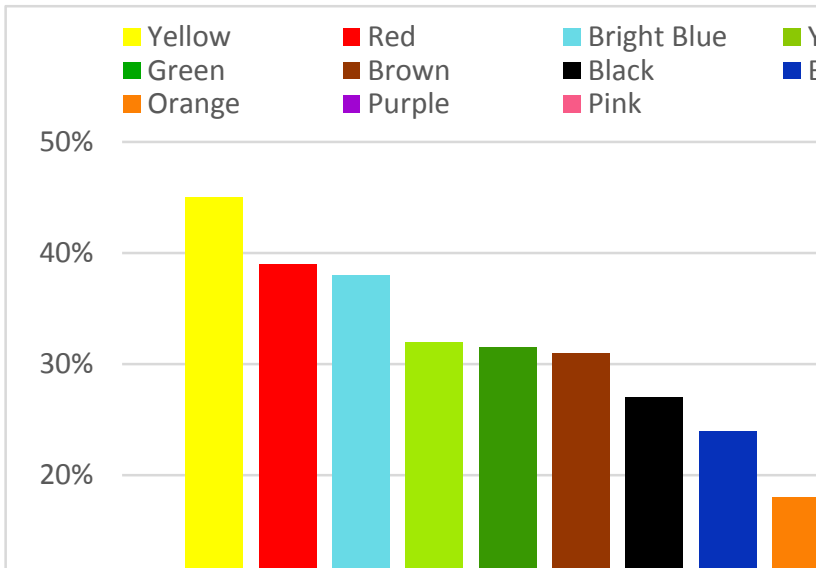

Fig. 8 - Most commonly colors used in 152 paintings done by Moifid Preschoolers

As shown in Fig. 8, yellow by 45% was the most repeated and favorite color in the paintings and after that red, bright blue, yellow green, green, brown, black, orange, purple and pink by respectively 45, 39, 38, 32, 31.5, 31, 27, 24, 18, 13 and 12 percent. Favorite colors in these paintings confirms the findings of previous researches and indicates that children of this age love bright and primary colors although we can't generalize these findings to all boys and girls.





From the favorite colors of the previous section, six color codes is needed for five stages of radish growth and watering time. Nine cards colored in yellow, red, bright blue, yellow-green, green, brown, black, blue and orange, were prepared along with plant's growth cards and the watering card are prepared (Fig. 9). Then 46 preschoolers were asked to relate the favorite colors to the plant's need for watering and its growth levels by help of these cards (Fig. 9). This cards matching took place in Moifid preschool environment and in two mornings from 8:30 till 11:30. All the cards matching were photographed and the most repeated colors selected for each stages of growth or the watering time were chosen as the final color codes. The final color arrangement is as shown in Tab. 2. Orange, yellow-green, yellow, green and red are chosen respectively for the seed, germination, appearance on the soil surface, grown leaves and ripped radish stage and light blue is the color code for watering time.



Fig.9 – (from left to right above) Colored cards along with plant's growth; Cards matching of preschoolers of Moifid; (bottom) Selected color coding for final concept.

## 10. Result

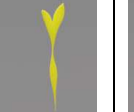
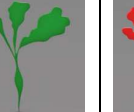
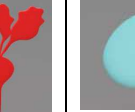
The color codes are used in order to inform children about different stages of growth for red radish. To reach such design an electronic circuit is needed. The main element for the circuit is a microcontroller which has to be programmed. Prior to the programming the exact time for each growth stages of radish (begins by planting the seeds) and watering were found and are shown in Tab. 2. The exact program must be written by considering information in Tab. 2. By connecting the programmed microcontroller to the circuit containing colored LEDs and turning the circuit on, the program runs and demonstrating the process of growth begins.

Name	Seed	Germination	Appearance on Soil Surface	Grown Leaves	Ripped Radish	Watering Time
Color Code and Icon						
Day	1	4	7	15	21	1-2-4-6-8-10-12-15-18-21

Tab. 2 – specific days for each stages of red radish growth and watering

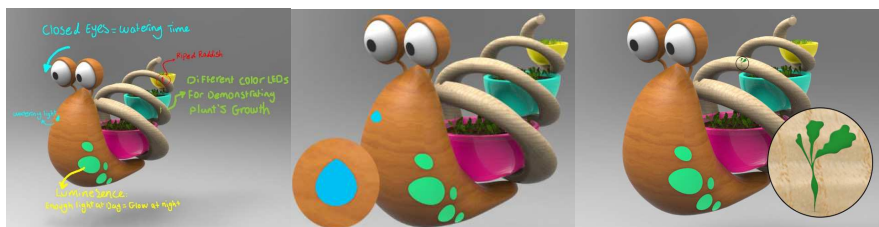

Fig.10 – (left) Final function; (middle) Watering time shown by blue LED; (right) Grown leaves shown by green LED

## 11. Conclusion

This study was undertaken to find the favorite color for preschool age (5-7 years old) and use them as color codes in order to inform kids about radish's growth stage and its watering need. The most favorite colors was extracted from analyzing 152 painting done in 4 months by Mofid preschoolers and then 46 of these preschoolers were asked to related their favorite colors to each stages of radish growth and also its watering need. The final object represents a snail form with 3 pots located on its helix shell. All 3 pots must be planted with radish seed and after planting, different icons related to each growth stages and also the watering turn on by different colored LEDs. Child sees the LED and gets informed about his plant's growth and its needs. There are also some luminescence spots located on the snail's body which absorb lights during the day and act as a lamp at nights for the child's room.

## Bibliography

- [1] G. N. Bratman, G. C. Daily, B. J. Levy, J. J. Gross, "The Benefits of Nature Experience: Improved Affect and Cognition", Elsevier Journal, Landscape and Urban Planning,, 2015, pp. 41-50.
- [2] R. Louv, "Last Child in the Woods: Saving our Children from Nature-Deficit Disorder"
- [3] "Benefits of Gardening for Children", Children, Youth and Environments Center for Research and Design, University of Colorado at Denver and Health Sciences Center, 2009, Fact Sheet
- [4] D. C. Castro, M. Samuels, A. E. Harman, "Growing Healthy Kids", American Journal of Preventive Medicine, Published by Elsevier, 2013, PP. 193-199.
- [5] Landscape Ontario.com
- [6] J. Bullock, "Helping Children Value and Appreciate Nature", Day Care and Early Education, pp. 4-8.
- [7] S. S. Veselinovska, S. Petrovska, J. Zivanovic, "How to Help Children Understand and Respect Nature?", Procedia Social and Behavioral Sciences, 2010, pp. 2244-2247.
- [8] E. Ulu, A. Kiraz, "Science Education and Cognitive Development in Updated 2012 Pre-School Curriculum", Procedia, 2014, PP. 438-451.
- [9] M. Y. Abbas, M. Othman, P. Z. M. Abdul Rahman. "Preschool Classroom Environment: Significant upon Children's
- [10] L. Oesterreich, "Understanding Children: Disciplining Your Preschooler", Iowa State University, PM 1529b, Revised, 2001.
- [11] L. E. Ciolan, "Play to Learn, Learn to Play. Creating Better Opportunities for Learning in Early Childhood", 5th International Conference EDU-WORLD 2012 - Education Facing Contemporary World Issues, Procedia, 2013, PP. 186-189
- [12] M. Anbari, H. Soltanzadeh, "Child-oriented Architecture from the Perspective of Environmental Psychology", European Online Journal of Natural and Social Sciences, 2015, Vol. 4, N. 3, pp. 137-144.
- [13] Z. Basoglu, " A Comparative Study on Color Preferences of Children for Their School Environments: Two Private Schools in Ankara", Thesis for the Degree of Master of Fine arts, Dep of Interior Architecture and Environmental Design, Bilkent University, 2002, pp. 10-66.
- [14] [www.cerconelearning.com](http://www.cerconelearning.com)
- [15] L. Huchendorf, "The Effects of Color on Memory", Journal of Undergraduate Research, 2007.
- [16] M. Mohebbi, "Investigating the Gender-based Color Preference in Children", International Conference on Education & Educational Psychology 2013 (ICEEPSY 2013), Procedia, 2014, PP. 827-831.
- [17] D. Maani, G. Akhavan, S. Tooshnejad, "The employment of gamification in teaching colors to children", Colour and Colorimetry Multidisciplinary Contributions, Vol. XB, AIC Press, pp. 477-486, Milan, 2014.
- [18] B. Esther, B. Barrett, M & D. Alyson, "Children's Color Choices for Completing Drawings of Affectively Characterised Topics", Journal of child, 2003, Vol. 44, N. 3, pp. 445-455.
- [19] M. Khalili, "Coloured lighting in product design experience : spatiotemporal and visio-emotional dialogue", Colour and Colorimetry Multidisciplinary Contributions, Vol. IX B, AIC Press, pp. 104-113, Milan, 2013.
- [20] M. Khalili, L. Elyasi, "Design of colored lighting for natural wake up process", Colour and Colorimetry Multidisciplinary Contributions, Vol. XB, AIC Press, pp. 134-144, Milan, 2014.
- [21] F. Malekian, M. Baghbanbashi, "Investigating the Role of Childish Games (Based on Carl Gross Pre-Training Model) on Social Contexts Learning Reinforcement in Kermanshah District 3", world conference on psychology and sociology, Procedia, 2013, pp. 784-789.
- [22] E. Ozdogan, "Play, Mathematic and Mathematical Play in Early Childhood Education", Procedia, 2011, PP. 3118-3120.
- [23] S. Madhawa Nair, N. Mohd Yousef, L. Logeswary Arumugam, "The Effects of Using the Play Method to Enhance the Mastery of Vocabulary among Preschool Children", 5th World Conference on Educational Sciences - WCES 2013, procedia, 2014, PP. 3976-3982.
- [24] T. Aghajani Hashtchin, "Role of Play in Social and Intelligence of Children", Procedia, 2011, PP. 2272-2279.
- [25] B. Kian Lim, "Toying with Science", 6th International Conference on University Learning and Teaching (InCULT 2012), Procedia, 2013, PP. 72-77.
- [26] M. Maziah, R. Saemah, J. Nooraziah, "Child-friendly Approches: Choosing the Best Educational Psychology Tool to Teach Healthy Behavior for kids", Procedia, 2015, PP. 435-441.

# The effect of color perception on individual skills for children with autism

<sup>1</sup>Maryam Khalili, <sup>2</sup>Tahereh Khodayarian, <sup>3</sup>Rasul Fesharakifard

<sup>1</sup> Assistant Professor, Department of Industrial Design, University of Tehran, maryamkhalili@ut.ac.ir

Master of Industrial Design, University of Tehran, nafiseh.khodayarian@gmail.com

<sup>3</sup> Assistant Professor, New Technologies Research Center, Amirkabir University of Technology, fesharaki@aut.ac.ir

## 1. Introduction

Autism comes from the greek word “autos” meaning “self” [1]. Autism is one the pervasive developmental and neurological disorders with the psychological symptoms in origin. It is more common in boys than girls (about 4 times). The socio-economic level of parents or their lifestyles do not play any role in autism. Autistic children are considered as a group of exceptional children with a developmental disorder characterized by deficits in communication-nervous which limits the social relations, activities and interests [2].

The prevalence of autism has been increased dramatically for various reasons. In early 2000, the prevalence of autism was estimated 1 in 335 [3], but the rate in recent years is increased to 1 in 150, especially with regard to autism spectrum disorder [4]. The studies in Iran estimate that there are more than 2,500 children aged from 4 to 5 years old who have autism [5].

Children are born with this disease but its symptoms can be observed before age three. The observed behaviors of these children are not normal, because autism affects the development of normal brain areas in which there are social interaction areas and communication skills reflections. There is multi variety of autism degrees but generally the social issues are more problematic. These children have many problems to use multiple verbal and nonverbal behaviors to create the social communications and the activities related to play [6]. Due to the exceptional characteristics of autistic children in terms of performance and mental differs, they need the daily activities programs to achieve the right consistency required specially in their individual life. Autistic children between three to five years old show less social understanding. They tend less to have the relations with others spontaneously; their emotions do not respond to the verbal communication and do not turn into the decision; but they respond to their primary care assistants. So it is important to create the products and toy equipments that contribute to the formation of some basic skills in individual and social life of these children. For example, in a study conducted by Chang et al., They were able to improve the social skills of autistic children by training programs [7]. In another study which is done by Parsons et al., (2006) and Fulysh and Christine (2001), they have reduced the social problems in autistic children with some mental and physical activities [8] [9].

There are several educational treatments and techniques for children with autism such as “TEACCH”, “PECS”, “Social Stories” and “Art therapy”. This paper aims to improve the social skills of autistic children by colors using “PECS” techniques. The objectif of this study is to improve the motivational factors through color, colorful lights and sounds and to facilitate communication and interpersonal interaction. Some items such popular picture books and toys, computer and

audiovisual equipments [10], musical devices [11] and adapted robots to fit for play or communication with autistic children [12] are already used in educational intervention and rehabilitation. In order to implement this project with educational centers for children with autism all types of support as well as questionnaire, interview, photography, video and observation were used. Autistic children with limited verbal speech are often excluded from design research. This paper bridges this gap by selecting and adapting design methods that invite children to be active participants within the design process. This study illustrated how autistic children's interaction can create an enjoyable and meaningful game for them by using colors and lights.

## **2. Social skills in autistic children**

Social skills contain all types of behaviors, language and attitudes that occur in interactions with others. So to assess the social skills, it must identify the strengths and weaknesses of children through their interactions with others in each environment. The autism clasement consists of the following disorders:

- Extreme Autism
- Asperger disorder
- Generilized developement disorder not specified
- Rett syndrome
- Childhood disintegrative disorder

Social dysfunction in children with autism is visible from their birth. Two common visible signs are the lack of eye contact and the coordination with the other side of things. Social disorders continue in autistic children and the lack of play and interact with others throughout the childhood periode limit also this function for them. Autistic children show also a profound lack of social behavior and often do not express their emotions in public. Verbal autistic children tend to echo words or phrases said by others if they repeat more times. Children with autism disorder are significantly less accurate at color memory, but according to PECS technique the repeation of color meanings could be percieved by them as an awareness message. Despite of different symptoms and performance levels of autism disorder, all of them are common in poor communication, which affect their individual and social skills.

### **2.1. Disability in communication**

A research has shown that more than a third of autistic children do not gain speech function, while they are able to learn how to use language.. This study shows that more than 75% of autistic children fail to learn if there are the echoes around them and they speak often with unusual songs. Autistic children's perception of language is often literal [13]. Many researchers believe that the behavioral traits associated with autism, such as aggression and self-injurious are the results of communication failure.

The available research suggests that education of colorful messages and appropriate ways to communicate to autistic children who do not have the ability to speak

reduce such behavioral problems for them and help them to have a better individual skills in their daily activities.

### 3. Communication using Picture Exchange System (PECS)

PECS has developed by two clinical psychologists A. S. Bondy and L. Frost about 30 years ago. It focuses on the initiation component of communication and the use of innovative methods to help children with autism spectrum disorders. In this method all prompts are not used, but some learners using PECS also develop speech. The ultimate goal of PECS method is the development of spontaneous communication. This method also does not require long-term training or expensive tools.

Because of the limited information of autistic children about their manual capabilities, they have often a lot of interests compared to normal children when they are playing with their toys or other objects. According to studies, the method of Picture Exchange Communication can encourage autistic children to communicate and lead the training course to finish in a relatively short time. This method is more understandable if the pictures have the sense of sight or touch and even if they interact with other senses, for example, integrate them with specific musical rhythm to stimulate the sense of listening. This research shows that using complementary and alternative methods of communication such as sign language can be more effective in improving the communication skills of autistic children.

According to the National Research Advisory Committee Many autistic children have higher visual processing capabilities and will be able to use their icons as a way to communicate with others [14]. Autistic people are better in visual skills compared to the verbal skills. They are consistent with the visual style icons and intuitive ways to understand the meaning providing the association process [15]. Using visual games help the autistic children to be able to do more interactions in social contexts; because these games provide the information in a way that is easier to understand for them.

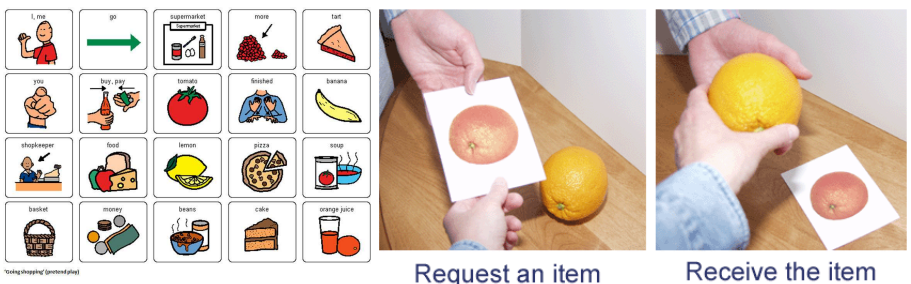

Fig. 1 – Some examples of PECS tools for autistic children.

### 4. Vision and color perception in autism disorder

Research into the vision and color perception of persons with autism has found enhanced perception [16][17][18], visuo-spatial perception [19][20] and discrimination of novel stimuli leading to theories that those with autism show superior visual discrimination [21][22] or an enhanced perceptual functioning

[3][24] that may extend to a large number of perceptual domains [25]. According to another study an impaired perceptual ability in autism has been shown for some other domains such as motion [26][27][28][29]. Parents, teachers and autistic children themselves suggest that children with autism may perceive color differently [30]. Despite many suggestions that color perception and vision may be atypical in autism, there has been little experimental studies of whether this is the case. Kovattana and Kraemer [31] found that a nonverbal group of children with autism preferred to use color and size cues rather than form on a sorting task. However, Ungerer and Sigman found no significant differences in children's sorting by function, form or color [32]. It is important to indicate that there may be differences in attention to color, for example Brian et al. found that color unexpectedly produced a facilitation effect in persons with autism [33]. In the current study we investigated the color perception of children with autism and the way in which color may shape those with autisms' toy equipment.

## 5. Design Process

The design process of an educational colorful game for autistic children needs the interests and limitations of real users. To achieve this goal, there is a new reflection on all different areas and interactions using PECS method in a game dedicated to autistic children.

According to D. Norman (1986) a user centered design must facilitate use, enhance readability and use a graphic language to communication. From the standpoint of Nielsen (1993), usability or performance of the products is the same concept, but there is more attention on other factors such as learning ability, excellent performance and minimize errors.

Based on these conceptual definitions, and to involve the users' needs, five principle keys are defined as the main requirements of product design and development for autistic children. This approach contains also the Maguire theory on user centered design :

1. Existence and presence of autistic children in all development design process and identifying them.
2. Evaluation of design based on autistic children tests.
3. Explanation of iterative design process with users.
4. Getting feedback on autistic children experiences.
5. Accumulation of skills and different perspectives of product design for future.

Autistic children, parents and educators of children are three user groups who are in relation with intended product. In this research and considering all personnels who accompany autistic children, design process is created regarding to each group in different sequences.

A number of 32 mothers of autistic children were interviewed. They have sometimes more than one child with autism disorder. Some important points extracted from the interviews with parents about their autistic children are :

- Their children show interest and desire to play at home.
- They do not have access to a real and specific physical activity or toy equipment.



- They do not enjoy their current toy equipments.
- Their games are often done on a 2D surface and they like another.
- Sometimes their educational games are boring for them.
- They like the repetitive stereotypes that integrate in a game.
- They like to see the inside and the other side of their toy equipments.

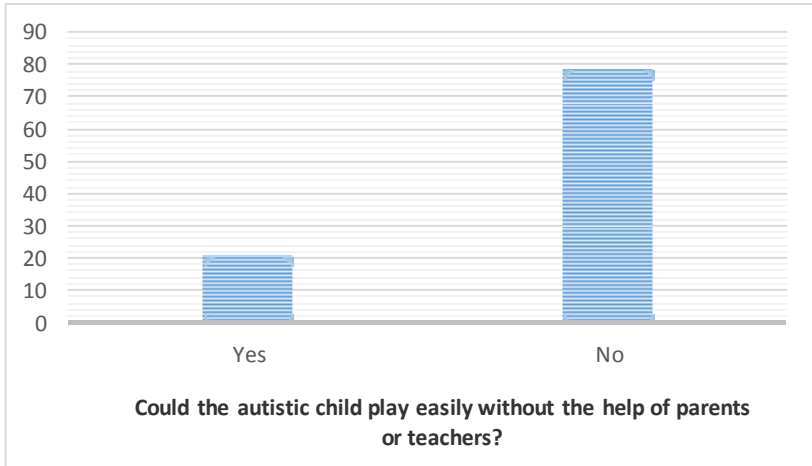

The parents indicate also that their children are interested in water play, aligning the stereotypical toys, clothes, etc., creating sound with various objects, running, hiding, watching television and listening musical programs. They are interested in illuminated objects and interact with these objects spontaneously.

Other findings from the survey of mothers said that :

- The autistic children have a lot of difficulty to play with others.
- Sometimes they duplicate a style of play for all type of game.
- They have the preferred toy equipments despite their numerous toys.
- They are not interested in group games and do not enjoy playing with others.
- They do not speak when they are playing with others.
- They are so interested to play with mirrors.

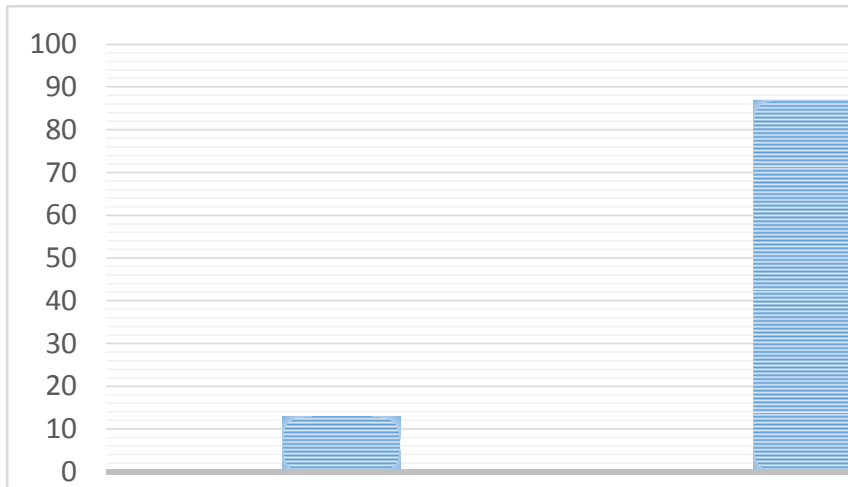

To define a typical autistic children in our case study there are six characteristics. The child:

- has many difficulties in his/her work.
- can not go to the bathroom alone.
- needs the small tasks to do to finish the total task at the end.
- needs a lot of time to do a small task.
- forget each task after doing it and needs to do it again to get it as a habit.

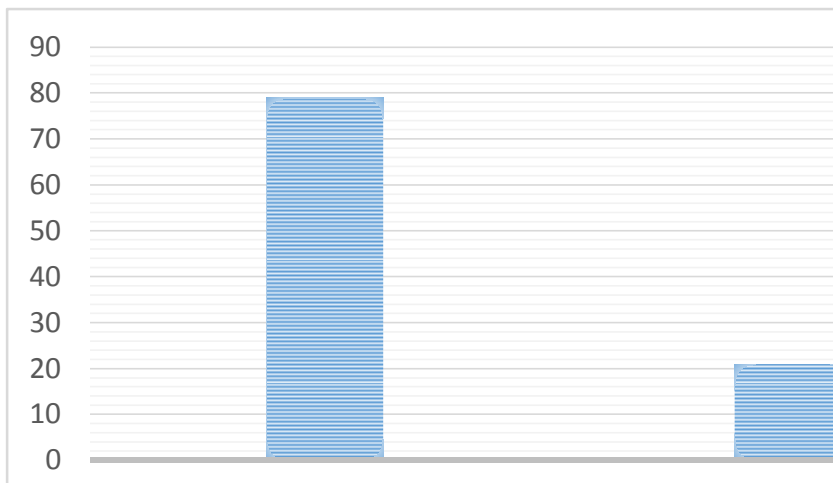

One of the main obstacles in treating autistic children is the lack of motivation. A common problem is that these children stop work quickly and are saturated always. It seems that these children have only the very basic supplies such as food as an

exciting element. The persuasive approach proposed the solutions that amplify the variety of activities by using the prizes that are given to children. In this experiment we assessed the hypothesis that color perception is atypical in children. To be able to get a chromatic difference between stimulus, they were made on a large surface. There were four colored stimulus in the final product. Only two principle colors (yellow and green) are selected to put on the background. The other elements are colored by purple and blue color. The form stimuli were abstract line drawn shapes.



Fig. 1 – Two autistic children doing the tests with a colorful puzzle.

### **5.1. Participants**

Thirty two persons took part in the study, 17 autistic children and 15 their mothers. The interviews were done with all participants but the experimentation was done only with children. The experiments took place in Peik Honar specialized school for autism in Tehran.



Fig. 2 – The application of product in test with the autistic children in school.

### **5.2. Procedures**

A popup book is presented to the participants. Each participant completed the puzzle both the visual search task and the matching to sample task, with the order of task. The tasks are the ordinary tasks divided in small tasks. Once it was clear that the children understood the task, the children completed six color grids with six shape grid in a randomized order. If the child's response was correct the green LEDs are illuminated and an encouraged sound is offered to children; but if this response is incorrect the children understand their errors by red illuminated LEDs. Children were asked to complete the puzzle as it became green with a musical sound.

## 6. Result

The percentage of correct responses for green color was calculated and there was a significant main effect of illuminated LED green light and musical sound on the correct responses. This experiment shows that there is a significant difference between the group who completed this puzzle without colored light and sound and the children who follow the color and light to give the correct response. The first aim of this experiment was to see whether the findings of one page could be replicated for another puzzle detecting another task. A second aim of this experiment was to investigate the strength of colorful games to teach the individual skills in the quotidian life of children. Despite the finding that children with autism have less accurate color perception, these children have typical categorical perception of color. This suggests that using color, light and sound can stimulate their perception and encourage them to do the given tasks. Gaining a better understanding of color may lead them to a greater understanding of the interaction with the objects around them. This effect is found on three different tasks tapping three different perceptual processes: going to the bathroom, changing the clothes and brushing the teeth. In each task there are three reflections: color search, color memory and chromatic detection. Therefore, further research which investigates the broader context of color for specified activities with autism is also needed to explore the alternative responses. Nevertheless this study represents an important first step to understanding how these children interact with and perceive the world of color.

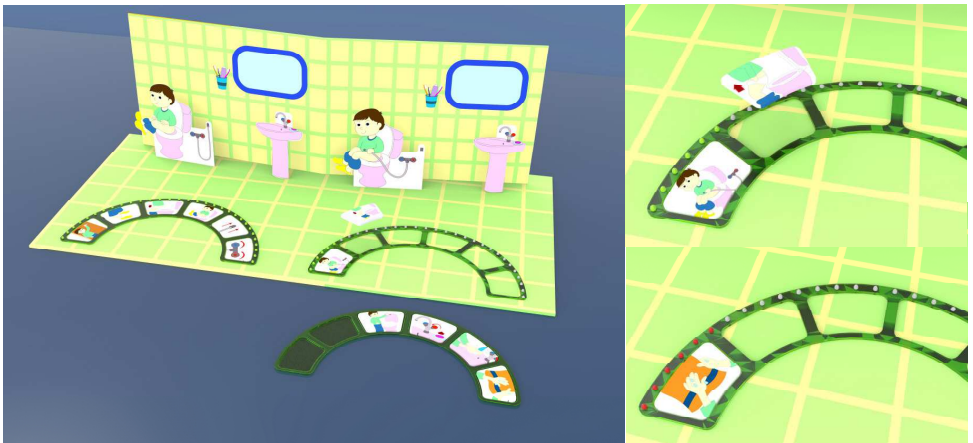

Fig. 3 – The popup interactive book with the specific puzzle related to the daily activities.

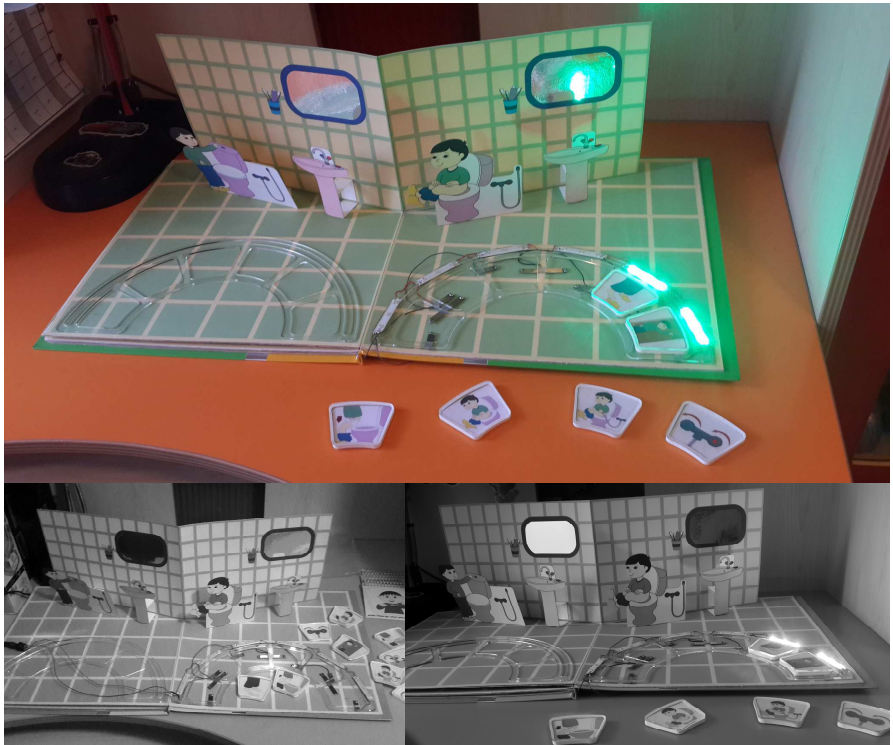

Fig. 4 – The correct placement of cards illuminates the green light for confirmation and the wrong placement results the red lights.

## 5. Conclusion

This product must be learnt by autistic children and they need to exercise it many times. This education can get through signs that confirm his/her activity. With the colorful lights and musical alarm the autistic children encourage to carry out the daily activities in a correct order.

The activity must be repeated over and over again until for he/she it became routine. After the second stage of card recognition, children learn to recognize and remember the order and it is also possible to work on the speed of doing that. This game is under testing for two specialized school for autistic children and the future results can be described in another research. En conclusion it is important to highlight the important impact of color on the learning process of autistic children.

## Bibliography

- [1] Wing, Lo., "The continuum of autistic characteristics." In E. Schopler and G. Mesibov (Eds) Diagnosis and Assessment in Autism. New York: Plenum Press, 1989.
- [ ] American Psychological Association. "Diagnostic and statistical manual of mental disorders" (4th ed.). Washington, DC: APA. 1994.

- [3] Bourque, N. Ashley. "A Comparison of Morphophonetic Faces and the Picture Exchange Communication system on the Production of Verbal Communication in Preschoolers with Autism". (thesis prepared for the degree of master of arts, Louisiana state university), 2008.
- [4] Centre of control and prevention, Iran, 2007.
- [5] Samadi A., McConkey R.. "Autism Spectrum Disorder" .Tehran.2011.
- [6] Tager-Flusberg, H., Paul, R., & Lord, C. , "Language and communication in autism". In F. R. Volkmar, R. Paul, A. Klin, & D. Cohen (Eds.), "Handbook of autism and pervasive developmental disorders" (3rd ed., Vol. 1. Diagnosis, development, neurobiology, and behavior, pp. 335 –364). Hoboken, NJ: Wiley, 2005.
- [7] Siniscalco A., Musante F., Rossi M., "Apparecchi d'illuminazione per luce colorata e loro misura", SIOF-Color conference, Palermo, Ottobre 2009.
- [8] Blattner P., "Characterization of Imaging Luminance Measurement Devices (ILMDs)", R2-29 report, Swiss Federal Office of Metrology and Accreditation METAS, 2003.
- [9] Debevec P.E., Malik J., "Recovering High Dynamic Range Radiance Maps from Photographs, Computer Graphics", (Proc. Siggraph 97), ACM Press, pp. 369-378, New York, 1997.
- [10] Nikopoulos Ch., Keenan M, Mickey. "Effect of video modeling. training and Generalization if social in tation and Reipractal play by children with autism", European Journal of behavior analysis volume, 2004.
- [11] Kissinger L., David W. , "Using the Harp as Communication Channel with Children with Autism" International of Special Education vol 23 n 3, 2008.
- [12] Billard A., Robins B., Nadel J., Dautenhahn K. , "Building Robot a Mini humanoid Robot for the rehailoitation of Children with Autism", Technology Journal , 2006.
- [13] Mirenda P., "Toward functional augmentative and alternative communication for students with autism": Manual signs, graphic symbols, and voice output communication aids. Language, Speech, and Hearing Services in Schools, 34, 203 –216, 2003.
- [14] Acheson M., "The Effect of Natural Aided Language Stimulation on Requesting Desired Objects or Actions in Children with Autism Spectrum Disorder", (doctoral dissertation, University of Cincinnati), 2006.
- [15] Grandin T., "Thinking in Pictures : And Other Reports from My Life with Autism". New York: Bantam Dell Publishing Group , 1995.
- [16] Bonnel, A., Mottron, L., Peretz, I., Trudel, M., Gallun, E. & Bonnel, A.M. "Enhanced pitch sensitivity in individuals with autism: A signal detection analysis". Journal of Cognitive Neuroscience, 15, 226-235, 2003.
- [17] Heaton, P., Hermelin, B. & Pring, L. "Autism and pitch processing: A precursor for savant musical ability?" Music perception, 15, 291-305, 1998.
- [18] Mottron, L., Peretz, I. & Ménard, E. "Local and global processing of music in high-functioning persons with autism: Beyond central coherence?" Journal of Child Psychology and Psychiatry, 41, 1057-1065. Color Autism 29, 2000.
- [19] Caron, M.J., Mottron, L., Rainville, C. & Chouinard, S. "Do high functioning persons with autism present superior spatial abilities?" Neuropsychologia, 42, 467-481. 2004.
- [ 0] Mitchell, P. & Ropar, D. "Visuo-spatial abilities in autism: A review. Infant and Child Development", 13, 185-198, 2004.
- [ 1] Plaisted, K., O'Riordan, M. & Baron-Cohen, S. , "Enhanced visual search for a conjunctive target in autism: A research note". Journal of Child Psychology and Psychiatry, 39, 777-783, 1998a.
- [ ] Plaisted, K., O'Riordan, M. & Baron-Cohen, S., "Enhanced discrimination of novel, highly similar stimuli by adults with autism during a perceptual learning task". Journal of Child Psychology and Psychiatry, 39, 765-775. 1998b.
- [ 3] Mottron, L. & Burack, J., "Enhanced perceptual functioning in the development of autism". In J.A. Burack, T. Charman, N. Yirmiya, & P.R. Zelazo (Eds.), The development of autism: Perspectives from theory and research (pp.131-148). Mahwah, NJ: Erlbaum. 2001.
- [ 4] Mottron, L., Dawson, M., Soulières, I., Hubert, B., Burack, J., "Enhanced perceptual functioning in Autism: An update, and eight principles of autistic perception". Journal of Autism and Developmental Disorders, 36, 1573 – 3432. 2006.
- [ 5] Mottron, L., Belleville, S. & Ménard, E., "Local bias in autistic subjects as evidenced by graphic tasks: Perceptual hierarchization or working memory deficit". Journal of Child Psychology and Psychiatry, 40, 743-755, 1999.
- [ 6] Spencer, J., O'Brien, J., Riggs, K., Braddick, O., Atkinson, J. and Wattam-Bell, J., "Motion processing in autism: Evidence for a dorsal stream deficiency". Neuroreport, 11, 2765-2767, 2000.

- [ 7] Milne, E., Swettenham, J., Hansen, P., Campbell, R., Jeffries, H. & Plaisted, K., "High motion coherence thresholds in children with autism". *Journal of Child Psychology and Psychiatry*, 43, 255-263, 2002.
- [ 8] Bertone, A., Mottron, L., Jelenic, P. & Faubert, J. , "Motion perception in autism: A "complex" issue. *Journal of Cognitive Neuroscience*", 15, 218-225. 2003.
- [ 9] Bertone, A., Mottron, L., Jelenic, P. & Faubert, J., "Enhanced and diminished visuo-spatial information processing in autism depends on stimulus complexity", *Brain*, 128, 2430-2441. 2005.
- [30] Franklin, A., Sowden, P., Burley, R., Notman, L. & Alder, "E. Colour perception in children with autism". *Journal of Autism and Developmental Disorders*, 38, 1837-47, 2008.
- [31] Kovattana, P.M. & Kraemer, H.C., "Response to multiple visual cues of color, size and form by autistic children". *Journal of Autism and Childhood Schizophrenia*, 4, 251-261, 1974.
- [32] Ungerer, J.A. & Sigman, M., "Categorization skills and receptive language development in autistic children". *Journal of Autism and Developmental Disorders*, 17, 3-15, 1987.
- [33] Brian, J.A., Tipper, S.P., Weaver, B. & Bryson, S.E., "Inhibitory mechanisms in autism spectrum disorders: typical selective inhibition of location versus facilitated perceptual processing". *Journal of Child Psychology and Psychiatry*, 44, 552-560, 2003.