



# A computational Model to Assess the Contribution of Growth Factors to Phenotype Stability in Chondrocytes

J. Kerkhofs<sup>1,2,3</sup>, H. Van Oosterwyck<sup>1,2</sup>, L. Geris<sup>1,3</sup>

<sup>1</sup>Prometheus, Division of Skeletal Tissue Engineering; <sup>2</sup>Biomechanics section, KU Leuven; <sup>3</sup>Biomechanics Research Unit, U.Liège, Belgium

KU LEUVEN

Université de Liège



## INTRODUCTION

### Background

- Developmental engineering: an in vivo-like in vitro process to engineer tissues<sup>1</sup>
- Understanding of combination and interplay of signals directing chondrocyte development is required

### Growth plate regulation

- BMP, Wnt, FGF, Ihh/PTHrP, TGFβ and IGF-I are important paracrine signals
- Sox9 is the master regulator of chondrogenesis
- Runx2 controls chondrocyte hypertrophy

### Modelling

- Multiple cross-talks turn linear signalling cascades into a complex network
- Models can assist in interpretation and evaluation of qualitative network behaviour

## MATERIALS & METHODS

- A literature-based network comprising several influences on the balance between Sox9 and Runx2

- Wnt
- BMP
- FGF
- Ihh/PTHrP
- IGF-I
- TGF β

- 46 nodes and 161 interactions
- ODE simulation using additive functions
- The stable state is equated with a cell type, i.e. a proliferative chondrocyte in the case of a Sox9-positive state and a hypertrophic chondrocyte in the case of a Runx2-positive state

Figure 1: The chondrocyte gene network

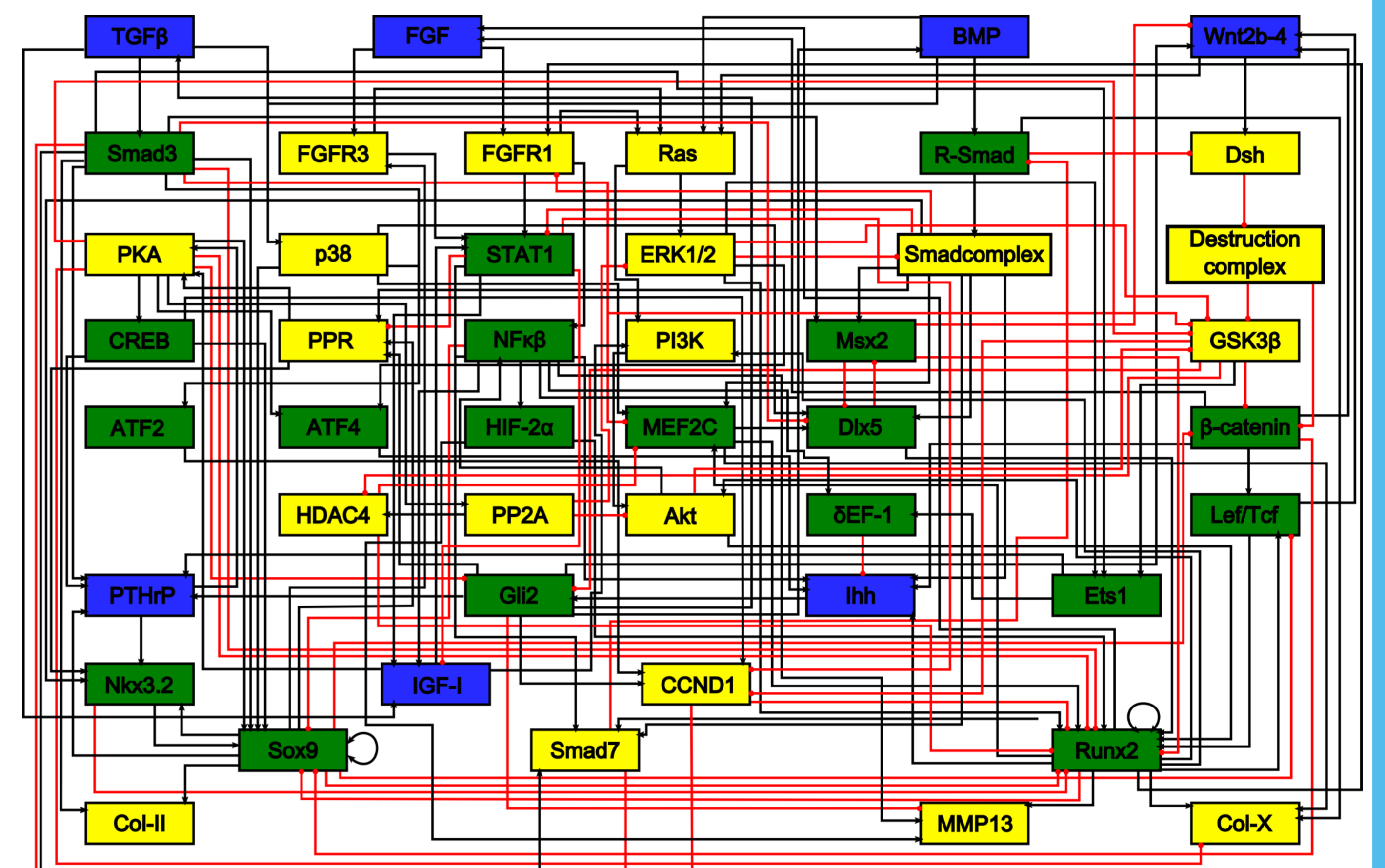

## PHENOTYPICAL STABILITY

- Stability to perturbation in a random node
- Shows higher stability of Runx2 state

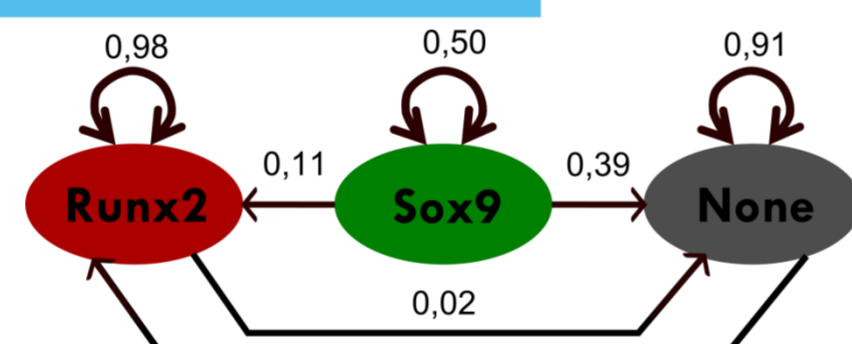

Figure 2: 3 stable states (cell types) and their transition likelihoods

## HYPERTROPHIC SWITCH

- Upregulation of Smad-1-5-8 is the most efficient way of achieving hypertrophy

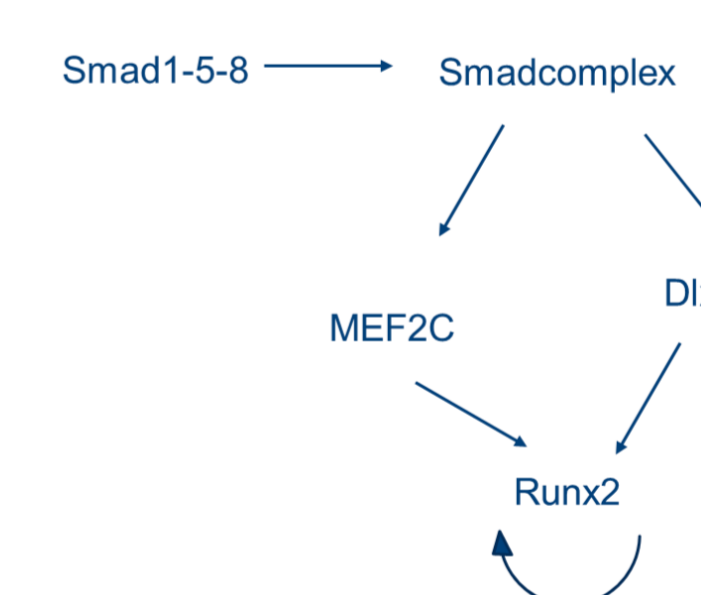

Figure 4: Main mechanism of hypertrophic switch

- Outcome is dependent on dose

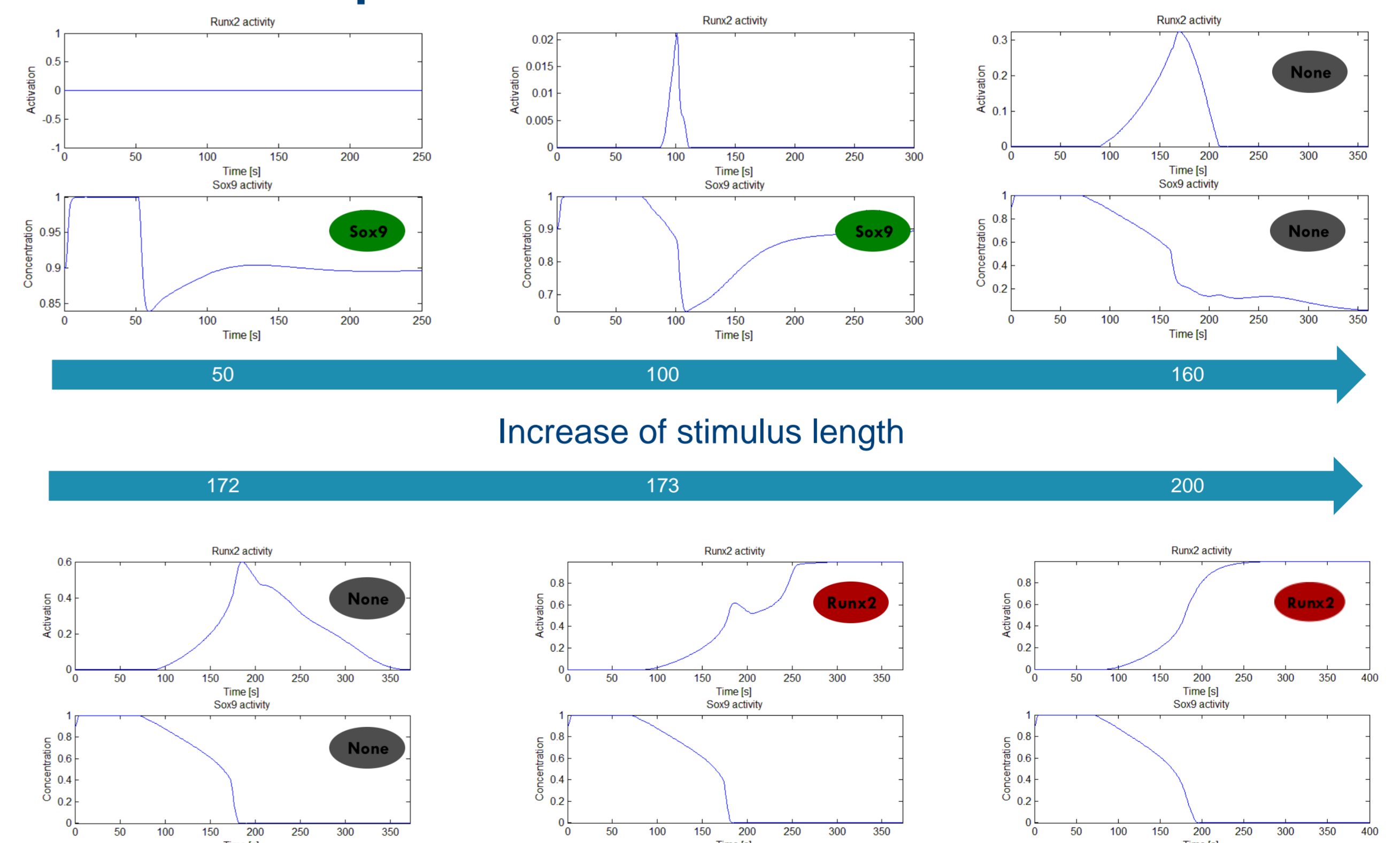

Figure 5: The influence of Smad1-5-8 activation on cell fate depends on the stimulus size

## STABILITY OF CARTILAGE

- What is the contribution of individual 'maintenance' factors?

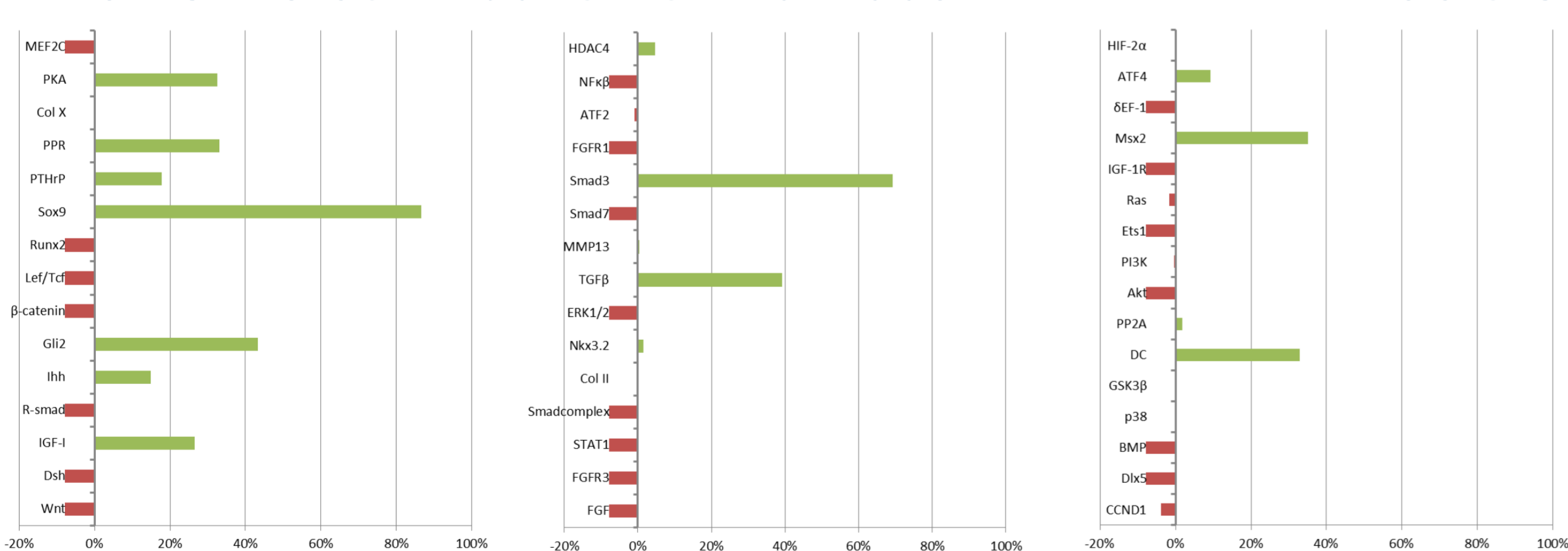

Figure 3: Green bars indicate a positive effect on stability, red bars indicate a detrimental effect

## DISCUSSION

- Analysis based on topological information reveals the dominating players in the subsequent stages of endochondral ossification
- Approach can be used to monitor and instruct the formation of cellular constructs containing chondrocytes

## CONTACT DETAILS & REFERENCES

[1] Lenas P. et al. (2009) *Tissue Eng Part B Rev*, 15, 381.

Liesbet Geris, University of Liège & KU Leuven, Belgium  
Liesbet.geris@ulg.ac.be