

Capture of 3D sound with a spherical microphone array

Hermine Feron (Deltatec)

Jean-Jacques Embrechts (University of Liège, Intelsig research group)

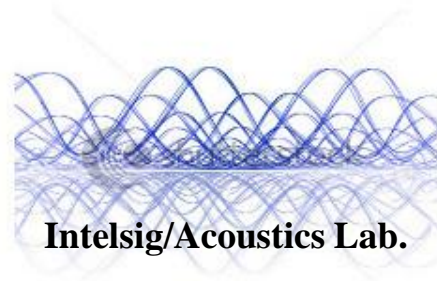
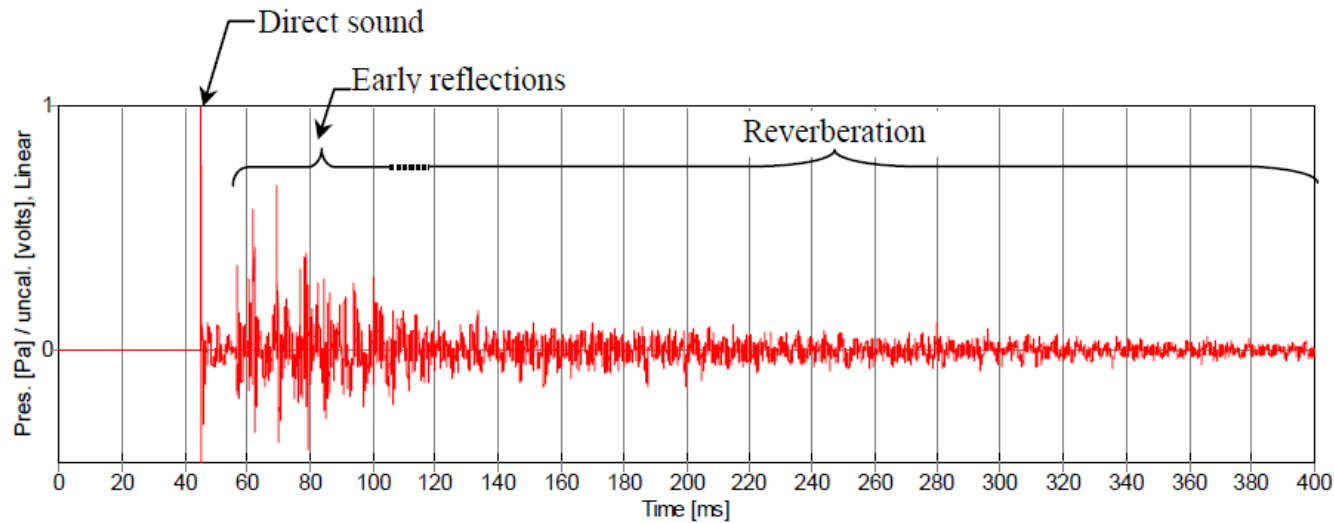

TABLE OF CONTENTS

- Context
- Microphone arrays
 - Applications
 - Geometry
 - Beamforming
- Designed array
- Results
- Conclusion and prospects

CONTEXT

- Master's thesis in the field of architectural acoustics at the University of Liege
- Objective : Extract 3D Room Impulse Responses with a spherical microphone array



MICROPHONE ARRAYS

- They consist of
 - An arrangement of two or several microphones: *geometry*
 - A linear combination of the signals measured by the microphones: *beamforming*

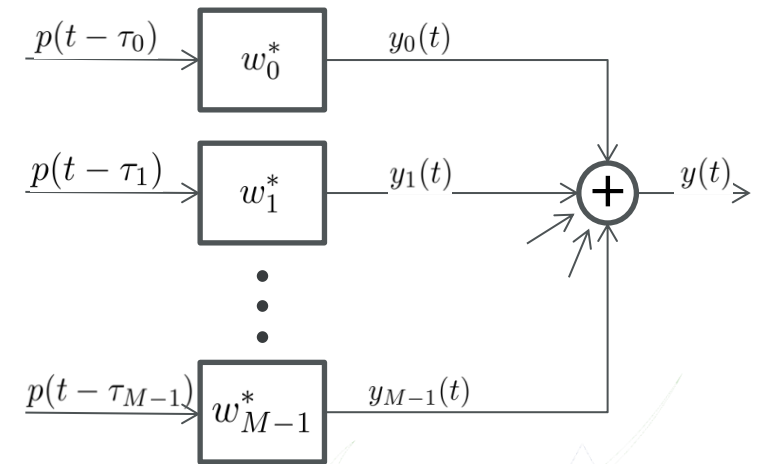
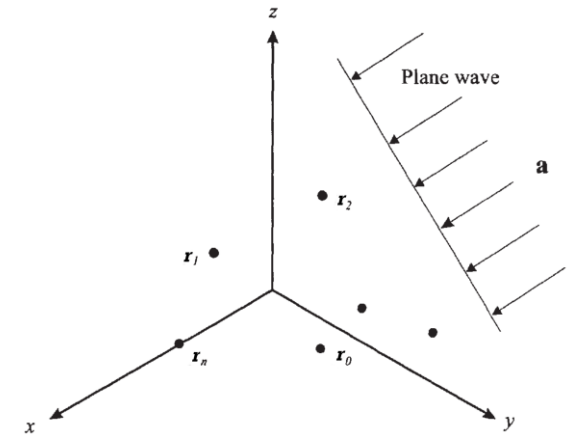

MICROPHONE ARRAYS

- Microphone Array = Geometry + Beamforming
- A microphone array can act like a highly directional microphone by combining the measured signals.
- The main response axis of the beam can be steered in the space thanks to post treatment (electronic steering)

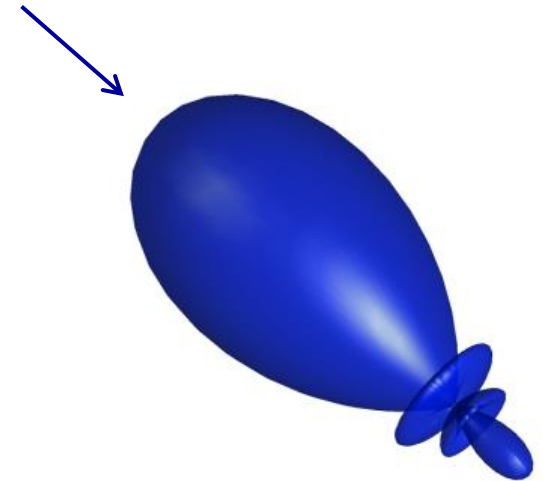
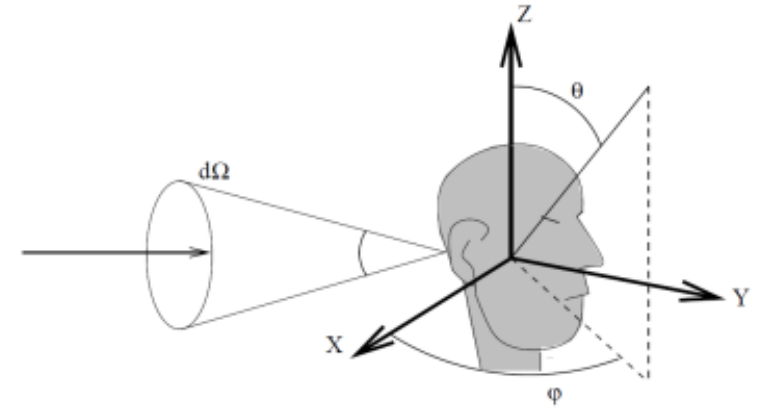

Beam pattern of array output

MICROPHONE ARRAYS : Applications

- Three main uses:
 - Extract a particular signal from ambient noise (ex : telephone, conference)
 - Multichannel reproduction based on 3D sound field recording
 - Extract acoustic source localisation: the beam is steered in every direction to examine the room and to localize the sound.

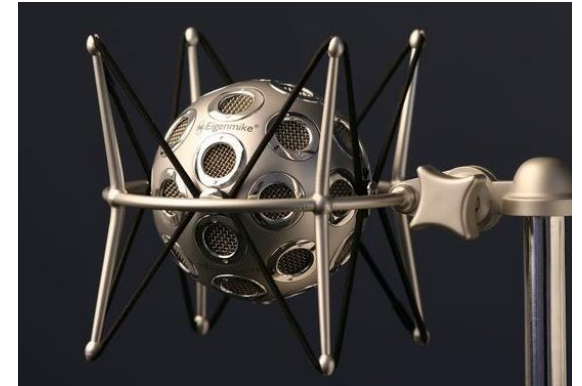

MULTIPLE GEOMETRIES

Linear

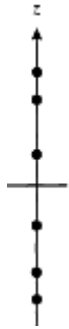

Planar

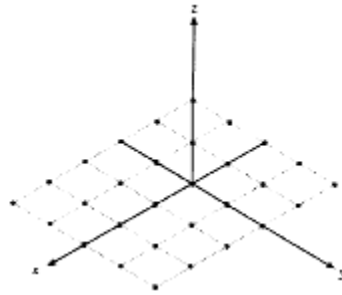

Volumetric

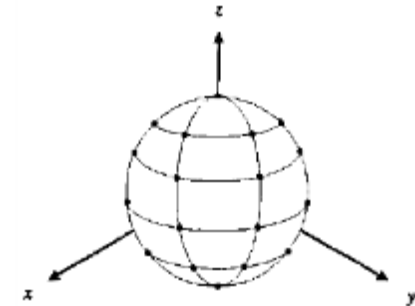
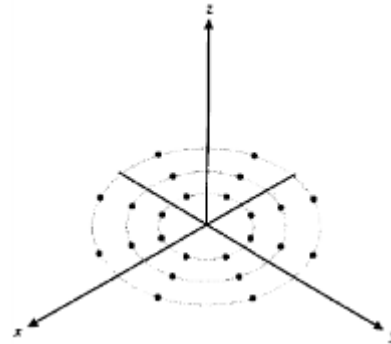
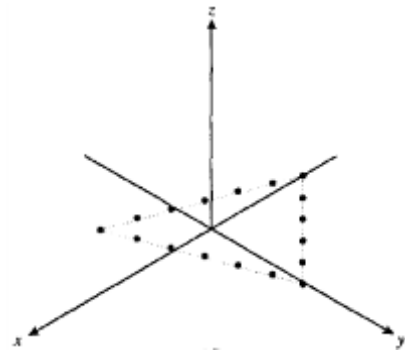
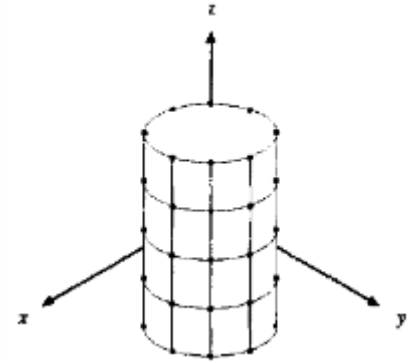

BEAMFORMING

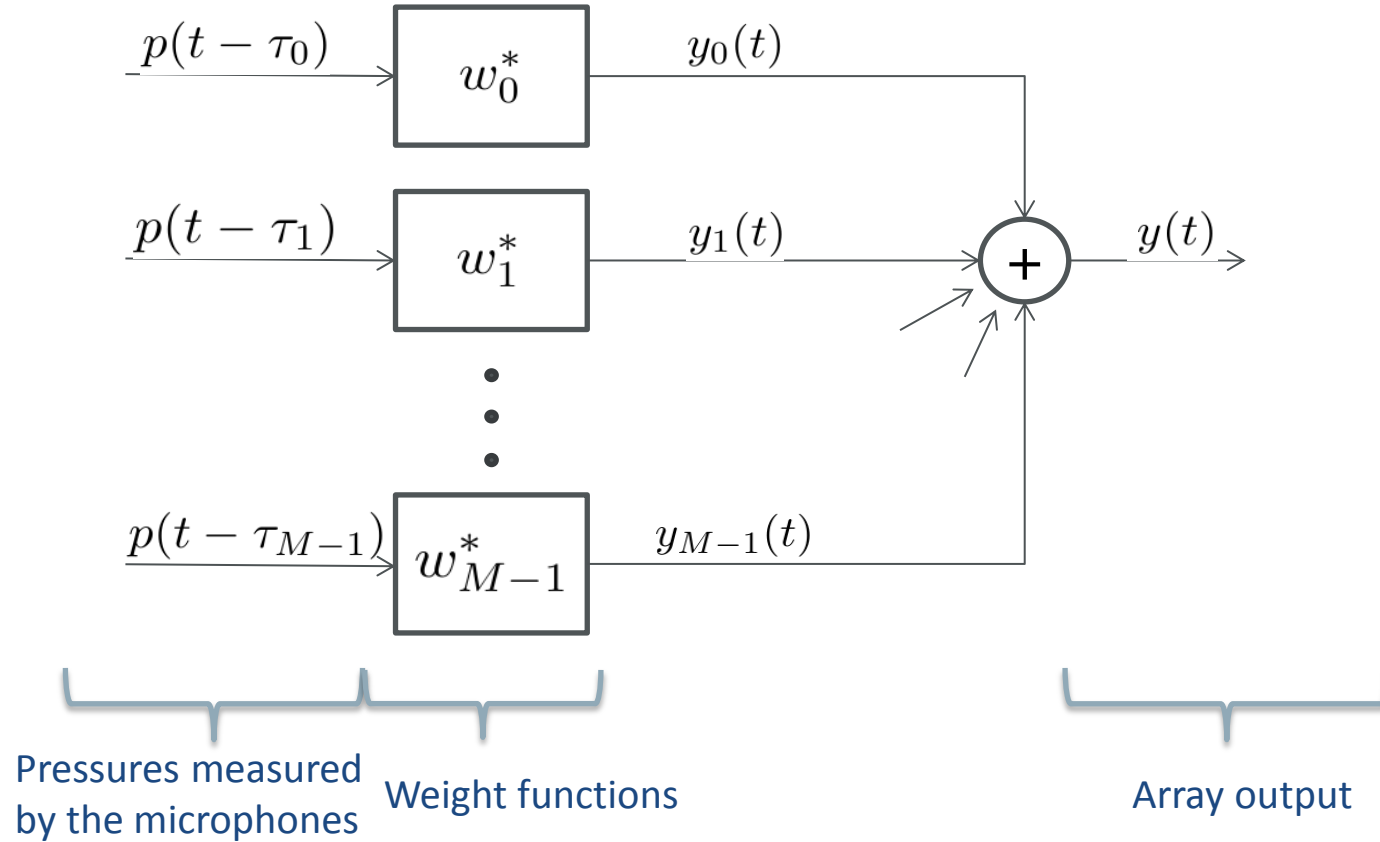

$$Y(\omega) = \sum_{j=0}^{M-1} W^*(\omega, \Omega_j) P(\omega, \Omega_j)$$

Frequency domain

$$= \sum_{n=0}^N \sum_{m=-n}^n W_{nm}^*(\omega) P_{nm}(\omega)$$

Spherical harmonics domain

MICROPHONE ARRAY DESIGNED

- Spherical microphone array with a 10 cm radius (“rigid” sphere).
- 16 omnidirectional microphones are distributed nearly uniformly on the surface of the sphere.
- 2 sound cards, each with 8 inputs.
- Multichannel recordings in .wav format.
- Post-signal processing with Matlab[®].



TEST 1 : Equipment

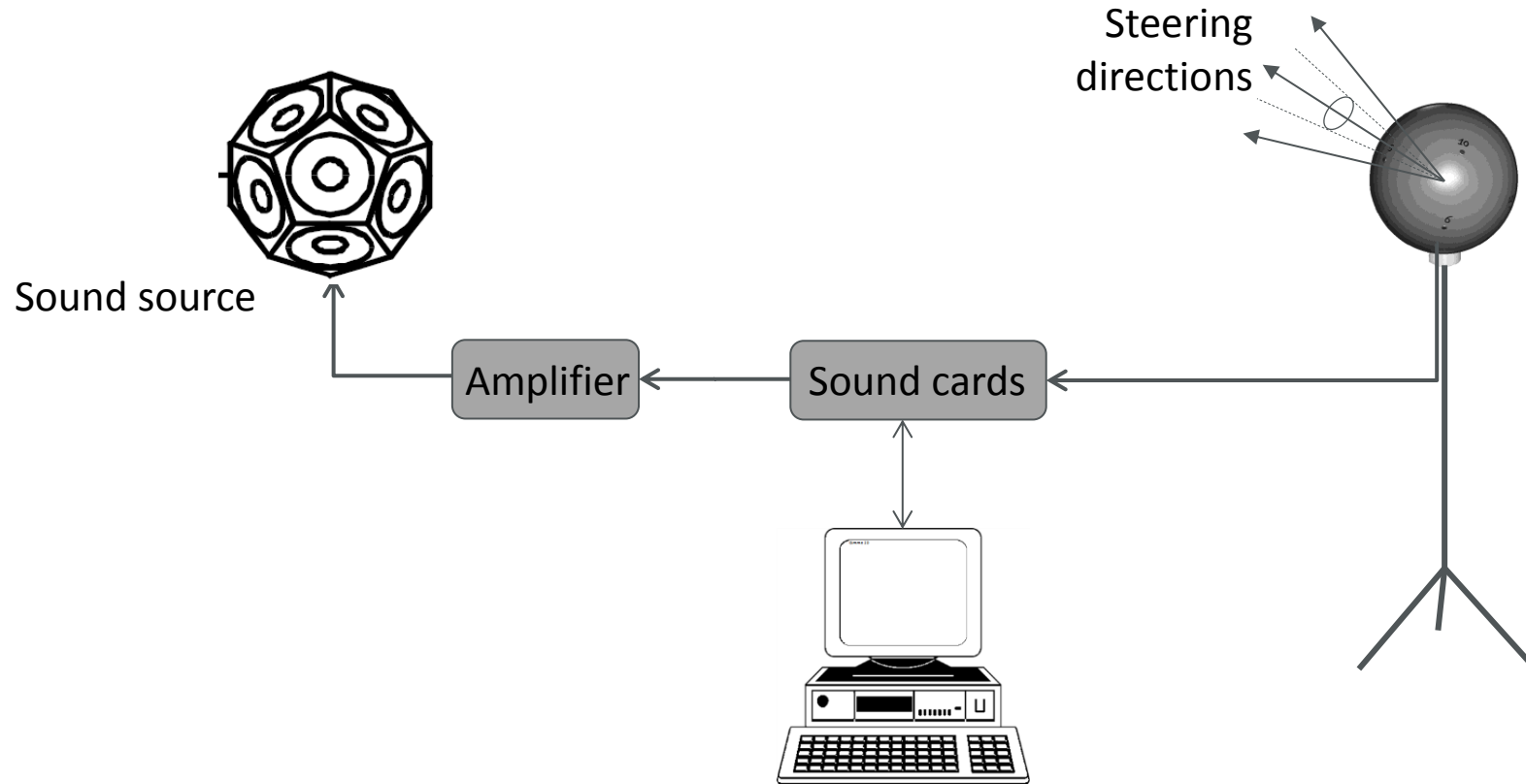

Different steering directions are defined during post-processing.

TEST 1 : Measurement Setup

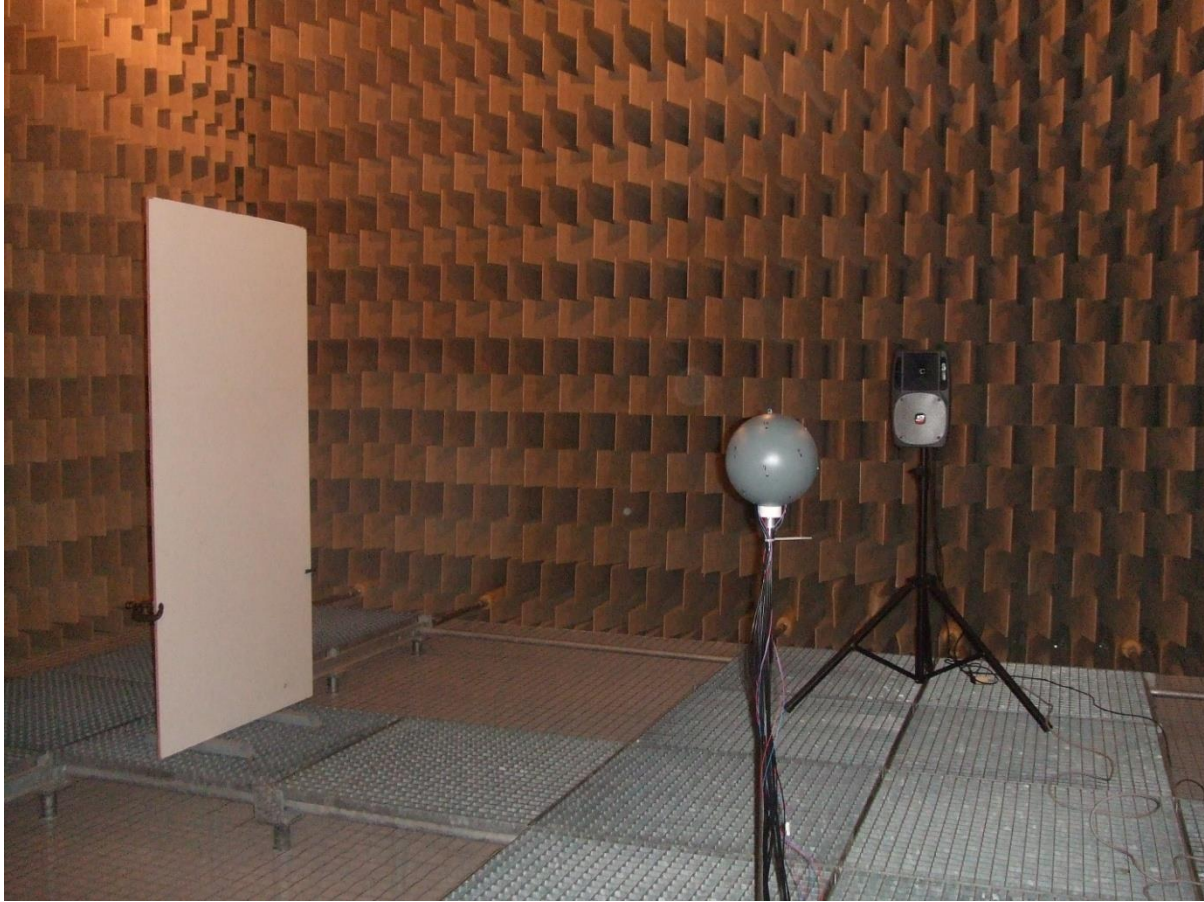
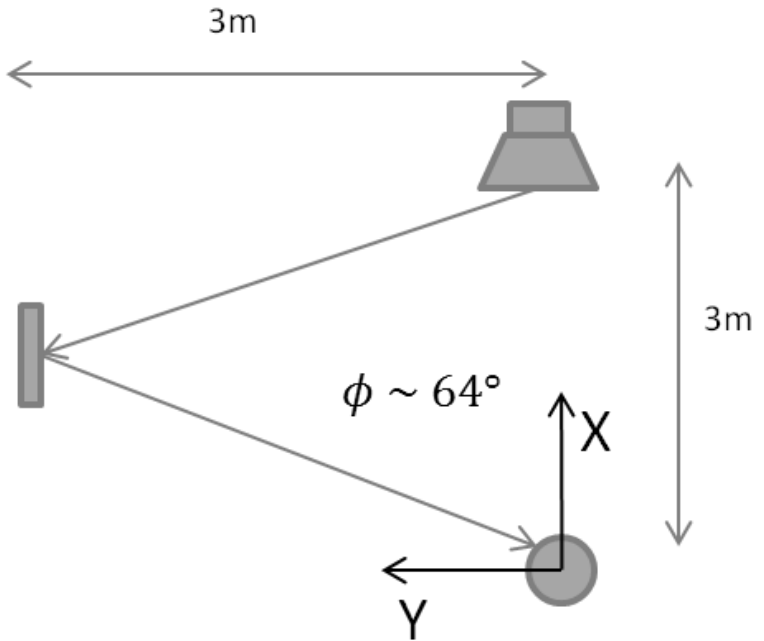

TEST 1 : Analysis of results

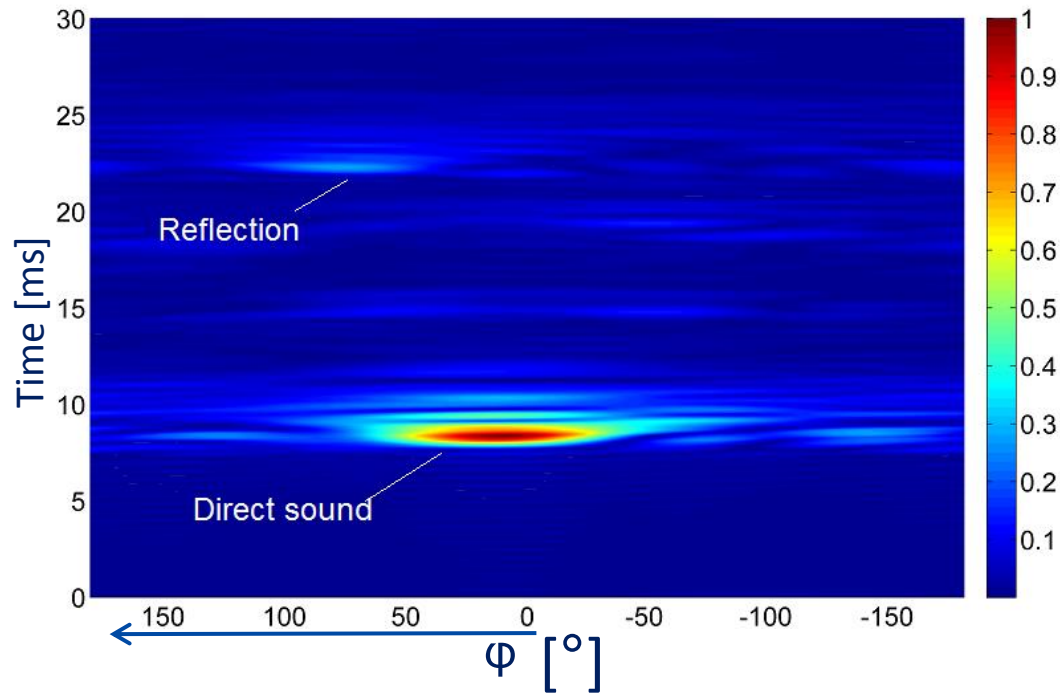

Time evolution of array output
in horizontal plane

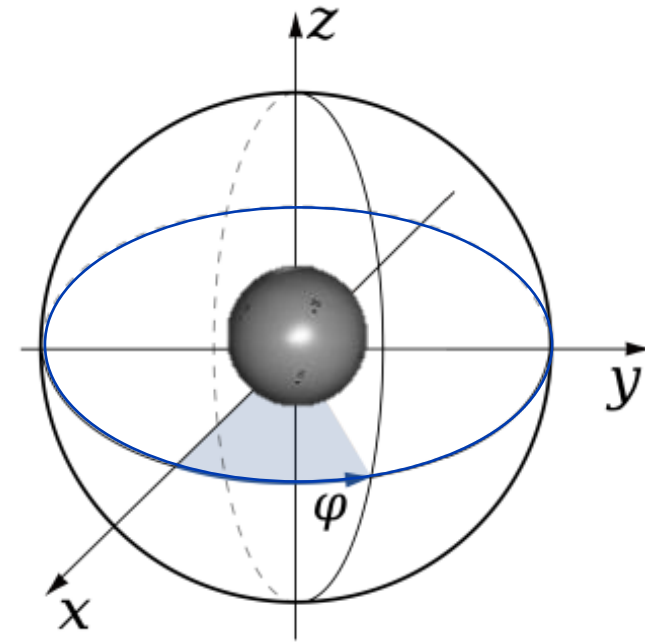

Spherical coordinates

TEST 1 : Analysis of results

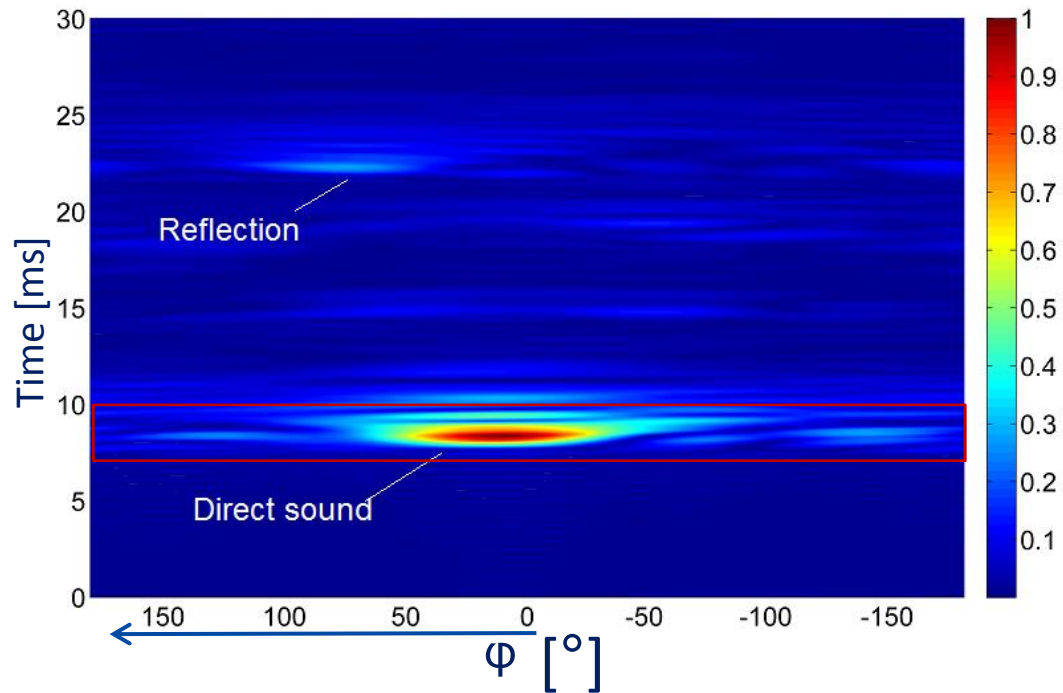

Time evolution of array output
in horizontal plane

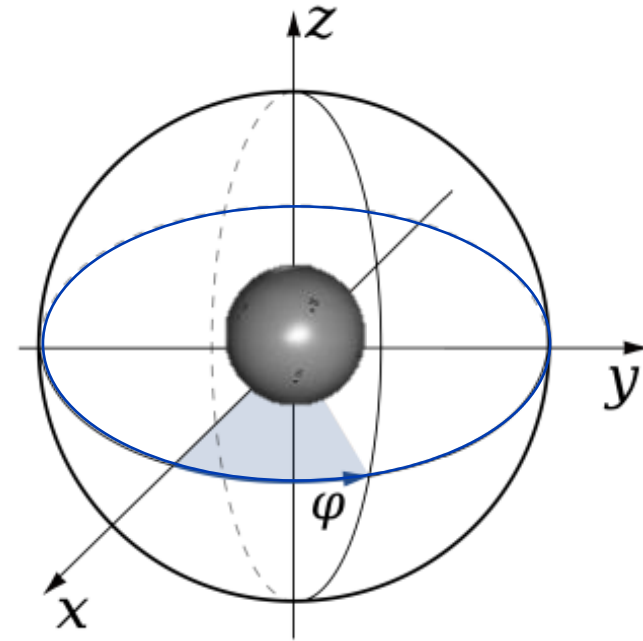

Spherical coordinates

TEST 1 : Analysis of results

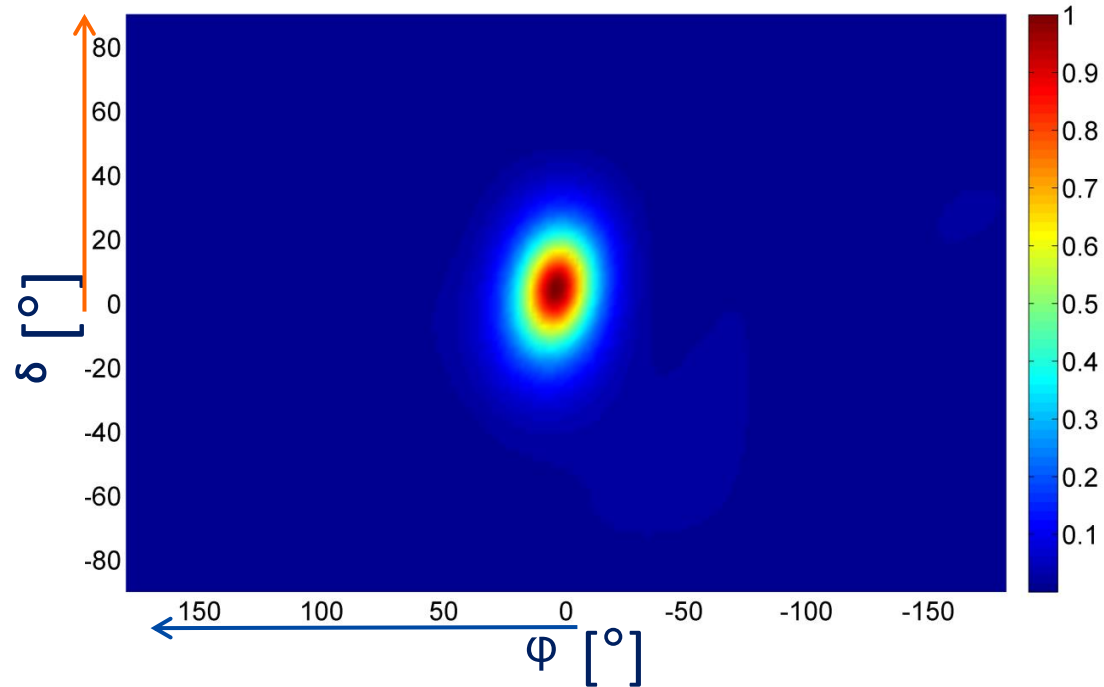

Space distribution of array output at a certain time

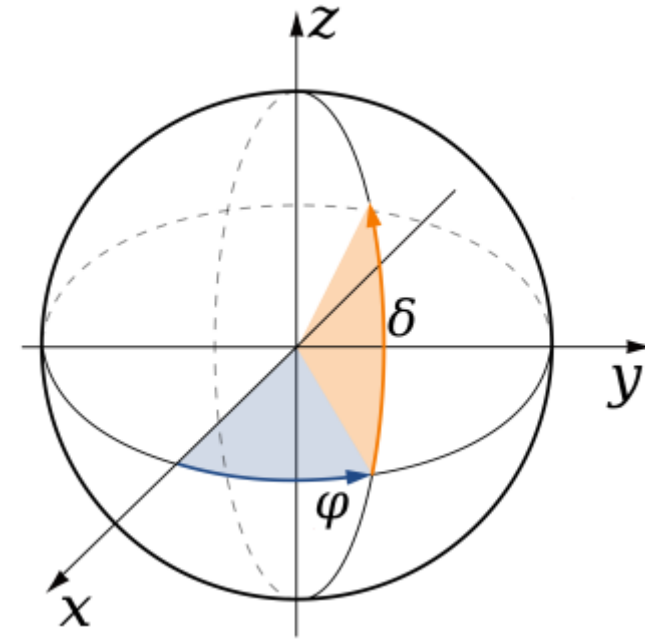

Spherical coordinates

TEST 1 : Analysis of results

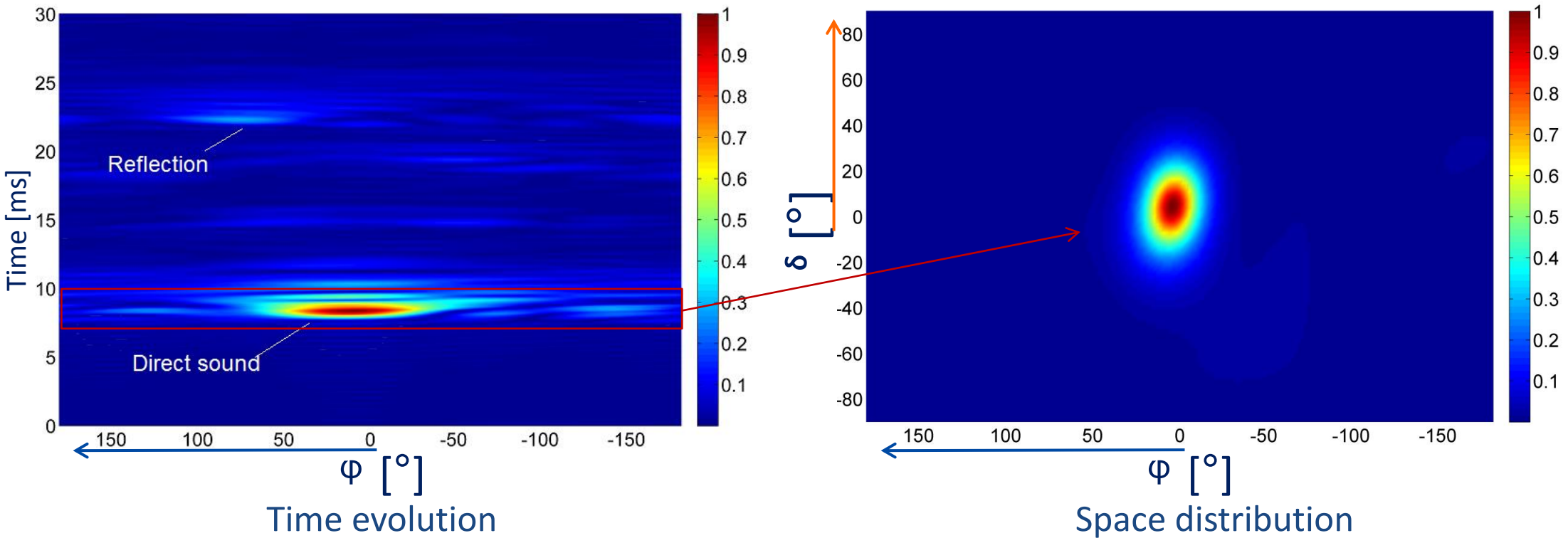

➔ Localization of sound source in time and space

TEST 2 : Directional impulse responses in a cubic room

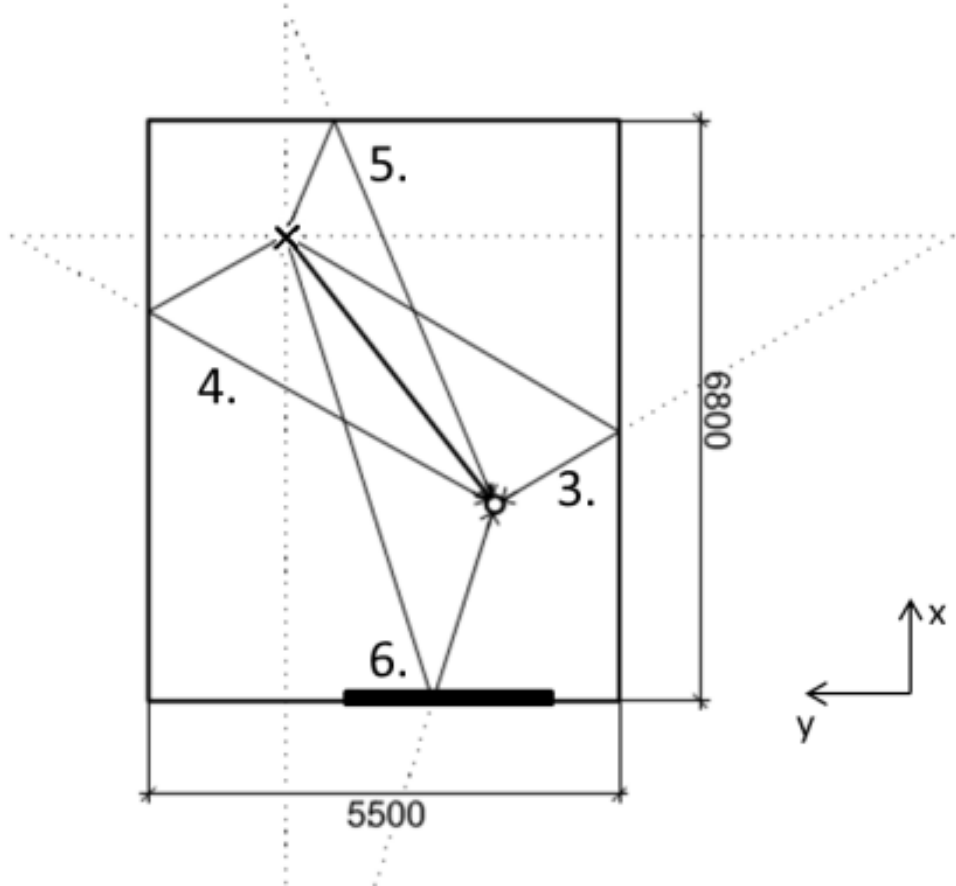

TEST 2 : Directional impulse responses in a cubic room

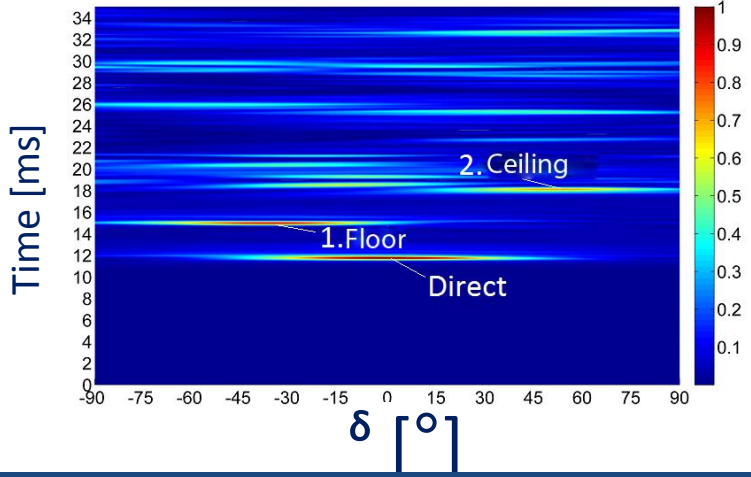
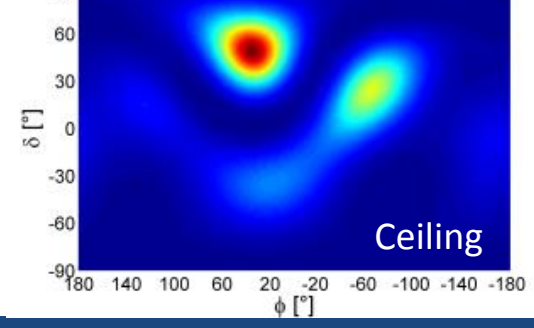
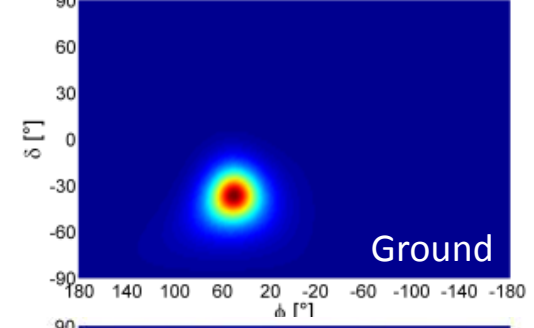
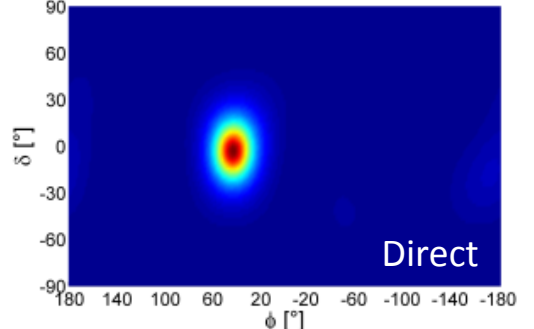
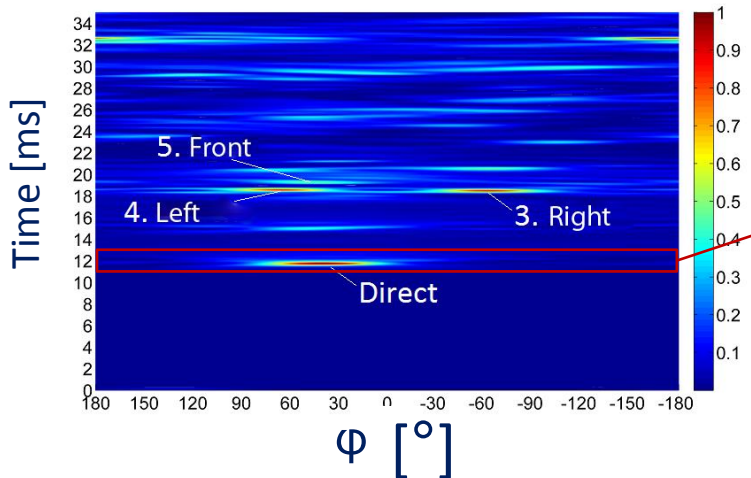

TEST 2 : Directional impulse responses in a cubic room

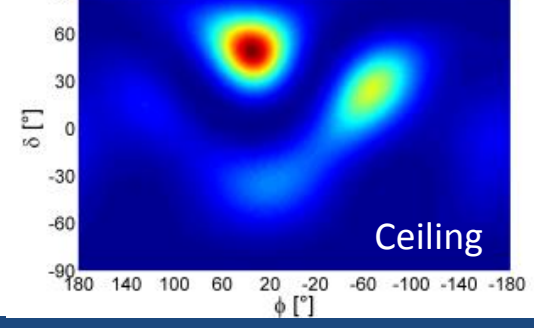
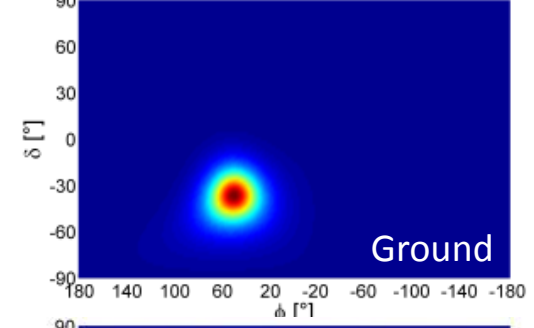
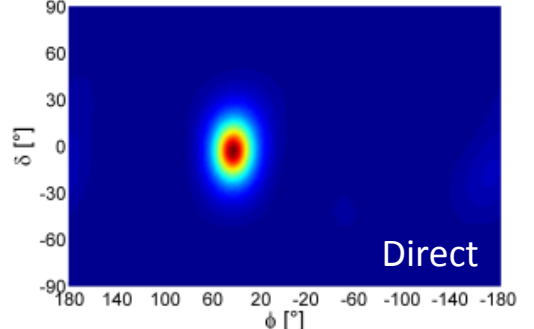
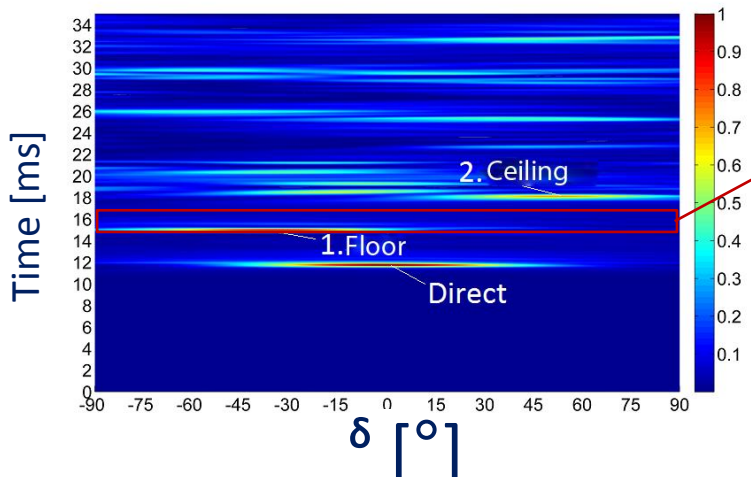
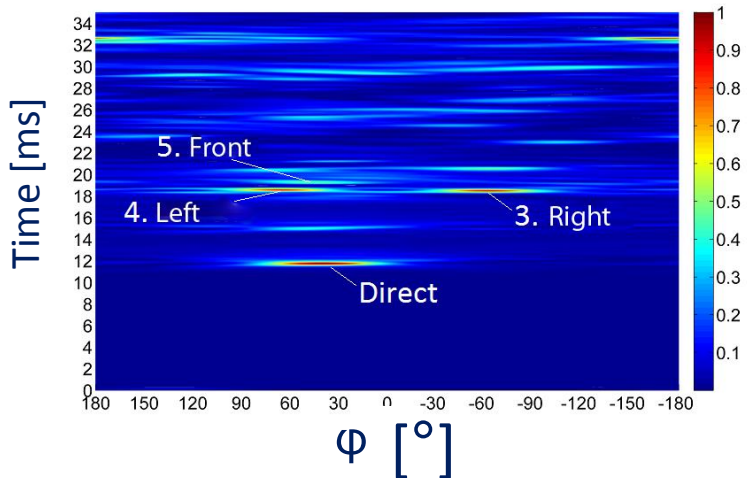

TEST 2 : Directional impulse responses in a cubic room

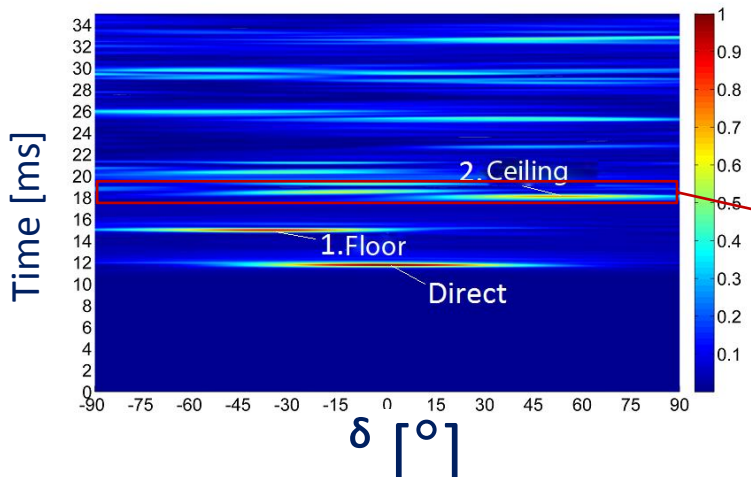
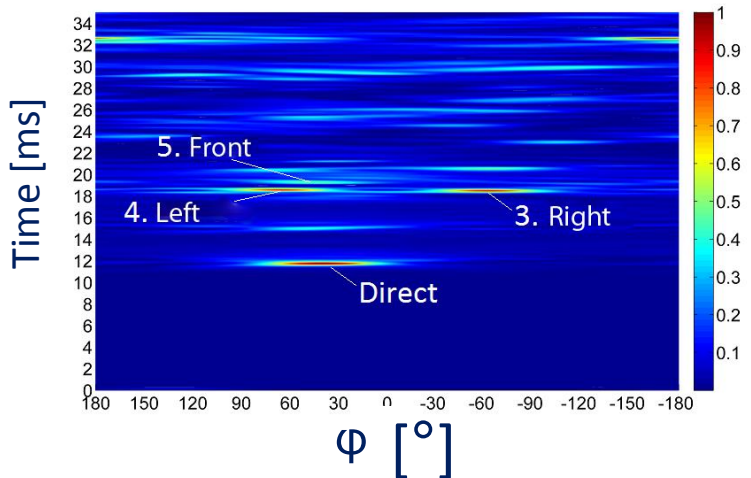

17 to 18,2 ms

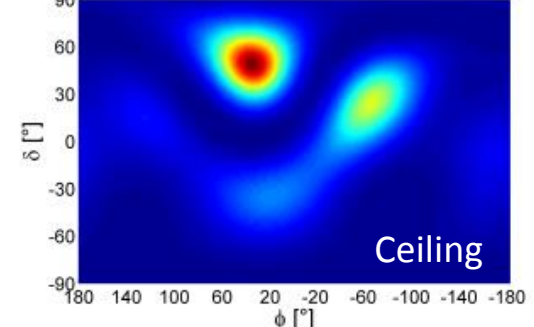
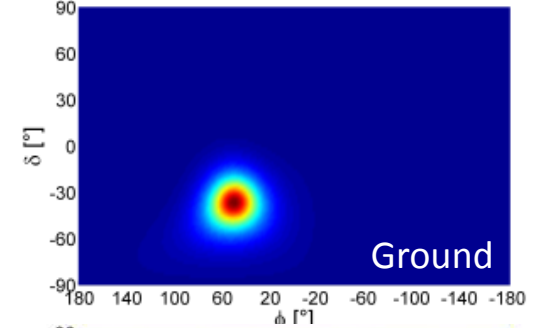
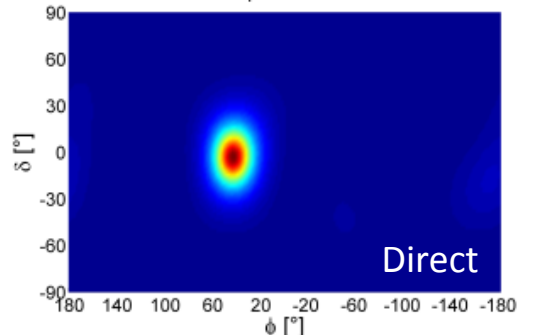

CONCLUSION AND PROSPECTS

- This tool allows
 - to get directional information about rooms
 - to localize individual sound waves in the temporal and spatial domain
- The final outcome of this project: to create a practical tool for acousticians
- The array can be used for other applications
 - 3D recording and multichannel reproduction (Master project 2014)

ACKNOWLEDGEMENTS

