



Istituto Universitario
di Studi Superiori



Università degli
Studi di Pavia

**EUROPEAN SCHOOL FOR ADVANCED STUDIES IN
REDUCTION OF SEISMIC RISK**

ROSESCHOOL

**ANALYSIS OF CODE PROCEDURES FOR SEISMIC
ASSESSMENT OF EXISTING BUILDINGS:
ITALIAN SEISMIC CODE, EC8, ATC-40, FEMA356, FEMA440**

**An Individual Study Submitted in Partial
Fulfillment of the Requirements for the PhD Degree in**

EARTHQUAKE ENGINEERING

By

BOYAN MAHAYLOV

Supervisor: Dr. LORENZA PETRINI

April 2006

The Individual Study entitled, “Analysis of Code Procedures for Assessment of Existing Buildings: Italian Seismic Code, EC8, ATC-40, FEMA356, FEMA440”, by Boyan Mihaylov, has been approved in partial fulfillment of the requirements for the Doctor of Philosophy Degree in Earthquake Engineering.

Lorenza Petrini_____

Gian Michele Calvi_____

ABSTRACT

It is widely recognized that ground shaking may induce unacceptable levels of damage in existing buildings located in seismic regions. This vulnerability has been attributed to several reasons, such as insufficient strength and stiffness, poor detailing, irregularities in plan and elevation, domination of brittle failure modes over ductile ones, etc. On account of that, seismic assessment of existing buildings is adopted as a problem which needs specific treatment in building codes.

The present study analyzes five codes for assessment of existing buildings: the Italian seismic code, EC8, FEMA356, ATC-40 and FEMA440. The analysis of each code is performed within a common theoretical frame. The code assumptions and simplifications are pointed out together with their possible inconsistencies and weaknesses. Comparisons between the different procedures are performed as well. The most important outcomes stress insufficiencies in the analysis procedures as well as in the criteria for choice of model dimension and analysis type, consideration of dynamic P- Δ effects, in non-linear modeling, shear resistance evaluation, and application of force-based procedures.

ACKNOWLEDGEMENTS

I would like to thank Dr. Lorenza Petrini for her kind assistance and precious advices during all the stages of this work.

TABLE OF CONTENTS

ABSTRACT	I
ACKNOWLEDGEMENTS	II
TABLE OF CONTENTS.....	III
LIST OF FIGURES	V
LIST OF TABLES.....	VII
1. INTRODUCTION	1
2. PERFORMANCE LEVELS AND PERFORMANCE OBJECTIVES	2
2.1 Building performance levels.....	2
2.2 Rehabilitation objectives	4
3. KNOWLEDGE LEVELS	6
4. STRUCTURAL MODELING AND ANALYSIS PROCEDURES.....	8
4.1 Analysis procedures.....	8
4.1.1 Displacement-based analysis procedures	8
4.1.1.1 Linear static procedure	8
4.1.1.2 Linear dynamic procedure.....	10
4.1.1.3 Nonlinear dynamic procedure	11
4.1.2 Force-based linear procedures- Italian seismic code and EC8.....	11
4.2 2D versus 3D models.....	11
4.3 Choice of analysis procedure.....	14
4.4 P- Δ effects.....	16
4.5 Horizontal torsion.....	18
4.6 Multidirectional effects.....	20
4.7 Summary.....	22
5. NON-LINEAR STATIC PROCEDURE	25
5.1 Non-linear modeling.....	25
5.2 Load vectors	32

5.3 Solution of SDOF systems.....	34
5.4 Solution of MDOF systems	48
6. ACCEPTANCE CRITERIA.....	53
6.1 Primary and secondary components	53
6.2 Deformation-controlled and force-controlled actions.....	54
6.3 Deformation limits and force capacities values	55
6.4 Displacement-based analysis procedures.....	55
6.4.1 Linear analysis procedures	55
6.4.2 Non-linear analysis procedures	62
6.5 Force-based linear procedures- Italian seismic code and EC8	63
7. CONCLUSION.....	64
REFERENCES	66

LIST OF FIGURES

Figure 4.1. Criteria for regular distribution of mass and stiffness in plan acc. to EC8: a) Interpretation of e_{0x} to r_x ratio; b) Limits on e_{0x}/r_x and l_s/r_x ratios	13
Figure 4.2. Static and dynamic P- Δ effects.....	16
Figure 4.3. Amplification of the torsional effects due to strength irregularity	19
Figure 5.1. Typical plastic hinge M - θ relationships: a) beams; b) columns	26
Figure 5.2. Plastic zone length: a) beams; b) columns	27
Figure 5.3. Shear force, carried through concrete mechanisms: a) beams (ACI-318); b) columns	29
Figure 5.4. Typical joint V - γ relationships: a) interior; b) other	31
Figure 5.5. Types of strength degradation: a) Cyclic strength degradation; b) In-cycle strength degradation.....	31
Figure 5.6. Capacity curve: a) bi-linear idealization; b) hysteretic model.....	34
Figure 5.7. Displacement Modification Technique: a) $\delta_{max}=S_d(T_0)$; b) $\delta_{max}=S_d(T_0)C_1$; c) $\delta_{max}=S_d(T_0)C_1C_2$; d) $\delta_{max}=S_d(T_0)C_1C_2C_3$	36
Figure 5.8. Non-linear static procedures: a) DCM acc. to FEMA356; b) CSM acc. to ATC-40; c) CSM acc. to FEMA440	38
Figure 5.9. ATC-40- degradation effects: a) Influence of the quality of the seismic resistance system; b) Influence of the post-yield stiffness ratio α_{max}	40
Figure 5.10. CSM- Solution in ADRS coordinate system.....	41
Figure 5.11. Types of hysteretic behaviour, used for evaluation of FEMA356 DCM and ATC-40 CSM	42
Figure 5.12. Dynamic instability: a) FEMA356 DCM for $T_0=0.6s$; b) ATC-40 CSM.....	43

Figure 5.13. Dynamic stability: a) maximum strength ratio; b) in-cycle degradation stiffness ratio	44
Figure 5.14. Types of hysteretic behaviour, considered by the improved CSM	45
Figure 5.15. Improved CSM- Solution in ADRS coordinate system	46
Figure 5.16. Maximum strength ratio according to FEMA356 and FEMA440	48
Figure 5.17. C_3 coefficient according to FEMA356 and FEMA440	48
Figure 5.18. Imposed displacements analysis and push-over analysis	50
Figure 5.19. Equivalent SDOF system (ESDOF)	50
Figure 6.1. Component force versus deformation curves	54
Figure 6.2. Definition of chord rotation: a) beams; b) columns	57
Figure 6.3. Limiting chord rotations	57
Figure 6.4. Beam under monotonic loading.....	59
Figure 6.5. Beam under cyclic loading	59
Figure 6.6. Simplified calculation of the chord rotations: a) general; b) beams; c) columns...	60
Figure 6.7. Joints strength verification	61
Figure 6.8. Chord rotation variation	62

LIST OF TABLES

Table 2.1 Target building performance levels and ranges	2
Table 2.2 Common target building performance levels.....	3
Table 3.1 Knowledge factors acc. to FEMA356.....	6
Table 3.2 Confidence factors acc. to Italian seismic code.....	7
Table 3.3 Partial safety factors acc. to EC8	7
Table 5.1 Plastic rotations- beams	29
Table 5.2 Plastic rotations- columns.....	30
Table 5.3 Load vectors.....	33
Table 5.4 Structural behaviour types	40

1. INTRODUCTION

It is widely recognized that ground shaking may induce unacceptable levels of damage in existing buildings located in seismic regions. This vulnerability has been attributed to several reasons, such as insufficient strength and stiffness, poor detailing, irregularities in plan and elevation, domination of brittle failure modes over ductile ones, etc. On account of that, seismic assessment of existing buildings is adopted as a problem which needs specific treatment in building codes. Such codes are applied in several countries with high levels of seismic hazard- Japan, New Zealand, USA, etc. In Europe, recommendations are given in Eurocode 8 – Part 3. Code procedures for assessment and strengthening of existing buildings have been recently developed also in Italy.

The objective of the current work is to summarize, interpret, and compare the procedures for seismic assessment of existing buildings according to the Italian Seismic Code, EC8, ATC-40, FEMA 356, and FEMA 440. This work is focused on the problems of performance levels and performance objectives; knowledge levels; analysis procedures; 2D versus 3D modeling; P- Δ effects; horizontal torsion; multidirectional effects; and acceptance criteria. Each of these issues is discussed in the following manner. First, the problem is defined and analyzed with no reference to any particular code. The controlling factors are identified and their effect is presented qualitatively or in terms of general expressions. Second, the code procedures are exposed and interpreted within the above general frame. Last, the procedures are compared and possible critical points are pointed out.

Among the different analysis procedures, emphasis is put on the non-linear static procedure, considered to be a reasonable compromise between the simplistic linear procedures and the most realistic and complex non-linear dynamic procedures. In terms of material and structural types, the work is mainly focused on reinforced concrete frame structures.

2. PERFORMANCE LEVELS AND PERFORMANCE OBJECTIVES

2.1 Building performance levels

Building performance levels or ultimate states are chosen discrete levels of building damage under earthquake excitation.

- *FEMA356*

FEMA356 defines five structural (S-1 to S-5) and four non-structural (N-A to N-D) performance levels (see the first row and first column of Table 2.1), describing qualitatively and quantitatively the damage, associated with each of them. The structural performance levels concern the damage of the vertical and horizontal lateral-force-resisting elements, while the non-structural levels are related to architectural, mechanical and electrical components.

One of the criteria for damage characterization of the vertical lateral-force-resisting elements is the interstorey drift, with the following approximate values for concrete frames:

- Collapse Prevention Structural Performance level (CP SPL)- 4% transient or permanent drift;
- Life Safety SPL- 2% transient and 1% permanent;
- Immediate Occupancy SPL- 1% transient and negligible permanent interstorey drifts.

Any combination of structural and non-structural performance level defines a building performance level (see Table 2.1). Four common building performance levels, named Operational (1-A), Immediate Occupancy (1-B), Life Safety (3-C) and Collapse Prevention (5-E), are described in Table 2.2. They, together with the levels denoted as 2-B, 1-C, etc in Table 2.1, represent the range of possible retrofit goals (target building performance levels). “Not recommended” are the combinations, which involve high structural and low non-structural damage or vice versa.

Table 2.1 Target building performance levels and ranges

Nonstructural Performance Levels	Structural Performance Levels and Ranges					
	S-1 Immediate Occupancy	S-2 Damage Control Range	S-3 Life Safety	S-4 Limited Safety Range	S-5 Collapse Prevention	S-6 Not Considered
N-A Operational	Operational 1-A	2-A	Not recommended	Not recommended	Not recommended	Not recommended
N-B Immediate Occupancy	Immediate Occupancy 1-B	2-B	3-B	Not recommended	Not recommended	Not recommended
N-C Life Safety	1-C	2-C	Life Safety 3-C	4-C	5-C	6-C
N-D Hazards Reduced	Not recommended	2-D	3-D	4-D	5-D	6-D
N-E Not Considered	Not recommended	Not recommended	Not recommended	4-E	Collapse Prevention 5-E	No rehabilitation

Table 2.2 Common target building performance levels

	Target Building Performance Levels			
	Collapse Prevention Level (5-E)	Life Safety Level (3-C)	Immediate Occupancy Level (1-B)	Operational Level (1-A)
Overall Damage	Severe	Moderate	Light	Very Light
General	Little residual stiffness and strength, but load-bearing columns and walls function. Large permanent drifts. Some exits blocked. Infills and unbraced parapets failed or at incipient failure. Building is near collapse.	Some residual strength and stiffness left in all stories. Gravity-load-bearing elements function. No out-of-plane failure of walls or tipping of parapets. Some permanent drift. Damage to partitions. Building may be beyond economical repair.	No permanent drift. Structure substantially retains original strength and stiffness. Minor cracking of facades, partitions, and ceilings as well as structural elements. Elevators can be restarted. Fire protection operable.	No permanent drift. Structure substantially retains original strength and stiffness. Minor cracking of facades, partitions, and ceilings as well as structural elements. All systems important to normal operation are functional.
Nonstructural components	Extensive damage.	Falling hazards mitigated but many architectural, mechanical, and electrical systems are damaged.	Equipment and contents are generally secure, but may not operate due to mechanical failure or lack of utilities.	Negligible damage occurs. Power and other utilities are available, possibly from standby sources.
Comparison with performance intended for buildings designed under the <i>NEHRP Provisions</i>, for the Design Earthquake	Significantly more damage and greater risk.	Somewhat more damage and slightly higher risk.	Less damage and lower risk.	Much less damage and lower risk.

- *Italian seismic code*

The Italian seismic code defines three limit states, related to structural and non-structural damage:

- Collapse Limit State (CO). The structure is heavily damaged. The residual resistance is sufficient to carry gravity loads only. The majority of the non-structural elements are destroyed. The building has significant tilting and cannot sustain further seismic excitations.
- Severe Damage (DS). The structure has undergone significant damaged and resistance reduction. The non-structural elements are damaged, although the partition walls are not collapsed. The structure shows permanent deformations and generally is uneconomic to repair.
- Limited Damage (DL). The structure is only slightly damaged with insignificant plastic deformations. Repair of structural components is not necessary, since their resistance and stiffness are not compromised. The non-structural elements have cracks, but they can be economically repaired. The residual deformations are negligible.

- *EC8*

EC8 defines limit states of Near Collapse (NC), Significant Damage (SD) and Damage Limitation (DL), essentially corresponding to CO, DS, and DL limit states in the Italian seismic code.

• *Comparisons and comments*

The limit states of Collapse (CO), Severe Damage (DS) and Limited Damage (DL) in the Italian seismic code, can be assumed as approximately equivalent to the FEMA356 common building performance levels of Collapse Prevention (CP), Life Safety (LS) and Immediate Occupancy (IO) respectively.

2.2 Rehabilitation objectives

A seismic rehabilitation objective for a given building consists of one or more rehabilitation goals. Each rehabilitation goal represents target building performance level for given earthquake hazard level.

• *FEMA356*

FEMA356 defines three types of rehabilitation objectives: Basic Safety Objective (BSO), Enhanced and Limited rehabilitation objectives (see Table 1.3). The Basic Safety Objective includes achievement of Life Safety and Collapse Prevention performance levels under earthquake excitations with probability of exceedance in 50 years, equal to 10% and 2% respectively. In comparison with BSO, the Enhanced rehabilitation objectives provide improved building performance (higher performance levels for given seismic hazard levels), while the Limited performance objectives mean worse performance (lower performance levels for given seismic hazard levels). FEMA356 does not give recommendations for choice of rehabilitation objective.

• *Italian seismic code*

The Italian seismic code defines the following rehabilitation goals:

- DL LS- earthquake excitation with probability of exceedance 50% in 50 years, used for Ultimate Limit State (SLU) design of new buildings;

Rehabilitation objectives		Target Building Performance Levels			
		Operational Performance Level (1-A)	Immediate Occupancy Performance Level (1-B)	Life Safety Performance Level (3-C)	Collapse Prevention Performance Level (5-E)
Earthquake Hazard Level	50%/50 year	a	b	c	d
	20%/50 year	e	f	g	h
	BSE-1 (~10%/50 year)	i	j	k	l
	BSE-2 (~2%/50 year)	m	n	o	p

Notes:

1. Each cell in the above matrix represents a discrete Rehabilitation Objective.
2. The Rehabilitation Objectives in the matrix above may be used to represent the three specific Rehabilitation Objectives defined in Sections 1.4.1, 1.4.2, and 1.4.3, as follows:
 k + p = Basic Safety Objective (BSO)
 k + p + any of a, e, i, b, f, j, or n = Enhanced Objectives
 o alone or n alone or m alone = Enhanced Objective
 k alone or p alone = Limited Objectives
 c, g, d, h, l = Limited Objectives

- DS LS- 10%/ 50 years, used for Damage Limitation State (SLD) design of new buildings;
- CO LS- 2%/ 50 years.

The seismic hazard levels can be additionally changed by multiplying the peak ground acceleration (PGA) by importance factor.

The PGA, needed for Collapse Limit State evaluation, can be obtained by amplifying the PGA for Severe Damage Limit State with 50%.

The Italian seismic code allows the assessment to be performed for DL LS and CO LS only.

- *EC8*

EC8 recommends the following rehabilitation goals:

- LS of Damage Limitation- 20%/50 years;
- LS of Significant damage- 10%/50 years;
- LS of Near Collapse- 2%/50 years.

EC8 does not give recommendation if all the three limit states should be evaluated.

- *Comparisons and comments*

FEMA356 gives larger range of possible performance objectives, than the Italian seismic code and EC8.

Evaluations for all the three limit states, included in the Italian seismic code and EC8 is equivalent to Enhanced Performance Objective according to the FEMA356 terminology (see Fig. 1.3). The rehabilitation goals in the Italian seismic code correspond to goals p , k and a , while EC8 aims at p , k and f .

3. KNOWLEDGE LEVELS

The knowledge about the as-built condition of the building (geometry, detailing, material properties, presence of any degradation, etc), is classified as a particular level, according to the source of the collected information. The lower the knowledge level, the more conservative the applied assessment procedure should be. This principle is put into practice by modifying the component capacities using knowledge factors, confidence factors or partial safety factors (see 6.3).

The non-linear analysis procedures (see 4.1.1.3 and 5) require detailed information about the properties of the structure, and therefore, are not applicable when the knowledge level is low.

- *FEMA356*

FEMA356 classifies the knowledge as Minimum, Usual or Comprehensive level, according to the available documentation (design drawings/ construction documentation), condition assessment performed (visual/ comprehensive) and material properties source (drawings/ documents/ usual tests/ comprehensive tests/ default values).

When BSO or Limited rehabilitation objective is chosen, Minimum and Usual knowledge levels should be allowed, while an Enhanced rehabilitation objective requires at least Usual knowledge level to be achieved. The knowledge factor values are shown in Table 3.1.

Table 3.1 Knowledge factors acc. to FEMA356

Rehabilitation objective	BSO or Limited		Enhanced	
	Minimum	Usual	Usual	Comprehensive
Knowledge level	Minimum	Usual	Usual	Comprehensive
Knowledge factor k	0.75	1.0	0.75	1.0

Non-linear analysis procedures are not applicable in the case of Minimum knowledge level.

- *Italian seismic code*

The Italian seismic code classifies the knowledge as Limited (LC1), Adequate (LC2) or Accurate (LC3) level, according to the source of the information on: geometry and reinforcement (original drawings/ visual or full investigation), structural details (design simulation/ limited, extensive or comprehensive in-situ verification/ incomplete or complete set of construction drawings), material properties (common values/ original certificates of executed tests/ original design specifications/ limited, extensive or comprehensive in-situ tests).

The confidence factor values are shown in Table 3.2.

Table 3.2 Confidence factors acc. to Italian seismic code

Knowledge level	Limited (LC1)	Adequate (LC2)	Accurate (LC3)
Confidence factor <i>FC</i>	1.35	1.20	1.0

Non-linear analysis procedures are not applicable in the case of Limited (LC1) knowledge level.

- *EC8*

The knowledge levels in EC8 have essentially the same definition as the Limited (LC1), Adequate (LC2) and Accurate (LC3) levels in the Italian seismic code, but are named Limited (KL1), Normal (KL2) and Full (KL3) respectively.

For each knowledge level, EC8 recommends respective partial safety factors (PSF) for the material properties (see Table 3.3), instead of the global knowledge and confidence factors in FEMA356 and Italian seismic code.

Table 3.3 Partial safety factors acc. to EC8

Knowledge level	Limited (KL1)	Normal (KL2)	Full (KL3)
PSF- definition	$1.20\gamma_m^1$	$1.0\gamma_m$	$0.8\gamma_m$
PSF - concrete	1.80	1.50	1.20
PSF- reinforcing steel	1.38	1.15	0.92

1- γ_m is the partial safety factors for the material properties, recommended in EC8 for seismic design of new buildings.

Non-linear analysis procedures are not applicable in the case of Limited (KL1) knowledge level.

- *Comparisons and comments*

Different from FEMA356, the Italian seismic code and EC8 do not require achievement of knowledge higher than Limited level when the rehabilitation objective is equivalent to Enhanced rehabilitation objective in FEMA356 (see 2.2).

4. STRUCTURAL MODELING AND ANALYSIS PROCEDURES

4.1 Analysis procedures

The analysis procedures for assessment of existing buildings can be divided in two groups: displacement-based procedures (see 4.1.1) and force-based procedures (see 4.1.2).

4.1.1 Displacement-based analysis procedures

The displacement-based procedures are aimed to predict the elastic and inelastic deformation demands, imposed on the structural components by design seismic excitation.

FEMA356, Italian seismic code and EC8 include the following four analysis procedures:

- Linear Static Procedure (LSP);
- Linear Dynamic Procedure (LDP);
- Non-linear Static Procedure (NSP);
- Non-linear Dynamic Procedure (NDP).

LSP, LDP and NDP are briefly summarized in 4.1.1.1 to 4.1.1.3. The Non-linear Static Procedures according to FEMA356, FEMA440, ATC-40, Italian seismic code and EC8 are exposed in details in.5.

For applicability limits of the procedures- see 4.3.

4.1.1.1 Linear static procedure

The structure is modeled as linearly elastic with secant stiffness through the yield point. Pseudo lateral load is applied statically at the floor levels. The magnitude of the load is intended to result in the deformation demands which would be caused by design earthquake. The load is referred as “pseudo”, since it induces internal forces with no physical meaning for components working in the inelastic range. Fundamental assumption of the method is that the structural components possess infinite inelastic deformation capacity.

• *FEMA356*

The base shear, caused by the pseudo lateral load is given as:

$$(4.1) V = C_1 C_2 C_3 (C_m S_a M \cdot g).$$

Where:

- M is the total mass of the building;
- $S_a(T), [g]$ is the elastic pseudo-acceleration spectrum value, corresponding to the fundamental natural period T ;

- $C_m S_a M \cdot g$ is the maximum base shear, corresponding approximately to the base shear of the elastic system responding in its fundamental mode.

Three methods for evaluation of the fundamental period are proposed- analytical (eigenvalue analysis), empirical and approximate.

The expression in the brackets of formula (4.1) alone would give the first order elastic response of the structure to design earthquake. The coefficients C_1 , C_2 and C_3 are intended to:

- C_1 - relates expected maximum inelastic deformations to deformations based on linear elastic theory;
- C_2 - represents the effects of pinched hysteresis shape;
- C_3 - accounts for increased displacements due to dynamic P- Δ effects.

In addition to that, the static P- Δ effects should be considered. Detailed information about the P- Δ effects (static and dynamic) is given in 4.4.

The horizontal forces are distributed along the building height according to:

$$(4.2) F_i = \frac{m_i h_i^k}{\sum_{j=1}^n m_j h_j^k} M$$

Where:

- $m_{i(j)}$ - mass located at floor level i (j);
- $h_{i(j)}$ - height from the base to floor level i (j).

The factor k is intended to reflect the dependence of the response deformed shape of the structure on its flexibility. It is a function of the fundamental period T . For short period structures ($T \leq 0.5s$), k is equal to 1, which means linear distribution of the horizontal displacements, while for $T \geq 2.5s$, k is equal to 2 and the profile of the floor displacements is parabolic. When the fundamental period is between 0.5s and 2.5s, linear interpolation is used for k value calculation.

• *Italian seismic code*

The base shear is given as:

$$(4.3) V = \lambda \cdot S_a(T) M \cdot g$$

Where:

- $S_a(T)$ and M - see (4.1);
- λ - corresponds to C_m from (4.1).

The code recommends an empirical formula for evaluation of the fundamental period T .

The distribution of the horizontal forces along the height of the building follows linear presumed response shape of the structure.

- *EC8*

The only difference in comparison to the Italian seismic code is that EC8 recommends three methods for evaluation of the fundamental natural period T , similarly to FEMA356- analytical (eigenvalue analysis), empirical and approximate.

- *Comparisons and comments*

The Italian code and EC8 follow the equal displacement principle, assuming that the maximum displacements of the elastic and inelastic systems are equal. That can lead to underestimation of the displacement demands on short period structures. The two codes do not also account for dynamic P- Δ effects, but only for static P- Δ effects (see 4.4).

FEMA356 gives more precise distribution of the horizontal forces along the height of flexible buildings, compared to the Italian seismic code and EC8.

4.1.1.2 Linear dynamic procedure

The structure is modeled as linearly elastic with secant stiffness through the yield point. Solution is carried out by Response Spectrum Method with elastic spectrum. Model responses are combined through Square Root of Sum of Squares (SRSS) or Complete Quadratic Combination (CQC) rule. The obtained deformations are adjusted to or just interpreted as the expected demands (elastic and inelastic), imposed on the structure by design earthquake.

- *FEMA356*

The deformations, obtained through Response Spectrum Method with elastic spectrum, are amplified by coefficients C_1 , C_2 and C_3 to reflect the phenomena as inelastic response, pinching and dynamic P- Δ effects (see 4.1.1.1). Static P- Δ effects are also accounted for.

- *Italian seismic code and EC8*

The deformations, obtained through Response Spectrum Method with elastic spectrum, are adopted as expected demands under design earthquake.

- *Comparisons and comments*

The comparisons and comments about the equal displacement principle and dynamic P- Δ effects, made for LSP, are also applicable here (see 4.1.1.1).

4.1.1.3 Nonlinear dynamic procedure

The structural model directly incorporates the non-linear cycle force-deformation relations of the components of the building. The response is directly obtained through numerical integration of the equations of motion, using accelerograms to represent the ground motion.

The Nonlinear Dynamic Procedure is considered the most realistic tool for assessment of the structural behaviour under earthquake excitation.

4.1.2 Force-based linear procedures- Italian seismic code and EC8

The force-based linear procedures are aimed to predict the minimum strength of the structural components, needed to insure the safety of people under design earthquake.

The solution follows the LSP or LDP (see 4.1.1.1 and 4.1.1.2), but using reduced pseudo-acceleration response spectrum, accounting for the ability of the structure to work safely in inelastic regime. The reduced spectrum is obtained from the elastic spectrum using reduction factor q . In general, q depends on many factors such as local ductility and energy dissipation capacity of the structural components, prevailing failure modes, redundancy of the system, structural regularity in plan and elevation, geometry, etc. The applicability of the q -factor approach for design of new buildings is justified since the above parameters can be controlled, to some extent, during the design process. In the case of existing buildings however, the evaluation of proper value of the force reduction factor is very difficult task. On account of that, EC8 is very conservative- $q=1.5$ irrespectively of the structural properties. The Italian seismic code suggests values from 1.5 to 3 without criteria for choice of exact number.

The above considerations are the probable reason why FEMA356 and ATC-40 do not include force-based linear procedure as a tool for assessment of existing buildings.

4.2 2D versus 3D models

The choice of model dimension depends first on the in-plan diaphragm flexibility. The criteria for assessment of the diaphragm flexibility are based on its influence on the seismic demands, imposed on the lateral-force-resisting elements. Many factors influence the diaphragm flexibility: the shape of the floors, the type of the diaphragm and lateral-load-resisting system, the arrangement of the vertical elements in plan, etc. In general, the diaphragms can be classified as rigid (with negligible in plane distortions), flexible (with negligible in-plane stiffness) and stiff (intermediate case).

Buildings with rigid diaphragms can be modeled with 2D models in the two orthogonal structural directions, providing the floor rotations do not considerably increase demands on the structural components in comparison to the demands caused by average floor translations. The magnitude of floor rotations depends mainly on mass, stiffness and strength regularity in plan. Floor mass can be lumped in the floor mass center.

Buildings with flexible diaphragms can be modeled with 2D models, since the response of the lateral-load resisting elements (frames, walls, etc.) is almost independent. Floor mass is distributed among the elements according to the tributary areas.

Buildings with stiff diaphragms should be modeled with 3D models, accounting explicitly for diaphragm flexibility and mass distribution.

In any case, 2D models are not applicable for structures with non-orthogonal bracing system.

Generally, spatial models are preferable to planar models.

- *FEMA356*

Diaphragms are classified according to the ratio of the maximum in-plan diaphragm deformations and average interstorey drift of the vertical lateral-force-resisting elements. They are rigid if the ratio is less than 0.5, flexible- ratio more than 2, and stiff- ratio from 0.5 to 2. The diaphragm deformations and the average drift are evaluated using LSP. The horizontal forces are distributed over the floors planes according to the distribution of mass.

The extent of floor rotations is assessed, using η coefficient, defined as:

$$(4.4) \quad \eta = \max(\delta_{i,\max} / \delta_{i,\text{avg}})$$

where the i^{th} floor horizontal displacements $\delta_{i,\max}$ and $\delta_{i,\text{avg}}$ are denoted on Figure 4.1.a.

η_x and η_y are evaluated separately for excitation in x and y direction respectively. If the value of η is larger than 1.5 in any of the two orthogonal directions, 3D model should be used.

- *Italian seismic code*

Buildings are classified as regular or irregular in plan. Only regular buildings can be modeled with two planar models in the two orthogonal directions. The criteria for regularity include the in-plan stiffness of the diaphragms with respect to the lateral stiffness of the vertical elements, as well as in-plan mass and stiffness symmetry and compactness. Criteria related to the shape of the floors are also given. Buildings with diaphragms different than rigid are classified as irregular and consequently, should be modeled with spatial models.

- *EC8*

In addition to Italian code criteria, EC8 defines quantitative assessment of diaphragm flexibility and in-plan mass and stiffness regularity.

The diaphragm is taken as being rigid, if the floor displacements of the building, modeled with deformable diaphragms, do not exceed with more than 10% the floor displacements of the building, modeled with rigid diaphragms.

The mass and stiffness are regularly distributed in plan if:

$$(4.5) \quad \begin{aligned} e_{0x} / r_x &\leq 0.3 \\ r_x / l_s &\geq 1 \end{aligned}$$

where e_{0x} is the eccentricity of mass center (CM) with respect to center of rigidity (CR) (see Figure 4.1.a), r_x is the torsional radius and l_s is the radius of gyration of the floor mass in plan.

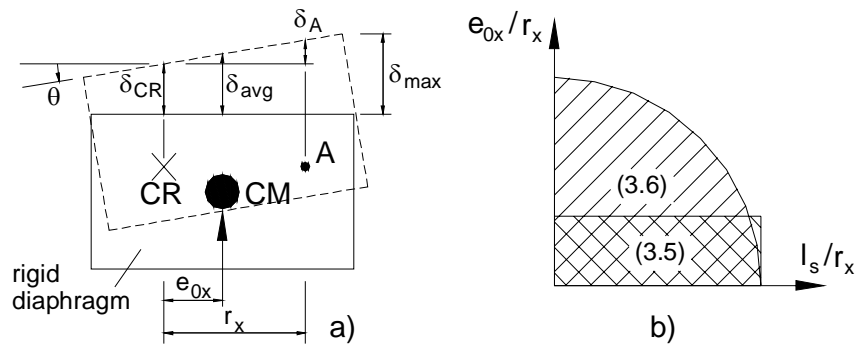

Figure 4.1. Criteria for regular distribution of mass and stiffness in plan acc. to EC8: a) Interpretation of e_{0x} to r_x ratio; b) Limits on e_{0x}/r_x and l_s/r_x ratios

The physical meaning of the two criteria can be explained for one-storey building (3 DOF system). The first expression is the ratio of the displacement of point A due to rotation around the center of rigidity (CR) and the CR displacement (see Figure 4.1.a). It shows the amplification of the drift demands due to floor rotations when only translation inertia is accounted for. The second expression is the ratio of the natural vibration frequency associated with the rotational mode and that, associated with the translational mode of vibration, under the assumption that CM and CR coincide. It reflects the possibility for increased drifts demands due to rotation inertia.

The proof of the above interpretation is shown bellow:

$$(4.6) \quad \frac{\delta_A}{\delta_{CR}} = \frac{E \cdot e_{0x} r_x / k_\theta}{E / k_y} = \frac{e_{0x} r_x}{k_\theta / k_y} = \frac{e_{0x} r_x}{r_x^2} = \frac{e_{0x}}{r_x},$$

$$(4.7) \quad \frac{\omega_\theta}{\omega_y} = \frac{\sqrt{k_\theta / J_m}}{\sqrt{k_y / m}} = \frac{\sqrt{k_\theta / k_y}}{\sqrt{J_m / M}} = \frac{r_x}{l_s},$$

where k_θ is the rotational stiffness of the system, k_y is the translational stiffness in y direction, M is the mass and J_m is the mass moment of inertia.

Even if the structure is not classified as regular, 2D models can be used, providing that several conditions are met. They concern the rigidity of partition walls, building height and diaphragm rigidity. Expressions (4.5) are replaced with more liberal expression (4.8) (see Figure 4.1.b):

$$(4.8) \quad r_x^2 \geq e_{ox}^2 + l_s^2$$

- *Comparisons and comments*

FEMA356 does not give recommendations about the analysis type used for η coefficient evaluation. Neither of the codes takes into account strength distribution in plan as a property of the structure that can trigger rotational response.

The Italian code does not give quantitative criteria for diaphragm flexibility and in-plan mass and stiffness regularity.

4.3 Choice of analysis procedure

Static procedures are applicable when no significant participation of higher modes is expected. The load patterns, used for static analyses, are not able to reflect the deformed shape of the structure when higher mode effects are involved. The higher mode participation depends mainly on the mass and stiffness regularity and on the allocation of the natural periods of the structure with respect to earthquake predominant periods. Structures with non-orthogonal lateral-force-resisting system should be analyzed with dynamic procedures.

Linear procedures (LSP and LDP) should predict the magnitude and distribution of the displacement demands due to non-linear response of the structure under design earthquake. Therefore, they are applicable when the structure remains almost elastic or when expected non-linear deformations are uniformly distributed all over the building (no weak-storey mechanisms or severe inelastic torsion are present). Demand to Capacity ratios (DCRs), based on linear analysis, can be used for assessment of the distribution of inelastic deformations.

- *FEMA356*

The applicability of the LSP instead of LDP is proved if four conditions for mass and stiffness regularity in plan and along the height are met:

- (1) The building does not have severe torsional stiffness irregularity.
- (2) The building does not have severe vertical mass or stiffness irregularity.
- (3) The ratio of the dimensions of adjacent storeys should not exceed 1.4.
- (4) The building has orthogonal lateral-force-resisting system.

The first two criteria are based on the distribution of the drifts (in plan and along the height respectively) from LSP.

In addition to that, the fundamental natural period of the structure T should be:

$$(4.9) \quad T \leq 3.5T_s$$

where T_s is the period separating the constant acceleration from constant velocity region of the pseudo-acceleration response spectrum.

Linear analyses can be applied if the structure remains nearly elastic:

$$(4.10) \quad DCRs \leq 2.$$

Otherwise, uniform distribution of inelastic deformation should be proved. The check is subdivided into two:

- (1) Severe weak storey irregularity- the ratio of the average storey DCRs of adjacent storeys should be not more than 1.25.

(2) Severe in-plan discontinuity irregularity- the ratio of the component DCRs in one storey should not be more than 1.5.

The force demands are calculated for linear elastic behaviour of the structure ($C_1=C_2=C_3=1$). DCRs are based on the critical component action (such as axial force, flexure, shear). The component DCRs participate in the average storey DCR proportionally to the shear force they attract, i.e. DCRs of stiffer elements have more importance. If stiffer component enters in the inelastic range, the reduction of the total storey stiffness is larger than that in the case of softer element yielding.

In addition to (1) and (2), specific verification is included for RC frame structures:

(3) The average DCRs of columns in a storey should not exceed the average DCRs of the beams above the storey if the column ductility demands are more than half of their ductility capacity. The calculation of the column ductility capacity and ductility demand is discussed in 6.4.1.

NDP should be preferred to NSP if:

$$(4.11) V_{90\%} / V_{1st} > 1.3$$

Where:

- $V_{90\%}$ - storey shear forces from LDP and modes giving 90% mass participation;
- V_{1st} - storey shear forces based on first mode only.

Even when that condition is met, NSP can still be applied, but together with LDP. In that way the higher mode effects are accounted for to some extent.

• *Italian seismic code*

Usage of LSP instead of LDP is allowed when the structure is classified to be regular in elevation and the first natural vibration period T is less than $2.5T_s$. Regularity is proved if several criteria for stiffness, mass and strength distribution along the height of the building are met.

The liner procedures are applicable, if the following two conditions are observed:

$$(4.12) DCR_{max}/DCR_{min} \leq 2.5 \text{ for deformation-controlled actions;}$$

$$(4.13) DCRs \leq 1 \text{ for the force-controlled actions.}$$

The deformation- and force-controlled actions (also referred as ductile and brittle mechanisms) are defined in 6.2.

DCR_{max} and DCR_{min} are the maximum and minimum Demand-to-Capacity Ratios among the DCRs with values larger than 2. The force demands on the brittle mechanisms are obtained from the analysis if no yielding associated with the adjacent ductile mechanisms is expected. Otherwise, the limit-analysis principles should be followed.

The Italian seismic code does not impose any limitation on the applicability of the force-based linear procedures.

- *EC8*

The differences between the Italian code procedure and EC8 procedure are the following:

$$(4.14) T_1 \leq \min(4T_s; 2s)$$

$$(4.15) DCR_{max}/DCR_{min} \leq 2 \div 3 \text{ for the ductile mechanisms.}$$

DCR_{max} and DCR_{min} are the maximum and minimum Demand-to-Capacity Ratios among the DCRs with values larger than 1.

- *Comparisons and comments*

EC8 and the Italian code include in-elevation strength distribution as a criterion for choice between LSP and LDP, although they both do not reflect the strength.

According to FEMA356 the structure remains nearly elastic when DCRs for ductile and brittle mechanisms have values less than 2. The Italian seismic code gives limiting value of 2 for ductile and 1 for brittle mechanisms. EC8 recommends unity for both force- and deformation-controlled actions, which is the theoretical limiting value. FEMA356 allows DCRs for brittle mechanisms to exceed unity, because the force demands are not based on limit-analysis principles, but on linear elastic analysis.

EC8 and the Italian code do not define limitations on the applicability of the Non-linear Static Procedure (NSP).

4.4 P-Δ effects

The increase of the deformation demands, due to the action of the gravity loads through the deformed configuration of the structure, is referred as P-Δ effects or also second order effects. The P-Δ effects can be subdivided into:

- 1) Static P-Δ effects- increased deformations due to the reduced strength and initial stiffness;
- 2) Dynamic P-Δ effects- increased deformations due to the negative post-yield stiffness.

This can be demonstrated on the simple system, shown on Figure 4.2.

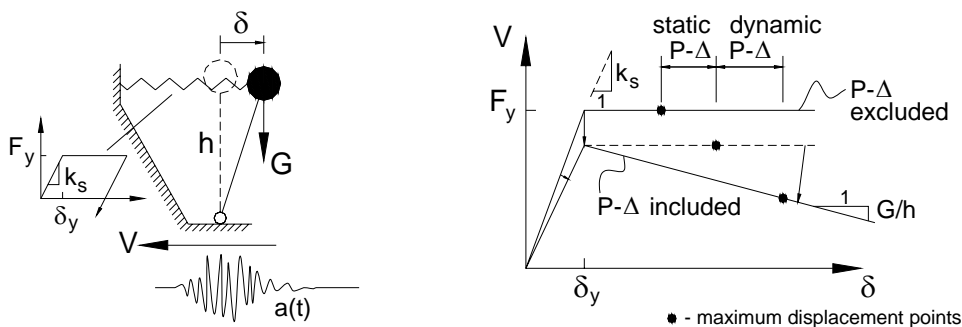

Figure 4.2. Static and dynamic P-Δ effects

• *FEMA356*

When linear procedures (LSP and LDP) are used, the P- Δ effects are accounted for through stability coefficient θ , evaluated for the linearly elastic structure (no C_1 coefficients included):

$$(4.16) \theta_i = \frac{P_i \delta_i}{V_i h_i}$$

Where:

- P_i - the portion of the total weight of the building, acting on the vertical elements of the i^{th} storey;
- δ_i - lateral drift in storey i , in the direction under consideration, at its center of rigidity;
- V_i - the total calculated storey shear force in the direction under consideration due to earthquake response;
- h_i - storey height.

The stability coefficient gives approximately the ratio of the total storey moments, corresponding to the gravity loads and to the inertial forces.

If $\theta_i < 0.1$, the static P- Δ effects are negligible. When $0.1 \leq \theta_i \leq 0.33$, seismic forces and deformations in storey i shall be increased by factor $1/(1-\theta_i)$. If $\theta_i > 0.33$, the structure should be considered unstable and rehabilitation measures are needed.

The dynamic P- Δ effects are accounted for through the coefficient C_3 (see 4.1.1.1 and 4.1.1.2), which amplifies the seismic forces and deformations in addition to the $1/(1-\theta)$:

$$(4.17) C_3 = 1 \text{ if } \theta < 0.1 \text{ and} \\ C_3 = 1 + 5(\theta - 0.1)/T \text{ if } \theta \geq 0.1,$$

where θ is the maximum value of θ_i of all storeys.

The stiffer the structure (shorter fundamental period T), the more pronounced the dynamic P- Δ effect is. That trend can be explained by the simple structure from Figure 4.2. For fixed mass (which means also fixed gravity load), a structure with shorter natural period has larger ratio post-yield to initial stiffness and consequently is more sensitive to dynamic P- Δ effects. The role of the stability coefficient in (4.17) is similar. In the case of the structure from Figure 4.2 it is equal to the post-yield to initial stiffness ratio.

When NSP is used, the static P- Δ effects are accounted for directly in the push-over analysis by including geometric nonlinearity. The dynamic P- Δ effects are reflected through coefficient C_3 (for details- see 5).

In the case of NDP, the two kinds of P- Δ effects are part of the analysis.

- *Italian seismic code and EC8*

The two codes account for the static P- Δ effects in the some way as FEMA356, but the dynamic P- Δ effects are not considered.

4.5 Horizontal torsion

Horizontal torsion is caused by non-symmetric distribution of mass, stiffness and strength, but even in “ideally” symmetric structures it can be provoked by rotational component of the excitation. The torsion based on the computed distribution and translational ground motion is called actual torsion. Accidental torsion is a consequence of unfavorable deviation from the assumed distributions and presence of rotational excitation component.

The actual torsion is directly accounted for when 3D models are applied. The accidental torsion could be considered by introducing accidental eccentricities to the inertial forces, i.e. by displacing the floor mass centers.

When 2D models are exploited, the actual and accidental torsion should be included indirectly by means of increased force/displacement demands.

- *FEMA356*

In the case of linear procedures, applied to 3D rigid floor models, i^{th} storey accidental torsional moments are calculated as:

$$(4.18) M_{ai} = V_{xi} 5\%L_i + V_{yi} 5\%B_i$$

Where:

- V_{xi} and V_{yi} - storey shear forces from analysis;
- L_i and B_i - dimensions of the diaphragm above the i^{th} storey, perpendicular to V_{ix} and V_{iy} respectively.

The moments M_{ai} are additionally multiplied by coefficient $A=(\eta/1.2)^2 \leq 3$ if $\eta > 1.2$ (η is defined by (4.4) and should correspond to the main direction of the excitation). Torsional moments, corresponding to the torsional storey moments M_{ai} , are then applied at the floor levels to obtain the component demands due to accidental torsion.

The A coefficient accounts for increased torsion due to strength irregularity, not reflected in the linear models. This effect can be demonstrated by the simple one-storey building, shown on Figure 4.3. The two RC walls in y direction are identical, but the accidental eccentricity introduces slight strength irregularity (the DCRs of the two walls are slightly different). LSP and NSP (see 4.1.1.1 and 5) predict similar average roof displacement, but LSP underestimates the rotations. Structures with low level of redundancy are likely to be more sensitive to this aspect.

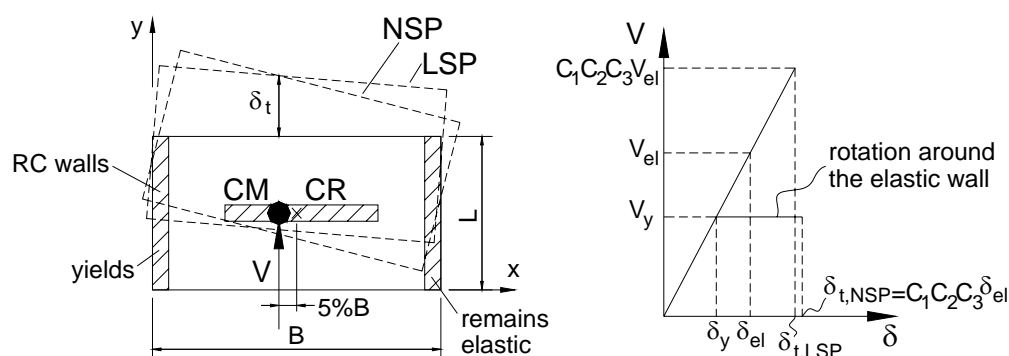

Figure 4.3. Amplification of the torsional effects due to strength irregularity

When non-linear procedures are applied to 3D rigid floor models, accidental torsion is accounted for by displacing the mass center (CM) of each floor in $\pm 5\%L_i$ and $\pm 5\%B_i$ along y and x axes respectively.

Accidental torsion is not accounted for if 3D stiff or flexible floor models are used. This can be attributed to lesser sensitivity of these systems to changes in the distribution of mass- small shift of the mass center do not leads to as global effect as in case of rigid diaphragms.

When 2D models of buildings with rigid floors are used, actual and accidental torsional effects are taken into account approximately as follows:

- LSP and LDP- amplifying the force and deformation demands by η_x or η_y according to the direction of analysis concerned;
- NSP- amplifying the target displacement by η_x (η_y);
- NDP- amplifying the excitation, i.e. accelerogram, by η_x (η_y).

If a building with flexible diaphragms is analyzed by 2D model, no amplification is needed, since the lateral-force-resisting elements respond almost independently.

• *Italian seismic code*

Generally, the code recommends the accidental torsion in 3D models to be accounted for by displacing the mass center (CM) of each floor in $\pm 5\%L_i$ and $\pm 5\%B_i$ along the y and x axes respectively.

For 3D linear procedures applied, the accidental torsion storey moments M_{ai} are evaluated using (4.18), where V_{xi} and V_{yi} are obtained from LSP. This approach can not be applied to buildings with non-rigid diaphragms, since the concentrated moments on the floor levels would produce unrealistic diaphragm distortions.

When 2D linear models are used, the accidental torsion is accounted for as the force and deformation demands are amplified by factor δ_x or δ_y according to the plane of analysis:

$$(4.19) \delta_x = 1 + 0.6 \frac{x}{L_e}$$

Where:

- x - the distance of the component under consideration from the center of mass of the building in plan, measured perpendicularly to the direction of the seismic action;
- L_e - the distance between the two outermost lateral-load-resisting components, measured perpendicularly to the direction of the seismic action.

The Italian code does not give recommendations for the evaluation of torsional effects in the case of 2D non-linear analyses.

- *EC8*

The only difference between EC8 and the Italian code is that δ coefficients are also used when 2D NSP is applied. In this case δ amplifies the target displacement.

- *Comparisons and comments*

When 3D models with non-rigid diaphragms are used, FEMA356 recommends no accidental eccentricities to be accounted for, while according to the Italian seismic code and EC8, the floor mass centers should be displaced in $\pm 5\%L_i$ and $\pm 5\%B_i$ along the y and x axes respectively.

The evaluation of the torsional effects according to the three codes in case of 2D models is similar. The demands are amplified by coefficient η in FEMA356 and δ in the Italian code and EC8. The η coefficient reflects actual and accidental torsion, while δ is aimed to account for accidental torsion only. All the three codes imply that 2D analyses predict well the average floor displacements (η is the ratio of the maximum to average floor displacement and $\delta \approx 1$ for components near the axis of the building). It seems that FEMA356 approach is conservative for components near the building axes.

The A coefficient in FEMA356 is aimed to capture the effect of inelastic torsional response. Consequently, it should be based on the strength distribution in the building plan rather than on the initial linear properties of the structure.

4.6 Multidirectional effects

The earthquake excitation has spatial character- it acts simultaneously in all the three orthogonal directions, imposing deformation demands on the building.

The concurrent action of the excitation along the two horizontal orthogonal axes should not be considered, when the building is symmetric in plan with independent orthogonal lateral-force-resisting systems. In that case, excitation along one of the structural axes would impose demands on the perpendicular bracing system due to accidental torsion only. These demands

are assumed to be negligible in comparison to the demands from excitation in the plane of bracing system under consideration.

When 3D models are analyzed by non-linear dynamic procedures, the equations of motions are numerically integrated for horizontal motion of the base.

Usually, the effects of the vertical component of the seismic excitation are neglected, since they are negligible in comparison with the forces due to gravity loads. Exceptions are particular cases, such as presence of large spans, long cantilevers, beams supporting columns, etc. These cases are not considered here.

- *FEMA356*

The structure is analyzed independently in the two orthogonal directions, accounting for P- Δ effects and horizontal torsion, and the demands are combined. When accidental torsion is considered by (4.18), it is added after the combination of the results from the two directions.

The combination rules are as follows:

- LSP and LDP- 100% of the forces and deformations from excitation in x direction plus 30% of the forces and deformations from excitation in y direction and vice versa;
- NSP and 2D NDP- forces and deformations associated with 100% of the design displacement from excitation in x direction plus forces associated with 30% of the design displacement from excitation in y direction and vice versa.

- *Italian seismic code*

With respect to the linear procedures, the Italian code recommends the same procedure as FEMA356.

When NSP or 2D NDP are used, no combination of the demands, obtained from independent analyses along the two orthogonal axes, should be considered.

- *EC8*

In addition to FEMA356 and the Italian code, EC8 permits also the SRSS combination rule to be applied, when linear analyses are used.

No recommendations are given for multidirectional effects in case of 2D NSP and 2D NDP.

If 3D NSP is used, “100%x+30%y” rule or SRSS rule should be applied for the forces and deformations, corresponding to the target displacements in the two orthogonal directions.

- *Comparisons and comments*

The main difference between the three codes is the combination of the demands, obtained by independent NSP in the two orthogonal directions of 3D model (3D NSP). Any combination

does not have rigorous physical meaning, since path-dependent nonlinearity is present. The most conservative approach is adopted in EC8- both forces and deformations are combined (forces and deformations are used for verification of brittle and ductile mechanisms respectively- see 6.4.2). FEMA356 takes the safe side for brittle mechanisms only, assuming that this kind of failure is critical for the building safety. The most liberal is the Italian code, using the demands from unidirectional analyses.

EC8 allows application of the SRSS rule, which generally gives a safe side estimate of the probable values of actions, acting simultaneously with the action under consideration. For instance, a common column of two orthogonal moment-resisting frames in regular building should be checked for the maximum possible moments along its two principal axes, applied simultaneously.

4.7 Summary

The procedures for choice of model dimension and analysis type are presented here as flow charts. The issue of whether to account for horizontal torsion and multidirectional effects is referred too.

• *FEMA356*

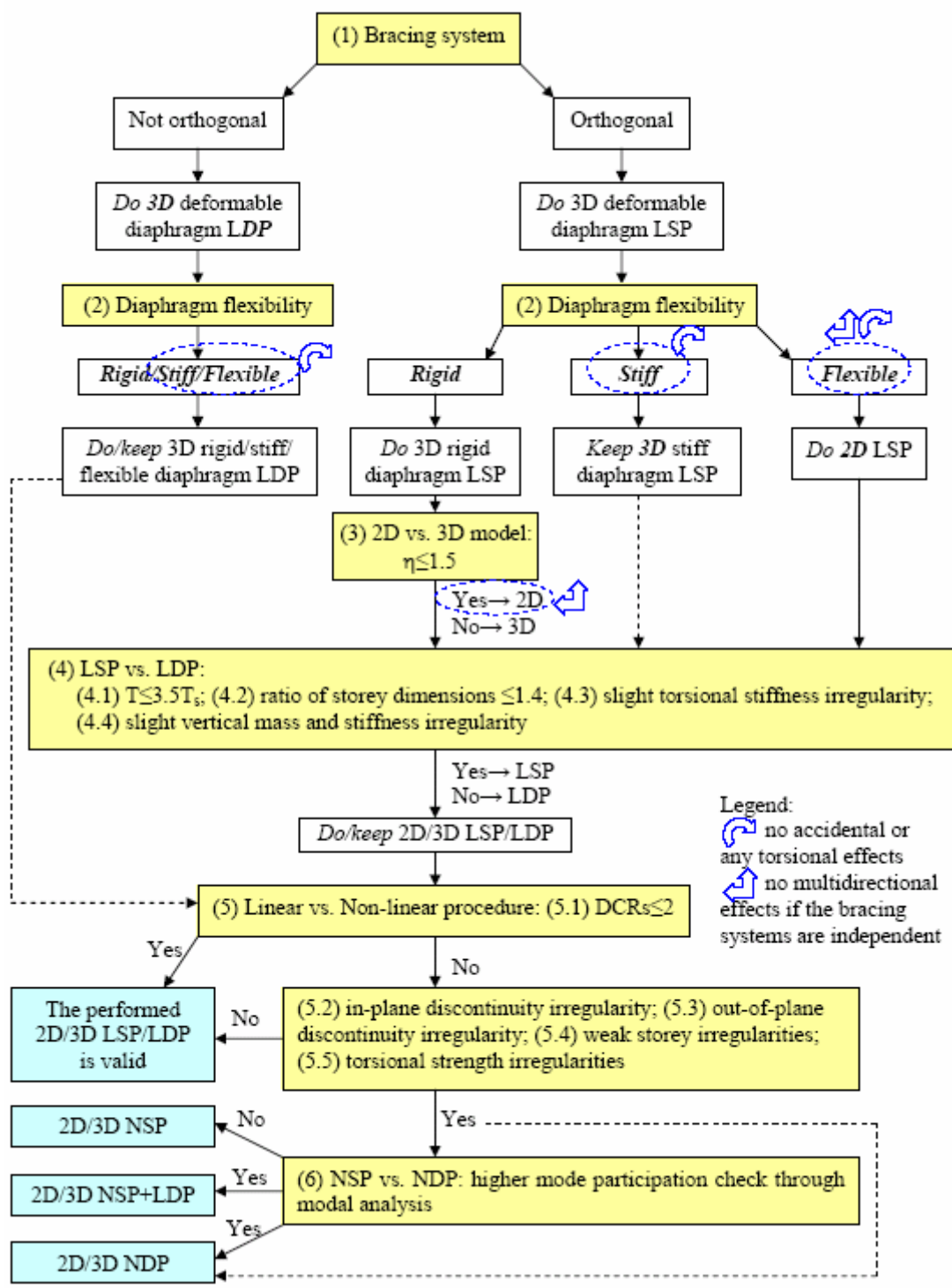

• *Italian seismic code*

The procedure in Italian seismic code is very similar to that in EC8, presented in the following flow chart.

• EC8

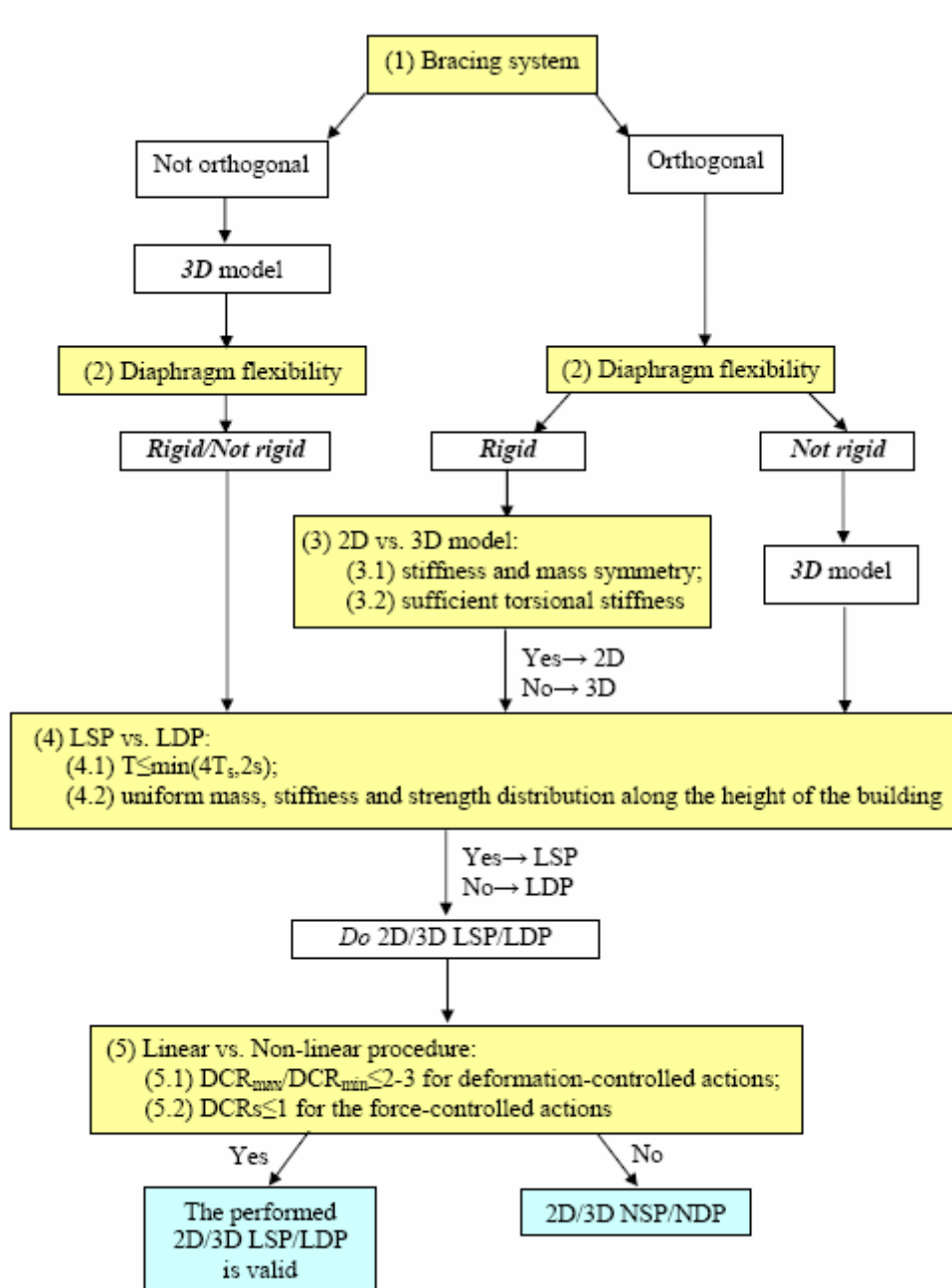

• Comparisons and comments

The general FEMA356 procedure is based directly on the quantities that govern the structural response. This makes it difficult for practical application. Ideally, in order to check the applicability of 2D model for example, the designer should perform at least 3D linear static analysis accounting for deformability of the floors. Opposite, Italian seismic code and EC8 use indirect criteria, resulting in simple for application procedure.

5. NON-LINEAR STATIC PROCEDURE

The model directly incorporates the non-linear force-deformation relations of the structural components (material non-linearity) and accounts for P- Δ effects (geometric non-linearity). The structure is first subjected to gravity loads. Horizontal forces (load vector), representing the inertia forces, are then statically applied (push-over analysis). The analysis is carried-out under monotonically increasing control node displacement. The control node is usually located at the center of mass of the roof. The base shear is traced against the control node displacement (push-over curve or capacity curve), as each point of the curve represents possible state of the structure during an earthquake excitation.

The maximum probable control node displacement under design earthquake (target displacement or performance point) should be evaluated. The corresponding deformations and internal forces represent the seismic demand imposed on the structural components.

The target displacement is obtained by modification of the maximum displacement of a non-linear SDOF system, subjected to design earthquake excitation. This system is known as Equivalent Single Degree of Freedom (ESDOF) system and its properties (mass and force-displacement relationships) are obtained through transformation of the properties of the MDOF system (floor masses, modal parameters, push-over curve).

5.1 Non-linear modeling

The structure reaches the maximum state of deformations, undergoing a number of cycles at lower deformation levels. Therefore, the component force-deformation relationships should rather represent a backbone curve of the hysteretic response, than monotonic loading curve.

The backbone curve differs from the monotonic one, since the load-bearing mechanisms degrade with consecutive cycles of inelastic deformations (cycle strength degradation). The cyclic degradation depends mainly on the deformation history and the mechanism, governing the component response. The component deformation history is not known in advance and it is influenced by many factors, as global structural parameters, excitation type, etc. The effect of cyclic degradation is more pronounced in case of short-period buildings and long duration excitations, since the components experience large number of cycles. On the contrary, near field excitations do not provoke significant degradation.

The mechanisms of response are defined as ductile (deformation-controlled actions) and brittle (force-controlled actions) (see 6.1 and 6.2). It could be expected that the number of inelastic excursions decreases with decreasing component ductility capacity. At limit, when the ductility is 1, the first inelastic pulse causes component failure. Consequently, some brittle elements can be well represented by their monotonic force-displacement curves.

- *FEMA356 and ATC-40*

All the structural components (primary and secondary) should be included in the model. The given force-deformation relations correspond to earthquake loading, involving three fully reversed deformation cycles to design deformation levels, in addition to similar cycles to

lesser deformation levels. The properties should be modified, if increased number of design level cycles is expected as in case of short-period structures or long duration excitation.

For modeling of concrete beams and columns, FEMA356 proposes model with concentrated plastic hinges (lumped plasticity model). The locations of possible plastic hinges should be specified in advance (typically the ends of the element) and should be verified at the end of the analysis. A hinge opens when the bending moment reaches the yield moment of the section under consideration and closes when the hinge rotation changes its sign. The presumed locations of the hinges are realistic if the distribution of the bending moments is statically possible, i.e. the moments in the elastic region of the element are within the elastic limits.

The stiffness of the elastic part of the component should correspond to the secant value through its yield point. FEMA356 gives approximate values for flexural, shear and axial stiffness, expressed as a portion of the stiffness of the gross concrete section. The values for columns depend on the magnitude of axial force, since it affects the extent of cracking. The higher the compression force, the less the cracking, the higher the stiffness.

The hinge moment-rotation relationships, proposed in FEMA356, are schematically shown in Figure 5.1.

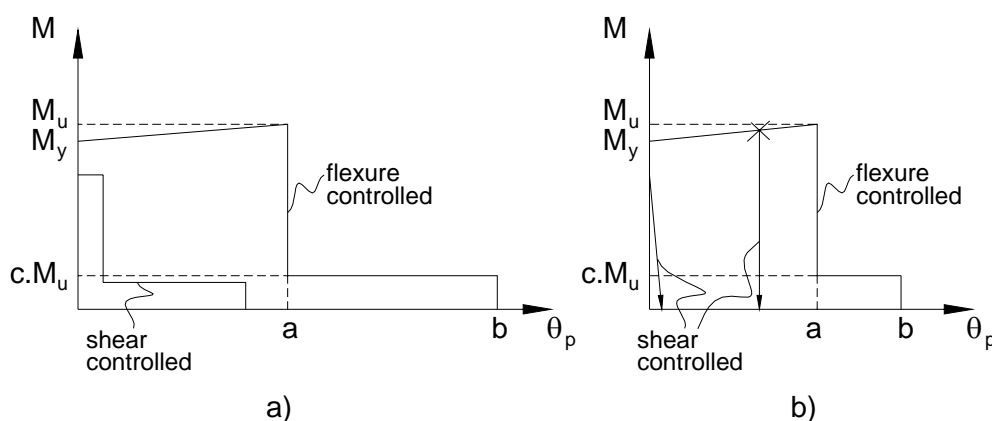

Figure 5.1. Typical plastic hinge $M-\theta$ relationships: a) beams; b) columns

The yield moment M_y and the strength M_u of the section can be calculated using established principles of mechanics (equilibrium, material stress-strain relationships, plane sections hypothesis).

Plastic rotation a corresponds to significant resistance degradation and is associated with crushing of the compression zone of the section or steel rapture. Rotation b corresponds to total resistance degradation. It can be assumed that at this level of deformations the beams fail in shear along the flexural cracks, while the columns are not able to support gravity loads. In general, the rotation capacity of the plastic zones depends on their length and the capacity of the section to develop plastic deformations.

The plastic deformations are usually spread within the element near its ends (along normal and inclined cracks) and within the joint in which the element frames (steel yield penetration). Under the idealization that the cracks are normal to the element axis and the concrete does not possess tension strength, the length of the plastic zone within the element is:

$$(5.1) L_p \approx \left(1 - \frac{M_y}{M}\right) \frac{M}{V} = \left(1 - \frac{M_y}{M}\right) L_V,$$

where M and V are the internal forces at the end section and L_V - shear span (see Figure 5.2). Expression (5.1) loses its validity when L_V tends to infinity or when the plastic hinging does not occur near the end of the element. Presence of inclined cracks increases the plastic zones length (tension shift). The shift is proportional to the height of the section.

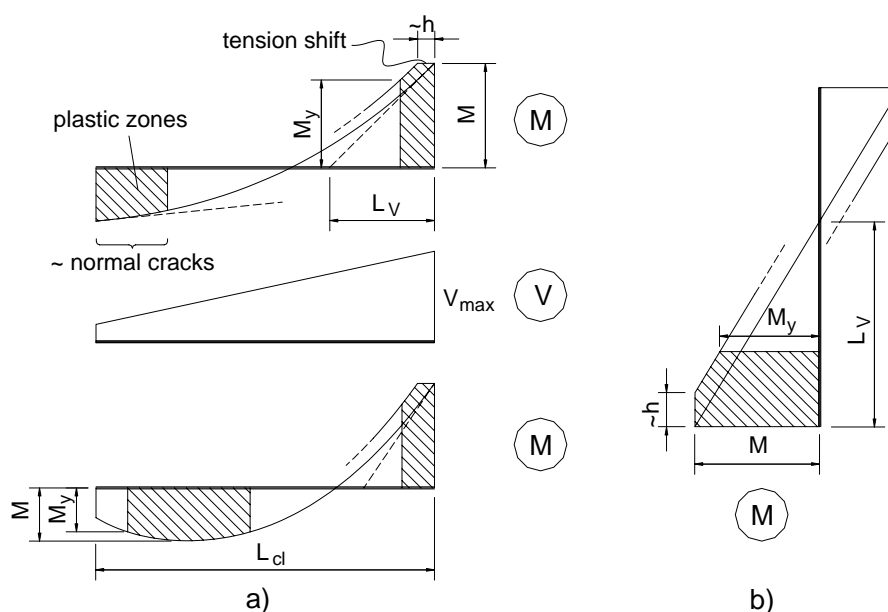

Figure 5.2. Plastic zone length: a) beams; b) columns

The capacity of the section to develop plastic deformations could be characterized by its plastic curvature. It generally increases with decreasing amount of tension reinforcement, increasing amount of compression reinforcement, increasing compression zone width, decreasing section height, decreasing compression force and increasing confinement of the concrete core.

In summary, the plastic rotation capacity of beam end regions is lower when the top reinforcement is in tension, because:

- the shear span L_V is shorter as a consequence of the gravity loads (see Figure 5.2);
- the reinforcement at the top of the section is usually more than that at the bottom as a result of the gravity loads too;
- the bottom width of the section is much smaller than at the top (the sections are usually T-shaped).

The plastic rotation capacity of the column end regions is independent of the direction of hinge opening, since the sections are usually symmetric and the shear span does not vary significantly during the response.

The plastic rotation capacities, proposed in FEMA356, are shown in Table 5.1 and Table 5.2 for beams and columns respectively. It should be pointed out, that the values are independent of the shear span and the height of the section, in contradiction to the considerations made above. At the other hand, the given capacities depend on the magnitude of shear at the hinge location. The higher the shear is, the lower the plastic rotation capacity. This tendency could be explained by the mechanism of force transfer at the face of the beam-column joint. A wide flexural crack forms at this location and almost all the shear force “passes” through the compression zone of the section, causing its earlier disintegration. This effect further supports the conclusion that the rotation capacity of the beam end regions is lower when the top reinforcement is in tension, because the shear reaches its maximum when yielding of the top reinforcement develops (see Figure 5.2).

If the behaviour of the end regions is controlled by inadequate embedment into the beam-column joint, the moment capacity of the section should be based on reduced steel strength. Plastic deformations are concentrated near the face of the joint (steel pull out), resulting in low rotation capacities (see Table 5.1 and Table 5.2).

In some cases, the flexural yielding of end section is followed by shear failure along diagonal crack. This effect is attributed mainly to degradation of the concrete mechanisms, participating in shear transfer, when the element is cycled within the inelastic range. FEMA356 reflects the phenomenon by reduction of the concrete contribution to the shear resistance of columns as a function of the displacement ductility demand (see Figure 5.1 and Figure 5.3). The steel contribution is reduced if the stirrups are not adequately anchored. In this case the spalling of concrete cover at high ductility levels is critical. It should be also pointed out, that V_C is higher for columns with $L_s/h < 2$, since part of the shear force in short columns is transferred by direct diagonal compression.

According to FEMA356, a beam end region, at which the shear strength is reached before flexural yielding, possesses capacity to develop plastic deformations (see Figure 5.1 and Table 5.2). This effect can be attributed to dowel action of the tension reinforcement. It redistributes the shear force, carried by concrete mechanisms, to stirrups outside the inclined crack. The flexural model is kept: the bending moment remains constant and concentrated rotations take place. This is not physically meaningful, since the shear force can further increase in case the opposite end of the beam is still elastic. In reality, the shear force remains equal to the shear strength and concentrated shear deformations develop.

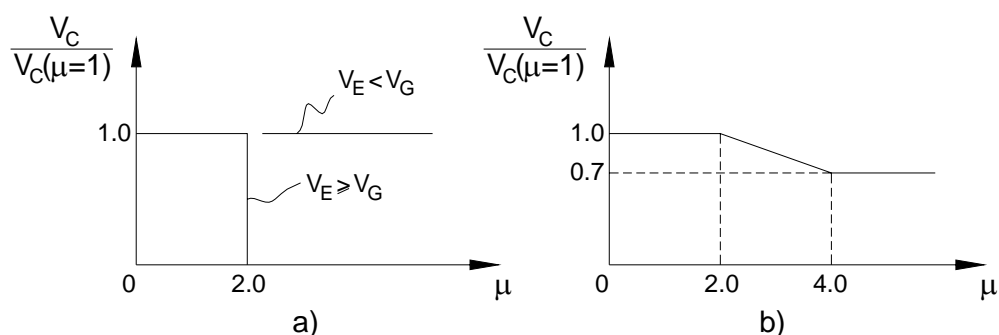

Figure 5.3. Shear force, carried through concrete mechanisms: a) beams (ACI-318); b) columns

Table 5.1 Plastic rotations- beams

Conditions	Modeling Parameters ³					Acceptance Criteria ³				
	Plastic Rotation Angle, radians		Residual Strength Ratio	Plastic Rotation Angle, radians		Performance Level				
				IO	Component Type					
	a	b	c		Primary		Secondary			
					LS	CP	LS	CP		
i. Beams controlled by flexure¹										
$\frac{\rho - \rho'}{\rho_{bal}}$	Trans. Reinf. ²	$\frac{V}{b_w d \sqrt{f'_c}}$								
≤ 0.0	C	≤ 3	0.025	0.05	0.2	0.010	0.02	0.025	0.02	0.05
≤ 0.0	C	≥ 6	0.02	0.04	0.2	0.005	0.01	0.02	0.02	0.04
≥ 0.5	C	≤ 3	0.02	0.03	0.2	0.005	0.01	0.02	0.02	0.03
≥ 0.5	C	≥ 6	0.015	0.02	0.2	0.005	0.005	0.015	0.015	0.02
≤ 0.0	NC	≤ 3	0.02	0.03	0.2	0.005	0.01	0.02	0.02	0.03
≤ 0.0	NC	≥ 6	0.01	0.015	0.2	0.0015	0.005	0.01	0.01	0.015
≥ 0.5	NC	≤ 3	0.01	0.015	0.2	0.005	0.01	0.01	0.01	0.015
≥ 0.5	NC	≥ 6	0.005	0.01	0.2	0.0015	0.005	0.005	0.005	0.01
ii. Beams controlled by shear¹										
Stirrup spacing $\leq d/2$			0.0030	0.02	0.2	0.0015	0.0020	0.0030	0.01	0.02
Stirrup spacing $> d/2$			0.0030	0.01	0.2	0.0015	0.0020	0.0030	0.005	0.01
iii. Beams controlled by inadequate development or splicing along the span¹										
Stirrup spacing $\leq d/2$			0.0030	0.02	0.0	0.0015	0.0020	0.0030	0.01	0.02
Stirrup spacing $> d/2$			0.0030	0.01	0.0	0.0015	0.0020	0.0030	0.005	0.01
iv. Beams controlled by inadequate embedment into beam-column joint¹										
			0.015	0.03	0.2	0.01	0.01	0.015	0.02	0.03

1. When more than one of the conditions i, ii, iii, and iv occurs for a given component, use the minimum appropriate numerical value from the table.

2. "C" and "NC" are abbreviations for conforming and nonconforming transverse reinforcement. A component is conforming if, within the flexural plastic hinge region, hoops are spaced at $\leq d/3$, and if, for components of moderate and high ductility demand, the strength provided by the hoops (V_h) is at least three-fourths of the design shear. Otherwise, the component is considered nonconforming.

3. Linear interpolation between values listed in the table shall be permitted.

Table 5.2 Plastic rotations- columns

Conditions			Modeling Parameters ⁴			Acceptance Criteria ⁴				
			Plastic Rotation Angle, radians		Residual Strength Ratio	Plastic Rotation Angle, radians				
						Performance Level				
			a	b	c	IO	Component Type			
Primary		Secondary								
				LS	CP	LS	CP			
i. Columns controlled by flexure¹										
$\frac{P}{A_g f'_c}$	Trans. Reinf. ²	$\frac{V}{b_w d \sqrt{f'_c}}$								
≤ 0.1	C	≤ 3	0.02	0.03	0.2	0.005	0.015	0.02	0.02	0.03
≤ 0.1	C	≥ 6	0.016	0.024	0.2	0.005	0.012	0.016	0.016	0.024
≥ 0.4	C	≤ 3	0.015	0.025	0.2	0.003	0.012	0.015	0.018	0.025
≥ 0.4	C	≥ 6	0.012	0.02	0.2	0.003	0.01	0.012	0.013	0.02
≤ 0.1	NC	≤ 3	0.006	0.015	0.2	0.005	0.005	0.006	0.01	0.015
≤ 0.1	NC	≥ 6	0.005	0.012	0.2	0.005	0.004	0.005	0.008	0.012
≥ 0.4	NC	≤ 3	0.003	0.01	0.2	0.002	0.002	0.003	0.006	0.01
≥ 0.4	NC	≥ 6	0.002	0.008	0.2	0.002	0.002	0.002	0.005	0.008
ii. Columns controlled by shear^{1, 3}										
All cases ⁵			—	—	—	—	—	—	.0030	.0040
iii. Columns controlled by inadequate development or splicing along the clear height^{1, 3}										
Hoop spacing ≤ d/2			0.01	0.02	0.4	0.005	0.005	0.01	0.01	0.02
Hoop spacing > d/2			0.0	0.01	0.2	0.0	0.0	0.0	0.005	0.01
iv. Columns with axial loads exceeding 0.70P_o^{1, 3}										
Conforming hoops over the entire length			0.015	0.025	0.02	0.0	0.005	0.01	0.01	0.02
All other cases			0.0	0.0	0.0	0.0	0.0	0.0	0.0	0.0

1. When more than one of the conditions i, ii, iii, and iv occurs for a given component, use the minimum appropriate numerical value from the table.
2. "C" and "NC" are abbreviations for conforming and nonconforming transverse reinforcement. A component is conforming if, within the flexural plastic hinge region, hoops are spaced at ≤ d/3, and if, for components of moderate and high ductility demand, the strength provided by the hoops (V_s) is at least three-fourths of the design shear. Otherwise, the component is considered nonconforming.
3. To qualify, columns must have transverse reinforcement consisting of hoops. Otherwise, actions shall be treated as force-controlled.
4. Linear interpolation between values listed in the table shall be permitted.
5. For columns controlled by shear, see Section 6.5.2.4.2 for acceptance criteria.

The beam-column joints are modeled as rigid or as shear panels with shear force-shear angle relationships, shown on Figure 5.4.

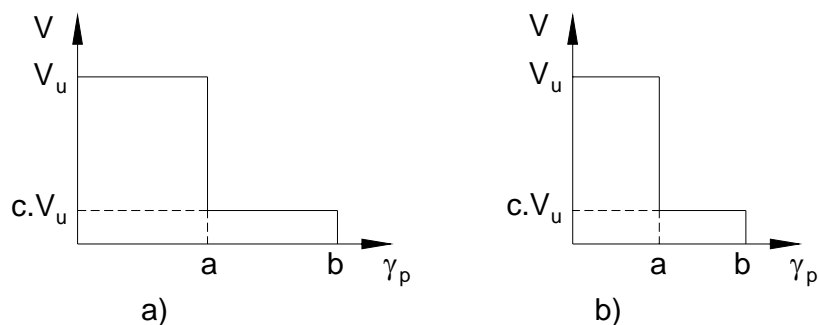

Figure 5.4. Typical joint $V-\gamma$ relationships: a) interior; b) other

Mean (expected) and mean minus one standard deviation (lower bound) strengths are used for modeling of ductile and brittle mechanisms respectively.

• *FEMA440- interpretation of the FEMA356 and ATC-40 models*

FEMA440 recognizes two kinds of strength degradation- cyclic and in-cycle (see Figure 5.5), since they have different effect on the structural response. The former phenomenon represents drop of resistance at given deformation level under consecutive loading cycles. The later phenomenon represents drop of resistance under monotonically increasing deformations.

The cyclic strength degradation effects are attributed to large inelastic deformations and are associated with ductile behaviour. The in-cycle strength losses are associated with brittle behaviour. Consequently, the constitutive laws for deformation-controlled and force-controlled actions in FEMA356 should be interpreted as backbone curves of the hysteretic responses of type a) and b) respectively (see Figure 5.5). In the latter case the backbone curve is essentially the same as the monotonic loading curve.

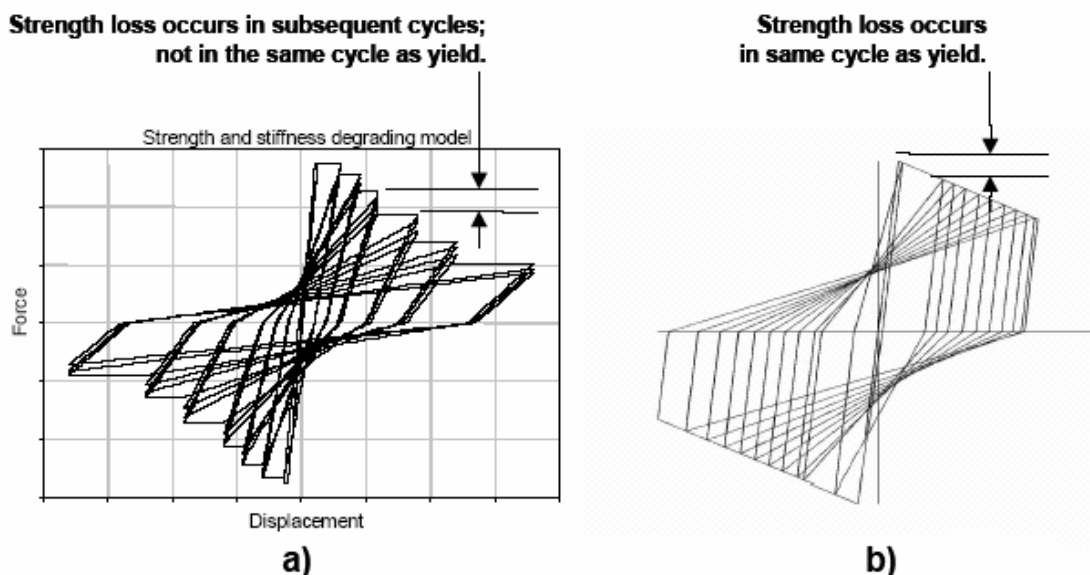

Figure 5.5. Types of strength degradation: a) Cyclic strength degradation; b) In-cycle strength degradation

- *Italian seismic code and EC8*

The two codes give general recommendations for modeling of primary and secondary components.

EC8 recommends the following expression for beam/column effective stiffness prior yielding:

$$(5.2) \quad EJ_{eff} = \frac{M_y L_{cl}}{\theta_y 2},$$

where M_y is the yield moment capacity of the end section, L_{cl} is the clear length and θ_y is the yield drift ratio of the element, considered as cantilever with length $L_{cl}/2$. The expression for θ_y accounts for steel strain penetration beyond the end section, flexural and shear deformations (see 6.4.1). EJ_{eff} is calculated for each half of every component.

According to the Italian seismic code the effective stiffness should not exceed 50% of the stiffness of the gross concrete section.

Mean strength values are applied for modeling of ductile mechanisms. Inelastic deformations, associated with brittle mechanisms, are not allowed (see 6.4.2).

- *Comparisons and comments*

All the codes recommend mean and less than mean strengths to be used for deformation-controlled and force-controlled actions respectively. In this way the analysis is conservative with respect to unfavorable brittle failure, since high strength estimates for ductile mechanisms mean high force demands on the non-ductile mechanisms in a yielding structure. At the same time, low capacity estimates are used for brittle failure modes.

5.2 Load vectors

The load vectors are obtained as a product of the floor masses and chosen profile of horizontal accelerations. They can be divided in two main groups: single-mode load vectors and multi-mode load vectors. In the former case, the push-over curve is generated by application of a single vector with constant or varying (adaptive) profile. In the latter case push-over analyses are carried out independently with load vectors representing the response in the first several modes and the effects are combined (multi-mode push-over procedures). The multi-mode push-over procedures are aimed to capture the higher mode participation in the response of the structure.

The single-mode load vectors are summarized below:

- Uniform (rectangular)- constant horizontal accelerations along the height of the structure;
- Triangular- linearly increasing accelerations from the base to the roof of the structure;
- Code distribution- varying from triangular to parabolic acceleration distribution according to the fundamental natural period of the structure (see 4.1.1.1);

- First mode- acceleration profile corresponding to the fundamental mode;
- Adaptive- uses the fundamental mode and recognizes the changes in the load pattern due to non-uniform softening of the structure with increasing control node displacement;
- SRSS- acceleration profile, generating the storey shear forces from LDP.

When the system has one degree of freedom, the load vector represents a single horizontal force.

- *FEMA356, ATC-40, Italian seismic code and EC8*

The load vectors, implemented in FEMA356, ATC-40, Italian seismic code (IC) and EC8 are given in Table 5.3.

Table 5.3 Load vectors

	Single-mode load vectors						Multi-mode load vectors
	Uniform	Triangular	Code distribution	First mode	Adaptive	SRSS	
FEMA356	√	–	√	√	√ ¹	√	–
ATC-40	–	–	√	√	√ ¹	–	√ ¹
IC	√	–	–	√	–	–	–
EC8	√	–	–	√	–	–	–

1- explicit instructions for implementation are not given.

- *FEMA440- evaluation of the load vectors*

FEMA440 examines the effectiveness of the load vectors adopted in FEMA356 and ATC-40 on nine example buildings. Each of the buildings is subjected to eleven ordinary ground motions and four near-field records. Each of the ordinary records is scaled through NDP to three intensity levels, resulting in three predefined total drifts (roof displacement as a percentage of the building height). The total drifts caused by the four near-field excitations are also obtained by NDP.

Each of the buildings is then pushed to the seven total drift levels, applying each of the load vectors. The distribution of the floor displacements, interstorey drifts, storey shears and overturning moments along the height of the structure are compared with the corresponding values from the non-linear dynamic analyses.

This analysis reveals the errors due to the load vector used, in case the target displacement (roof displacement) is well predicted. The first mode vector is recommended since it gives low error displacement estimates and keeps the consistency of the derivation of the ESDOF

system (see 5.4). The multi-mode push-over procedures should be used as a comparison or improvement over the single-mode load vectors. A need for future development of these procedures is pointed out.

5.3 Solution of SDOF systems

The force-displacement relation of a SDOF system is represented by its push-over curve, idealized as bi-linear (see Figure 5.6.a). The elastic and post-yield stiffness are denoted as k_0 and $\alpha_{\max}k_0$ respectively. All the codes (FEMA356, ATC-40, Italian seismic code and EC8) establish the bi-linear idealization on the principle for equal areas under the original and idealized push-over curves.

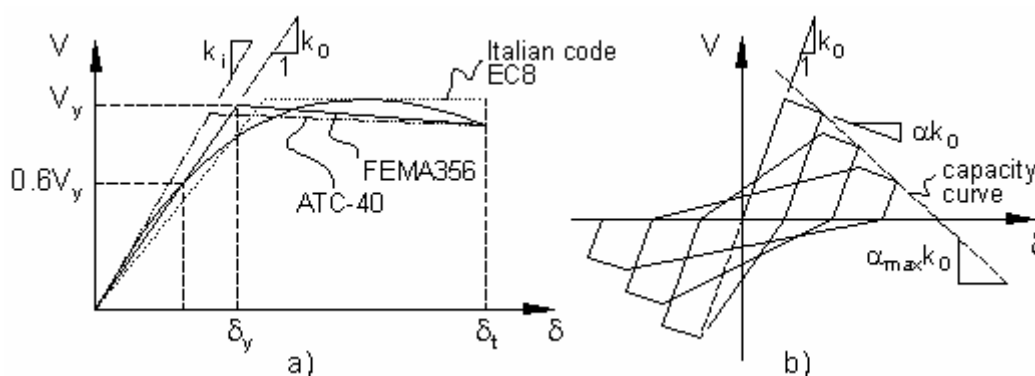

Figure 5.6. Capacity curve: a) bi-linear idealization; b) hysteretic model

The push-over curve actually represents a backbone curve of the expected global hysteretic response of the structure up to the target displacement. The model of the hysteretic response should generally include stiffness degradation, cyclic and in-cycle strength degradation (see Figure 5.6.b).

Theoretically, the system can be solved by direct integration of the equation of motion for fixed strength or fixed maximum ductility. The maximum mass displacement (target displacement) can be expressed as:

- fixed strength solution

$$(5.3) \quad \delta_{\max} = \delta_t = f(T_0, \beta_0, R, HYST, \alpha, a(t))$$

- fixed maximum ductility solution

$$(5.4) \quad \delta_{\max} = \delta_t = f(T_0, \beta_0, \mu, HYST, \alpha, a(t)).$$

The meaning of the governing parameters in the brackets is as follows:

- T_0 - natural period, corresponding to the elastic branch of the idealized push-over curve;
- β_0 - damping coefficient, usually given a value of 5%;

- $R = \frac{mS_a(T_0, \beta_0)g}{V_y}$ - strength ratio- maximum base shear due to elastic response over the base shear at yield (m is the mass of the system);
- μ - maximum ductility;
- *HYST*- parameters, modeling the stiffness and cyclic strength degradation;
- α - post-yield stiffness ratio (negative when in-cycle strength degradation is present);
- $a(t)$ - design accelerogram.

The solution for fixed ductility is iterative- the maximum ductility μ is varied until the strength ratio of the system is obtained.

The *HYST* and α parameters should model the global degradation effects (at “base shear - control node displacement” level), which are result of degradation behaviour at component level. Following the FEMA440 assumptions, the global in-cycle strength degradation is associated with development of brittle mechanisms and action of the gravity loads through the deformed configuration of the yielding structure, while the global cyclic strength degradation is essentially a consequence of development of ductile failure modes. Usually, the behaviour of the structure involves all the three phenomena. Based on the information from push-over analysis, *HYST* and α parameters can be only approximately predicted.

The static non-linear procedures propose close-form relations between the target displacement and the set of governing parameters in one of the two general forms:

$$(5.5) \quad \delta_t = \left(S_a(T_0, \beta_0) \frac{T_0^2}{4\pi^2} g \right) C_1 C_2 C_3 \quad \text{or}$$

$$(5.6) \quad \delta_t = S_a(T_{eff}, \beta_{eff}) \frac{T_{eff}^2}{4\pi^2} g.$$

The excitation is represented by design elastic pseudo-acceleration response spectrum $S_a(T, \beta)$. In this way, the target displacement has meaning of design displacement.

The first approach (eq. (5.5)) is called Displacement Modification Technique, since the target displacement is obtained by modification of the maximum displacement of the elastic system (in brackets) by factors C_i to account for yielding (C_1), stiffness and cyclic strength degradation (C_2), in-cycle post-yield hardening/degradation (C_3) (see Figure 5.7).

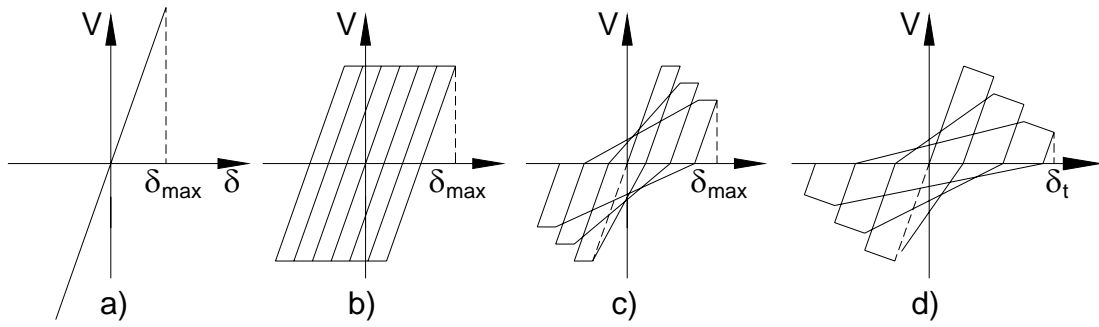

Figure 5.7. Displacement Modification Technique: a) $\delta_{\max} = S_d(T_0)$; b) $\delta_{\max} = S_d(T_0)C_1$; c) $\delta_{\max} = S_d(T_0)C_1C_2$; d) $\delta_t = S_d(T_0)C_1C_2C_3$

The approach uses formulation (5.3) and consequently the modification coefficients C_i should ideally depend on:

$$(5.7) \quad C_1 = f(T_0, R, \text{excitation_characteristics})$$

$$(5.8) \quad C_2 = f(T_0, R, \text{HYST}, \text{excitation_characteristics})$$

$$(5.9) \quad C_3 = f(T_0, R, \text{HYST}, \alpha, \text{excitation_characteristics}).$$

C_1 should have values close to unity for long-period structures based on the widely adopted equal-displacement principle.

It can be expected that long-duration records and short period structures would result in higher values of C_2 as compared to near-field records and long-period structures. C_2 should also increase with increasing magnitude of inelastic deformations, i.e. increasing strength reduction factor R .

In general, C_3 should have values less than unity for positive values of α and higher than unity for negative values of α , reflecting the favourable effect of post-yield hardening and the unfavourable effect of in-cycle strength degradation.

The second approach (eq. (5.6)) is called Equivalent Linearization Technique, since the original system is substituted with linear system, which has natural period T_{eff} and damping ratio β_{eff} . The two systems are equivalent with respect to the maximum displacement (target displacement). Usually, the pseudo-acceleration response spectrum $S_a(T, \beta_{\text{eff}})$ is obtained from the 5%-damped spectrum $S_a(T, \beta_0)$ using reduction factor with values depending on β_{eff} .

The approach uses formulation (5.4). Consequently, it is iterative and the properties of the linear system should depend on all the governing parameters:

$$(5.10) \quad T_{\text{eff}} = f(T_0, \mu, \text{HYST}, \alpha, \text{excitation_characteristics})$$

$$(5.11) \quad \beta_{\text{eff}} = f(T_0, \mu, \text{HYST}, \alpha, \text{excitation_characteristics}).$$

Intuitively, the structure softens (T_{eff} decreases) and the energy dissipation increases (β_{eff} increases) with increasing inelastic deformations, i.e. with increasing ductility μ .

Expressions (5.5) and (5.6) can be written also as:

$$(5.12) \quad \mu = R C_1 C_2 C_3 \quad \text{and}$$

$$(5.13) \quad R = \frac{S_a(T_0, \beta_0)}{S_a(T_{eff}, \beta_{eff})} \frac{T_0}{T_{eff}} \mu,$$

respectively. This form is convenient because it allows for direct comparison with the commonly adopted principles for design of new buildings, namely equal energy and equal displacement principles:

$$(5.14) \quad \mu = \frac{R^2 + 1}{2} \quad \text{- for short period structures;}$$

$$(5.15) \quad \mu = R \quad \text{- for long period structures.}$$

. It can be seen again that the Equivalent Linearization Technique results in iterative procedure since the ductility demand μ is not known in advance, while the force reduction factor R can be easily calculated.

The exposed general scheme of the static non-linear procedures in the case of SDOF systems is used in the following paragraphs for interpretation of the code procedures.

- *FEMA356 - Displacement Coefficient Method (DCM)*

The Displacement Coefficient Method (DCM) is based on (5.5). The modification coefficients in FEMA356 are aimed to account for yielding (C_1), stiffness and strength degradation (C_2), dynamic P- Δ effects (C_3) (see Figure 5.8.a) and are given by the following expressions:

$$(5.16) \quad C_1 = \begin{cases} 1.0 & \text{for } T_0 \geq T_s \\ 1.0 + (R-1) \frac{T_s}{T_0} & \text{for } T_0 < T_s \\ \frac{1.0 + (R-1) \frac{T_s}{T_0}}{R} & \text{for } T_0 < T_s \end{cases},$$

but not more than

$$(5.17) \quad \begin{cases} 1.5 & \text{for } T_0 < 0.1s \\ 1.0 & \text{for } T_0 \geq T_s \end{cases}$$

with linear interpolation in the interval $T_0=0.1 \div T_s$, where T_s is the transitional period between the constant acceleration and constant velocity regions of the pseudo-acceleration response spectrum.

$$(5.18) \quad C_2 = f(T_0/T_s; \text{performance level}; \text{framing type})$$

with the largest value of 1.5 for $T_0 \leq 0.1s$ and CP performance level, and the smallest value of 1.0 for $T_0 \geq T_s$ and IO PL. Alternatively, $C_2=1$ can be adopted.

$$(5.19) C_3 = 1.0 + \frac{|\alpha_{\max}|(R-1)^{3/2}}{T_0}$$

if the post-yield stiffness is negative. Otherwise, $C_3=1$ should be used.

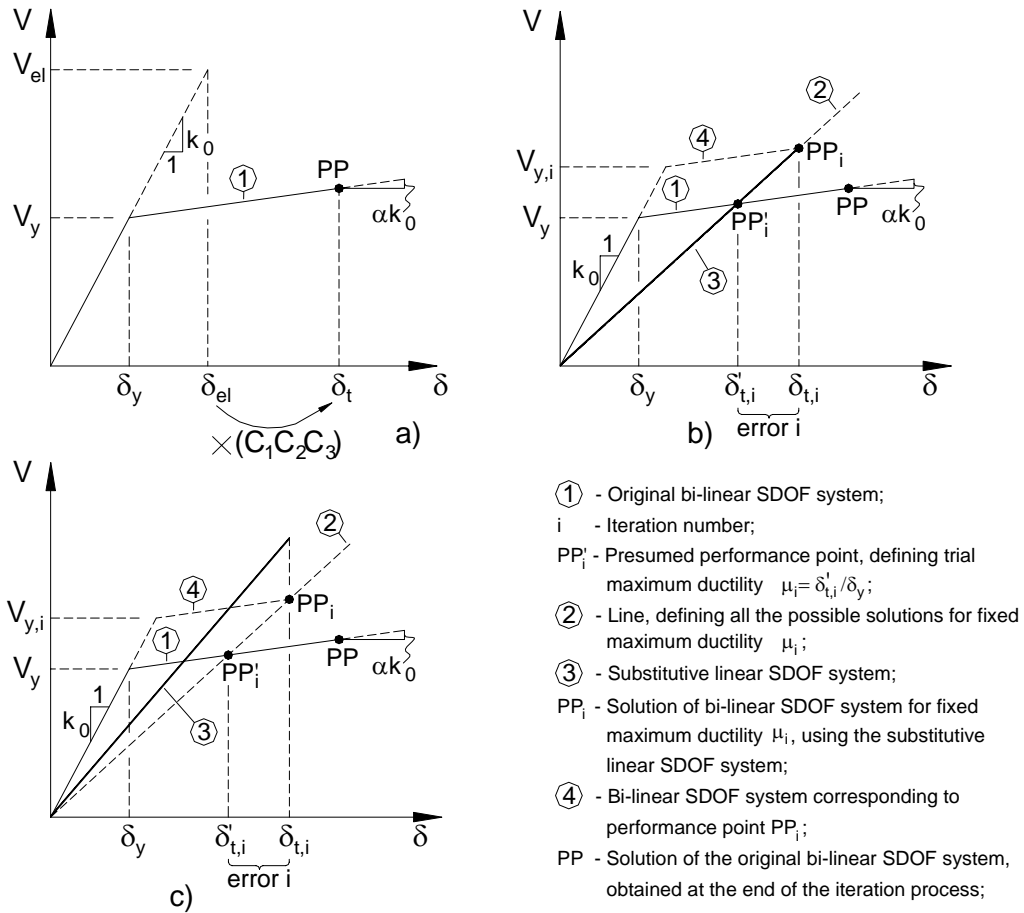

Figure 5.8. Non-linear static procedures: a) DCM acc. to FEMA356; b) CSM acc. to ATC-40; c) CSM acc. to FEMA440

The equal displacement principle applies to structures with fundamental period T_0 in the constant velocity region of the response spectrum (see (5.16)). The maximum displacement of short period structures increases with decreasing T_0/T_s ratio.

Assuming that C_2 coefficient accounts for stiffness and cyclic strength degradation, C_3 coefficient should account for the amplification of the maximum displacement due to in-cycle degradation and should not be associated with P- Δ effects only (acc. to FEMA440 the brittle mechanisms also contribute to the in-cycle strength loss). Following these assumptions, C_3 should depend on α rather than on α_{\max} . (see Figure 5.6). The expression (5.19) implies that the structure does not exhibit cyclic strength degradation ($\alpha \equiv \alpha_{\max}$), which is in contradiction with the non-unity values of C_2 .

According to (5.18), the effect of stiffness and cyclic strength degradation are more pronounced for short period structures. C_2 depends on the performance level under consideration instead on the strength reduction factor R (see (5.8)). Nonetheless, the expected

tendency is kept: the more damage is accepted (larger magnitudes of inelastic deformations), the larger the effect of stiffness and cycle strength degradation. Expression (5.18) also shows that according to FEMA356 each type of framing system has inherent pattern of degradation. The influence of the excitation duration on C_2 is not directly accounted for.

The favourable effect of post-yield hardening is neglected ($C_3=1$ when $\alpha_{\max}>0$). FEMA356 imposes additional limitation, related to the dynamic P- Δ effects (the case of $\alpha_{\max}<0$): the base shear at the target displacement should not be less than 80% of the maximum base shear developed, i.e. the total resistance degradation is limited to 20%. Beyond that point the results are expected to be very sensitive.

- *ATC-40- Capacity Spectrum Method (CSM)*

The Capacity Spectrum Method (CSM) is based on (5.6).

The expressions for the natural period and damping ratio of the substitutive linear system are given as:

$$(5.20) \quad T_{\text{eff}} = T_0 \sqrt{k_0 / k_{\text{eff}}} = T_0 f(\mu, \alpha_{\max}) = T_0 \sqrt{\frac{\mu}{1 + \alpha_{\max} \mu - \alpha_{\max}}},$$

$$(5.21) \quad \beta_{\text{eff}} = \beta_0 + k \beta_e(\mu, \alpha_{\max}) = 0.05 + k \frac{2(\mu - 1)(1 - \alpha_{\max})}{\pi \mu (1 + \alpha_{\max} \mu - \alpha_{\max})},$$

where μ is presumed maximum ductility, based on trial target displacement (see Figure 5.8.b).

The effective period T_{eff} corresponds to the secant stiffness k_{eff} through the performance point and increases with increasing magnitude of inelastic deformations. It does not depend on the stiffness and cycle strength degradation properties of the structure. The excitation characteristics are not reflected either.

The damping ratio β_e leads to equal energy dissipation of a spring-damper system with stiffness k_{eff} and the bi-linear spring in one cycle of harmonically imposed displacement with frequency ω_{eff} and amplitude δ . It is assumed that the unloading and reloading branches of the bi-linear spring are parallel to the elastic branch. The factor k is a measure of the extent to which the actual building hysteresis is well represented by the regular loop, i.e. it accounts for stiffness and cyclic strength degradation. Consequently, it could be written in the following general form:

$$(5.22) \quad k = f(T_0, \mu, \text{HYST}, \text{excitation_characteristics}).$$

The lower the k is, the higher the target displacement.

According to ATC-40, k depends on $\beta_e(\mu, \alpha_{\max})$ and the behaviour type of the system (A, B or C), which in turn depends on the quality of the seismic resisting system (essentially new, average existing or poor existing) and the duration of ground shaking (short or long) (see Table 5.4). Therefore, ATC-40 relates the degradation pattern of the structure to the quality of

its earthquake resisting system. Reasonably, the ground-shaking duration is the excitation parameter, governing the degradation effects.

k decreases with increasing excitation duration and magnitude of inelastic deformations. The lower is the quality of the resisting system, the lower the k (see Figure 5.9).

Table 5.4 Structural behaviour types

Shaking Duration	Essentially New Building	Average Existing Building	Poor Existing Building
Short	Type A	Type B	Type C
Long	Type B	Type C	Type C

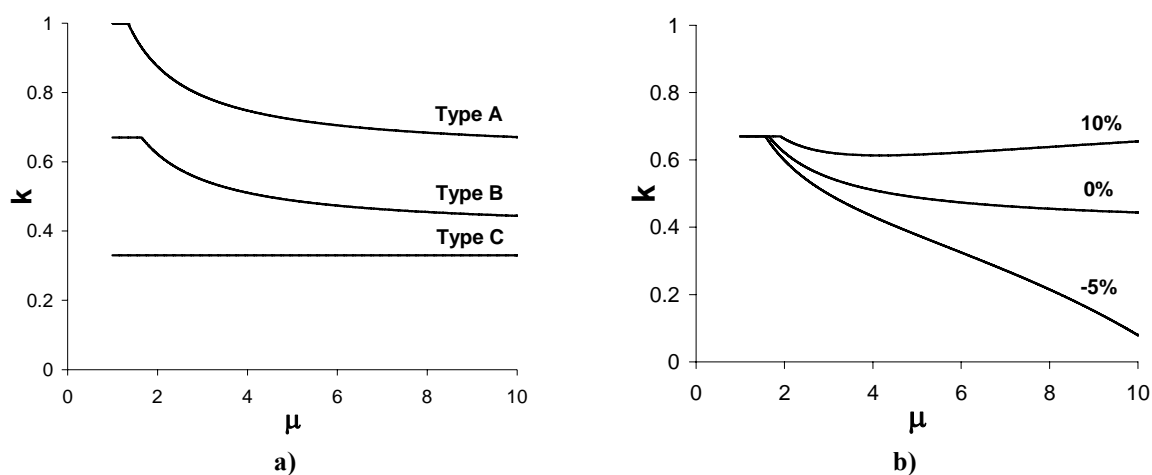

Figure 5.9. ATC-40- degradation effects: a) Influence of the quality of the seismic resistance system; b) Influence of the post-yield stiffness ratio α_{max}

ATC-40 adopts $\alpha \equiv \alpha_{max}$, leading to similar contradiction to those in FEMA356 (see the previous point).

The reduced spectrum $S_a(T, \beta_{eff})$ is obtained from the 5%-damped spectrum by division with factors $B_S(\beta_{eff}) \geq 1$ and $B_L(\beta_{eff}) \geq 1$ in the constant acceleration and constant velocity region respectively. B_S and B_L have upper limits, depending on the building behaviour type, because of the strength and stiffness degradation uncertainties.

The solution can be conveniently presented in an Acceleration Displacement Response Spectrum (ADRS) coordinate system, since the performance point is obtained by intersection of the reduced ADRS and straight line radiating from the origin, representing a structure with period T_{eff} (see Figure 5.10).

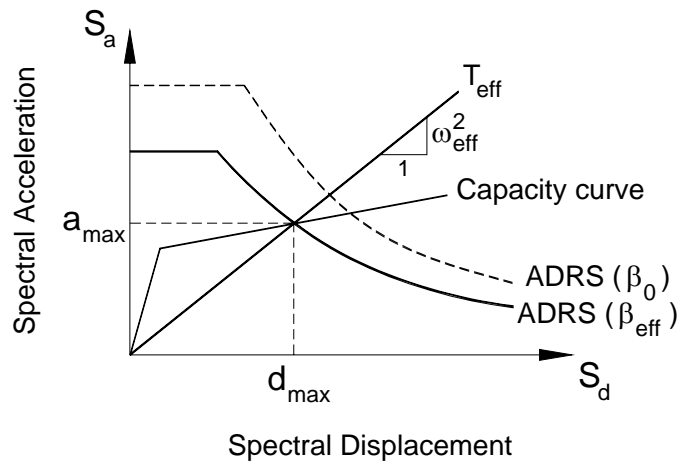

Figure 5.10. CSM- Solution in ADRS coordinate system

- *FEMA440- evaluation of the FEMA356 Displacement Coefficient Method (DCM) and ATC-40 Capacity Spectrum Method (CSM)*

About 180 000 non-linear dynamic analyses of SDOF systems are carried out, varying the following governing parameters:

- natural period T_0 ;
- strength ratio R ;
- ground motion record- 100 records, divided into five groups according to the site conditions;
- hystretic model *HYST* and α (see Figure 5.11)- elastic-perfectly plastic (EPP), stiffness degrading (SD), stiffness and cyclic strength degrading (SSD), stiffness and in-cycle strength degrading (STRDG), non-linear elastic (NE).

The maximum displacements, obtained by these analyses, are used as a benchmark for evaluation of the DCM and CSM.

The DCM is evaluated, as the mean error for each group of records, associated with each of the coefficients C_i , is plotted against the natural period for fixed strength ratio. In the case of C_3 , the parameter α is also included, to reflect the in-cycle strength degradation. The C_i benchmarks are calculated according to (5.5):

$$(5.23) C_1 = \delta_{\max}^{EPP} / \delta_{\max}^{el}$$

$$(5.24) C_2 = \delta_{\max}^{SD} / \delta_{\max}^{EPP} \text{ and } \delta_{\max}^{SSD} / \delta_{\max}^{EPP}$$

$$(5.25) C_3 = \delta_{\max}^{STRDG} / \delta_{\max}^{SD}$$

although there is no clear division of the intent of the coefficients C_2 and C_3 in FEMA356.

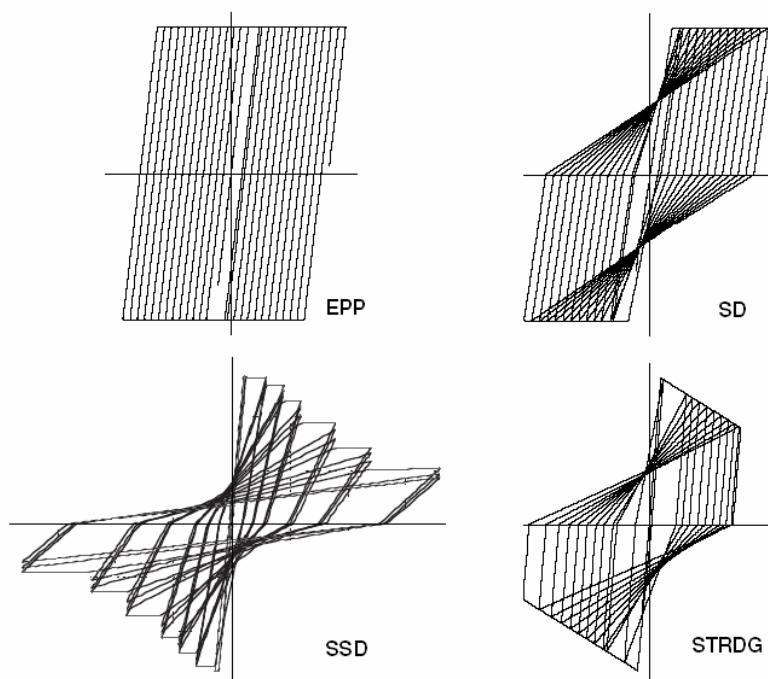

Figure 5.11. Types of hysteretic behaviour, used for evaluation of FEMA356 DCM and ATC-40 CSM

The results for C_1 show, that the transition period, after which the equal displacement principle applies, is larger than T_s (see (5.16)) and is approximately equal to 1.0s. The “capping” (5.17) on the C_1 values makes the maximum displacements of EPP system practically independent on the strength ratio for periods less than T_s , which is not confirmed by the dynamic analyses. According to FEMA440, the limitations (5.17) are intended to reflect some soil-structure interaction aspects, leading to reduced inelastic demands for stiff structures. The influence of the strength ratio on C_1 coefficient is not well predicted also when (5.16) is used without “capping”.

According to the dynamic analyses, the maximum displacement of systems with period more than approximately 0.8s is almost unaffected by stiffness and cyclic strength degradation, while FEMA356 gives values of C_2 equal to 1.0 for IO, 1.1 for LS PL and 1.2 for CP PL. In the short period range the DCM in general underestimates the degradation effects.

It is observed, that C_3 coefficient has value of approximately unity up to certain strength ratio for given natural period and negative post-yield stiffness ratio. Beyond this value, the in-cycle degradation rapidly increases the maximum displacement. Velocity pulses, typical for near-field excitations, can amplify this dynamic instability effect, driving the structure far into the inelastic range in a single deformation cycle. Expression (5.19) does not reflect these observations (see Figure 5.12.a). The limitation of the total resistance loss to maximum 20% in FEMA356 is not discussed in FEMA440 as a possible assessment of the dynamic stability of the structure.

The evaluation of the CSM is done by plotting the mean target-displacement error for a given group of records against the natural period for fixed strength ratio and hysteretic model. Hysteretic models EPP, SD and SSD are used for buildings of behaviour types A, B and C

respectively. The results show, that the CSM leads to very large overestimations of the maximum displacement for relatively short-period structures (natural periods smaller than about 0.5s).

The CSM does not capture adequately the dynamic instability effects as shown in Figure 5.12.b. The curves are obtained through (5.13) for $T_0=0.6s$, system behaviour type B, $T_s=0.5s$ and $|S_a(T, \beta_0)|_{\max}=3 \times \text{PGA}$. Rapid increase of ductility demand is in fact observed, but it occurs at very high values of strength reduction factor R . Figure 5.12.b also demonstrates that, in some cases, the CSM does not provide unique solution.

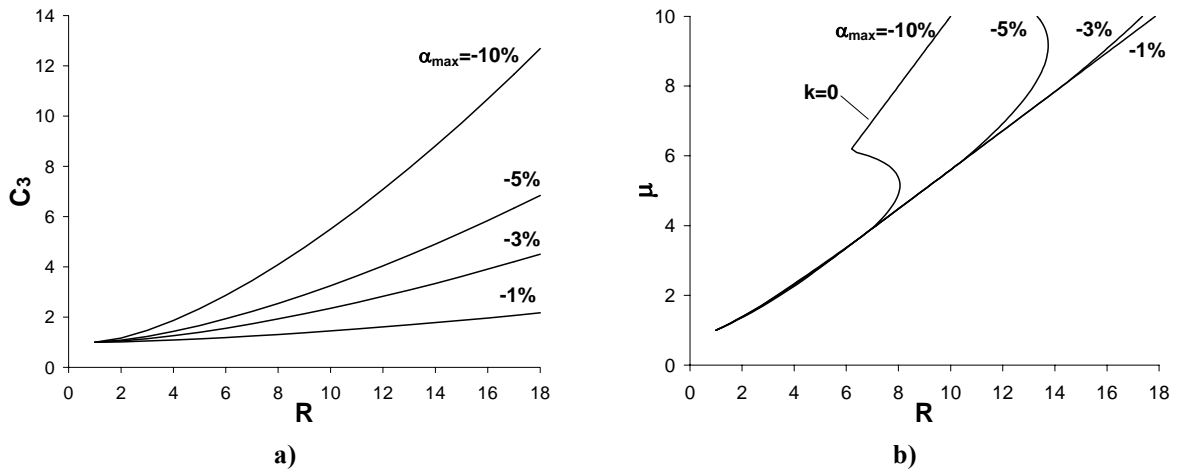

Figure 5.12. Dynamic instability: a) FEMA356 DCM for $T_0=0.6s$; b) ATC-40 CSM

- *FEMA440- improved Displacement Coefficient Method (DCM) and Capacity Spectrum Method (CSM)*

Based on numerous non-linear dynamic analyses carried out, FEMA440 suggests improved versions of the FEMA356 DCM and ATC-40 CSM.

In the improved DCM, the coefficients C_1 , C_2 and C_3 have the definition given in (5.5) (see also (5.23), (5.24) and (5.25)) with some simplifications. C_2 is based on hysteretic model with stiffness degradation only (SD), i.e. the influence of the cyclic strength degradation on the target displacement is neglected. The degradation model is fixed and is not related to the type or quality of the bracing system. Also neglected is the positive effect of possible post-yield hardening ($\alpha_{\max} > 0$).

FEMA440 gives the following improved expressions for the coefficients C_1 and C_2 :

$$(5.26) \quad C_1 = 1 + \frac{R-1}{aT_0^2} \begin{cases} \leq C_1(T_0 = 0.2s) \\ = 1.0 \text{ if } T_0 \geq 1s \end{cases}$$

where $a=f(\text{site class})$.

$$(5.27) \quad C_2 = 1 + \left(\frac{R-1}{T_0} \right)^2 \begin{cases} \leq C_2(T_0 = 0.2s) \\ = 1.0 \text{ if } T_0 \geq 0.7s \end{cases}$$

The “capping” (5.17) on C_1 values is omitted, since FEMA440 proposes rational procedure for consideration of the soil-structure interaction.

The coefficient C_3 is replaced with dynamic stability check, which is essentially verification for sufficient strength:

$$(5.28) R \leq R_{\max} = 1 + \frac{|\alpha|^{-(1+0.15 \ln T_0)}}{4}.$$

It could be assumed that (5.28) is obtained by limiting C_3 to values close to unity:

$$(5.29) C_3 = f(T_0, R, HYST, \alpha, excitation_characteristics) \leq a \approx 1.$$

The susceptibility of the structure to dynamic instability increases with increasing post-yield stiffness ratio α and natural period T_0 (see Figure 5.13.a). In other words, the “sharper” is the idealized push-over curve (increasing k_0 for fixed α or vice versa), the higher the vulnerability of the system. The influence of the excitation type (far- or near-field) is not explicitly reflected in (5.28).

If (5.28) is not observed, non-linear dynamic procedure should be used for investigation of the potential dynamic instability.

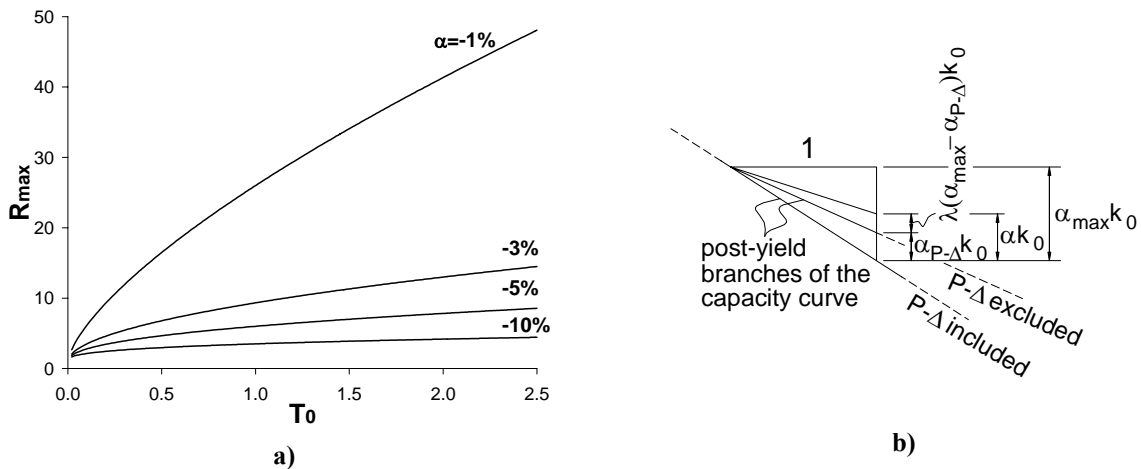

Figure 5.13. Dynamic stability: a) maximum strength ratio; b) in-cycle degradation stiffness ratio

FEMA440 proposes approximate evaluation of the post-yield stiffness ratio α (see Figure 5.13.b):

$$(5.30) \alpha = \alpha_{P-\Delta} + \lambda(\alpha_{\max} - \alpha_{P-\Delta})$$

where:

- λ - equal to 0.8 for sites subjected to near field effects and 0.2 for sites not subjected to near field effects;

- $\alpha_{P-\Delta}$ - the portion of the post-yield stiffness ratio α_{\max} , associated with P- Δ effects.

The terms $\alpha_{P-\Delta}$ and $\lambda(\alpha_{\max}-\alpha_{P-\Delta})$ can be associated with in-cycle degradation due to P- Δ effects and due to development of brittle failure modes respectively. The values of λ imply conservatism in the case of near-field excitations.

The improved CSM considers solution of systems with one of the following three hysteretic models: bilinear hysteretic (BLH), stiffness degrading (STDG), and stiffness and in-cycle strength degrading (STRDG) (see Figure 5.14). The post-yield stiffness ratio α varies from 0 to 20% for BLH and STDG, and from -5 to -3% for STRDG model. The cyclic strength degradation effects are not considered.

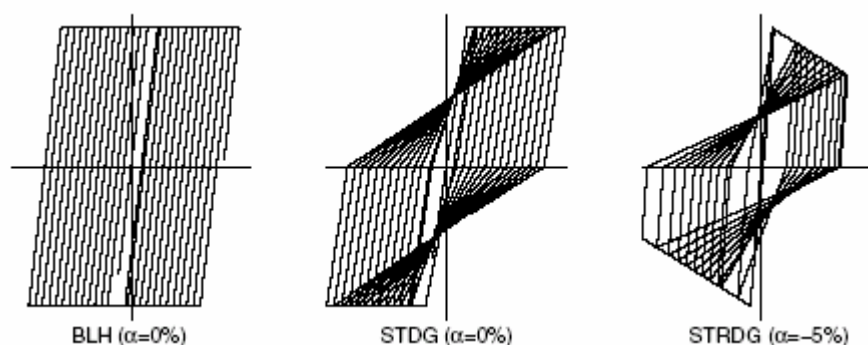

Figure 5.14. Types of hysteretic behaviour, considered by the improved CSM

FEAM440 does not associate the three hysteretic models with particular type of structures. The engineer should select the behaviour type, fitting best to the retrofitting building, or otherwise, conservative expressions, that are not dependent on the hysteretic type and alpha value, can be used. In the former case, the expression (5.30) can be used for approximate evaluation of the in-cycle degradation stiffness ratio.

A new linearization approach is proposed for improvement of the ATC-40 CSM. For this reason, an error measure is defined as:

$$(5.31) \quad \varepsilon = \frac{\delta_{lin}(T_{eff}, \beta_{eff}, a(t)) - \delta_{nlin}(T_0, \beta_0, \mu, HYST, \alpha, a(t))}{\delta_{nlin}(T_0, \beta_0, \mu, HYST, \alpha, a(t))} 100\%$$

where δ_{lin} and δ_{nlin} are the maximum displacements of given substitutive and non-linear systems respectively, for given ground motion. The error is negative, when the substitutive system underestimates the peak displacement.

The optimum substitutive system (T_{eff}, β_{eff}) for given non-linear system ($T_0, \beta_0, \mu, HYST, \alpha$) and the selected 100 records, is defined as the system, which minimizes the probability that the error ε is outside the range $-10\% \div 20\%$, called Engineering Acceptability Range. In this case, the effective period T_{eff} does not correspond to the secant period T_{sec} , but is in general less than it (see Figure 5.8.c).

The general form of the obtained expressions is:

$$(5.32) \quad T_{eff} = f(\mu, HYST, \alpha)T_0$$

$$(5.33) \beta_{eff} = \beta_0 + f(\mu, HYST, \alpha).$$

The B_L and B_S coefficients, used for evaluation of the reduced spectrum $S_a(T, \beta_{eff})$ are replaced with coefficient B :

$$(5.34) B = \frac{4}{5.6 - \ln \beta_{eff}}$$

No upper limit for the reduction coefficient B is used, since the code gives procedure for evaluation of the maximum displacement of systems with predefined hysteretic models (see Figure 5.14), rather than solution of real structures with uncertain hysteretic behaviour.

Although the in-cycle strength degradation effects are accounted for in (5.32) and (5.33) through the parameter α , the dynamic instability check (5.28) should be performed.

In the exposed linearization procedure, the intersection point of the $ADRS(\beta_{eff})$ and the straight line, representing the substitutive structure, does not represent the performance point, since $k_{eff} \neq k_{sec}$. Its abscissa corresponds to the target displacement, while its ordinate is not meaningful (see Figure 5.15). The ordinate can be adjusted by using Modified $ADRS$ ($MADRS$) instead the $ADRS(\beta_{eff})$:

$$(5.35) MADRS(\beta_{eff}, M) = M \times ADRS(\beta_{eff}),$$

where:

$$(5.36) M = \left(\frac{T_{eff}}{T_{sec}}\right)^2 = \left(\frac{T_{eff}}{T_0}\right)^2 \left(\frac{T_0}{T_{sec}}\right)^2 = f(\mu, HYST, \alpha) \frac{k_{sec}}{k_0}.$$

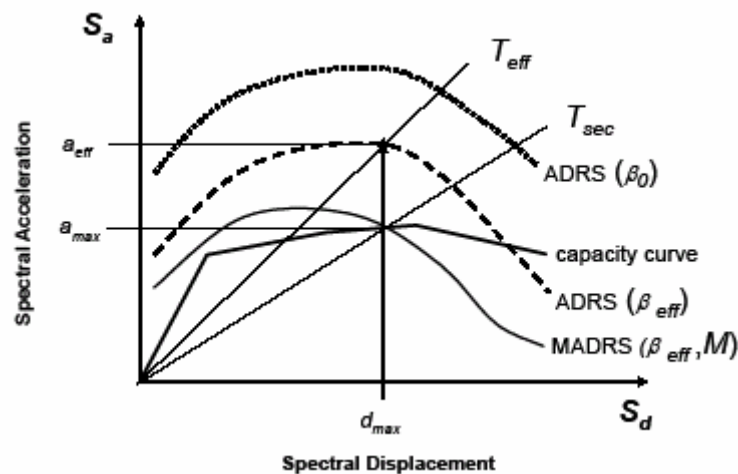

Figure 5.15. Improved CSM- Solution in ADRS coordinate system

- *Italian seismic code and EC8*

The evaluation of the target displacement according to the Italian seismic code and EC8 is based on (5.5). The expression for C_1 is the same as in FEMA356 (see Eq. (5.16)). Coefficients C_2 and C_3 are given values 1. No dynamic stability check is included.

EC8 imposes upper limit to C_1 (“capping”), equal to 3.

- *Comparisons and comments*

The Displacement Modification Technique is implemented in FEMA356, Italian seismic code and EC8, while the Equivalent Linearization Technique- in ATC-40. FEMA440 proposes improved versions of both approaches.

FEMA356 and ATC-40 procedures (DCM and CSM respectively) account for stiffness, cyclic and in-cycle strength degradation. FEMA356 relates the pattern of stiffness and cyclic strength degradation to the type of framing system, while ATC-40- to its quality.

FEMA440 neglects the cycle strength degradation effects and gives two options for stiffness degradation: no degradation or degradation with fixed pattern, as the choice is up to the engineer. The dynamic stability of the structure, related to in-cycle strength degradation, is verified.

According to FEMA440, the procedures implemented in FEMA356 and ATC-40 are not able to adequately capture the dynamic instability phenomenon. However, the limit on the drop of resistance of the structure, imposed in FEMA356, has not been considered. It can be expressed as:

$$(5.37) \quad \frac{V_y - V(\delta_t)}{V_y} = \alpha(\mu - 1) \leq 0.2.$$

Considering (5.12) and (5.37):

$$(5.38) \quad \frac{V_y - V(\delta_t)}{V_y} = \alpha(R.C_1.C_2.C_3 - 1) \leq 0.2.$$

Inequality (5.38) allows the limit on the drop of resistance to be transformed into limit on the strength ratio ($R < R_{\max}$). The results are shown in Figure 5.16 for $T_s=0.5s$ and $C_2=1$ together with the FEMA440 values (eq.(5.28)). The graphs illustrate that the FEMA356 procedure is conservative in comparison to that in FEMA440.

It can be assumed that C_3 increases rapidly with R when R is larger than R_{\max} . This is demonstrated in (5.17) for $T_0=0.6s$, $T_s=0.5s$ and $C_2=1$.

The Italian seismic code and EC8 assume that the structure behaves as elastic-perfectly plastic and do not account for stiffness and cycle strength degradation effects. It seems that this simplification leads to underestimation of the target displacement. It should be pointed out however, that the procedure for bi-linear idealization, applied in the two codes, generally results in lower stiffness k_0 as compared to the procedure in FEMA356 (see Figure 5.6). More worrying is the fact that the Italian seismic code and EC8 do not recognize the dynamic instability phenomenon.

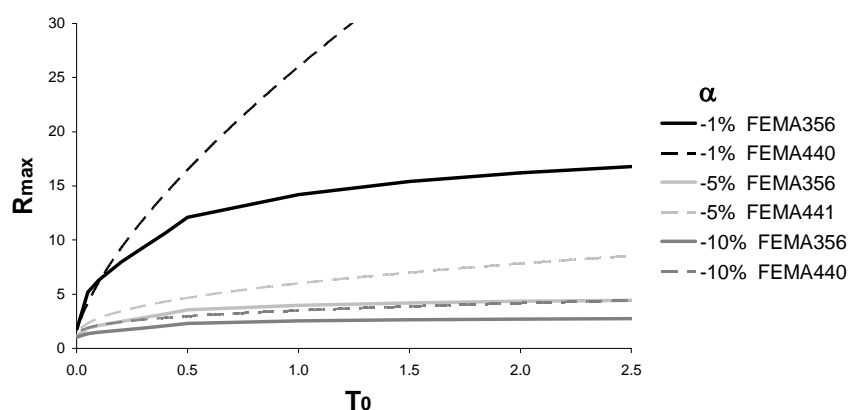
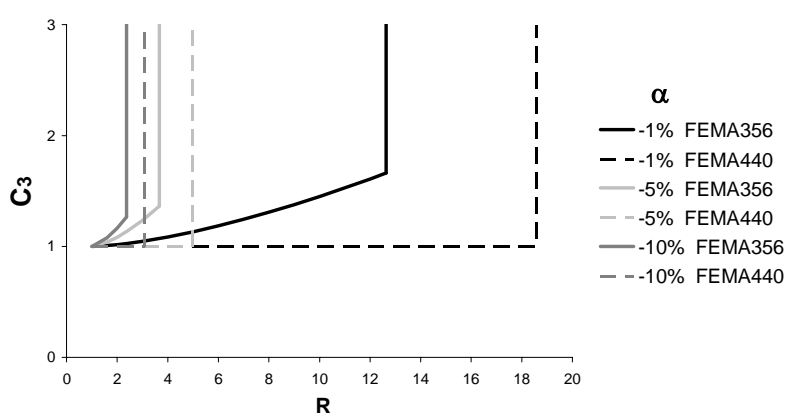

Figure 5.16. Maximum strength ratio according to FEMA356 and FEMA440

 Figure 5.17. C_3 coefficient according to FEMA356 and FEMA440

5.4 Solution of MDOF systems

The horizontal motion of the floor lumped masses of a non-linear MDOF system, following the slow application of the gravity loads, can be described by the non-linear simultaneous equations:

$$(5.39) \quad [m]\{\ddot{u}\} + [c]\{\dot{u}\} + f_s(\{u\}, \text{sign}\{\dot{u}\}) = -[m]\{1\}a(t),$$

where:

- $\{\ddot{u}\}, \{\dot{u}\}, \{u\}$ - horizontal accelerations, velocities and displacements of the floor masses;
- $[m]$ and $[c]$ - mass and damping matrixes;
- $f_s(\{u\}, \text{sign}\{\dot{u}\})$ - restoring forces, reflecting material and geometric nonlinearities;
- $a(t)$ - design accelerogram.

It is assumed that the deformation pattern of the structure does not change during the response:

$$(5.40) \quad \{u\} = \{\phi\}\Gamma.\Delta(t),$$

where $\{\phi\}$ is the chosen pattern and

$$(5.41) \quad \Gamma = \frac{\{\phi\}^T [m] \{1\}}{\{\phi\}^T [m] \{\phi\}}.$$

This assumption essentially reduces the degrees of freedom from n (number of floors) to one. In reality the deformed shape varies, especially when inelastic deformations develop in a non-uniform way along the height of the building.

The expression (5.40) is substituted in (5.39) and each term of the obtained simultaneous equations is premultiplied by $\{\phi\}^T / (\Gamma \{\phi\}^T [m] \{\phi\})$, resulting in:

$$(5.42) \quad \ddot{\Delta} + \frac{\{\phi\}^T [c] \{\phi\}}{\Gamma \{\phi\}^T [m] \{\phi\}} \dot{\Delta} + \frac{\{\phi\}^T f_s(\Delta, \text{sign} \dot{\Delta})}{\Gamma \{\phi\}^T [m] \{\phi\}} = -a(t),$$

This equation can be rewritten as:

$$(5.43) \quad \ddot{\Delta} + \frac{c^*}{m^*} \dot{\Delta} + \frac{F_s(\Delta, \text{sign} \dot{\Delta})}{m^*} = -a(t)$$

where:

$$(5.44) \quad m^* = \Gamma \{\phi\}^T [m] \{\phi\} = \{\phi\}^T [m] \{1\};$$

$$(5.45) \quad c^* = \{\phi\}^T [c] \{\phi\};$$

$$(5.46) \quad F_s(\Delta, \text{sign} \dot{\Delta}) = \{\phi\}^T f_s(\Delta, \text{sign} \dot{\Delta}).$$

The relation F_s - Δ under monotonically increasing parameter Δ can be obtained by subjecting the structure to imposed displacements according to (5.40) and calculating the right hand side of (5.46) at each displacement step. Alternatively:

$$(5.47) \quad F_s = V / \Gamma \quad \text{and}$$

$$(5.48) \quad \Delta = \delta / \Gamma \phi_{CN},$$

where V - δ is a push-over curve, obtained by subjecting the structure to a load vector with shape $[m] \{\phi\}$. Usually, the deformed shape $\{\phi\}$ is normalized to unit control node value ($\phi_{CN}=1$).

Expressions (5.47) and (5.48) follow from an assumption that the restoring forces f_s are proportional to $[m] \{\phi\}$ (see Figure 5.18):

$$(5.49) \quad V = \{\phi\}^T [m] \{1\} k = \Gamma \{\phi\}^T [m] \{\phi\} k \approx \Gamma F_s$$

$$(5.50) \quad \delta \approx \phi_{CN} \Gamma \Delta$$

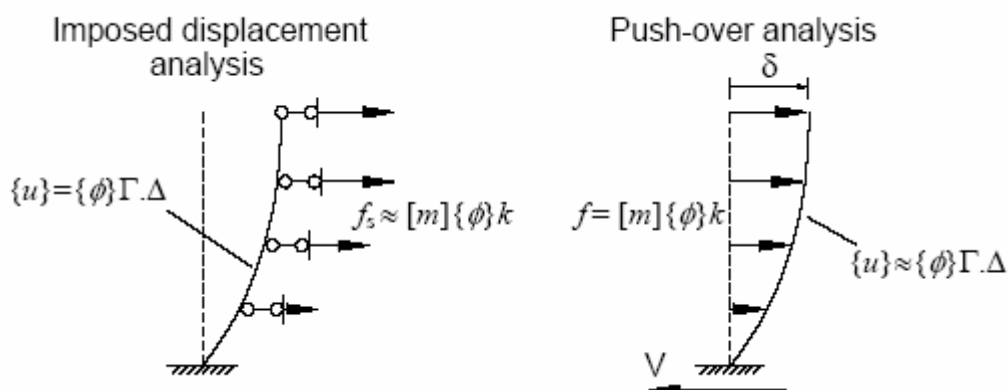

Figure 5.18. Imposed displacements analysis and push-over analysis

Equation (5.43) represents equation of motion of the Equivalent SDOF system, defined by mass m^* , damping coefficient c^* and non-linear spring $F_S(\Delta, sign\dot{\Delta})$ (see Figure 5.19). The maximum displacement of the ESDOF system Δ_{max} can be calculated by the procedures for SDOF systems (see 5.3). Once the non-linear spring is idealized as bi-linear, the damping coefficient can be expressed as:

$$(5.51) \quad c^* = 2m^* \omega_0 \beta_0,$$

where $2m^* \omega_0$ is the critical damping coefficient of the system, corresponding to the elastic branch of the idealized $F_S-\Delta$ relation. Usually, the damping ratio β_0 is given value 5%.

Considering (5.43) and (5.51):

$$(5.52) \quad \ddot{\Delta} + 2\beta_0 \omega_0 \dot{\Delta} + \frac{F_S(\Delta, sign\dot{\Delta})}{m^*} = -a(t)$$

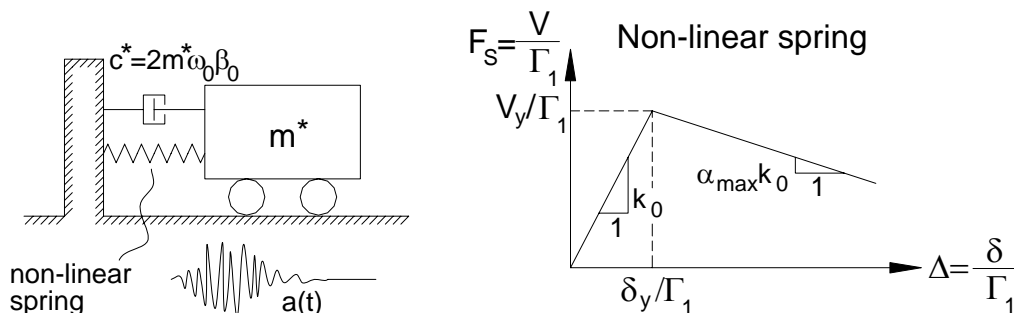

Figure 5.19. Equivalent SDOF system (ESDOF)

Finally, the target displacement of the MDOF system is obtained from the maximum displacement of the ESDOF system by rearranging (5.48):

$$(5.53) \quad \delta_t = \Gamma \cdot \Delta_{max}$$

• *FEMA356 and FEMA440- Displacement Coefficient Method (DCM)*

The natural period T_0 of the ESDOF system, corresponding to its elastic branch, should be calculated as:

$$(5.54) T_0 = 2\pi\sqrt{m^* / k_0} ,$$

while FEMA356 gives:

$$(5.55) T_0 = T_i\sqrt{k_i / k_0} .$$

T_i is the fundamental period of the linear MDOF system. The effective mass m^* is not explicitly calculated.

Taking into account (5.54) and (5.55), it follows that:

$$(5.56) T_i = 2\pi\sqrt{m^* / k_i} .$$

Expression (5.56) is correct only if $\{\phi\}$ is the fundamental mode shape. In this case:

$$(5.57) k_i = \frac{V_{b1}}{\delta_1} = \frac{\{1\}^T [m] \{\phi\}_1 \Gamma_1 S_a(T_i)}{\phi_{CN,1} \Gamma_1 S_d(T_i)} = m^* \left(\frac{2\pi}{T_i} \right)^2 ,$$

where V_{b1} and δ_1 are the maximum base shear and control node displacement, corresponding to the fundamental mode of free vibrations of the elastic structure. S_a and S_d stand for pseudo-acceleration and displacement response spectrum respectively.

Strictly speaking, the modal analysis should be performed with reduced stiffness matrix due to the action of the gravity loads through the deform configuration of the structure. In this way the correspondence between T_i and the initial slope of the push-over curve k_i is kept (k_i includes the P- Δ effects).

The strength ratio of the ESDOF system

$$(5.58) R = \frac{m^* S_a(T_0) g}{V_y / \Gamma}$$

is given by FEMA356 as:

$$(5.59) R = \frac{C_m M . S_a(T_0) g}{V_y} ,$$

where M is the total mass of the MDOF system. Consequently, the coefficient C_m should be equal to:

$$(5.60) C_m = \frac{m^* \Gamma}{M} = \frac{\Gamma^2 \{\phi\}^T [m] \{\phi\}}{\{1\}^T [m] \{1\}} ,$$

FEMA356 gives approximate values of C_m , depending on the number of storeys and the structural type. Alternatively, C_m can be taken as the fundamental modal mass coefficient, i.e. applying (5.60) with $\{\phi\}$ equal to the fundamental mode shape vector.

The factor Γ in (5.53), denoted as C_0 in FEMA356, can be evaluated as the fundamental mode participation factor using (5.41) with $\{\phi\}$ equal to the fundamental mode shape vector or can be given approximate values depending on the number of storeys, building type and load vector type.

- *ATC-40 and FEMA440- Capacity Spectrum Method (CSM)*

The natural period T_0 of the ESDOF system, corresponding to its elastic branch, is equal to the fundamental natural period T_1 of the elastic MDOF system. This is a result of (5.55), considering that k_i is equal to k_0 according to the procedure for bi-linear idealization of the push-over curve, adopted in ATC-40 (see Figure 5.6.a). As in the case of DCM, the correspondence between T_i and k_i should be kept.

- *Italian seismic code and EC8*

The procedure in the Italian seismic code and EC8 follows strictly the exposed derivation of the ESDOF system.

- *Comparisons and comments*

The non-linear static procedures in FEMA356, FEMA440 and ATC-40 are consistent with the derivation of the ESDOF system only when the load vector corresponds to the first mode of free vibrations. That conclusion is made neglecting the dependence of C_0 on the load vector type in FEMA356.

In contrast, the procedure adopted in the Italian seismic code and EC8 is fully consistent with the derivation of the ESDOF system.

6. ACCEPTANCE CRITERIA

A given rehabilitation goal (see 2.2) is assumed to be achieved if specified acceptance criteria (safety verifications) are met. The acceptance criteria define the demands on the structural components, imposed by gravity loads and earthquake excitation, and their limiting values. The demands reflect the seismic hazard level, while the limiting values are related to the target building performance level or limit state.

Components are defined as primary and secondary. Component actions are categorized as deformation-controlled and force-controlled. Different approaches for their acceptance (verification) are applied, since they have different influence on the building safety.

6.1 Primary and secondary components

A structure as a whole can survive high level of seismic excitation even if some of its components suffer significant strength and stiffness degradation. Consequently, the acceptance criteria at local (component) level could be more liberal for some elements and more restrictive for other if the seismic demands are well predicted.

These considerations are implemented in the codes by classifying the components as primary and secondary. The lateral resistance degradation of primary components is limited, while the secondary components should be able to support the vertical loads under the strongest design excitation. The designer is free to classify the components as primary or secondary, providing some additional restrictions are met. These restrictions are aimed to reduce the uncertainties in the calculation of the seismic demands. Effects as horizontal torsion, soft storey mechanisms and dynamic instability are almost unpredictable at high levels of system resistance degradation.

- *FEMA356*

FEMA356 restricts the total initial stiffness of secondary components to 25% of that of primary components when the assessment is performed through linear analysis procedure. The secondary components should not be included in the final model. In this way the displacement demands on the secondary components increase.

In the case of NSP, the base shear at the target displacement should not be less than 80% of the maximum base shear developed, i.e. the total resistance degradation is limited to 20% (see 5.3). All the components (primary and secondary) should be included in the model (see 5.1).

Independently on the analysis type, removal of secondary components should not change the regularity classification of the structure.

- *Italian seismic code and EC8*

EC8 restricts the total initial stiffness of secondary components to 15% of that of primary components, while the Italian seismic code does not give quantitative limit.

Similarly to FEMA356, removal of secondary elements should not change the system from irregular to regular.

6.2 Deformation-controlled and force-controlled actions

The actions experienced by the structural components are defined as deformation-controlled (also referred as ductile mechanisms) or force-controlled (brittle mechanisms). The deformation-controlled actions lead to ductile component behaviour, while the force-controlled actions cause brittle component response.

• FEMA356

According to the general definition in FEMA356, displacement-controlled actions lead to component behaviour of type 1 or 2 and ductility capacity more than 2 in case they govern the response (see Figure 6.1). Force-controlled actions are associated with behaviour type 3 or types 1 and 2 if the ductility capacity does not exceed 2.

In case a secondary component exhibits behaviour type 1 with ductility capacity less than 2, the governing action can be still classified as displacement-controlled.

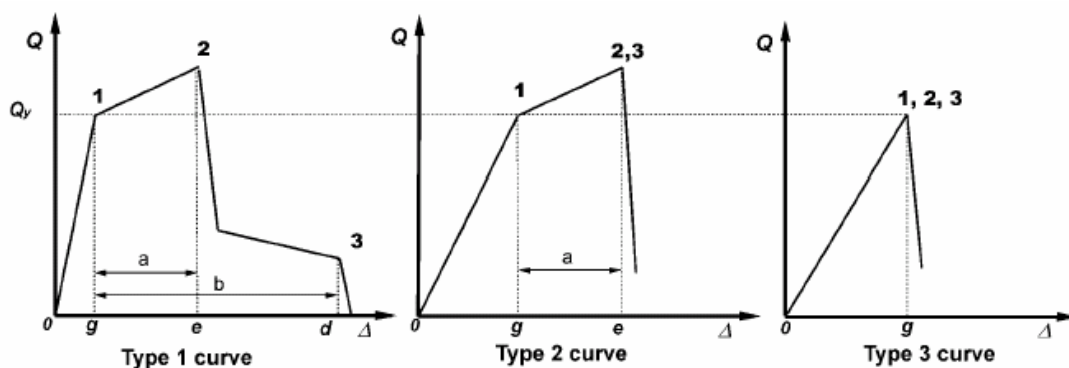

Figure 6.1. Component force versus deformation curves

In the case of reinforced concrete beam-column moment frames, flexure in beams and columns is the only deformation-controlled action for primary components. For secondary elements, shear and inadequate development could be also considered displacement-controlled actions.

• Italian seismic code and EC8

The ductile mechanisms for RC frame structures are flexure in beams and columns. Brittle mechanisms are shear in beams, columns and joints.

• Comparisons and comments

The Italian seismic code and EC8 do not give general quantitative definition for ductile and brittle mechanisms. FEMA356 definition is different for primary and secondary components.

6.3 Deformation limits and force capacities values

- *FEMA356*

Mean values (expected values) of force capacities and deformation limits, multiplied by knowledge factor (see 3), are used for verification of the ductile mechanisms.

Mean minus one standard deviation values (lower-bound values) of force capacities, multiplied by knowledge factor (see 3), are used for verification of the brittle mechanisms.

Mean values (expected values) of ductile mechanism capacities are used, when limit-state analysis is applied.

- *Italian seismic code*

Mean values of deformation limits, divided by confidence factor (see 3), are used for verification of the ductile mechanisms.

Mean values of force capacities, divided by safety factor and confidence factor (see 3), are used for verification of the brittle mechanisms.

Mean values of ductile mechanism capacities, multiplied by confidence factor (see 3), are used when limit-state analysis is applied.

- *EC8*

Mean values of material properties are used for verification of the ductile mechanisms.

Mean values of material properties, divided by partial safety factors (see 3), are used for verification of the brittle mechanisms.

Mean values of material properties are used for evaluation of ductile mechanisms capacities when limit-state analysis is applied.

- *Comparisons and comments*

The approaches in the three codes are more conservative with respect to brittle failure modes than they are with respect to ductile failure modes. For lower knowledge level they are more conservative as well.

6.4 Displacement-based analysis procedures

6.4.1 Linear analysis procedures

- *FEMA356*

Deformation-controlled actions should satisfy the following condition:

$$(6.1) \frac{Q_{UD}}{Q_C} \leq m$$

Where:

- Q_{UD} - deformation-controlled action (flexure in columns and beams) due to gravity loads and earthquake excitation, corresponding to the seismic hazard level under consideration (see 4.1.1.1 and 4.1.1.2);
- Q_C - force capacity;
- m - demand modifier, according to the element properties, element importance (primary or secondary) and target building performance level.

The left hand side of expression (6.1) has a meaning of displacement ductility demand, compared to limiting ductility value m , assuming that the linear procedures give the expected maximum deformations.

The maximum compression strain of confined concrete, needed for flexural strength calculations, should not exceed the buckling strain of the longitudinal reinforcement. Otherwise, low-cycle fatigue of the reinforcing steel may occur.

Force-controlled actions should be verified as:

$$(6.2) Q_C \geq Q_{UF}$$

Where:

- Q_{UF} - force-controlled action (shear in beams, columns and joints) due to gravity loads and earthquake excitation, corresponding to the highest seismic hazard level considered;
- Q_C - force capacity.

If some of the deformation-controlled actions, delivering the force-controlled action under consideration, exceed its elastic limit ($DCRs > 1$ - see 4.3), Q_{UF} should be evaluated by limit-state analysis. Otherwise, Q_{UF} should be obtained for linear structural response:

$$(6.3) Q_{UF} = Q_G + \frac{Q_E}{C_1 C_2 C_3}$$

Where:

- Q_G - force-controlled action due to gravity load;
- Q_E - force-controlled action due to earthquake excitation, obtained through LSP or LDP (see 4.1.1.1 and 4.1.1.2).

Q_E is divided to the C_i coefficients, since the response is linear.

The expression for shear capacity of beams and columns accounts for degradation of the shear-transfer mechanisms after flexural yielding (see 5.1).

• *Italian seismic code*

The ductile mechanisms are verified by comparing chord rotations from the linear analysis to limiting values, corresponding to the limit state under consideration.

The chord rotation is the angle between the tangent to the axis at the yielding end and the chord connecting that end with the end of the shear span ($L_v=M/V$ =moment/shear), i.e. the point of contraflexure. Figure 6.2 shows some common cases of application of this definition. It can be seen that in general the end of the shear span and the point of contraflexure do not coincide. In some cases the shear span is larger than the length of the element, which makes the calculation of the chord rotation impossible.

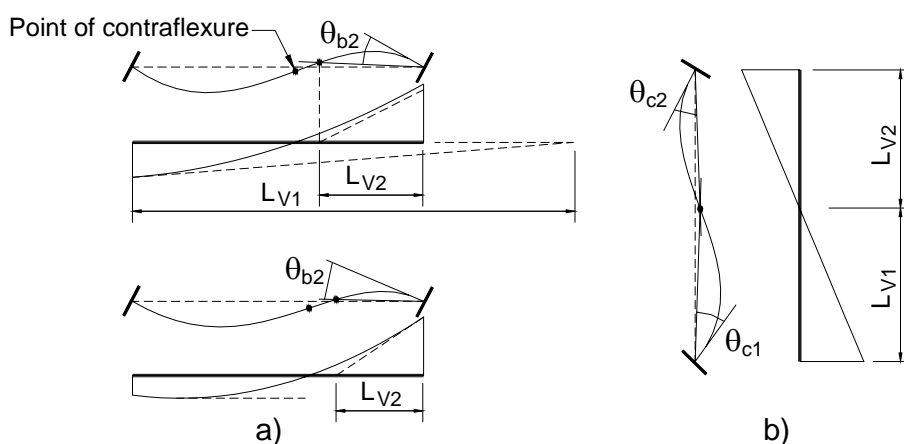

Figure 6.2. Definition of chord rotation: a) beams; b) columns

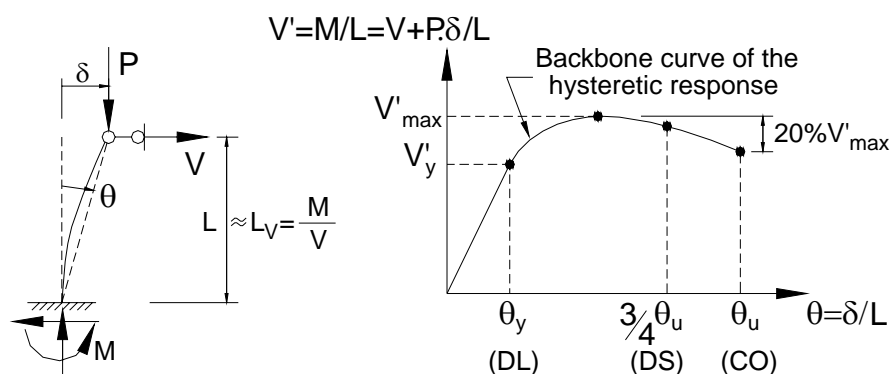

Figure 6.3. Limiting chord rotations

The chord rotation limits are defined and obtained for cantilever or fixed-fixed element, subjected to cyclic imposed displacements without distributed load (see Figure 6.3). The chord rotation at yielding θ_y is evaluated as:

$$(6.4) \theta_y = \phi_y \frac{L_v}{3} + 0.0013 \left(1 + 1.5 \frac{h}{L_v} \right) + \phi_y \frac{d_b f_y}{8 \sqrt{f_c}},$$

where ϕ_y is the curvature at yielding of the end section, L_v - shear span, h - section height, d_b - diameter of the longitudinal reinforcement, f_y - steel yield strength and f_c - concrete compression strength. The first and the third terms are based on mechanical principles. The former represents the flexural deformations, while the later- the steel yield penetration beyond the support section. The second term is obtained experimentally and reflects mainly the shear deformations.

The ultimate chord rotation θ_u can also be evaluated by mechanical model:

$$(6.5) \theta_u = \frac{1}{\gamma_{el}} \left[\theta_y + (\phi_u - \phi_y) L_{pl} \left(1 - \frac{0.5 L_{pl}}{L_v} \right) \right],$$

where $\gamma_{el}=1.5$ for primary elements and 1 for secondary elements, ϕ_u is the ultimate curvature of the end section and L_{pl} - plastic hinge length. The plastic hinge length is obtained by fitting the experimentally found ultimate chord rotations and differs from the length of inelastic action. They both however depend on the same parameters (see 5.1):

$$(6.6) L_{pl} = 0.1 L_v + 0.17 h + 0.24 \frac{d_b f_y}{\sqrt{f_c}}.$$

The Italian seismic code gives also purely empirical expression for the ultimate chord rotation.

The exposed verification procedure for ductile mechanisms is interpreted in the following paragraphs. Some hints for its practical application are given as well.

First discussed is the verification of beams. It can be assumed that beam end sections do not move under gravity load. The seismic action can be represented by cyclic joint rotations (say $\varphi_1=\varphi_2$) with increasing magnitude. For the sake of simplicity, first considered here is the case of monotonically applied rotations up to component failure, indicated by 20% drop of moment resistance at one of the two end regions (see Figure 6.4). First yielding occurs at the end section where the support rotations cause tension of the top reinforcement (the right end section). Plastic mechanism forms when yielding of the bottom reinforcement develops near the left end of the beam. The history of deformations shows, that the plastic rotation demands are higher in the hinge that forms first. At the same time, this zone possesses lower rotation capacity (see 5.1). Therefore, it dictates the beam failure which usually develops as disintegration of the concrete at the bottom of the section.

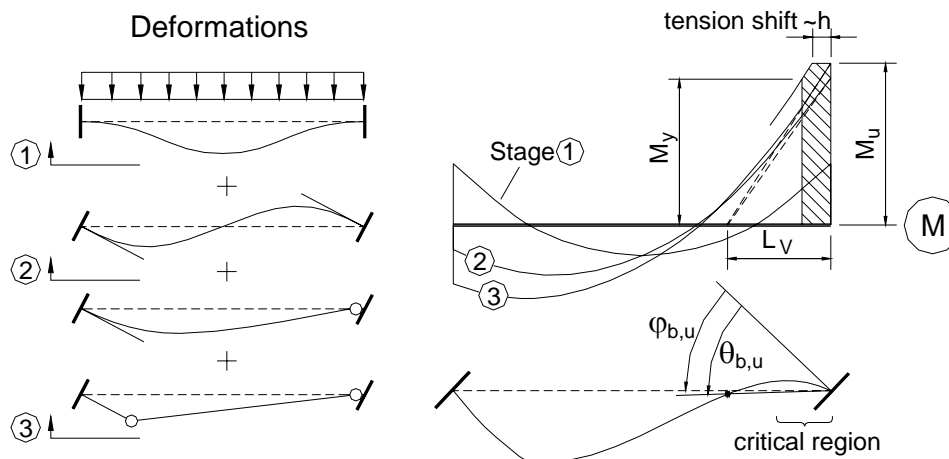

Figure 6.4. Beam under monotonic loading

The ultimate beam deformation can be represented by the chord rotation at the critical end. The shear span L_V varies significantly before the yielding at that location and remains essentially constant afterwards (see Figure 6.4). The variation has influence on the cracking pattern of the region. Neglecting this effect, the chord rotation at yielding can be calculated for simultaneously increasing gravity loads and imposed end rotations. This allows further simplification: $\theta_{b,y}$ can be obtained as yield chord rotation of a cantilever with length L_V (or equivalently fixed-fixed element with length $2L_V$), because the distribution of the internal forces in the beam shear span and in the cantilever is very similar. The same cantilever is also able to predict the plastic chord rotation $\theta_{b,pl}$ with sufficient accuracy. The reason is that the beam and the cantilever have plastic regions with identical properties (cross section, reinforcement and length). Consequently:

$$(6.7) \theta_{b,u} = \theta_{b,y} + \theta_{b,pl} \approx \theta_y(L_V) + \theta_{pl}(L_V).$$

If the monotonic loading up to beam failure is preceded by several smaller cycles of applied end rotations (similar to earthquake situation), $\theta_{b,u}$ decreases due to damage accumulation in the compression zone of the critical region. This effect is well captured in the cyclic tests of cantilevers (see Figure 6.5) and the application of the results to beams is relevant.

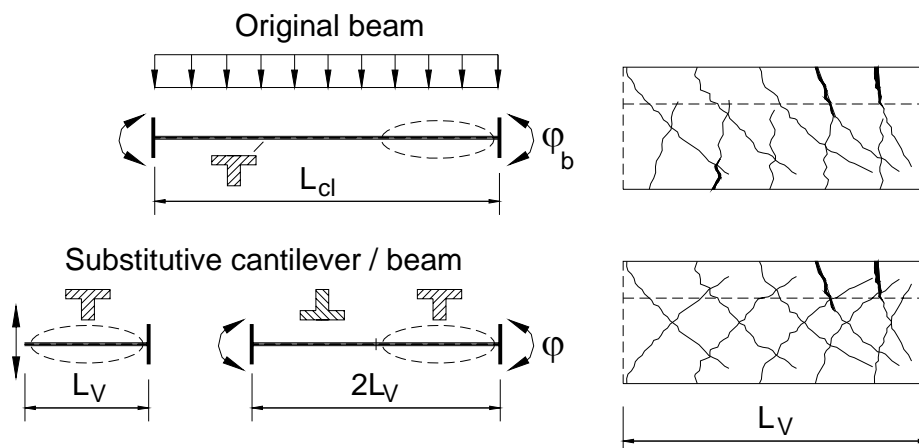

Figure 6.5. Beam under cyclic loading

According to the code verification procedure, the shear span and the chord rotation demand at the critical beam end are well predicted by the linear analysis procedures. The chord rotation capacity is calculated using cantilever. Verification should not be performed for the opposite end of the beam, since it does not govern the failure of the element. Therefore, the confusing case of very large shear span is not of interest.

The demand calculation can be simplified if it is assumed that the end of the shear span lies on the line connecting the two ends of the element in its deformed state (see Figure 6.6.b). The assumption is reasonable, since the use of linear procedures for prediction of deformations of non-linear systems is anyhow subjective. Considering also that the vertical displacements of the beam ends are usually very small, the chord rotations are approximately equal to the joint rotations, obtained directly from the analysis.

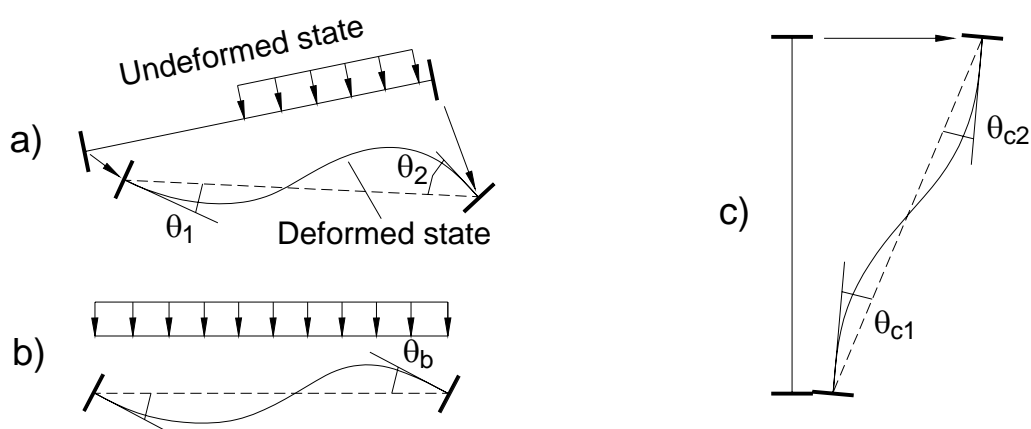

Figure 6.6. Simplified calculation of the chord rotations: a) general; b) beams; c) columns

Generally, the shear span of columns does not vary significantly during the response and their deformation capacity can be well assessed through cantilever. The simplified procedure for calculation of the chord rotation demands can be applied also here (see Figure 6.6.c).

The force-controlled actions should not exceed the corresponding force capacities. The procedure for evaluating the force demands is the same as the FEMA356 procedure. The only difference is that C_i coefficients should not be included in (6.3), since the Italian seismic code adopts the equal displacements principle (see 4.1.1.1 and 4.1.1.2).

The shear resistance is evaluated as in the case of new buildings under non-seismic conditions.

The joints shear strength should be verified only if the joint is not confined. The principal compression and tension stresses in the joint core are checked against the corresponding capacities:

$$(6.8) \sigma_{nc} \leq 0.5f_c$$

$$(6.9) \sigma_{nt} \leq 0.3\sqrt{f_c}$$

The stress limits are lower than the concrete compression and tension uniaxial strengths, since the concrete core is under plane stress state (see Figure 6.7).

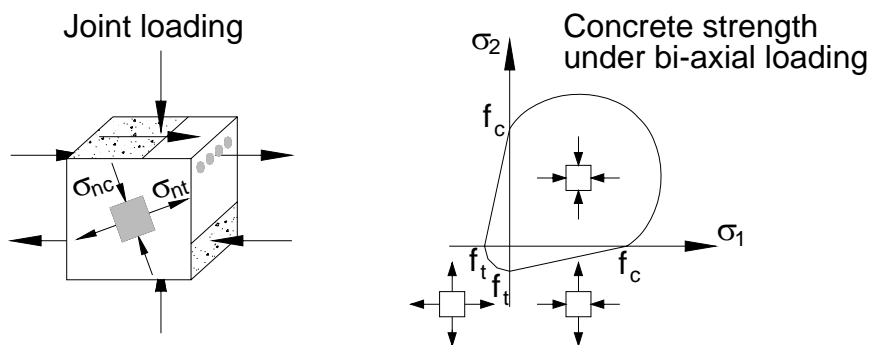

Figure 6.7. Joints strength verification

- EC8

Some of the differences between the Italian seismic code and EC8 are summarized below.

The verification of the ductile mechanisms for damage limitation limit state can be carried out also by comparing the bending moments from the linear analysis with the yield bending moments, accounting for co-existing axial force.

EC8 gives several expressions for the plastic hinge length L_{pl} . As mentioned above, L_{pl} is obtained by fitting experimental data with formula (6.5). It is recognized that the results depend on the way the ultimate curvature ϕ_u is calculated and in particular- on the chosen model for confined concrete. The given options are the EC2 model and Mander model (original or improved).

An empirical expression for the plastic chord rotation is given as an alternative to the second term of (6.5):

$$(6.10) \theta_u^{pl} = \frac{1}{\gamma_{el}} 0.0129(0.2^{\nu}) \left[\frac{\max(0.01, \omega')}{\max(0.01, \omega)} f_c \right]^{0.225} \left(\frac{L_V}{h} \right)^{0.375} 25^{\left(\alpha \rho_{sx} \frac{f_{yw}}{f_c} \right)},$$

where $\gamma_{el}=1.5$ for primary elements and 1 for secondary elements, $\nu=N/b.h.f_c$ (N, axial force, b - width of compression zone, h - section depth, f_c - concrete compression strength), ω and ω' - mechanical volumetric ratios of the compression and tension reinforcement respectively, L_V - shear span. The last term depends on the confinement properties of the section and takes unit value if the stirrups are not anchored in the concrete core. As discussed in 5.1, the shear span L_V is related to the length of the plastic region, while the other parameters determine the capacity of the section to develop plastic deformations. The height of the section h has influence on the two quantities.

The expression for shear capacity of beams and columns accounts for degradation of the shear-transfer mechanisms after flexural yielding by reducing the contribution of concrete

mechanisms and stirrups for increasing ductility demands. The contribution of the axial loads is added by independent term.

- *Comparisons and comments*

Generally, the three codes follow common approach, demanding elastic behaviour for brittle mechanisms and controlled inelastic deformations for ductile failure modes of primary and secondary components. The difference is in the definition of displacement- and force-controlled actions for secondary components. FEMA356 treats shear and development failure in secondary beams and columns as ductile modes, while Italian seismic code and EC8- as brittle. In other words FEMA356 accepts more damage in secondary components than Italian seismic code and EC8 do.

FEMA356 procedure for verification of ductile mechanisms can be analyzed in the context of Italian seismic code and EC8. Figure 6.8 shows the variation of the bending moment in the critical section of a beam versus the chord rotation. Considering the graph, verification inequality (6.1) can be rewritten as:

$$(6.11) \quad \frac{Q_{UD}}{Q_C} = \frac{M_{G+E}}{M_u} \approx \mu_\theta = \frac{\theta}{\theta_y} \leq m.$$

Therefore, the coefficient m represents the limit on the chord rotation ductility.

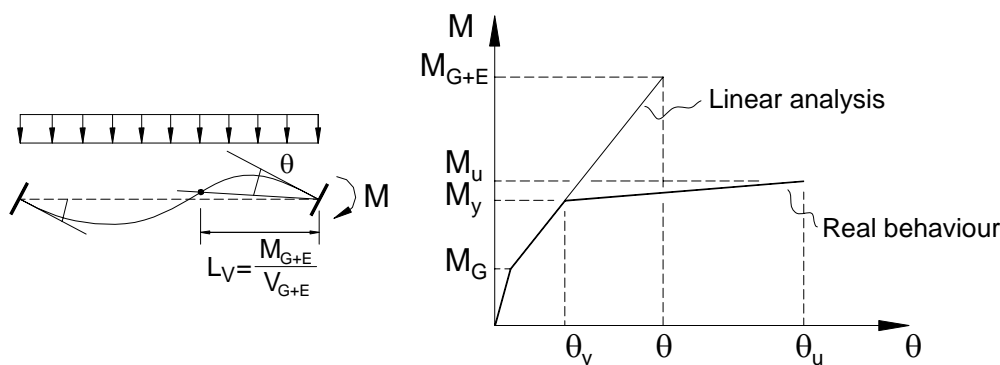

Figure 6.8. Chord rotation variation

The Italian code does not consider the reduction of the shear resistance of beams and columns under inelastic flexural deformations. This results in reduced safety against brittle failure.

6.4.2 Non-linear analysis procedures

- *FEMA356*

The plastic hinge rotations from the non-linear analysis should not exceed given limits, which depend on the component classification (primary or secondary) and on the target building performance level under consideration (see Table 5.1 and Table 5.2). Primary components should not experience strength degradation. Primary joints and columns controlled by shear should not develop any plastic deformations. All the secondary components may suffer lateral strength degradation, providing they maintain their capacity to carry gravity loads.

- *Italian seismic code*

The maximum chord rotations from the non-linear analysis should not exceed the limits θ_y , $\frac{3}{4}\theta_u$ and θ_u for DL, DS and CO limit state respectively (see 6.4.1).

The maximum force demands on the brittle mechanisms should be less than the corresponding capacities. In the case of NSP (see 5.1), the maximum forced-controlled actions are not always associated with the maximum control node displacement (target displacement). When the performance point is on the descending branch of the capacity curve, the Italian code states that the maximum force demands correspond to the point with maximum base shear resistance. This is important when the non-linear model accounts for flexural behaviour only.

- *EC8*

EC8 differs from the Italian code mainly in the calculation of the beam and column shear resistance (see 6.4.1).

- *Comparisons and comments*

The comments and comparisons, made about the safety verifications in case of linear analysis procedures, apply here with some exceptions. In the case of non-linear procedures, FEMA356 allows inelastic deformations associated also with shear and inadequate developments in primary beams (see 5.1) and shear in secondary joints.

6.5 Force-based linear procedures- Italian seismic code and EC8

The force-based linear procedures are used in the Italian seismic code and EC8 for evaluation of Severe Damage (DS) LS and Significant Damage (SD) LS respectively.

The component deformation- and force-controlled actions, obtained from the analysis, should not exceed the corresponding force capacities, evaluated for non-seismic situations.

The approach does not provide information about the level of damage because the deformation demands and capacities are not explicitly calculated.

7. CONCLUSION

Five codes for assessment of existing buildings (Italian seismic code, EC8, FEMA356, ATC-40 and FEMA440) have been analyzed by looking at the theoretical basis of the problems. The code assumptions and simplifications were pointed out together with their possible inconsistencies and weaknesses. Comparisons between the different procedures were performed as well. Some of the important outcomes are summarized below.

- (1) The linear analysis procedures in the Italian seismic code and EC8 are based on the equal-displacement principle, which may result in nonconservative estimation of the deformation demands in the case of short-period structures.
- (2) Neither code takes into account strength distribution in plan as a property of the structure that can trigger torsional response. In other words, the choice of model dimension (2D vs. 3D) is based only on the initial elastic properties of the structure.
- (3) EC8 and the Italian seismic code include in-elevation strength distribution as a criterion for choice between LSP and LDP, although they both do not reflect the strength.
- (4) The Italian seismic code and EC8 do not consider the dynamic P- Δ effect. According to FEMA440, the procedures implemented in FEMA356 and ATC-40 are not able to adequately capture the dynamic instability phenomenon. However, the limit on the drop of lateral resistance of the structure, imposed in FEMA356, has not been considered. It was shown that this restriction can be interpreted as conservative measure against dynamic instability.
- (5) According to FEMA356, the rotation capacity of beam/column plastic hinges is independent of the shear span and section depth even though these two parameters have very important influence on the component behaviour. It was shown that this is particularly true in the case of beams, since the gravity load causes concentration of plastic deformations.
- (6) The non-linear model for shear-controlled behaviour of beams in FEMA356 is not realistic because it allows for shear increase after the shear resistance has been reached.
- (7) The non-linear static procedure in the Italian seismic code and EC8 is based on elastic-perfectly plastic behaviour of the Equivalent SDOF system. Strength and stiffness degradation effects are not considered. This simplification may lead to underestimation of the target displacement.
- (8) The non-linear static procedures in FEMA356, FEMA440 and ATC-40 are consistent with the exposed derivation of the ESDOF system only when the load vector corresponds to the first mode of free vibrations. In contrast, the procedure adopted in the Italian seismic code and EC8 is fully consistent with the derivation.
- (9) The Italian code does not consider the reduction of the shear resistance of beams and columns under inelastic flexural deformations. This results in reduced safety against brittle failure.

(10) The force-based linear procedures, implemented in the Italian seismic code and EC8, are of doubtful relevance for seismic assessment of existing buildings.

REFERENCES

- ACI 318 [1999] “Building Code Requirement for Structural Concrete (ACI 318-02) and Commentary (ACI 318R-02),” American Concrete Institute.
- ATC-40 [1996] “Seismic Evaluation and Retrofit of Concrete Buildings (Volume 1)”.
- Chopra A.K. [2000] “Dynamics of Structures Theory and Application to Earthquake Engineering (Second Edition),” *Prentice Hall*.
- Chopra A. K., Goel R. K. [2001] “A Modal Pushover Analysis Procedure to Estimate Seismic Demands for Buildings: Theory and Preliminary Evaluation,” Pacific Earthquake Engineering Research Center, California, USA.
- Fardis M.N. [2005] Class Notes, European School for Advanced Studies in Reduction of Seismic Risk (ROSE School), University of Pavia, Italy.
- FEMA273 [1997] “NEHRP Guidelines for the Seismic Rehabilitation of Buildings”.
- FEMA274 [1997] “NEHRP Commentary on the Guidelines for the Seismic Rehabilitation of Buildings”.
- FEMA356 [2000] “Prestandard and Commentary for Seismic Rehabilitation of Buildings”.
- FEMA440 “Improvement of Nonlinear Static Seismic Analysis Procedures”.
- FIB Bulletin 24 [2003] “Seismic Assessment and Retrofit of Reinforced Concrete Buildings,” State-of-art Report.
- Kowalski M.J., Priestley M.J.N [2000] “Improved Analytical Model for Shear Strength of Circular Reinforced Concrete Columns in Seismic Regions,” *ACI Structural Journal*.
- Krawinkler H., Seneviratna [1996] G.D.P.K. Pros and cons of a pushover analysis of seismic performance evaluation. *Engineering Structures*, Vol.20, Nos 4-6.
- Lupoi G. [2003] “Limitations and Performances of Different Approaches for Seismic Assessment of Existing buildings”, *Individual Study*, European School for Advanced Studies in Reduction of Seismic Risk (ROSE School), University of Pavia, Italy.
- Mander J.B., Priestley M.J.N. and Park R. [1998] “Theoretical Stress-Strain model for Confined Concrete,” *Journal of the Structural Division*, ACSE, Vol.114, No.8.
- Norme tecniche per il progetto, la valutazione e l’adeguamento sismico degli edifici- **BOZZA** di Testo coordinato dell’Allegato 2 – Edifici – aggiornamento 9/9/04

Penelis G.G., Kappos A.J. [1997] "Earthquake-resistant Concrete Structures," *E & FN SPON*.

prEN 1998-1 [2003] "Eurocode 8: Design of Structures for Earthquake Resistance. Part 1: General Rules, Seismic Actions and Rules for Buildings", Final Draft.

prEN 1998-3 [2003] "Eurocode 8: Design of Structures for Earthquake Resistance. Part 3: Strengthening and Repair of Buildings," pre Stage 49.

Priestley M.J.N. [2003] "Myths and Fallacies in Earthquake Engineering, Revisited," *IUSS Press*.

Priestley M.J.N., Seible F., Calvi G. M. [1996] "Seismic Design and Retrofit of Bridges," *JOHN WILEY & SONS, INC*.

Георгиев Ат. [2003] "Прътови модели за проектиране на стоманобетонни елементи. Част I: Фермови модели за В- области" *Литера*, България.