

# Satellite Communications

Marc VAN DROOGENBROECK

Department of Electrical Engineering and Computer Science  
University of Liège

Academic year 2023-2024

<https://orbi.uliege.be/handle/2268/133976>

## Example of an analog communication system

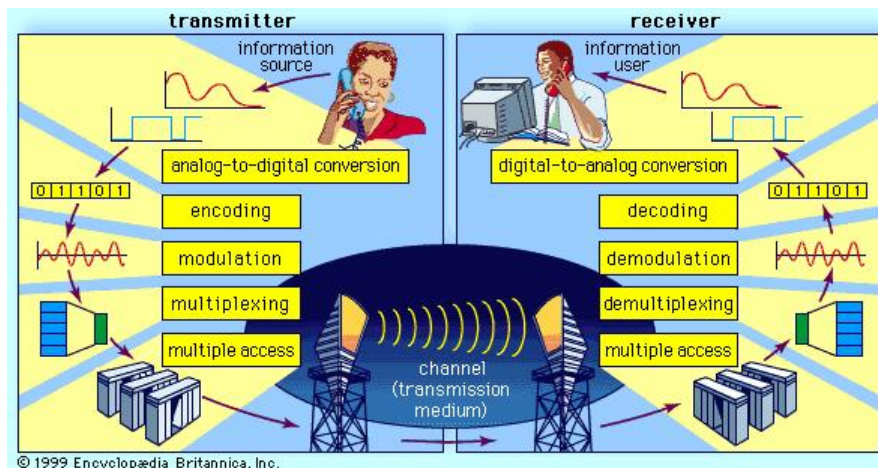

Main components:

- 1 signal
- 2 transmitting channel (cable, radio)
- 3 electronics (amplifiers, filters, modems, etc)

and a lot of engineering!

# Outline

- 1 Signal processing elements
  - Signal  $\equiv$  information!
  - Source coding (dealing with the information content)
  - Modulation
  - Multiplexing
- 2 Propagation and radio communications
  - Introduction to radio communications
  - Radiowave propagation
  - Examples of antennas
- 3 Engineering
  - Noise
  - Link budget



Marc VAN DROOGENBROECK

Signal processing elements  
Propagation and radio communications  
Engineering

Satellite Communications

Signal  $\equiv$  information!  
Source coding (dealing with the information content)  
Modulation  
Multiplexing

# Outline

- 1 Signal processing elements
  - Signal  $\equiv$  information!
  - Source coding (dealing with the information content)
  - Modulation
  - Multiplexing
- 2 Propagation and radio communications
  - Introduction to radio communications
  - Radiowave propagation
  - Examples of antennas
- 3 Engineering
  - Noise
  - Link budget



Marc VAN DROOGENBROECK

Satellite Communications

## Main *types* of satellite → different *types* of information

- ***Astronomical*** satellites: used for the **observation** of distant planets, galaxies, and other outer space objects.
- ***Navigational*** satellites [GPS, Galileo, BeiDou, GLONASS]: they use radio time signals transmitted to enable mobile receivers on the ground to determine their exact location (**positioning**).
- ***Earth observation*** satellites: for environmental **monitoring**, meteorology, map making (**Sentinel constellations**).
- ***Miniaturized*** satellites: satellites of unusually low masses and small sizes. For example, for **educational** purposes (**OUFTI-1/2**).
- ***Communications*** satellites: stationed in space for the purpose of **telecommunications**. Modern communications satellites typically use geosynchronous orbits, or Low Earth orbits (**LEO**).

## Types of data streams

Types of data	Characteristics
<b>Control data</b>	Must be <b>very reliable</b>
<b>Payload</b>	Unicast communication for mobile ground station
▷ Measurements	<b>Accurate</b> signals with constant monitoring
▷ Remote sensing data	<b>High volume</b> of downstream data
▷ Positioning data	Accurate time reference ( <b>synchronization</b> )
▷ Broadcasting	<b>Digital television</b> channels
▷ Digital data	<b>Voice</b> + data ( <b>Internet</b> ) for remote areas

Because the purposes of data sent are different, the mechanisms to transmit the data are designed according to the constraints.

Simplified *typology* of data streams:

- **control data** (this communication channel needs a backup!)
- **payload** (+ some unavoidable **overhead**)

# Positioning systems

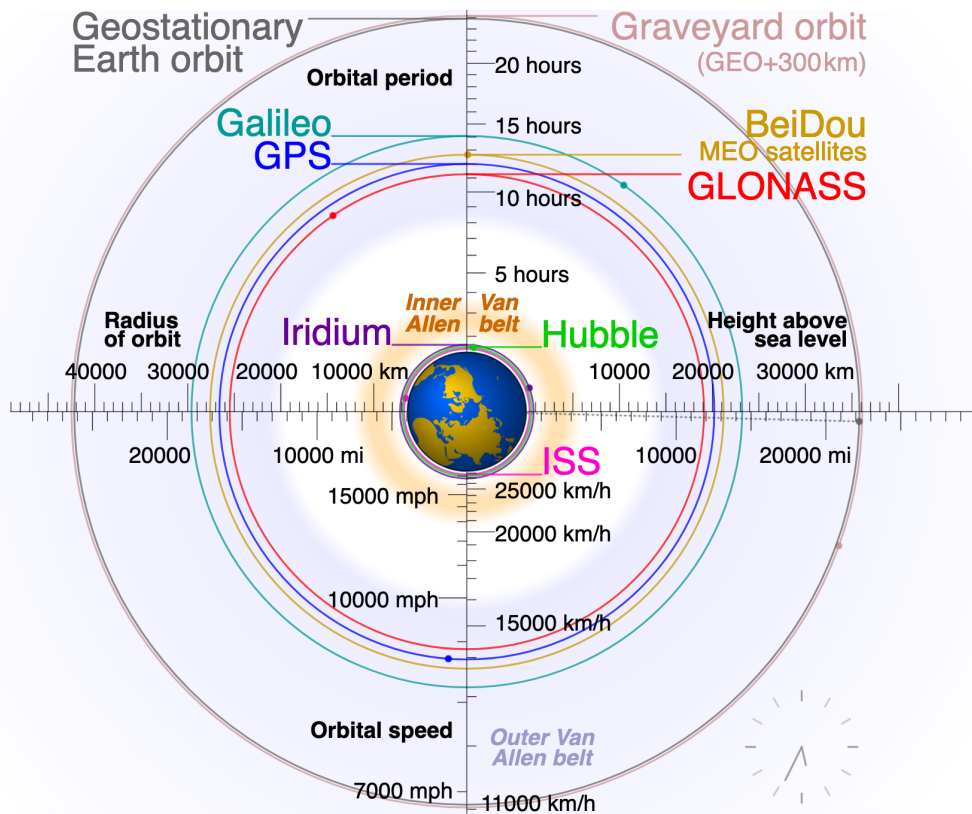

## Example: constellation of GPS satellites

- 6 planes with a  $55^\circ$  angle with the equator, spaced by  $60^\circ$  and with 4 satellites per plane (24 satellites in total)
- Located on high orbits (but **sub-geostationary**)/revolution in 12 hours
- Transmitting **power** of 20 to 50 [W]

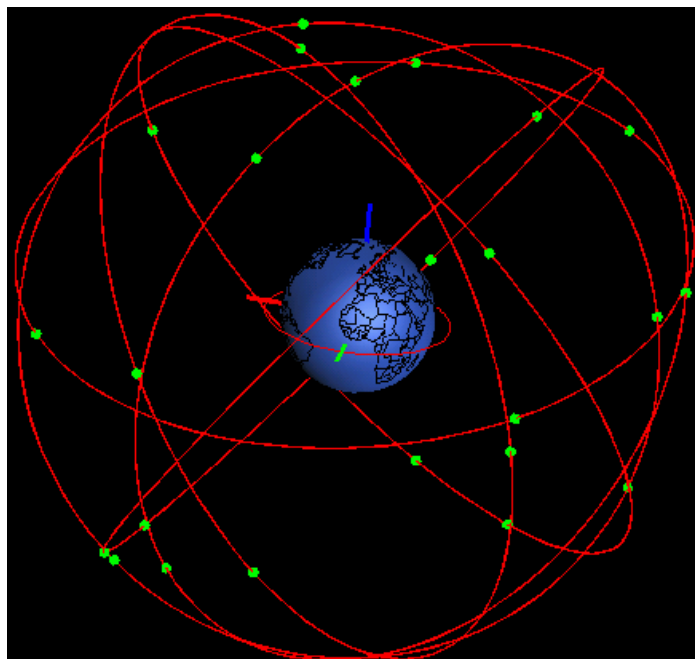

- Orbital altitude: 23,222 [km] (MEO - Medium Earth Orbit)
- 3 orbital planes, 56° inclination, separated by 120° longitude
- Constellation of 30 satellites (with working 24 [3x8] satellites and 6 [3x2] spares)

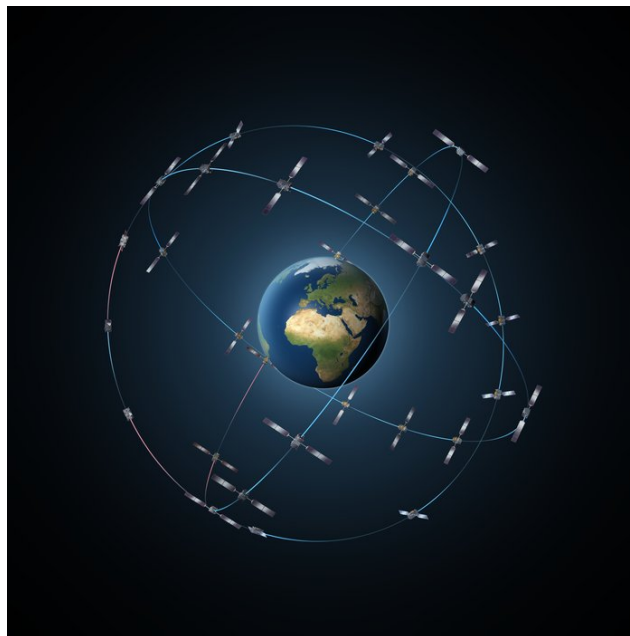

## Deployment of Galileo

- First launches: 2 satellites in October 2011, 2 satellites in October 2012. These were test satellites.
- First Full Operational Capability satellite launched in November 2013.
- August 2014, two more satellites (but ... injected on a wrong orbit).
- October 2022: 23 satellites fully operational, 1 unavailable, and 4 not usable.





## Starlink Initial Phase

1,584 satellites into 72 orbital planes  
of 22 satellites each

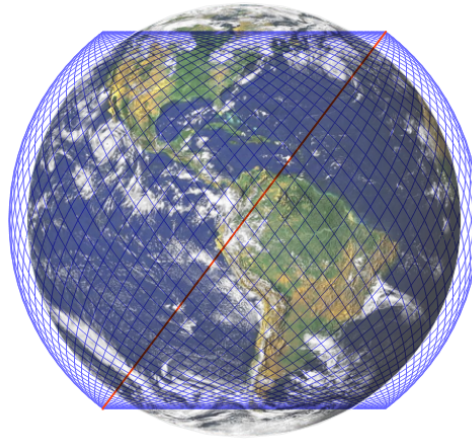

## Main characteristics:

- LEO orbits (550 km for phase 1)
- 4,519 launched and on orbit (July 2023)
- American regulator (FCC) approved 12,000 satellites
- Internet service: 2,000,000 subscribers (September 2023)

## Starlink: controversy

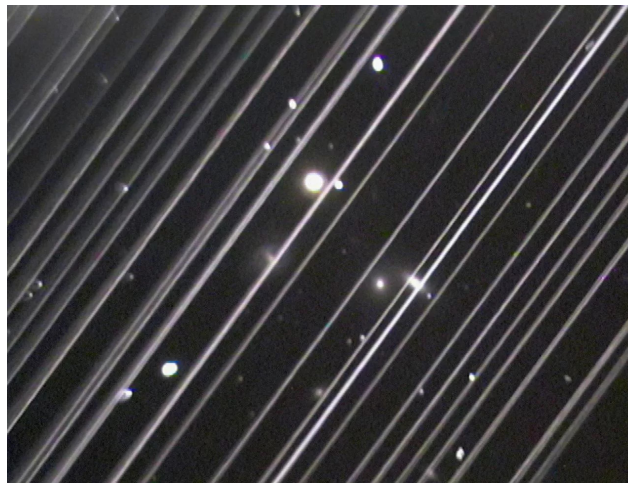

## Main issues:

- light pollution; ground based astronomy is jeopardized (creation of trails in the sky)
- presence of space debris, danger for satellite collision
- technology not fully tested
- usefulness ?! (it's available in Belgium)

# Main issues related to signals

- 1 Signal **source handling** (*preparation of the signal, at the source, in the transmitter*):
  - **filtering** (remove what is useless for communications)
  - **analog**  $\leftrightarrow$  **digital (digitization)**
  - remove the redundancy in the signal: **compression**
- 2 Signal over the **channel**:
  - **signal shaping** to make it suitable for transmission (*coding, modulation, multiplexing, etc*)
  - **signal power** versus the **noise signal** (protect the signal against noise effects)

## Digitization I

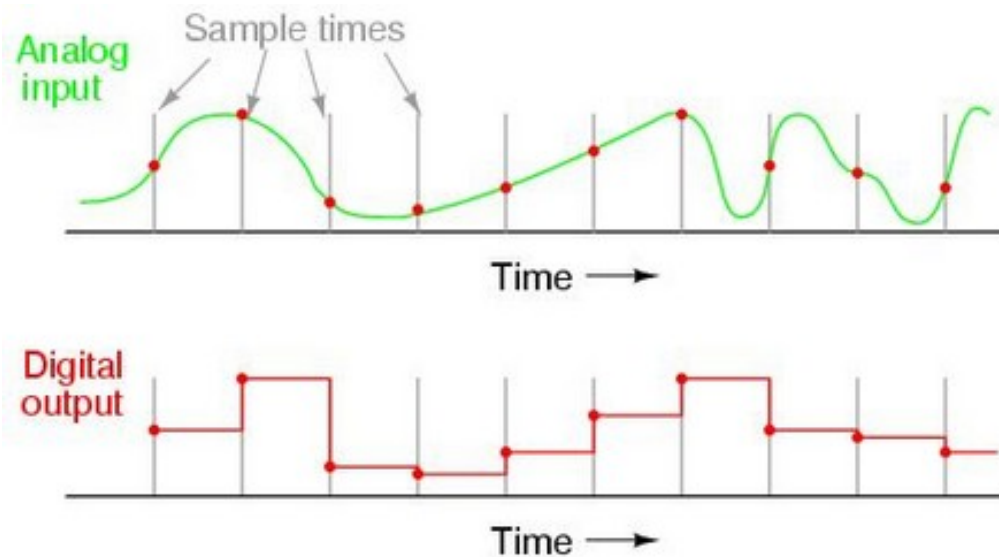

Reasons for going digital:

- 1 possibility to **regenerate** a digital signal
- 2 **better bandwidth usage**

# Digitization II

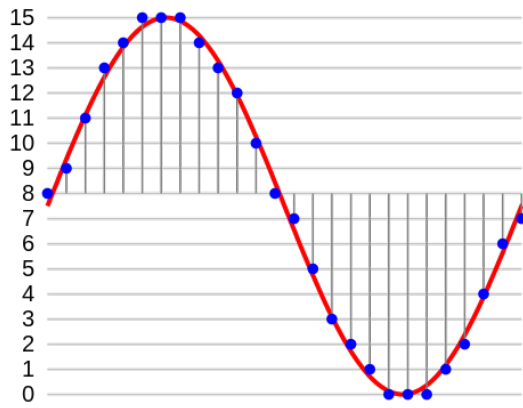

Digitization = from analog to digital

analog	digital
$g(t)$	samples $g[iT]$ , with $i = 0, 1, 2, \dots$ and $T =$ a time period
signal over time	<i>sampling rate</i>
	$\Rightarrow$ series of <i>samples</i>
	each sample is encoded with $n$ bits ( <i>quantization</i> )
	finally, we have a bit stream: 01110...



# Digitization III

## Digitization in numbers:

- 1  $f_s$ : sampling frequency
  - Let  $W$  be the highest frequency of the signal to be converted
  - **theoretical** lower bound:  $f_s > 2W$  [SHANNON'S theorem]
  - **practical rule** (NYQUIST criterion):  $f_s > 2.2W$
- 2  $n$ : number of bits per sample (quantization)
- 3 **bit rate** =  $f_s \times n$

signal	band	$W$	$f_s$	$n$	bit rate
units	Hz	Hz	sample/s	b/sa.	b/s
audio (telephone)	[300 Hz, 3400 Hz]	3400 Hz	8000 sa./s	8	64 kb/s
audio (CD)	[0 Hz, 20 kHz]	20 kHz	44.1 ksa./s	16	705.6 kb/s





# Analog and digital signals: don't confuse *information* and its *representation*!

Analog information signal

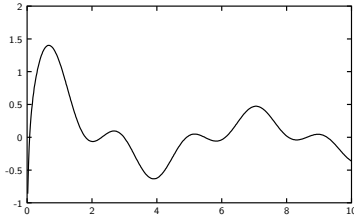

Digital information signal

1 0 1 0 1 1

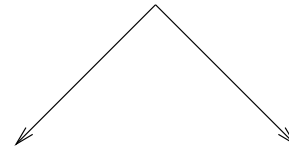

Analog representation

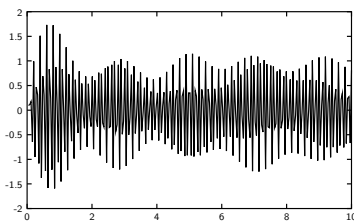

Analog representation

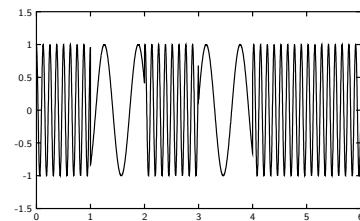
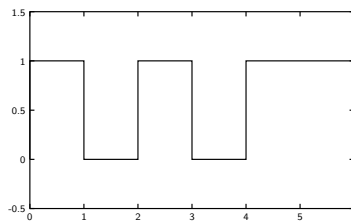

## Characterization of signals over the channel

Analog signal	Digital signal
bandwidth [Hz]	bit rate [bit/s]
Signal to Noise Ratio (S/N or SNR)	Bit Error Rate (BER)
bandwidth of the underlying channel [Hz]	

Reasons for going digital:

- possibility to **regenerate** a digital signal
- **better bandwidth usage**

### Example (better bandwidth usage: from **analog** to **digital** television)

- **analog PAL television channel**: bandwidth of 8 [MHz]
- **digital television**, PAL quality  $\sim 5$  [Mb/s]
  - With a 64-QAM modulation, whose *spectral efficiency* is 6 b/s per Hz. A bandwidth of 8 [MHz] allows for 48 [Mb/s].
  - **Conclusion**: thanks to digitization, there is room for 10 **digital television channels** instead of 1 **analog** television channel.

# Software organization of a transmitter/receiver: the OSI reference model

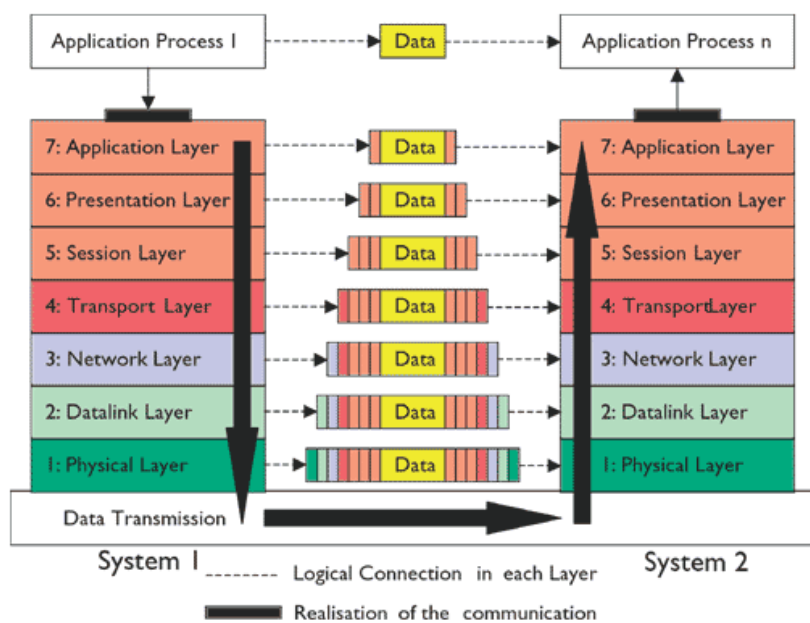

Consequence: encapsulation  $\Rightarrow$  overhead

## OSI reference model vs Internet model (+ some corresponding Internet protocols)

OSI Model	Internet Model	Internet Protocols
Application	Application	HTTP, HTTPS, SSH, DNS, SSL, FTP, POP3, SMTP, IMAP, Telnet, NNTP
Presentation		
Session		
Transport	Transport	TCP, UDP
Network	Network	IP, ICMP, ARP, DHCP
Datalink	Network Link	Ethernet, PPP, ADSL
Physical		

# Elements of a communication system I

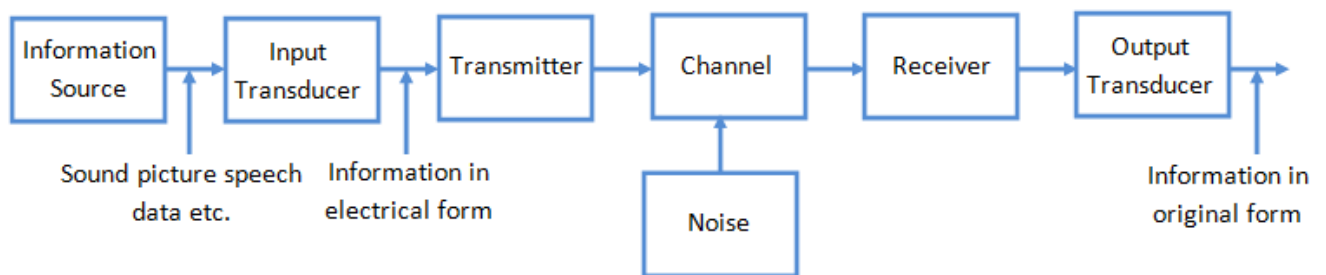

Figure: Block diagram of a communication channel for a **single signal/user** (no sharing of the channel).

# Elements of a communication system II

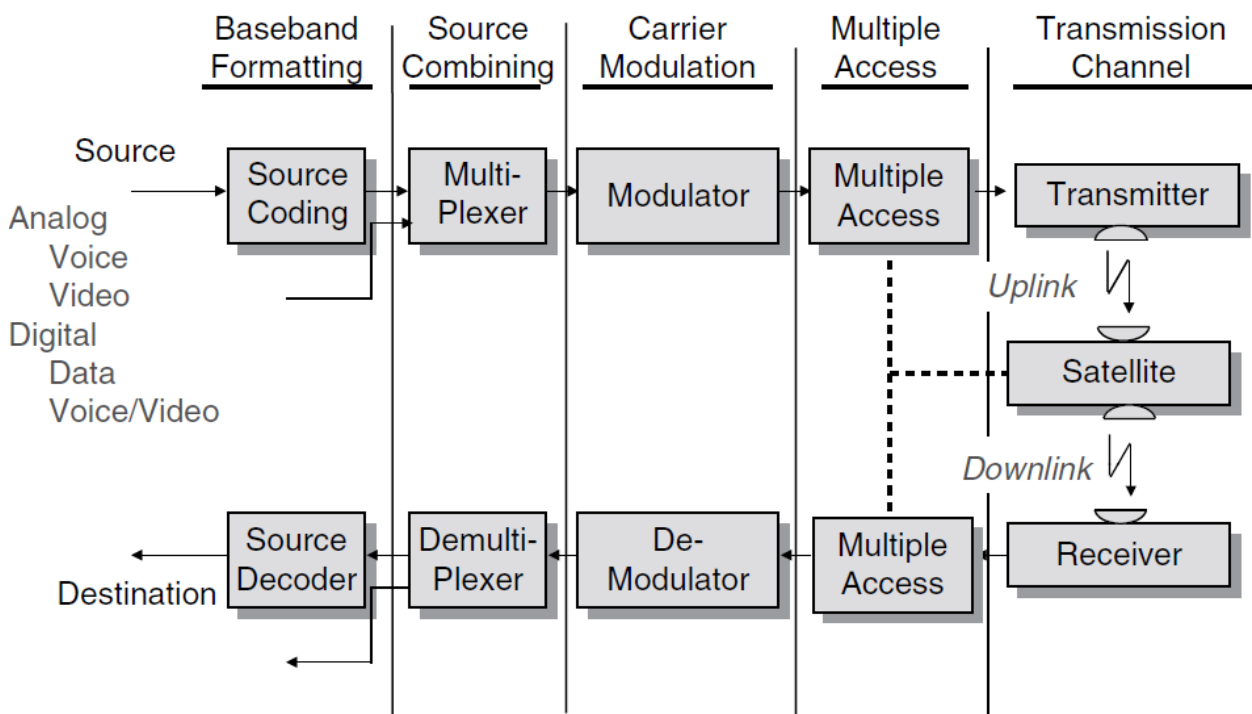

Figure: Block diagram of a communication channel for **multiple users** (multiplexing, modulation and multiple access are added).

# Outline

- 1 Signal processing elements
  - Signal  $\equiv$  information!
  - Source coding (dealing with the information content)
  - Modulation
  - Multiplexing
- 2 Propagation and radio communications
  - Introduction to radio communications
  - Radiowave propagation
  - Examples of antennas
- 3 Engineering
  - Noise
  - Link budget



Information theory and channel capacity: there is a *maximum* bit rate (the sky is not the limit...)! I

## Theorem (SHANNON-HARTLEY)

The channel *capacity*  $C$  (condition for the Bit Error Rate  $BER \rightarrow 0$ ) is expressed in *bits (of information) per second* and given by

$$C [b/s] = W \log_2 \left( 1 + \frac{S}{N} \right) \quad (1)$$

where

- $W$  is the channel bandwidth in Hz
- $\frac{S}{N}$  the Signal to Noise ratio (in watts/watts, not in dB).



# Consequences of the capacity theorem

Let  $R_b$  be the bit rate [b/s] and  $E_b$  the energy per bit [Joule/b], we have  $S = E_b R_b$  [W], and  $N = N_0 W$  (where  $N_0$  is the noise spectral power density;  $N_0 = k_B T$  as discussed later). Therefore:

$$C = W \log_2 \left( 1 + \frac{E_b R_b}{N_0 W} \right) = W \log_2 \left( 1 + \frac{E_b}{N_0} \eta \right) \quad (2)$$

The ratio  $\frac{R_b}{W}$  is defined as the *spectral efficiency*  $\eta$  given in [b/s] per [Hz].

Consequences: 3 degrees of freedom (but not more)

- 1 the  $\frac{E_b}{N_0}$  ratio. We only have control over  $E_b$  (it is our own design);  $N_0$  is not controllable.
- 2 the *spectral efficiency*  $\eta = \frac{R_b}{W}$  (which depends on the technology  $\rightarrow$  this is also our choice).
- 3 for a fixed  $\frac{E_b}{N_0}$  ratio and spectral efficiency,  $C$  can only be increased by increasing the bandwidth. But the **bandwidth  $W$  is a scarce resource**.



## Forward Error Coding

A simplistic example of **Forward Error Coding (FEC)** consists to transmit each data bit 3 times, known as a (3,1) repetition code.

Received bits	Interpreted as
000	0 (error free)
001	0
010	0
100	0
111	1 (error free)
110	1
101	1
011	1



# Other forward error codes

- Hamming code
- Reed–Solomon code
- Turbo code, ...

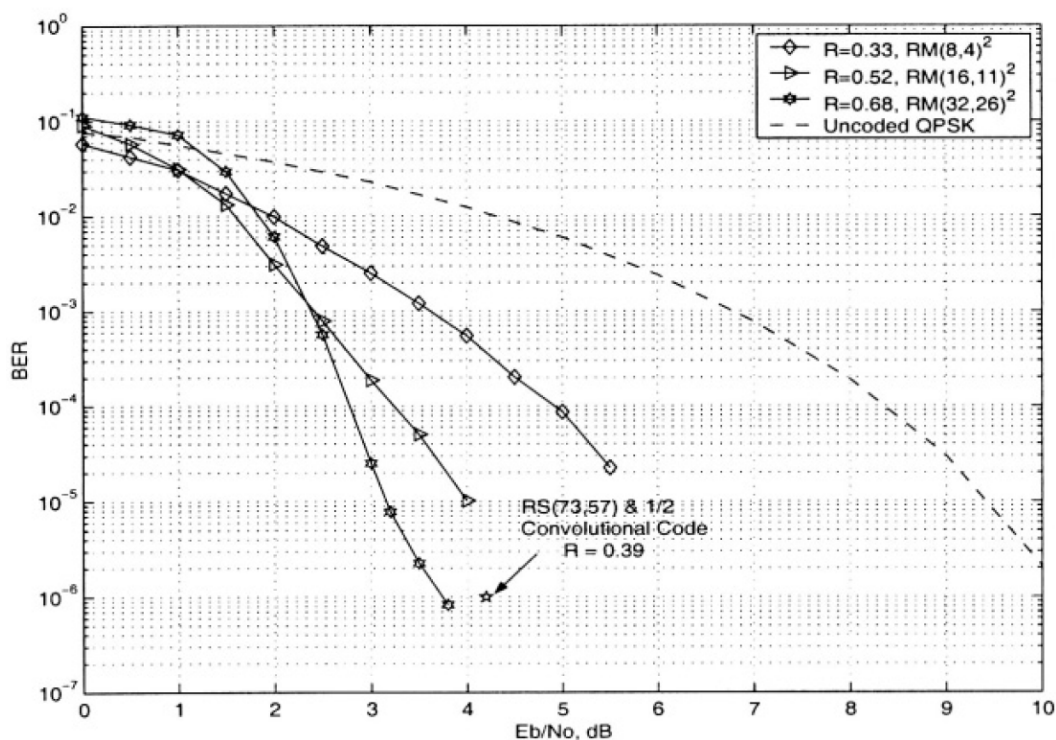

Signal processing elements  
Propagation and radio communications  
Engineering

Signal ≡ information!  
Source coding (dealing with the information content)  
Modulation  
Multiplexing

## Outline

- 1 Signal processing elements
  - Signal ≡ information!
  - Source coding (dealing with the information content)
  - Modulation
  - Multiplexing
- 2 Propagation and radio communications
  - Introduction to radio communications
  - Radiowave propagation
  - Examples of antennas
- 3 Engineering
  - Noise
  - Link budget



# Modulation: principles

## Principle

Modulation is all about using of a **carrier** cosine at frequency  $f_c$  for transmitting information. The **carrier** is  $A_c \cos(2\pi f_c t)$

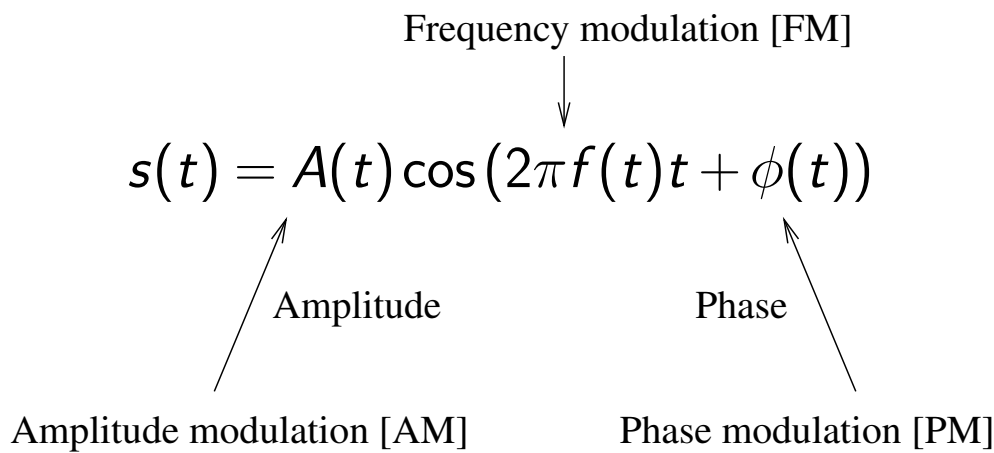

# Consequences of modulation

- frequency band is shifted towards the carrier frequency ( $\Rightarrow f_c$ )
- bandwidth modification, compared to that of the modulating signal  $m(t)$

Effects of **Amplitude Modulation** on the spectrum (  $s(t) = A_c m(t) \cos(2\pi f_c t)$  )

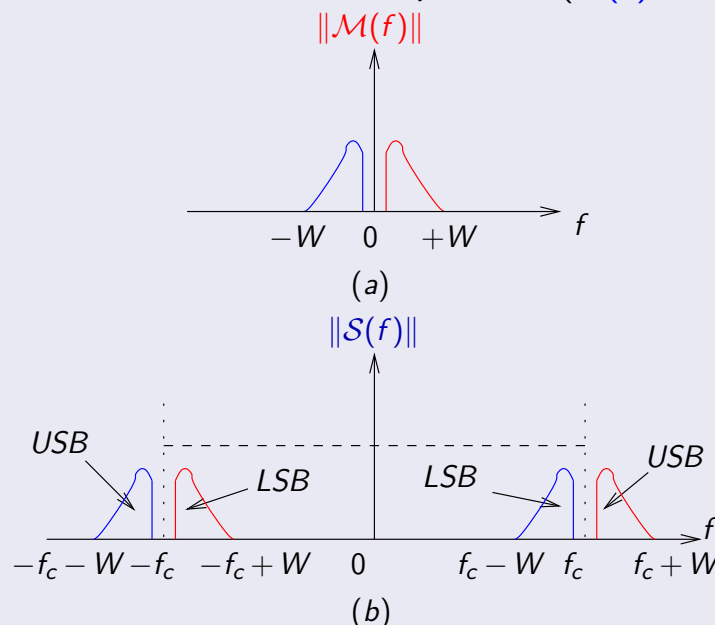

# Demodulation of an AM modulated signal: principles

Received signal:  $s(t) = m(t) \cos(2\pi f_c t)$ . Task: recover  $m(t)$ .

Principles of a synchronous demodulation. At the receiver:

- 1 acquire a **local, synchronous, copy of the carrier**  $f_c \Rightarrow$  build a local copy of  $\cos(2\pi f_c t)$
- 2 **multiply**  $s(t)$  by  $\cos(2\pi f_c t)$ :  
[ $\cos a \cos b = \frac{1}{2} \cos(a - b) + \frac{1}{2} \cos(a + b)$ ]

$$s(t) \cos(2\pi f_c t) = m(t) \cos^2(2\pi f_c t) \quad (3)$$

$$= m(t) \left[ \frac{1}{2} + \frac{1}{2} \cos(2\pi(2f_c)t) \right] \quad (4)$$

$$= \frac{1}{2} m(t) + \frac{1}{2} m(t) \cos(2\pi(2f_c)t) \quad (5)$$

- 3 **filter out** the  $2f_c$  components  $\rightarrow \frac{1}{2} m(t)$



## Demodulation of an AM modulated signal: interpretation in the spectral domain

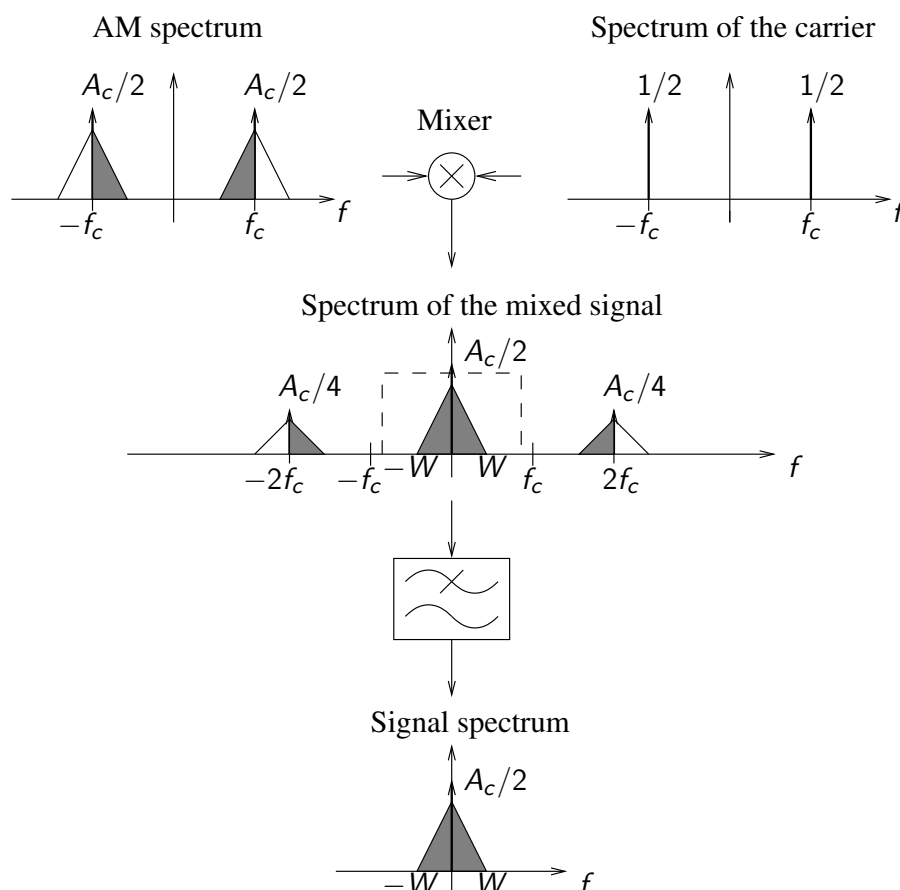

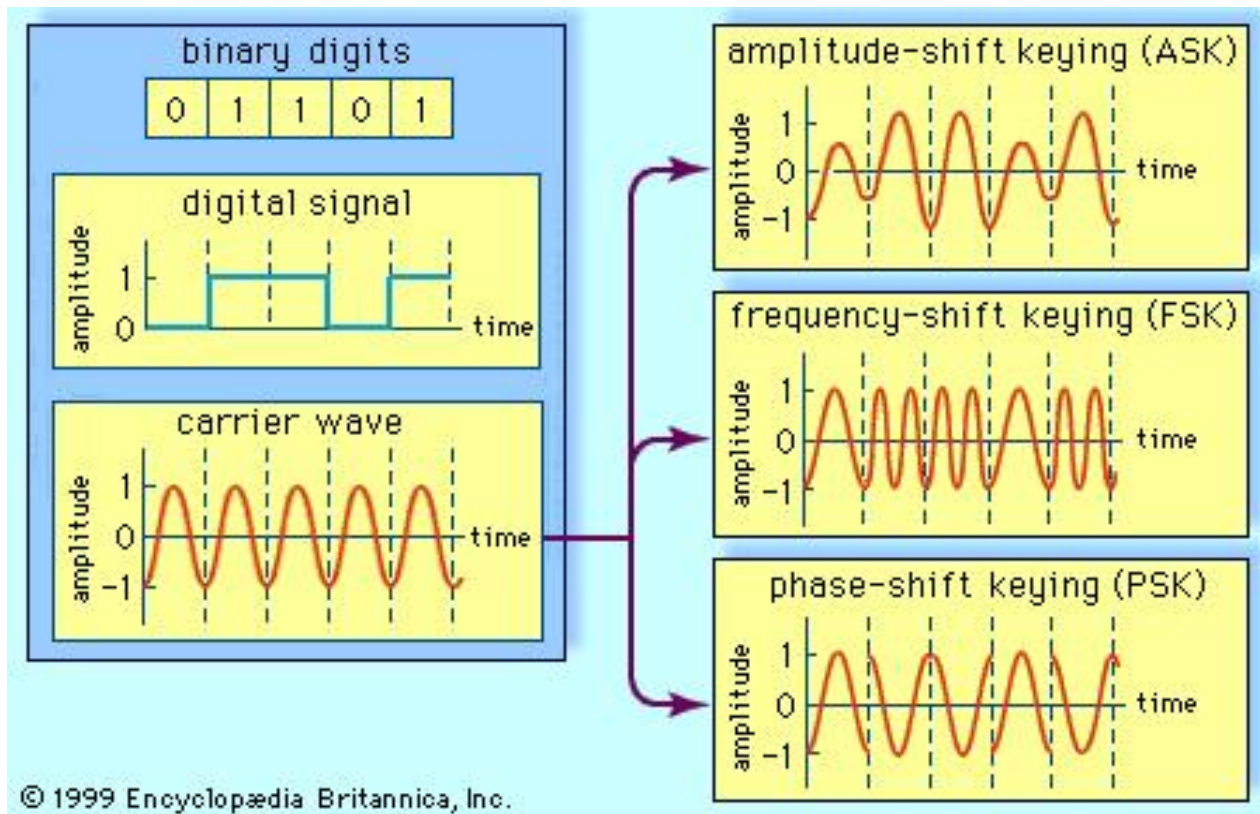

Signal processing elements  
Propagation and radio communications  
Engineering

Signal  $\equiv$  information!  
Source coding (dealing with the information content)  
Modulation  
Multiplexing

## Outline

- 1 Signal processing elements
  - Signal  $\equiv$  information!
  - Source coding (dealing with the information content)
  - Modulation
  - Multiplexing
- 2 Propagation and radio communications
  - Introduction to radio communications
  - Radiowave propagation
  - Examples of antennas
- 3 Engineering
  - Noise
  - Link budget

# Multiplexing: combining several sources

Mechanisms to share resources between users:

- Frequency Division Multiplexing (FDM)
- Time Division Multiplexing (TDM)
- Code Division Multiplexing (CDM)
- Space Division Multiplexing
- + combinations !

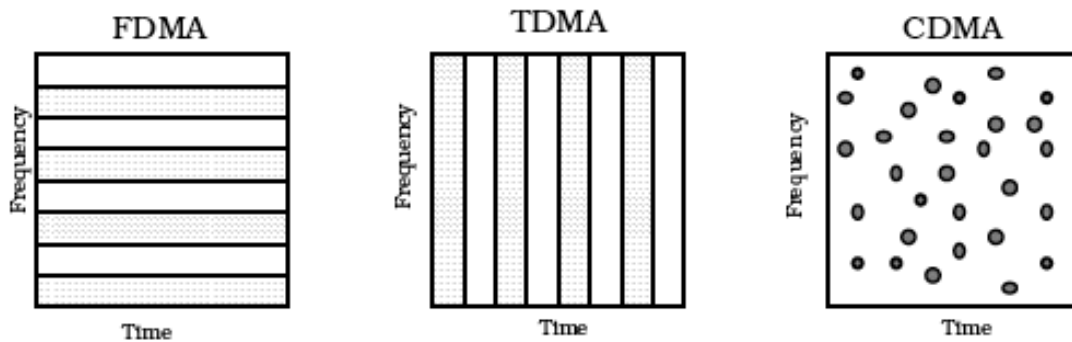

## Frequency Division Multiplexing (FDM)

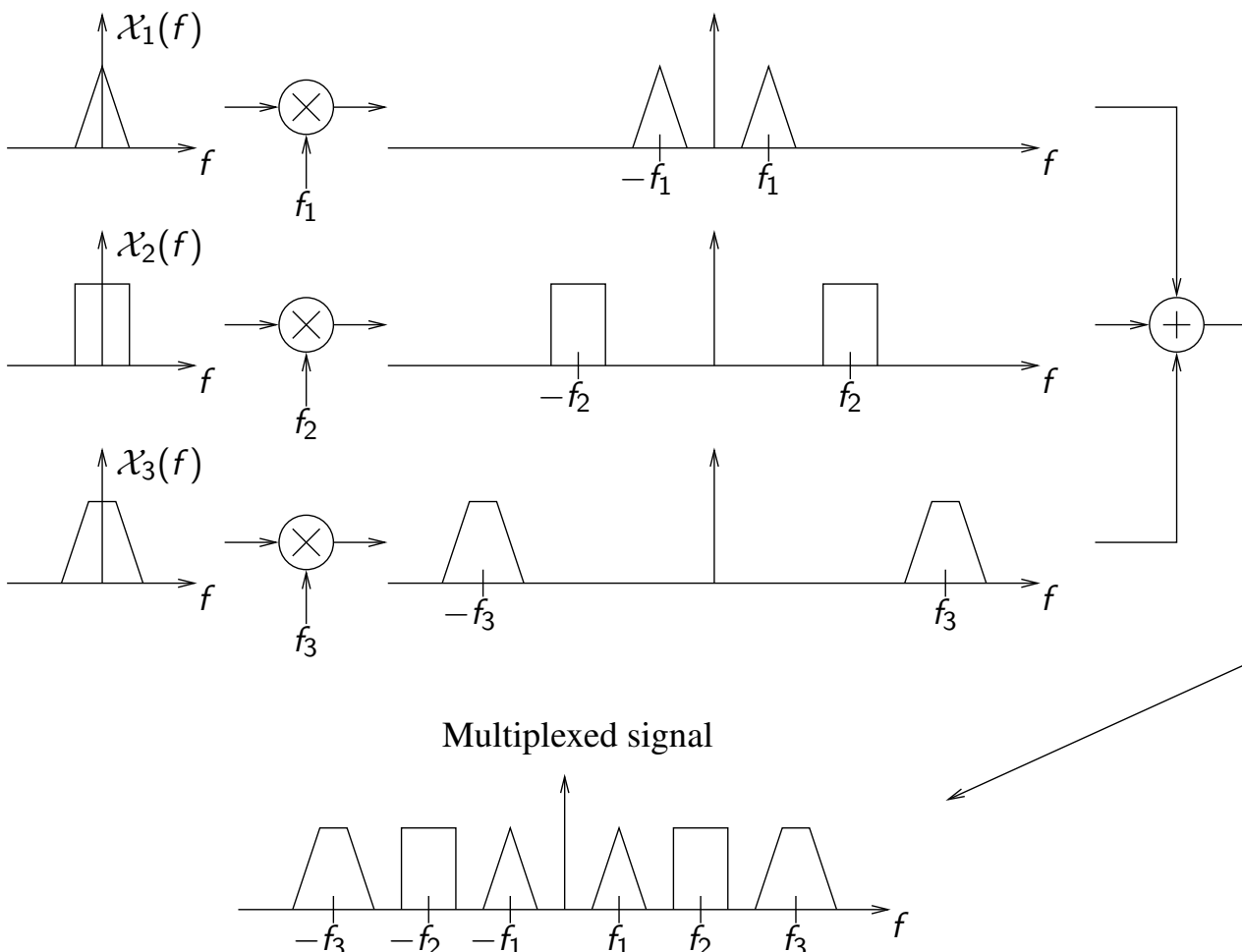

# Demultiplexing

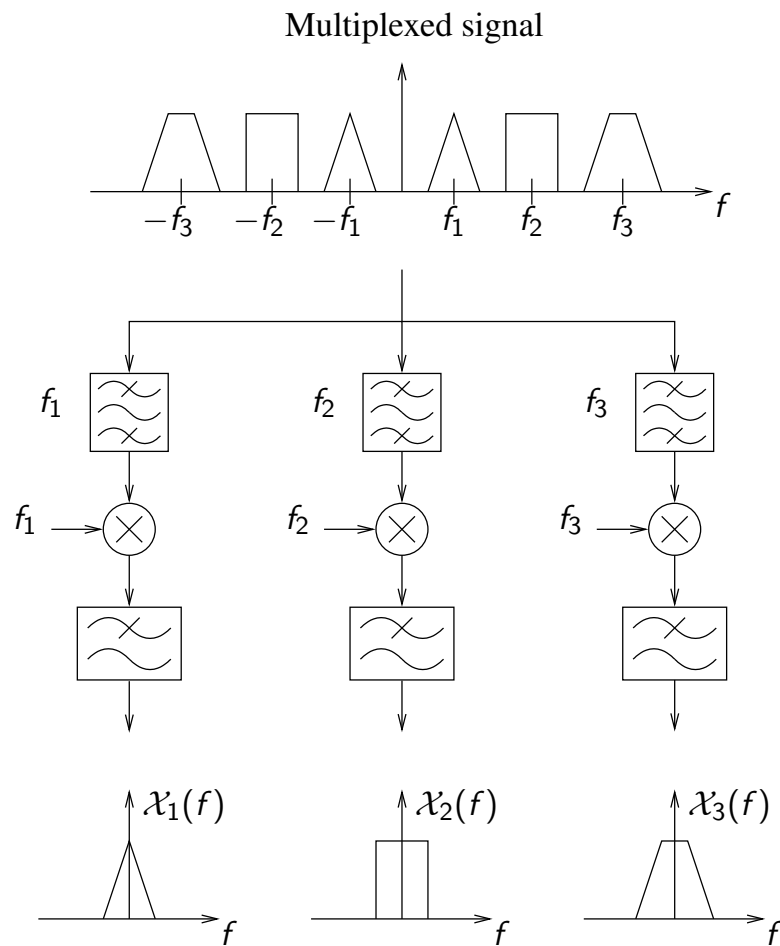

# Time Division Multiplexing (TDM)

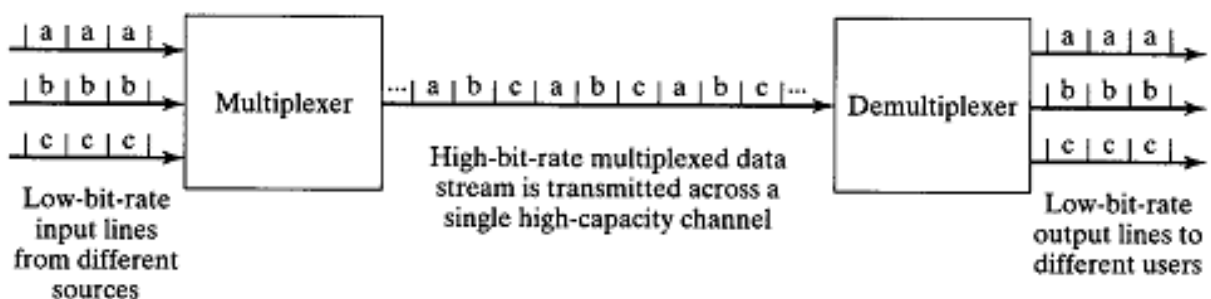
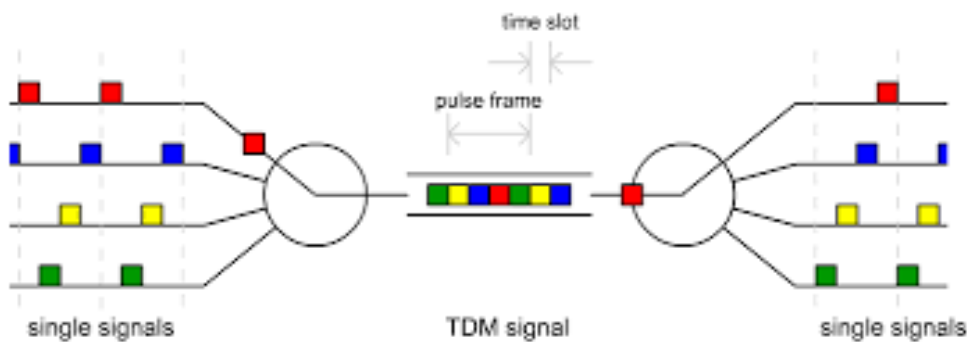

# Spread spectrum for Code Division Multiplexing

Principle of spread spectrum: multiply a digital signal with a faster pseudo-random sequence (**spreading** step)

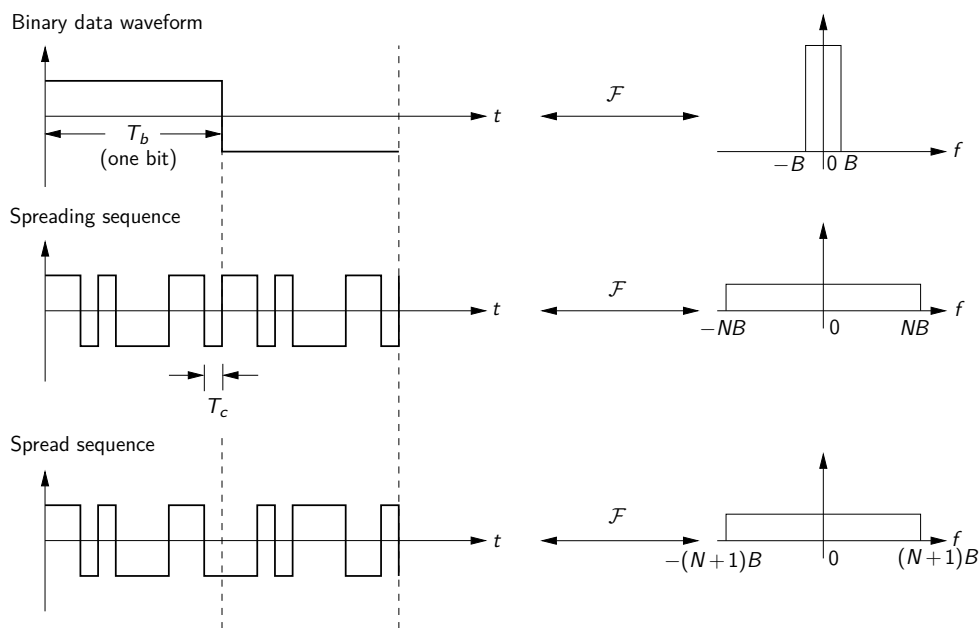

At the receiver, the same, synchronized, pseudo-random sequence is generated and used to “despread” the signal (**despreading** step)

## Code Division Multiple Access

- Each user is given its own code (multiple codes can be used simultaneously).
- All the users occupy the same bandwidth

→ very convenient when the number of users is dynamic

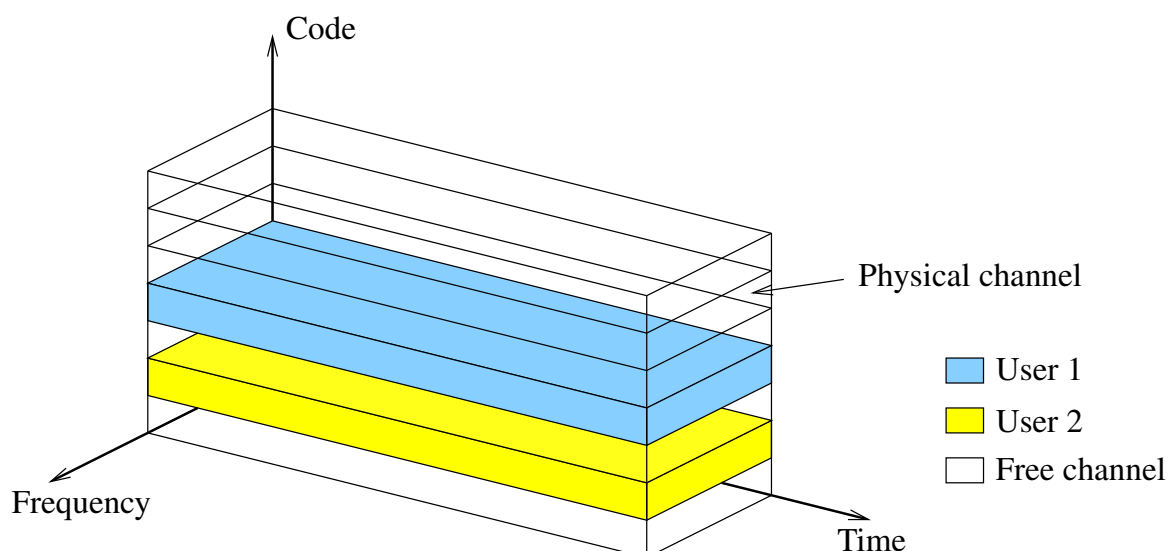



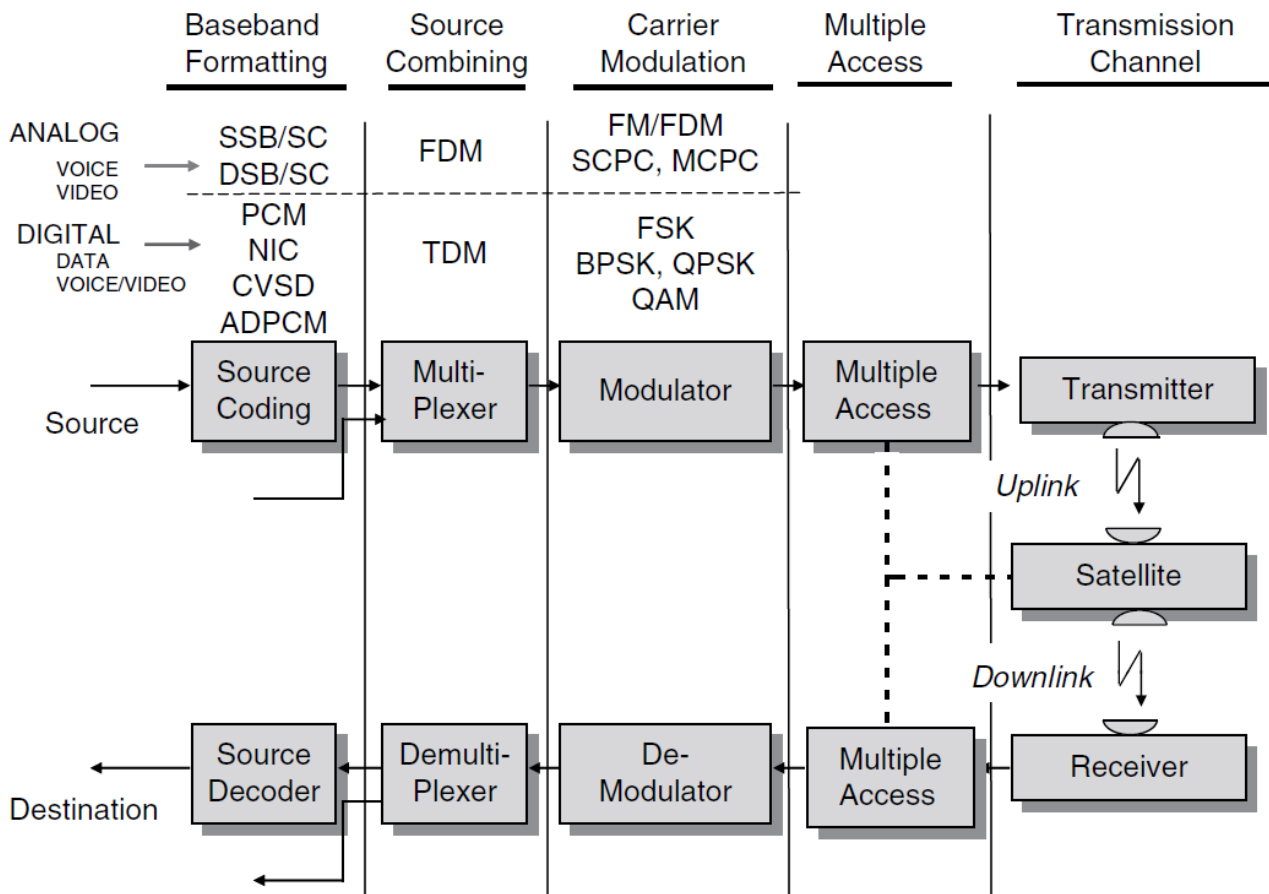

## Outline

- 1 Signal processing elements
  - Signal  $\equiv$  information!
  - Source coding (dealing with the information content)
  - Modulation
  - Multiplexing
- 2 Propagation and radio communications
  - Introduction to radio communications
  - Radiowave propagation
  - Examples of antennas
- 3 Engineering
  - Noise
  - Link budget

# Satellite link definition

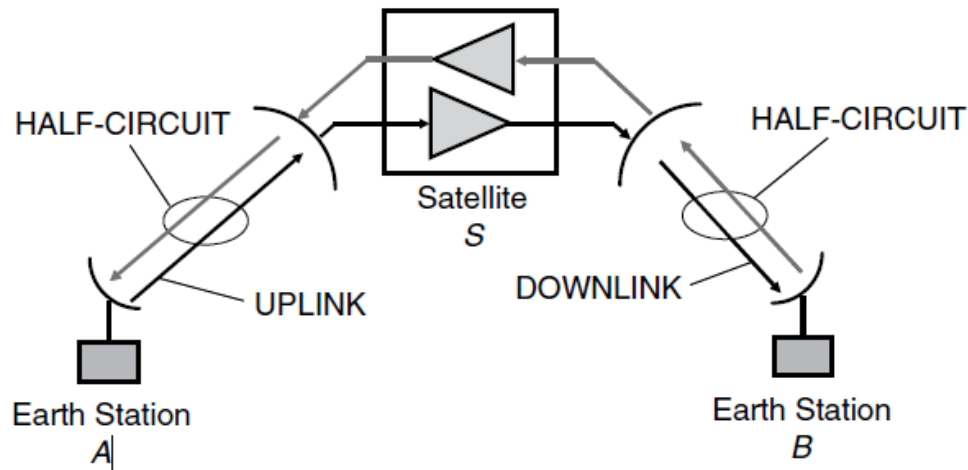

- CHANNEL – one way link from  $A \rightarrow B$  or  $B \rightarrow A$
- CIRCUIT – full duplex link –  $A \leftrightarrow B$
- HALF CIRCUIT – two way link –  $A \leftrightarrow S$  or  $S \leftrightarrow B$
- TRANSPONDER – basic satellite repeater electronics, usually one channel

# Frequency bands

Frequency (GHz)

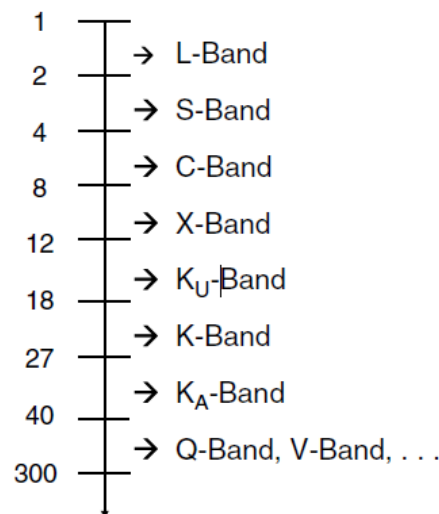

But it is also common to designate the **carrier frequency** and **bandwidth** directly.

# Regulatory bodies

- International Telecommunications Union (ITU):  
Radio-communications Sector (ITU-R)
  - service regions

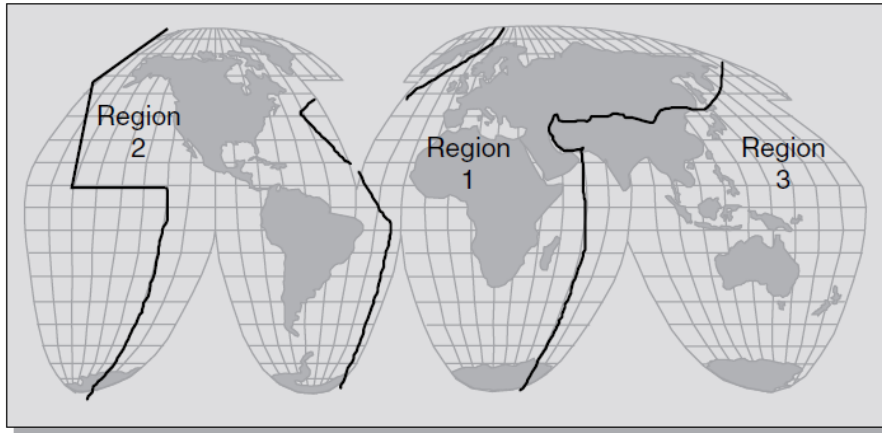

- organizes WARC (World Administrative Radio Conference) - worldwide allocation of frequencies
- Regional body: European Conference of Postal and Telecommunications Administrations (CEPT)



## Excerpt of the allocation plan/radio spectrum (by the ITU)

1610-1670 MHz (UHF)					Remarks
International Table			United States Table		
Region 1	Region 2	Region 3	Federal Government	Non-Federal Government	
1610-1610.6 MOBILE-SATELLITE (Earth-to-space) AERONAUTICAL RADIONAVIGATION  S5.341 S5.355 S5.359 S5.363 S5.364 S5.366 S5.367 S5.368 S5.369 S5.371 S5.372	1610-1610.6 MOBILE-SATELLITE (Earth-to-space) AERONAUTICAL RADIONAVIGATION RADIODETERMINATION- SATELLITE (Earth-to- space)  S5.341 S5.364 S5.366 S5.367 S5.368 S5.370 S5.372	1610-1610.6 MOBILE-SATELLITE (Earth-to-space) AERONAUTICAL RADIONAVIGATION Radiodetermination-Satellite (Earth-to-space)  S5.341 S5.355 S5.359 S5.364 S5.366 S5.367 S5.368 S5.369 S5.372	1610-1610.6 MOBILE-SATELLITE (Earth-to-space) US319 AERONAUTICAL RADIONAVIGATION US260 RADIODETERMINATION-SATELLITE (Earth-to-space)  S5.341 S5.364 S5.366 S5.367 S5.368 S5.372 US208	Satellite Communications (25) Aviation (87)	
1610.6-1613.8 MOBILE-SATELLITE (Earth-to-space) RADIO ASTRONOMY AERONAUTICAL RADIONAVIGATION  S5.149 S5.341 S5.355 S5.359 S5.363 S5.364 S5.366 S5.367 S5.368 S5.369 S5.371 S5.372	1610.6-1613.8 MOBILE-SATELLITE (Earth-to-space) RADIO ASTRONOMY AERONAUTICAL RADIONAVIGATION RADIODETERMINATION- SATELLITE (Earth-to- space)  S5.149 S5.341 S5.364 S5.366 S5.367 S5.368 S5.370 S5.372	1610.6-1613.8 MOBILE-SATELLITE (Earth-to-space) RADIO ASTRONOMY AERONAUTICAL RADIONAVIGATION Radiodetermination-satellite (Earth-to-space)  S5.149 S5.341 S5.355 S5.359 S5.364 S5.366 S5.367 S5.368 S5.369 S5.372	1610.6-1613.8 MOBILE-SATELLITE (Earth-to-space) US319 RADIO ASTRONOMY AERONAUTICAL RADIONAVIGATION US260 RADIODETERMINATION-SATELLITE (Earth-to-space)  S5.341 S5.364 S5.366 S5.367 S5.368 S5.372 US208		
1613.8-1626.5 MOBILE-SATELLITE (Earth-to-space) AERONAUTICAL RADIONAVIGATION Mobile-satellite (space-to-Earth)  S5.341 S5.355 S5.359 S5.363 S5.364 S5.365 S5.366 S5.367 S5.368 S5.369 S5.371 S5.372	1613.8-1626.5 MOBILE-SATELLITE (Earth-to-space) AERONAUTICAL RADIONAVIGATION RADIODETERMINATION- SATELLITE (Earth-to- space) Mobile-satellite (space-to- Earth)  S5.341 S5.364 S5.365 S5.366 S5.367 S5.368 S5.370 S5.372	1613.8-1626.5 MOBILE-SATELLITE (Earth-to-space) AERONAUTICAL RADIONAVIGATION Mobile-satellite (space-to- Earth) Radiodetermination- satellite (Earth-to-space)  S5.341 S5.355 S5.359 S5.364 S5.365 S5.366 S5.367 S5.368 S5.369 S5.372	1613.8-1626.5 MOBILE-SATELLITE (Earth-to-space) US319 AERONAUTICAL RADIONAVIGATION US260 RADIODETERMINATION-SATELLITE (Earth-to-space) Mobile-satellite (space-to-Earth)  S5.341 S5.364 S5.365 S5.366 S5.367 S5.368 S5.372 US208		



# Frequency allocations (see [2])

Radio-communications service	Typical up/down link	Terminology
Fixed satellite service (FSS)	6/4 [GHz]	C band
	8/7 [GHz]	X band
	14/12.1 [GHz]	Ku band
	30/20 [GHz]	Ka band
	50/40 [GHz]	V band
Mobile satellite service (MSS)	1.6/1.5 [GHz]	L band
	30/20 [GHz]	Ka band
Broadcasting satellite service (BSS)	2/2.2 [GHzz]	S band
	12 [GHzz]	Ku band
	2.6/2.5 [GHz]	S band

- Note that *frequencies for down links are usually lower than for up links*: this is because **the power loss increases with the frequency**.
- The *use of higher frequencies* allows larger bandwidths, better tracking capability, and minimizes ionospheric effects. But it also requires greater pointing accuracy



# Frequency allocations (see [2])

Radio-communications service	Typical up/down link	Terminology
Fixed satellite service (FSS)	6/4 [GHz]	C band
	8/7 [GHz]	X band
	14/12.1 [GHz]	Ku band
	30/20 [GHz]	Ka band
	50/40 [GHz]	V band
Mobile satellite service (MSS)	1.6/1.5 [GHz]	L band
	30/20 [GHz]	Ka band
Broadcasting satellite service (BSS)	2/2.2 [GHzz]	S band
	12 [GHzz]	Ku band
	2.6/2.5 [GHz]	S band

- Note that *frequencies for down links are usually lower than for up links*: this is because **the power loss increases with the frequency**.
- The *use of higher frequencies* allows larger bandwidths, better tracking capability, and minimizes ionospheric effects. But it also requires greater pointing accuracy



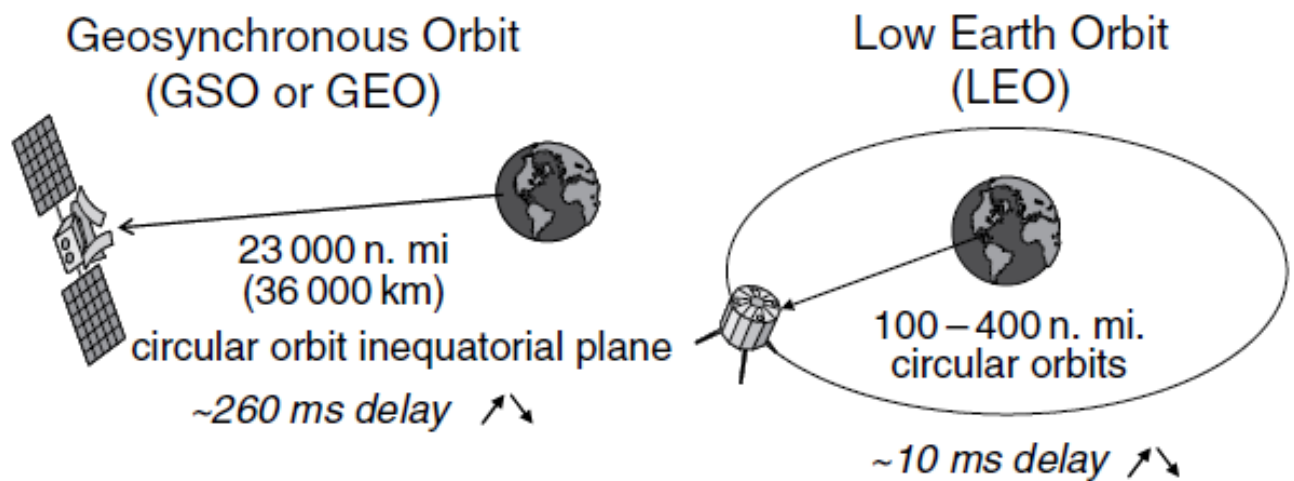

Engineering considerations:

- **distance** between user and satellite.
  - delay (increases with the distance)
  - attenuation of the signal (increases with the distance)
- **relative position** of the user/satellite pair (orientation)



Signal processing elements  
Propagation and radio communications  
Engineering

Introduction to radio communications  
Radiowave propagation  
Examples of antennas

## Outline

- 1 Signal processing elements
  - Signal  $\equiv$  information!
  - Source coding (dealing with the information content)
  - Modulation
  - Multiplexing
- 2 Propagation and radio communications
  - Introduction to radio communications
  - Radiowave propagation
  - Examples of antennas
- 3 Engineering
  - Noise
  - Link budget



# Radiowave propagation

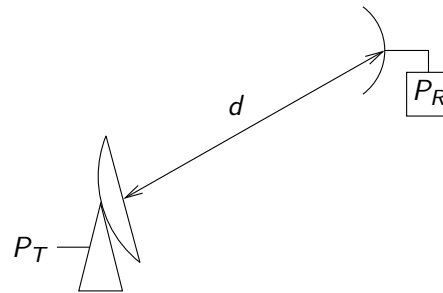

Important issues:

- channel characteristics
  - attenuation (distance)
  - atmospheric effects
    - wave polarization
    - rain mitigation
- antenna design
- power budget (related to the Signal to Noise ratio)



## Two main types of radiation pattern

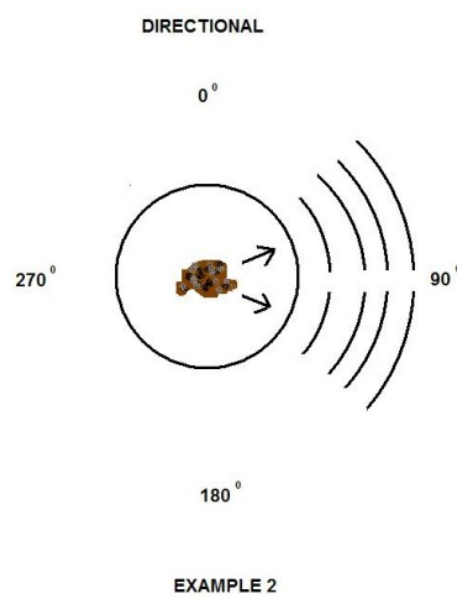
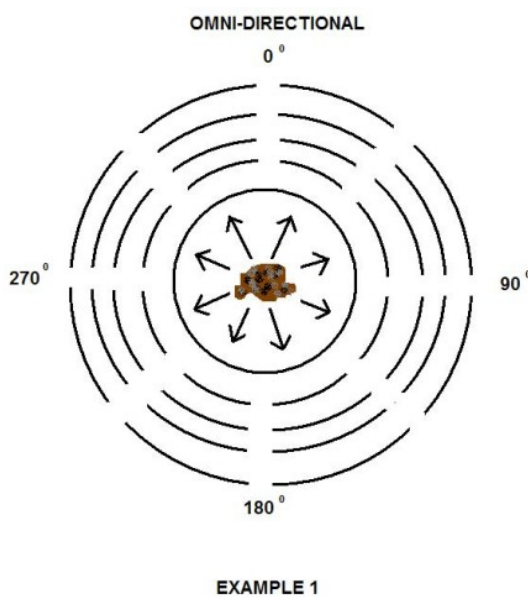



## Theorem (Reciprocity for antennas)

The electrical characteristics of an antenna such as gain, radiation pattern, impedance, bandwidth, resonant frequency and polarization, are the same whether the antenna is transmitting ( $T$ ) or receiving ( $R$ ).

## Theorem (Strong reciprocity)

If a voltage is applied to an antenna  $A$  and the current is measured at another antenna  $B$ , then an equal current (in both amplitude and phase) will appear at  $A$  if the same voltage is applied to  $B$ .

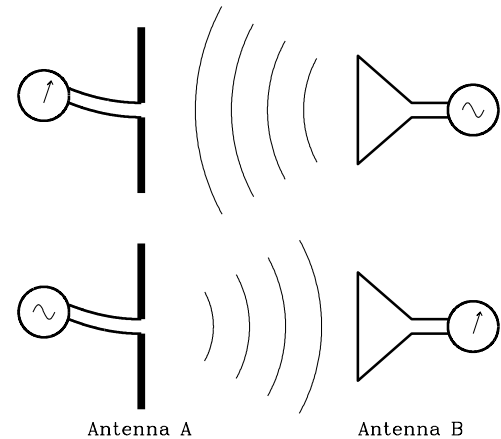

## Inverse square law of radiation

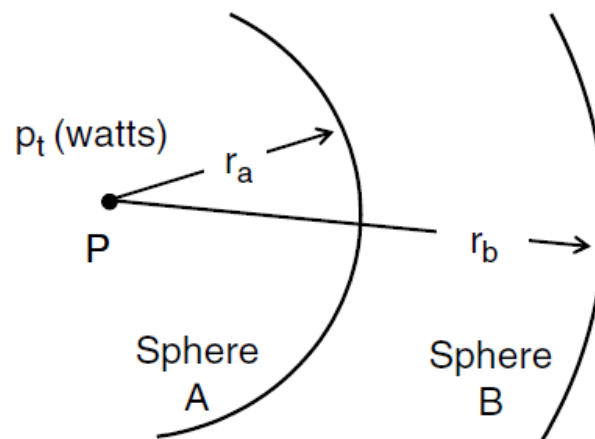

The **power flux density** (or **power density**)  $S$ , over the surface of a sphere of radius  $r_a$  from the point  $P$ , is given by (POYNTING vector)

$$S_a = \frac{P_t}{4\pi r_a^2} \left[ \frac{\text{W}}{\text{m}^2} \right] \quad (6)$$



# Effective Isotropic Radiated Power [EIRP]

## Definition (EIRP)

The **Effective Isotropic Radiated Power (EIRP)** of a transmitter is the power that the transmitter appears to have if the transmitter were an isotropic radiator (if the antenna radiated equally in all directions).

From the receiver's point of view,

$$P_t = P_T G_T \quad (7)$$

where:

- $P_t$  is the power of a fictive isotropic antenna.
- $P_T$  is the transmitter power and  $G_T$  is its gain (in that direction).

If the cable losses can be neglected, then  $\text{EIRP} = P_T G_T$ .



# Effective area

## Definition (Effective area)

The **effective area** of an antenna is the ratio of the available power to the power flux density (POYNTING vector):

$$A_{\text{eff},R} = \frac{P_R}{S_{\text{eff},R}} \quad (8)$$

## Theorem ((no proof given))

The **effective area** of an antenna is related to its **gain** by the following formula

$$A_{\text{eff},R} = G_R \frac{\lambda^2}{4\pi} \quad (9)$$

By reciprocity, all these results are equally valid for a transmitting antenna  $T$ .



# Friis's relationship

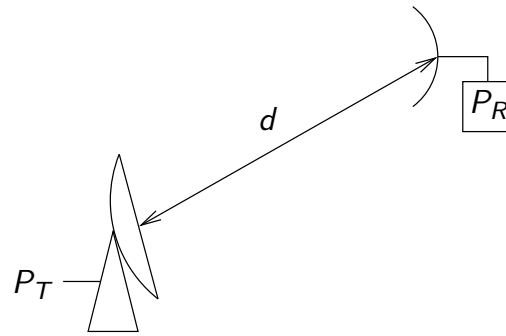

We have

$$P_R = S_{\text{eff},R} A_{\text{eff},R}$$

$$= \left( \frac{P_T G_T}{4\pi d^2} \right) A_{\text{eff},R} = \left( \frac{P_T G_T}{4\pi d^2} \right) \left( \frac{\lambda^2}{4\pi} \right) G_R = P_T G_T G_R \left( \frac{\lambda}{4\pi d} \right)^2$$

Free space path loss	FRIIS's relationship
$L_{FS} = \left( \frac{\lambda}{4\pi d} \right)^2$	$\epsilon = \frac{P_T}{P_R} = \left( \frac{4\pi d}{\lambda} \right)^2 \frac{1}{G_T G_R}$



## Decibel as a common power unit

$$x \leftrightarrow 10 \log_{10}(x) [\text{dB}] \quad (10)$$

$x$ [W]	$10 \log_{10}(x)$ [dBW]
1 [W]	0 [dBW]
2 [W]	3 [dBW]
0,5 [W]	-3 [dBW]
5 [W]	7 [dBW]
$10^n$ [W]	$10 \times n$ [dBW]

Orders of magnitude in satellite communications:

- transmitter power:  $100 \text{ [W]} \equiv 20 \text{ [dB]}$
- received power:  $100 \text{ [pW]} = 100 \times 10^{-12} \text{ [W]} \equiv -100 \text{ [dB]}$



$$L_{FS} = \left( \frac{\lambda}{4\pi d} \right)^2 = \left( \frac{c}{4\pi df} \right)^2 \quad (11)$$

where  $c$  is the speed of light.

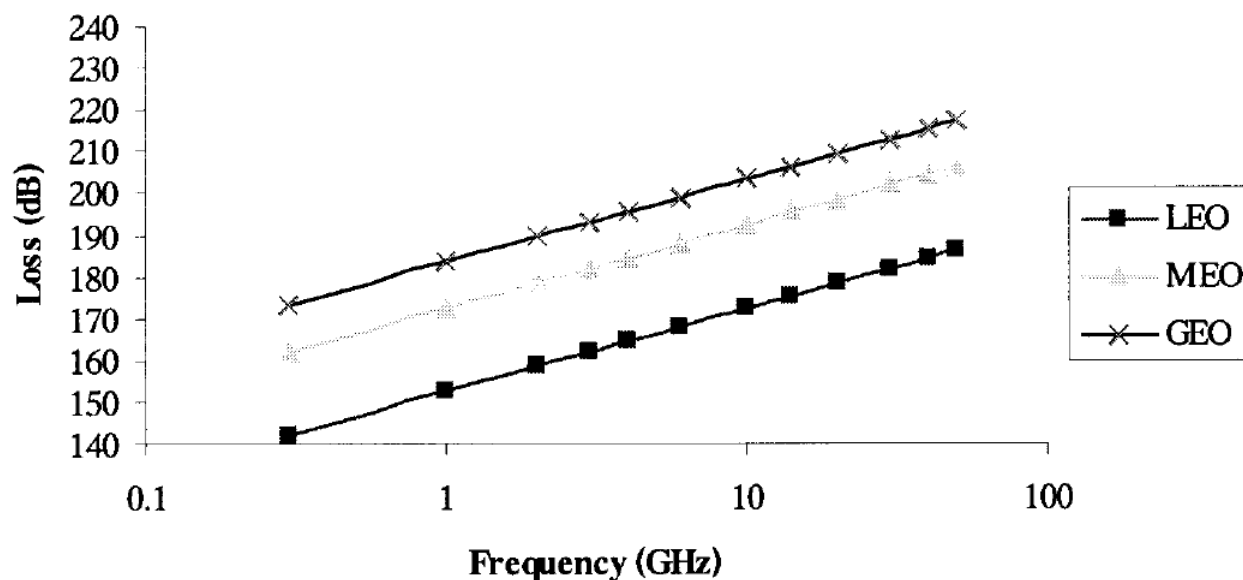

## Are high frequencies less adequate?

In [dB], Friis's relationship becomes

$$\epsilon = 32.5 + 20 \log f_{[\text{MHz}]} + 20 \log d_{[\text{km}]} - G_T[\text{dB}] - G_R[\text{dB}] \quad (12)$$

The attenuation (loss) increases with  $f$ . So ?!

In fact,  $G_T[\text{dB}]$  and  $G_R[\text{dB}]$  also depend on the frequency; the gains increase with the frequency.

There is thus a trade-off, that depends on the antenna gains!

In the end, the attenuation still increases with the frequency but not as fast as  $20 \log f_{[\text{MHz}]}$ .

# Are high frequencies less adequate?

In [dB], Friis's relationship becomes

$$\epsilon = 32.5 + 20 \log f_{[\text{MHz}]} + 20 \log d_{[\text{km}]} - G_T[\text{dB}] - G_R[\text{dB}] \quad (12)$$

The attenuation (loss) increases with  $f$ . So ?!

In fact,  $G_T[\text{dB}]$  and  $G_R[\text{dB}]$  also depend on the frequency; the gains increase with the frequency.

There is thus a trade-off, that depends on the antenna gains!

In the end, the attenuation still increases with the frequency but not as fast as  $20 \log f_{[\text{MHz}]}$ .

## Practical case: VSAT in the Ku-band (see [1])

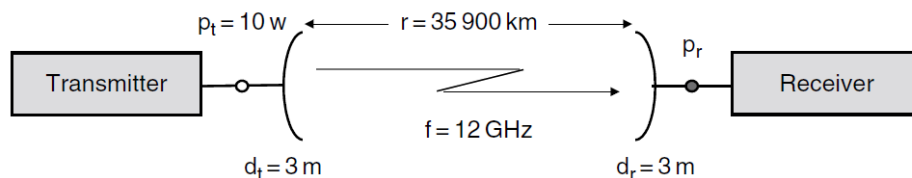

Antenna gains: 48.93 [dB]

The free space path loss is, in [dB],

$$L_{FS} = 32.5 + 20 \log f_{[\text{MHz}]} + 20 \log d_{[\text{km}]} = 205.1 \text{ [dB]} \quad (13)$$

The received power is, in [dB],

$$P_R = P_T + G_T + G_R - L_{FS} \quad (14)$$

$$= 10 + 48.93 + 48.93 - 205.1 = -97.24 \text{ [dB]} \quad (15)$$

In [W], the received power is

$$P_R = 10^{-\frac{97.24}{10}} = 10^{-9.724} = 1.89 \times 10^{-10} \text{ [W]} = 189 \text{ [pW]} \quad (16)$$

# Outline

- 1 Signal processing elements
  - Signal  $\equiv$  information!
  - Source coding (dealing with the information content)
  - Modulation
  - Multiplexing
- 2 Propagation and radio communications
  - Introduction to radio communications
  - Radiowave propagation
  - Examples of antennas
- 3 Engineering
  - Noise
  - Link budget



Marc VAN DROOGENBROECK

Signal processing elements  
Propagation and radio communications  
Engineering

Satellite Communications

Introduction to radio communications  
Radiowave propagation  
Examples of antennas

# Terrestrial antennas



Marc VAN DROOGENBROECK

Satellite Communications



# Ground station antenna



## Parabolic (dish) antenna

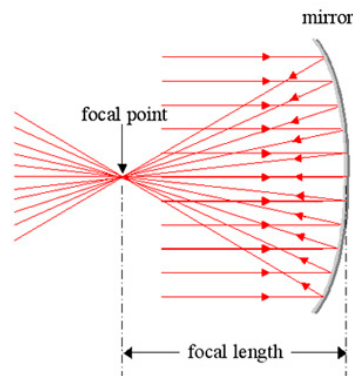

### Radiation pattern

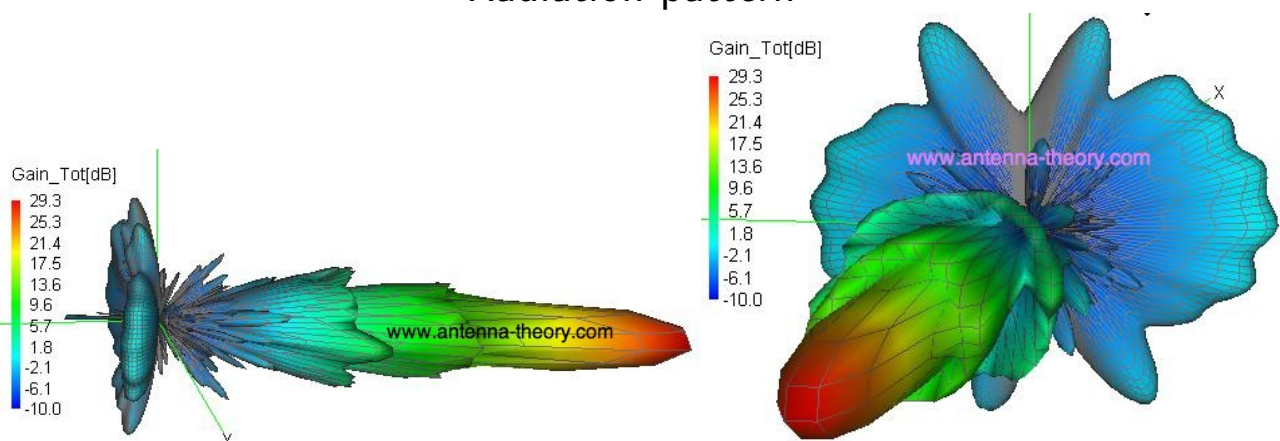

# Deployable antenna

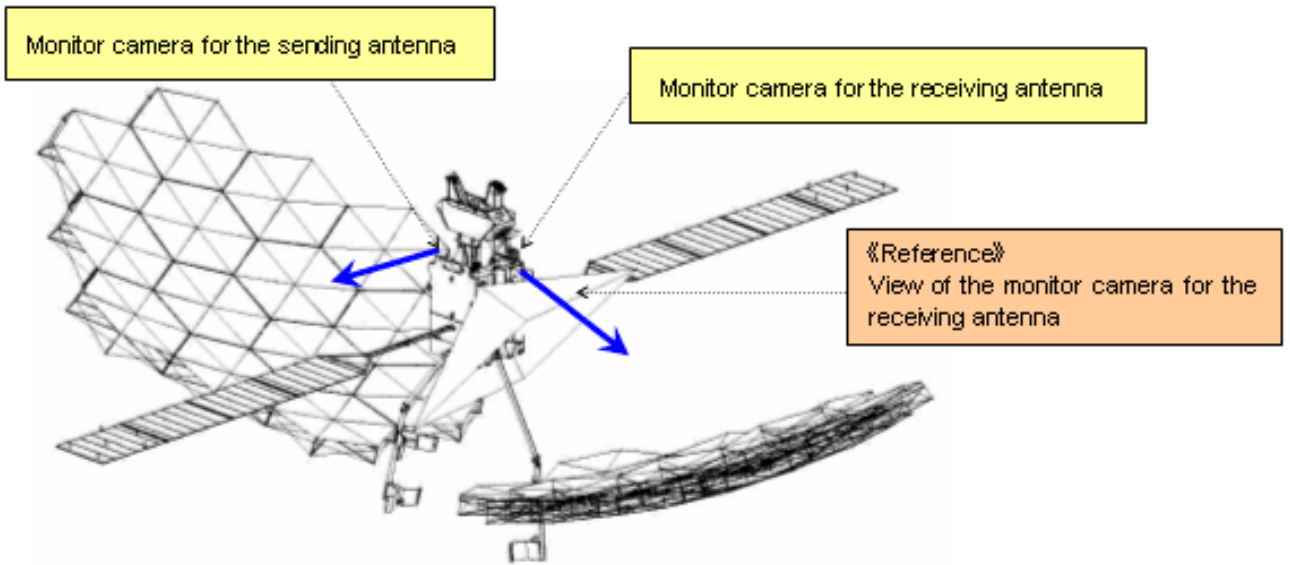

# Horn antenna and waveguide feed

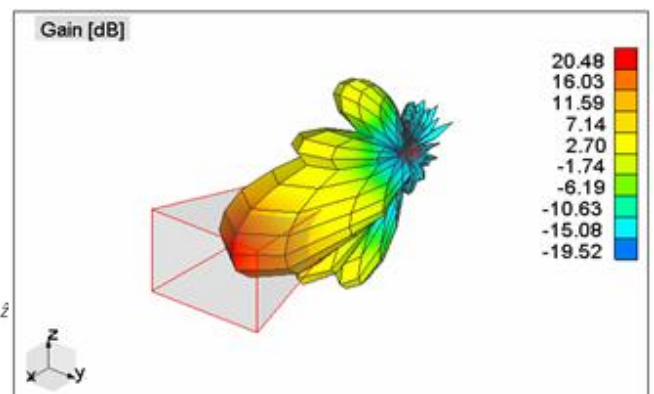
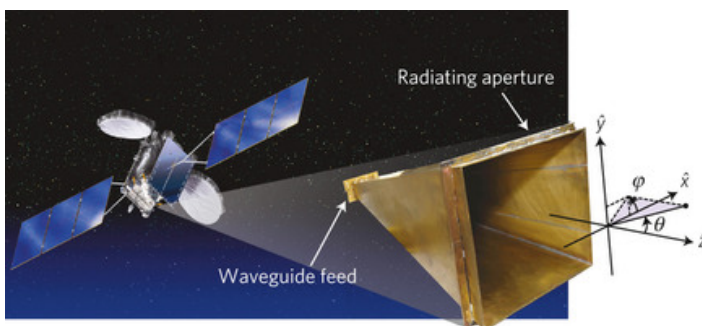

# Yagi antenna

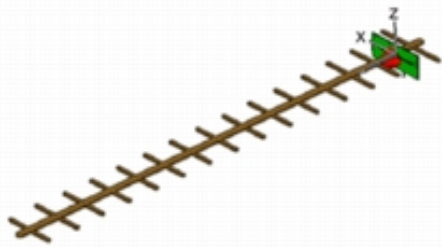

(a) Yagi Antenna Model

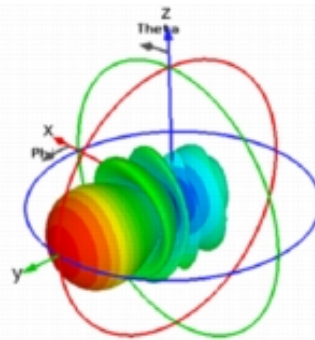

(b) Yagi Antenna 3D Radiation Pattern

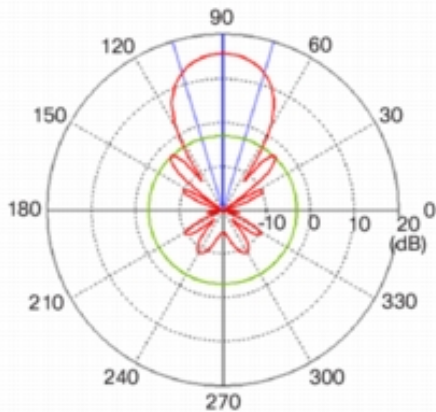

(c) Yagi Antenna Azimuth Plane Pattern

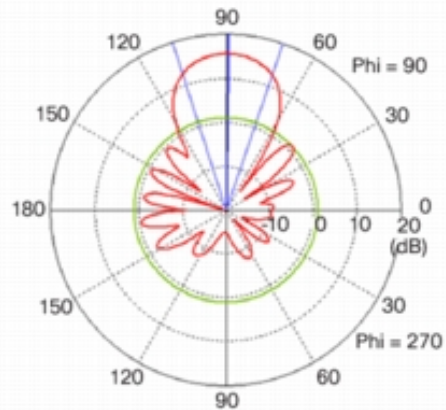

(d) Yagi Antenna Elevation Plane Pattern



# Patch array antenna

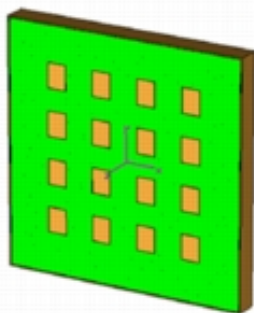

(a) 4x4 Patch Array Antenna

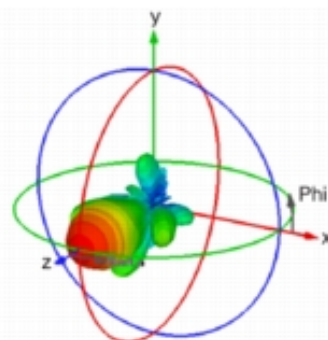

(b) 4x4 Patch Array 3D Radiation Pattern

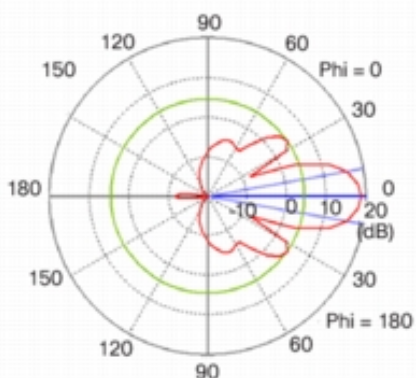

(c) 4x4 Patch Array Azimuth Plane Pattern

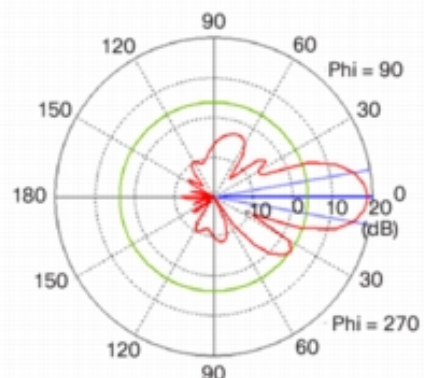

(d) 4x4 Patch Array Elevation Plane Pattern





# Phased array antenna

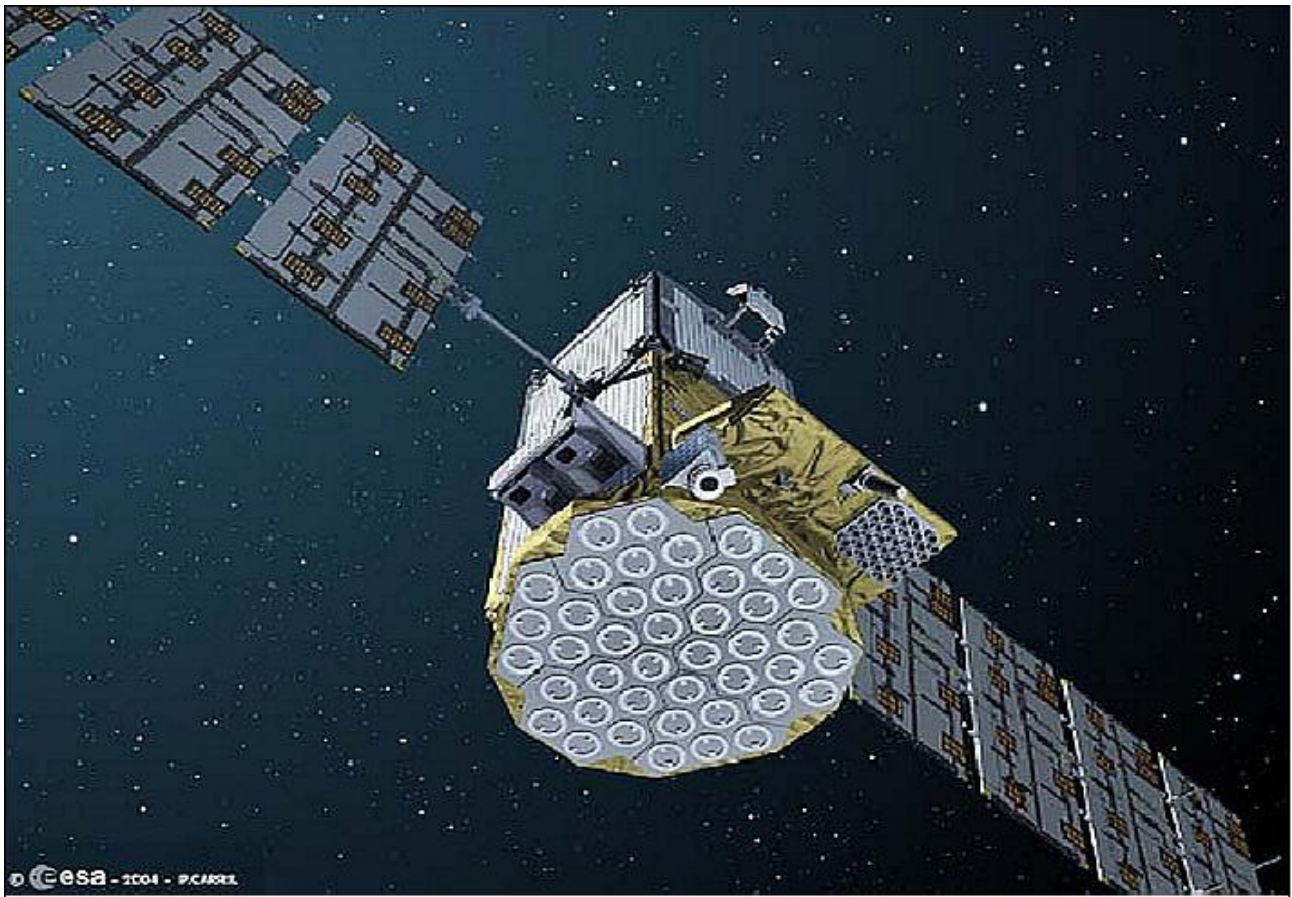

## Radiowave propagation mechanisms

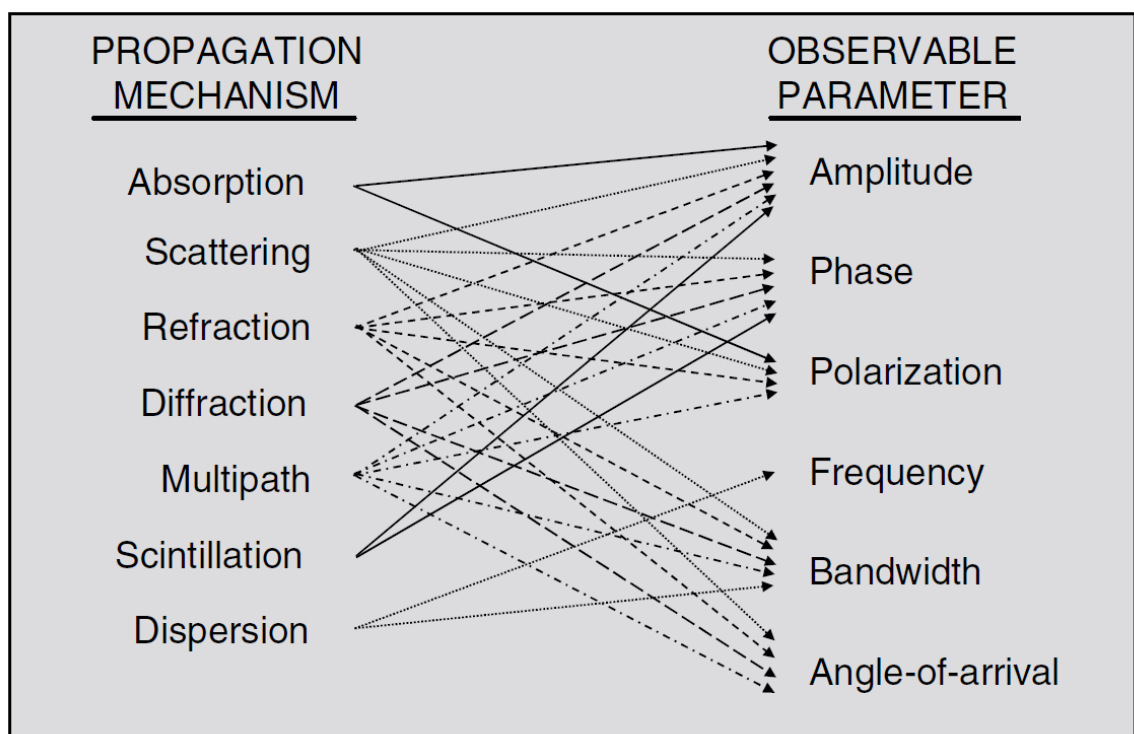

+ Doppler effect

# Earth atmosphere absorption

Expressed in terms of the wavelength:  $\lambda [m] = \frac{c}{f} = \frac{3 \times 10^8 [m/s]}{f [Hz]}$

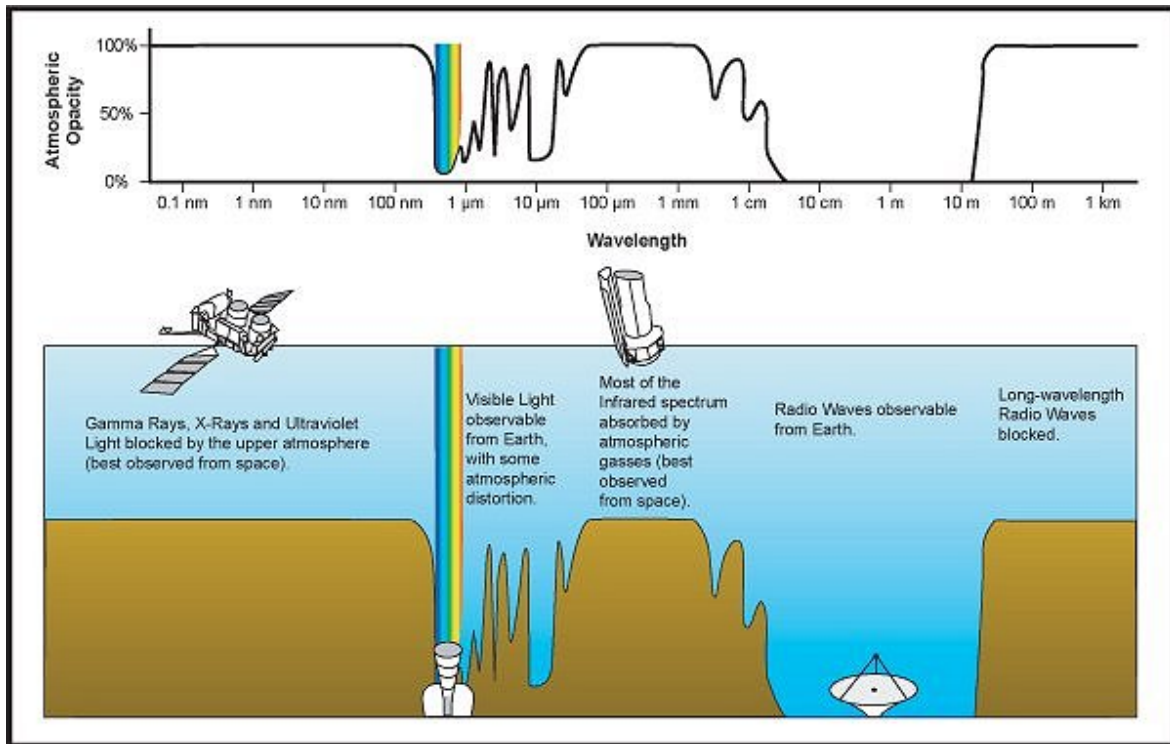

## Attenuation due to atmospheric gases

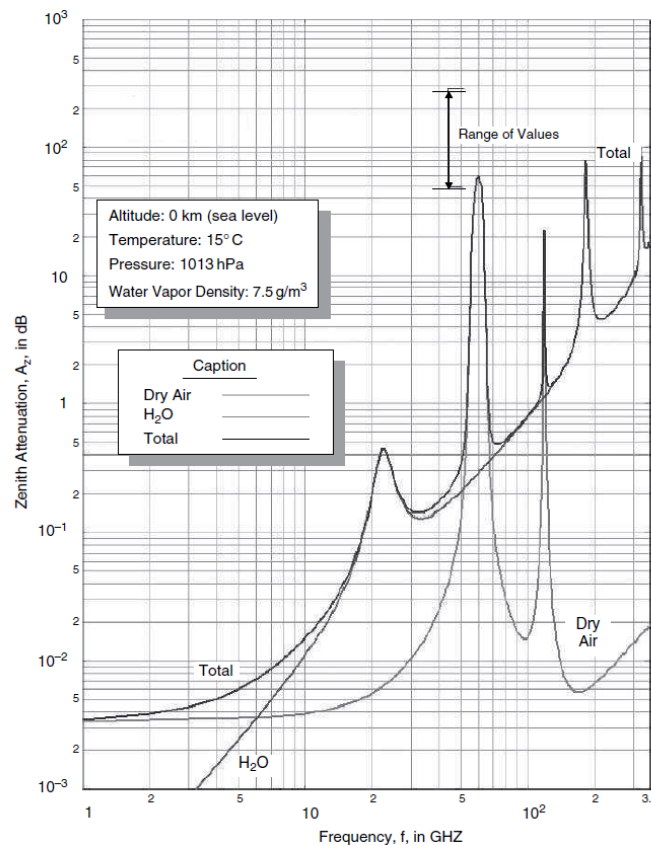

Zenith attenuation due to atmospheric gases (source: ITU-R P.676-6)  
[O<sub>2</sub> and H<sub>2</sub>O are the main contributors]

# Rain attenuation

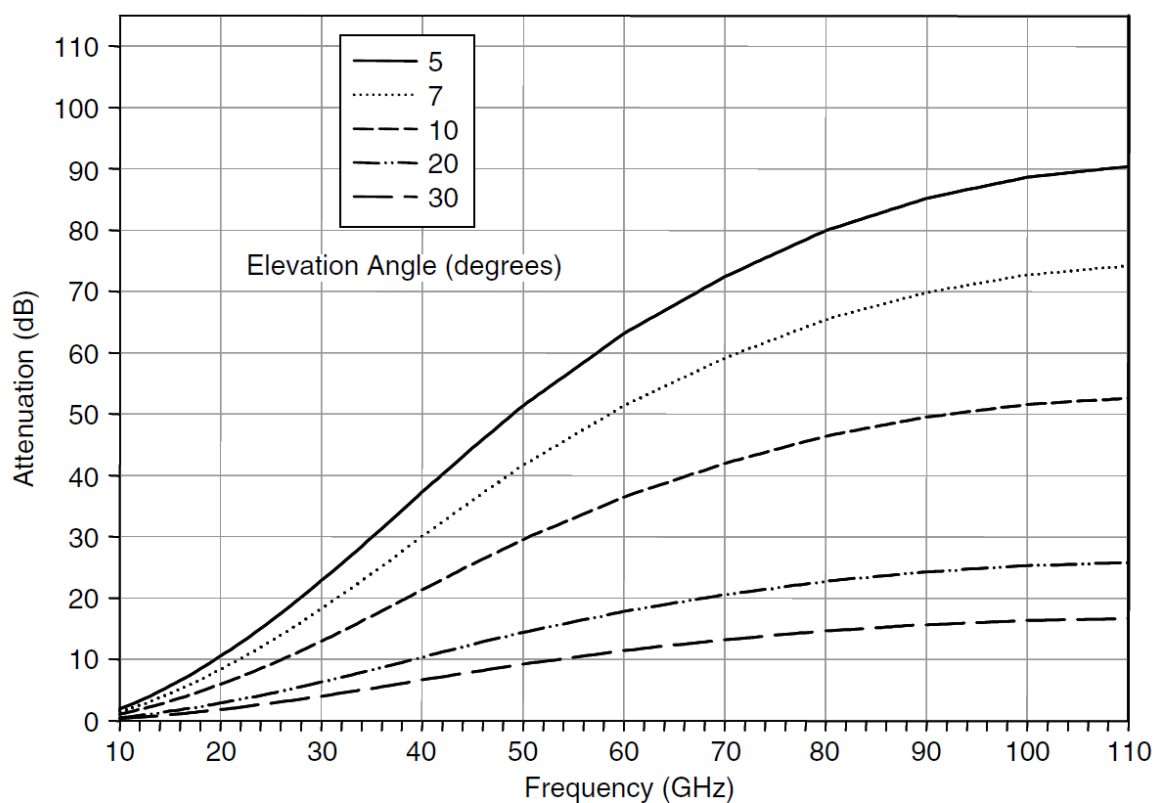

Total path rain attenuation as a function of frequency and elevation angle.  
Location: Washington, DC, Link Availability: 99%

# Cloud attenuation

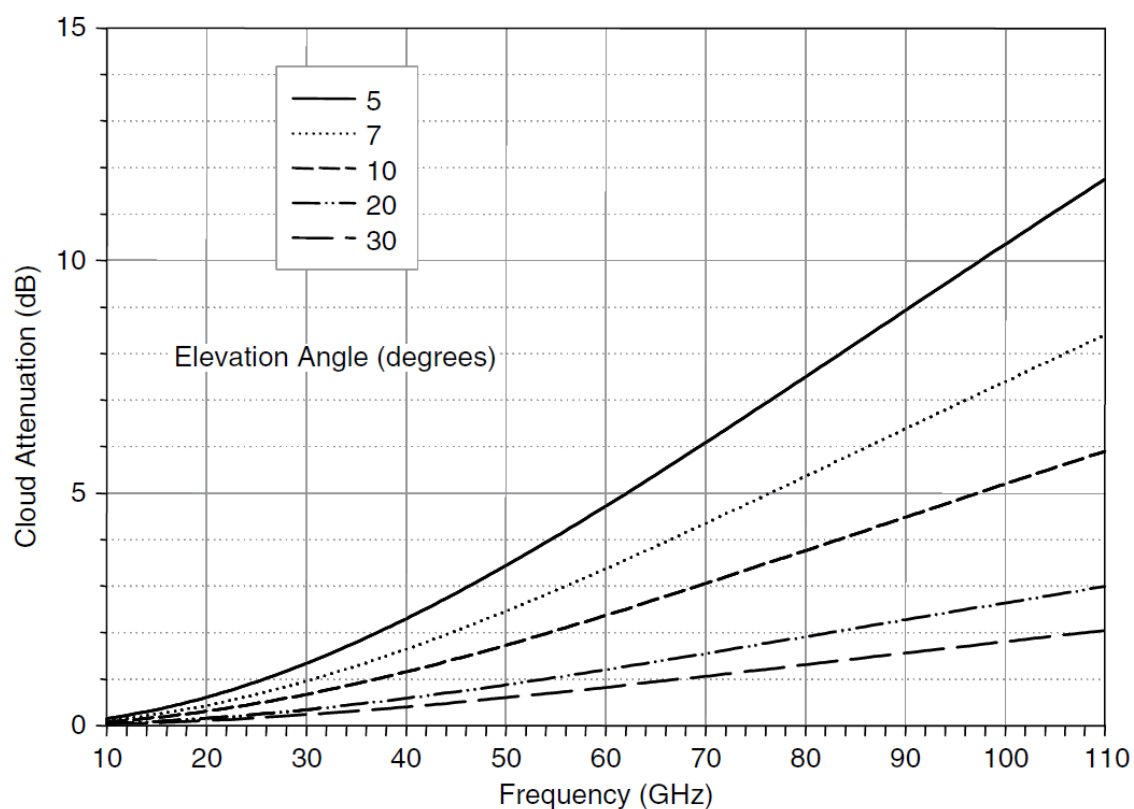

Cloud attenuation as a function of frequency, for elevation angles from 5 to 30°

The ITU recommends that all tropospheric contributions to signal attenuation are combined as follows:

$$A_T(p) = A_G(p) + \sqrt{(A_R(p) + A_c(p))^2 + A_s(p)} \quad (17)$$

where:

- $A_T(p)$  is the total attenuation for a given **probability**
- $A_G(p)$  is the attenuation due to *water vapor* and *oxygen*
- $A_R(p)$  is the attenuation due to *rain*
- $A_c(p)$  is the attenuation due to *clouds*
- $A_s(p)$  is the attenuation due to *scintillation* (rapid fluctuations attributed to irregularities in the tropospheric refractive index)

## Outline

- 1 Signal processing elements
  - Signal  $\equiv$  information!
  - Source coding (dealing with the information content)
  - Modulation
  - Multiplexing
- 2 Propagation and radio communications
  - Introduction to radio communications
  - Radiowave propagation
  - Examples of antennas
- 3 Engineering
  - Noise
  - Link budget



- ① What is the amount of **noise generated by the equipment**?
- ② In a receiver, we **cascade** filter, line, amplifier, decoder, mixer, ...
  - ① How do we characterize a **single two-port circuit** ( $\equiv$  quadripole) in terms of noise?
  - ② How do we characterize a **cascade of two-port circuits**?
- ③ **Calculate** the final **signal to noise ratio** (to determine the capacity or determine the BER, etc.).

## Noise

A natural source of noise is **thermal noise**, caused by the omnipresent **motion of free electrons in conducting material**.

Theorem (NYQUIST'S formula for a one-port noise generator)

The **available power** from a **thermal source** in a bandwidth of  $W$  is

$$P_N = k_B T W \quad (18)$$

where

- $k_B = 1,38 \times 10^{-23} [J/K]$  is the constant of BOLTZMANN ( $-198 [dBm/K/Hz] = -228.6 [dBW/K/Hz]$ )
- $T$  is the equivalent noise temperature of the noise source
- $W$  is the bandwidth of the system

Thermal noise is one the main sources of noise in a satellite  $\rightarrow$  put *electronics* in the *cold "zone" of a satellite*

# Noise in two-port circuits

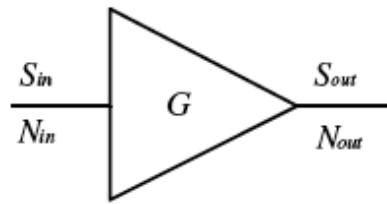

## Definitions

**Noise Factor ( $F$ ):** [provided by the manufacturer]

$$F = \frac{\left(\frac{S}{N}\right)_{in}}{\left(\frac{S}{N}\right)_{out}} > 1 \quad (19)$$

**Noise Figure (NF):**

$$NF = 10 \log_{10} F \quad (20)$$

**Effective noise temperature  $T_e$  ( $T_0 = 290$  [K]):**

$$T_e = T_0(F - 1) \quad (21)$$



## Noise factor of a two-port cascade I

In a cascade, each two-port element is noisy  $\rightarrow$  it contributes to degrade the overall noise factor

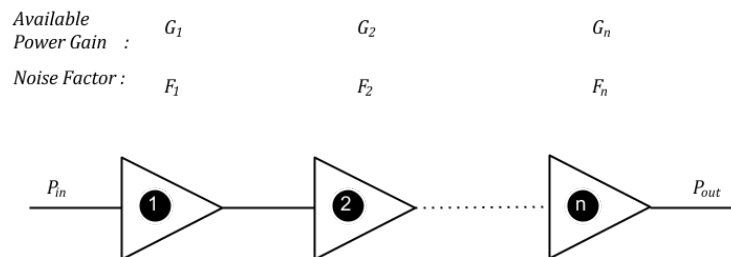

Figure: Cascading two-port elements.

For a two-port network with  $n$  stages,

$$F = F_1 + \frac{F_2 - 1}{G_1} + \frac{F_3 - 1}{G_1 G_2} + \dots = F_1 + \sum_{i=2}^n \frac{F_i - 1}{\prod_{j=1}^{i-1} G_j} \quad (22)$$



# Noise factor of a two-port cascade II

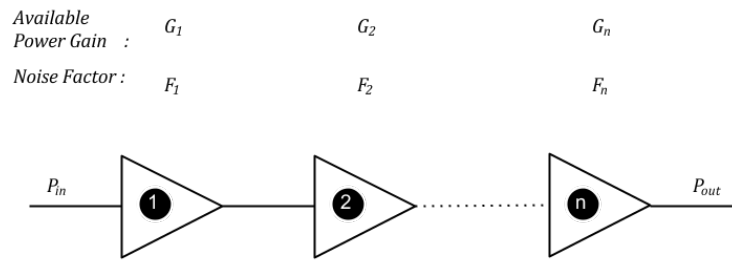

Figure: Cascading two-port elements.

Likewise,

$$T_e = T_{e1} + \frac{T_{e2}}{G_1} + \frac{T_{e3}}{G_1 G_2} + \dots = T_{e1} + \sum_{i=2}^n \frac{T_{ei}}{\prod_{j=1}^{i-1} G_j} \quad (23)$$



## Receiver front end I

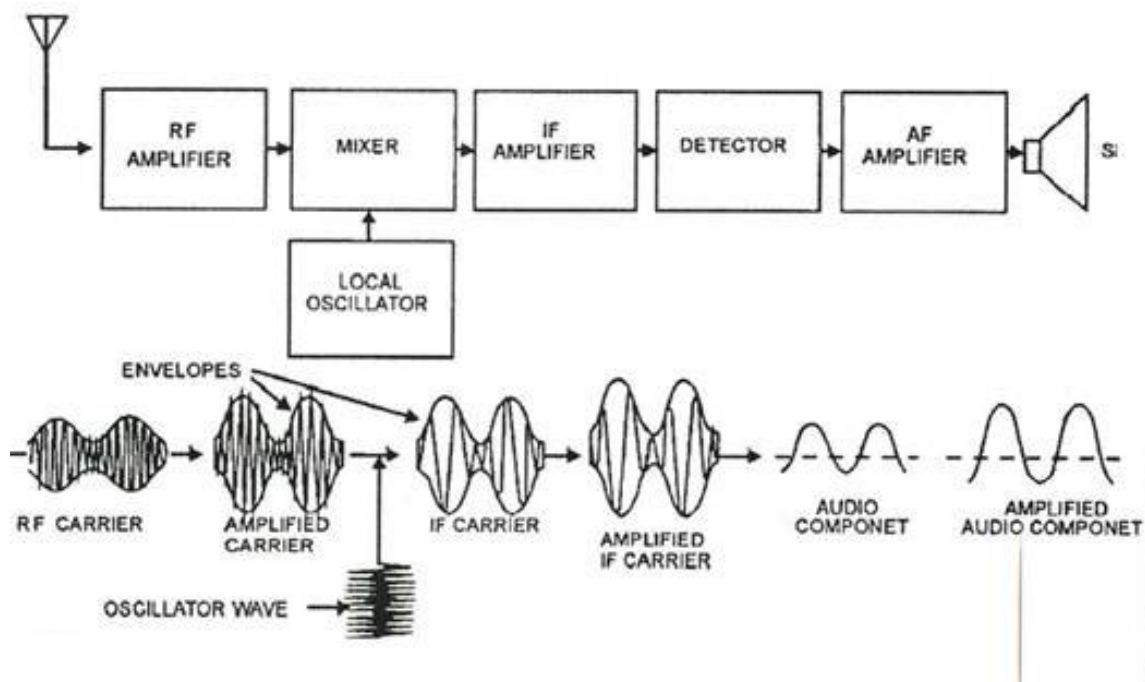
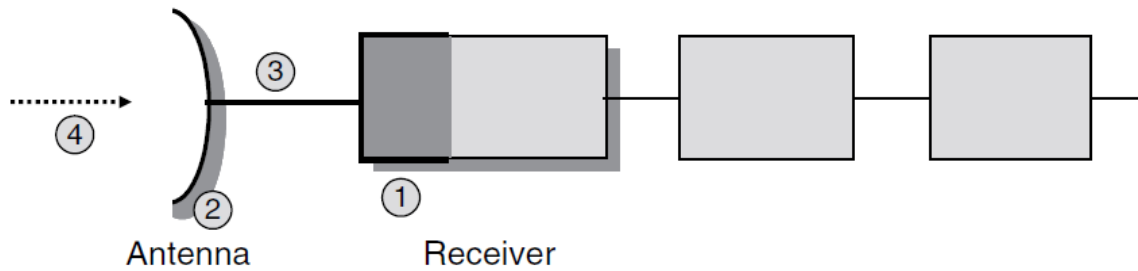

Figure: Block diagram of a typical receiver.





Rule of thumb: highest gain ( $G_1$ ) and best noise figure ( $F_1$ ) first.

Then

$$F = F_1 + \frac{F_2 - 1}{G_1} + \frac{F_3 - 1}{G_1 G_2} + \dots \simeq F_1 + \frac{F_2 - 1}{G_1} \quad (24)$$

$$T_e = T_{e1} + \frac{T_{e2}}{G_1} + \frac{T_{e3}}{G_1 G_2} + \dots \simeq T_{e1} + \frac{T_{e2}}{G_1} \quad (25)$$



## Example of the calculation of a noise budget (see [1])

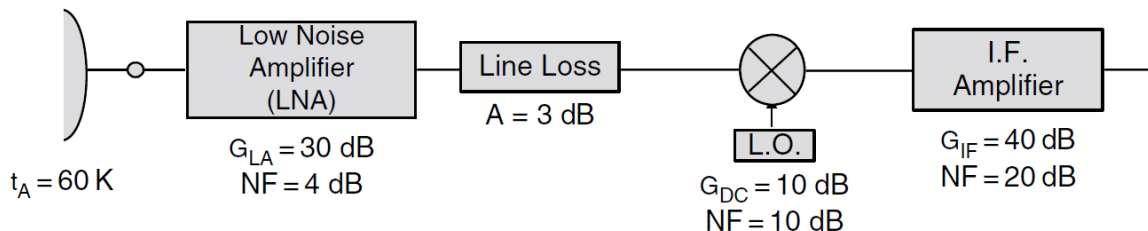

- **Low Noise Amplifier:**  $T_{LA} = 290 \times (10^{\frac{4}{10}} - 1) = 438$  [K]
- **Line.** For a *passive* two-port circuit, the noise factor is equal to the attenuation:  $F_0 = A$ .
  - $T_{Line} = 290 \times (10^{\frac{3}{10}} - 1) = 289$  [K],
  - $G_{Line} = \frac{1}{2}$

The effective noise temperature, including the **antenna noise**  $t_A$ , is

$$T_e = t_A + T_{e1} + \frac{T_{e2}}{G_1} + \frac{T_{e3}}{G_1 G_2} + \dots \quad (26)$$

$$= \underbrace{60 + 438}_{498} + \frac{289}{1000} + \frac{2610}{1000 \times \frac{1}{2}} + \dots = 509.3$$
 [K] (27)



# Typical values for the increase in antenna temperature due to rain [1]

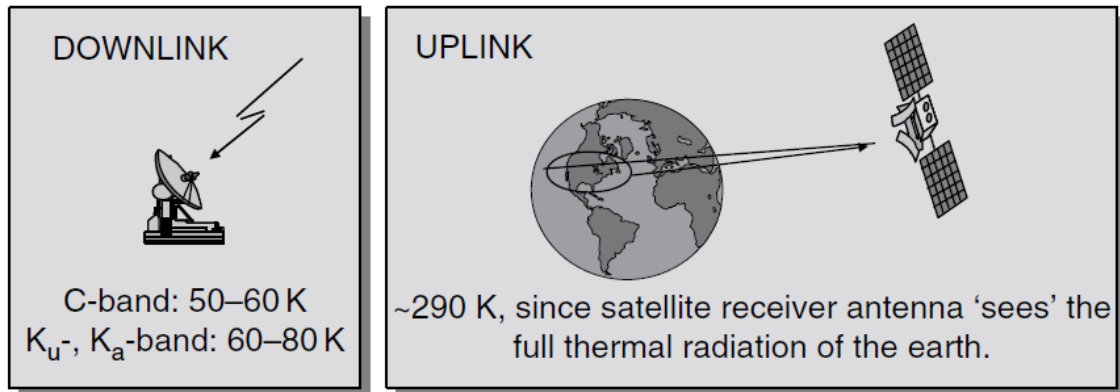

(a)

## TYPICAL ANTENNA TEMPERATURE VALUES (NO RAIN)

Rain Fade Level (dB)	1	3	10	20	30
Noise Temperature (°K)	56	135	243	267	270

(b)

## ADDITIONAL RADIO NOISE CAUSED BY RAIN



Signal processing elements  
Propagation and radio communications  
Engineering

Noise  
Link budget

## Outline

- 1 Signal processing elements
  - Signal  $\equiv$  information!
  - Source coding (dealing with the information content)
  - Modulation
  - Multiplexing
- 2 Propagation and radio communications
  - Introduction to radio communications
  - Radiowave propagation
  - Examples of antennas
- 3 Engineering
  - Noise
  - Link budget



# Example of parameter values for a communication satellite [1]

Parameter	uplink	downlink
Frequency	14.1 [GHz]	12.1 [GHz]
Bandwidth	30 [MHz]	30 [MHz]
Transmitter power	100 – 1000 [W]	20 – 200 [W]
Transmitter antenna gain	54 [dBi]	36.9 [dBi]
Receiver antenna gain	37.9 [dBi]	52.6 [dBi]
Receiver noise figure	8 [dB]	3 [dB]
Receiver antenna temperature	290 [K]	50 [K]
Free space path loss (30° elevation)	207.2 [dB]	205.8 [dB]



# Clear sky downlink performance [2]

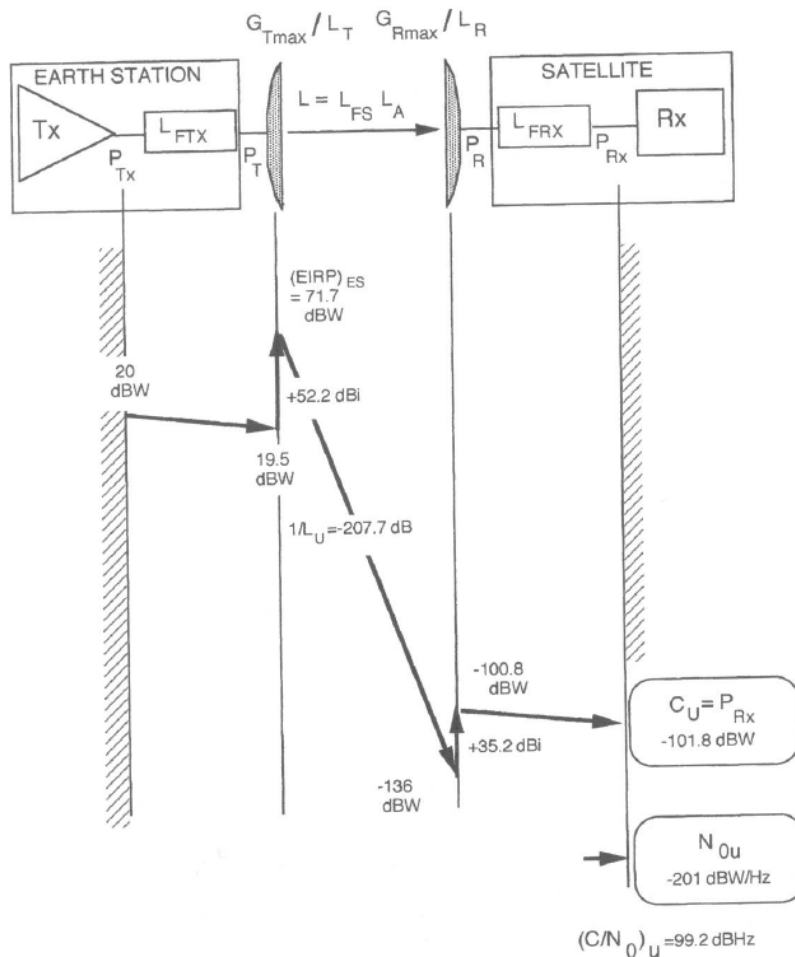

$(C/N_0)_u = 99.2$  dBHz

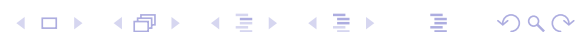



L. Ippolito.

*Satellite Communications Systems Engineering: Atmospheric Effects, Satellite Link Design and System Performance*. Wiley, 2008.



G. Maral, M. Bousquet.

*Satellite Communications Systems: Systems, Techniques and Technology*. Wiley, 2002.



J. Gibsons.

*The Communications Handbook*. CRC Press, 1997.



Wikipedia.

<http://wikipedia.org>