

Differential functionalities of amphiphilic peptide segments of the cell-septation penicillin-binding protein 3 of *Escherichia coli*

Monique Marrec-Fairley,¹ André Piette,¹ Xavier Gallet,² Robert Brasseur,² Hiroshi Hara,³ Claudine Fraipont,¹ J. M. Ghuysen¹ and M. Nguyen-Distèche¹

¹Centre d'Ingénierie des Protéines, Université de Liège, Institut de Chimie, B6, Sart Tilman, B-4000 Liège, Belgium.

²Centre de Biophysique Moléculaire Numérique, Faculté Universitaire des Sciences Agronomiques, B-5030 Gembloux, Belgium.

³Department of Biochemistry and Molecular Biology, Saitama University Faculty of Science, 255 Shimo-Ohkubo, Urawa, Saitama 338-8570, Japan.

Summary

The class B M1-V577 penicillin-binding protein (PBP) 3 of *Escherichia coli* consists of a M1-L39 membrane anchor (bearing a cytosolic tail) that is linked via a G40-S70 intervening peptide to an R71-I236 non-catalytic module (containing the conserved motifs 1-3) itself linked via motif 4 to a D237-V577 catalytic module (containing the conserved motifs 5-7 of the penicilloyl serine transferases superfamily). It has been proposed that during cell septation the peptidoglycan crosslinking activity of the acyl transferase module of PBP3 is regulated by the associated M1-I236 polypeptide itself in interaction with other components of the divisome. The fold adopted by the R71-V577 polypeptide of PBP3 has been modelled by reference to the corresponding R76-S634 polypeptide of the class B *Streptococcus pneumoniae* PBP2x. Based on these data and the results of site-directed mutagenesis of motifs 1-3 and of peptide segments of high amphiphilicity (identified from hydrophobic moment plots), the M1-I236 polypeptide of PBP3 appears to be precisely designed to work in the way proposed. The membrane anchor and the G40-S70 sequence (containing the G57-Q66 peptide segment) upstream from the non-catalytic module have the information ensuring that PBP3 undergoes proper insertion within the divisome at the cell septation site. Motif 1 and the I74-L82 overlapping peptide segment, motif 2 and the H160-G172 overlapping peptide segment, and the G188-D197 motif 3 are located at or close to the intermodule junction. They contain the information ensuring that PBP3 folds correctly and the acyl transferase catalytic centre adopts the active configuration. The E206-V217 peptide segment is exposed at the surface of the non-catalytic module. It has the information ensuring that PBP3 fulfils its cell septation activity within the fully complemented divisome.

Introduction

The bacterial cell wall peptidoglycan is a covalently closed net-like polymer in which glycan chains made of alternating β -1,4-linked *N*-acetylglucosamine and *N*-acetylmuramic acid residues are crosslinked by short peptides. In *Escherichia coli*, the carboxyl groups of the *N*-acetylmuramic acid residues are amide-linked to L-alanyl- γ -D-glutamyl-(L)-*meso*-diaminopimelyl-(L)-D-alanine peptides and the peptide crosslinkages are, mainly, direct D-alanyl-(D)-*meso*-diaminopimelic acid peptide bonds. The immediate biosynthetic precursor of the peptidoglycan is lipid II. A disaccharide pentapeptide [L-alanyl- γ -D-glutamyl-(L)-*meso*-diaminopimelyl-(L)-D-alanyl-D-alanine] is linked to a C₅₅H₈₉ undecaprenyl carrier via a pyrophosphate bridge involving C1 of *N*-acetylmuramic acid.

From this precursor, the class A multimodular penicillinbinding protein (PBP) 1a and PBP1b (Goffin and Ghuysen, 1998) catalyse the formation of polymeric peptidoglycan (Nakagawa *et al.*, 1984; van Heijenoort, 1996; Terrak *et al.*, 1999). These PBPs consist of a membrane anchor which is linked to the amino end of a catalytic glutamic acid glycosyl transferase module (which catalyses glycan chain elongation), itself linked to the amino end of a catalytic serine acyl transferase module (which catalyses peptide crosslinking). Penicillin is a suicide substrate of the acyl transferase. The reaction produces a stable serine ester-linked penicilloyl enzyme such that the inactivated enzymes behave as PBPs.

Shaping the raw peptidoglycan material made by PBP1a and PBP1b into a sacculus in a cell cycle-dependent fashion relies on the class B multimodular PBP2 and PBP3 and on a set of non-penicillin-binding proteins

(Wientjes and Nanninga, 1991). PBP2 and RodA, whose encoding genes are located at the 14 min region of the chromosome, control wall expansion and shape maintenance (Spratt, 1975; Begg *et al.*, 1990). PBP3, FtsL, FtsW, FtsQ, FtsA, FtsZ, whose encoding genes are located at the 2 min region, and FtsK, ZipA and FtsN, whose encoding genes are located at 21 min, 52 min and 88 min, respectively, form a multiprotein complex, the divisome, which encompasses the cytoplasm, the plasma membrane and the periplasm (Hale and de Boer, 1997; Nanninga, 1998; Wang and Lutkenhaus, 1998; Wang *et al.*, 1998; Weiss *et al.*, 1999). FtsZ is a GTPase related to eukaryotic tubulins (de Boer *et al.*, 1992; RayChaudhuri and Park, 1992; Lowe and Amos, 1998). FtsZ polymerizes into a ring-shaped structure at the cell division site, recruits the other cell division proteins and provides the driving force for cytokinesis (Bi and Lutkenhaus, 1990; Lutkenhaus and Addinall, 1997).

The class B PBPs have a multimodular design similar to that of the class A PBPs (Goffin and Ghuysen, 1998). However, the polypeptide upstream from the acyl transferase module is not a glycosyl transferase. The role that this module plays in the spatiotemporal control of peptidoglycan synthesis remains contentious. There is evidence that *E. coli* PBP3 performs peptidoglycan crosslinking (the acyl transferase module) and that this activity is regulated by the associated non-catalytic module itself in interaction with other components of the divisome (Adam *et al.*, 1997; Goffin and Ghuysen, 1998; Nguyen-Distèche *et al.*, 1998).

The notion that peptide segments of relatively great amphiphilicity have protein-protein interaction potentials was formulated by De Loof *et al.* (1986) in their studies on apolipoprotein E. In an attempt to identify regions of the class B PBP3 possibly involved in intra- and intermolecular interactions, the mean α -helical hydrophobic moment and the mean hydrophobicity were calculated along the amino acid sequence of the protein. The roles of amphiphilic segments detected on the basis of these hydrophobic moment plots were probed experimentally. By combining the results thus obtained and previously published data, it was possible to identify three regions of the non-catalytic module of PBP3, each performing distinct specific functions.

Results

Predictive studies: detection and spatial disposition of amphiphilic segments of E. coli PBP3

Following the normalized scale of Eisenberg, hydrophobic residues have a positive value (Ile, 1.4; Pro, 0.12) and hydrophilic residues have a negative value (Thr, -0.05; Arg, -2.5). The asymmetry of hydrophobicity of a periodic peptide structure can be represented as a two-dimensional helical wheel, whose projection down the helix shows the relative orientations of residues (Eisenberg, 1984). The hydrophobic moment, which is a quantitative measure of the amphiphilicity perpendicular to the axis, is calculated from the sum of the mean hydrophobicity values over all amino acid residues and the angles at which successive side-chains emerge from the backbone (Eisenberg *et al.*, 1982). The hydrophobic moment is small when the residues are evenly distributed along the helix. It is large when most of the hydrophobic residues occur on one side of the helix and most of the hydrophilic residues on the other side. The hydrophobic moment concept is not restricted to α -helices. β -Turns consist of four residues whose side-chains protrude outside the peptide fold and the value of the angle between two linked residues is 90°, close to the 100° angle in an α -helix. Moreover, molecular modelling of proteins assumed to adopt a complete α -helix form gives valuable information on the helix and β structures (Poupon and Mornon, 1998).

The 588-amino-acid residue PBP3 of *E. coli* is processed into mature M1-V577 PBP3 (Nagasawa *et al.*, 1989). The hydrophobic moment plot of the mature protein was calculated by moving a seven-residue window through the sequence, calculating the mean α -helical hydrophobic moment $\langle\mu\rangle$ and mean hydrophobicity $\langle H\rangle$ per segment and placing the central amino acid residue as a point on a plot $\langle\mu\rangle$ vs. $\langle H\rangle$ (Eisenberg *et al.*, 1982; De Loof *et al.*, 1986).

As shown in Fig. 1, nine peptide segments, A-I, were plotted in a region whose $\langle H\rangle$ values were equal to or less than -0.5 and $\langle\mu\rangle$ values were equal to or greater than 0.25. Individual amino acid residues affected by $\langle\mu\rangle$ values between 0.25 and 0.5 are in black on a grey background, those affected by $\langle\mu\rangle$ values larger than 0.5 are in white on a black background and the three flanking residues which fall outside the cut-off region and were used for the calculations are also identified. On the basis of the data shown in Fig. 1, segments A-I fall roughly in the following decreasing order of amphiphilicity and, presumably, of interaction potential: [E \cong F] > C > [B \cong H] > [G \cong I] > [A \cong D]. Figure 2 shows the effects of selected mutations on the hydrophobic moment plots of segments A-I. Finally, Fig. 3 shows the distribution of segments A-I along the amino acid sequence of PBP3 by reference to the conserved motifs of the non-catalytic module (motifs 1, 2 and 3), the intermodule junction site (motif 4) and the acyl transferase module (motifs 4b, 5 containing the catalytic serine 307, 6 and 7).

The 750-amino-acid residue PBP2x of *Streptococcus pneumoniae*, also of class B, has the same motifs and modular organization as PBP3 of *E. coli* except that PBP2x possesses a Pro635-Asp750 carboxy-terminal module that is not present in PBP3. The C_α co-ordinates (at 3.5 Å resolution; Pares *et al.*, 1996) of the membrane anchor-free Arg76-Asp750 polypeptide of PBP2x are available. On the basis of these data, the Arg76-Ile265 non-catalytic module of PBP2x is shaped like a pair of sugar tongs; the core, which comprises motifs 1, 2 and 3, is a cluster of peptide segments that fit in or are located close to a non-catalytic groove of the acyl transferase module. And, the two sugar tongs each possess helices exposed at the surface of the protein. In turn, the associated Ser266-Ser634 acyl transferase module has the characteristic all- α and α/β domains of the penicilloyl serine transferases superfamily. Finally, the Pro635-Asp750 carboxy-terminal module, which is PBP2x specific, consists of two small $\alpha/\beta/\beta$ domains.

Fig. 1. Hydrophobic moment $\langle\mu\rangle$ vs. hydrophobicity $\langle H\rangle$ plots of segments A-I of *E. coli* PBP3. The mutated amino acid residues (see Fig. 2) are in bold.

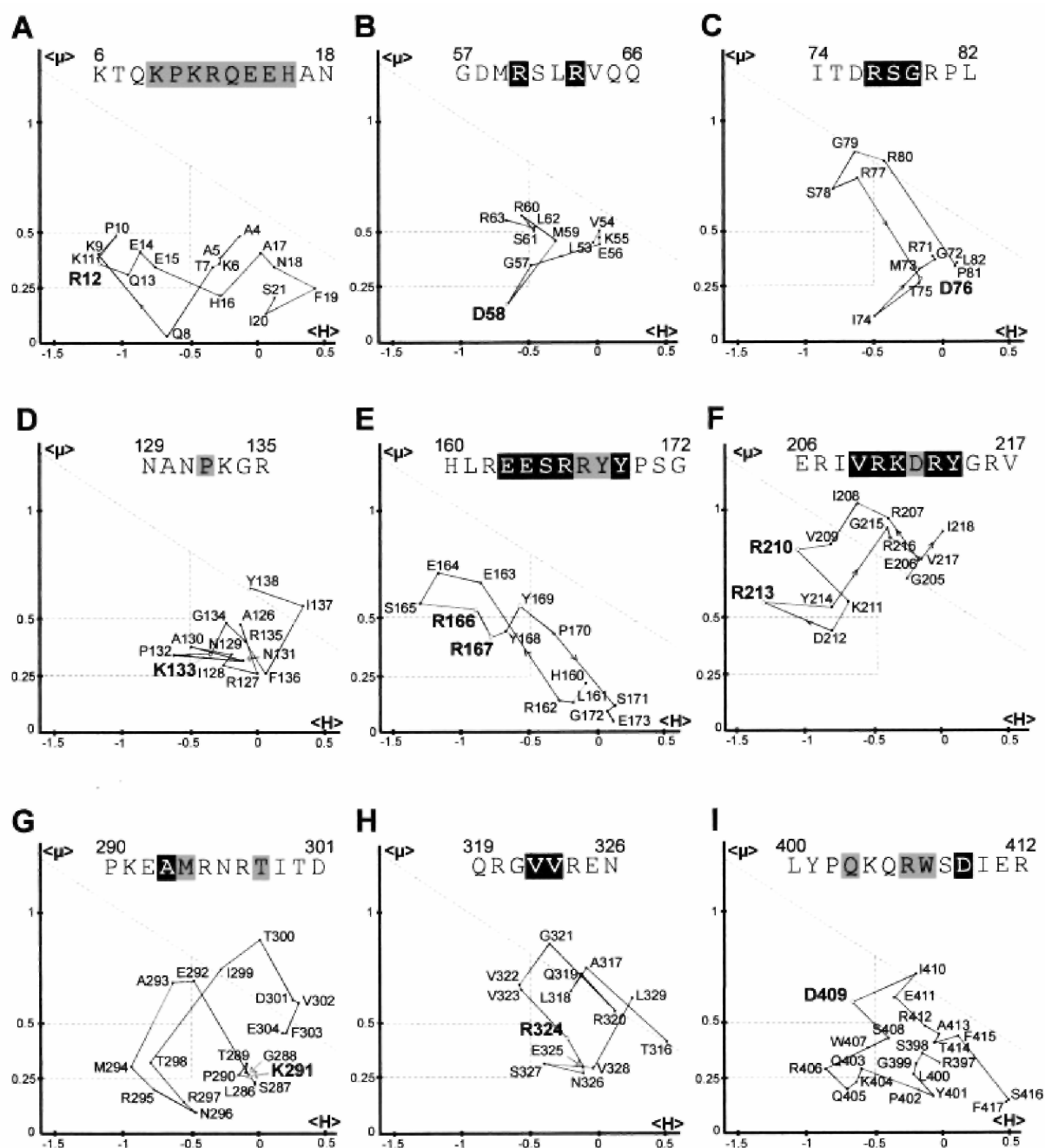

Fig. 2. Alterations of the hydrophobic moment plots of segment A caused by the R12S mutation (A), segment B caused by the D58V mutation (B), segment C caused by the DF6N mutation (C), segment D caused by the K133S mutation (D), segment E caused by the R166Q;R167Q double mutation (E), segment F caused by the R210Q;R213Q double mutation (F), segment G caused by the K291S mutation (G), segment H caused by the R234Q mutation (H) and segment I caused by the D409A mutation (I).

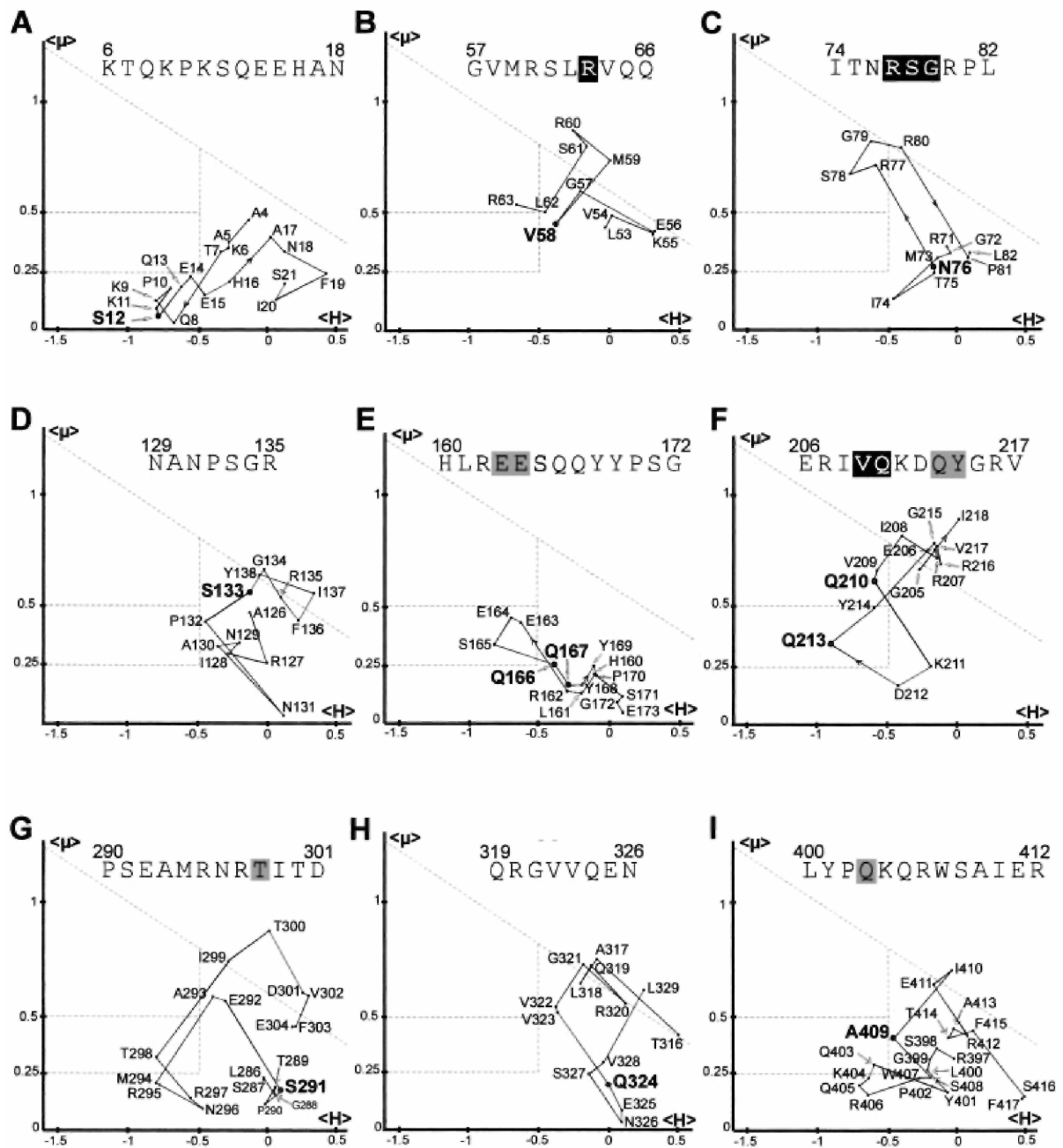

Fig. 3. Amino acid sequence analysis of *E. coli* PBP3. Conserved motifs 1-7 and segments A-l are shown. Hatched area, plasma membrane; x, variable amino acid residue. The amino acid residues shown in black on a grey background are characterized by a hydrophobic moment ranging between 0.25 and 0.5. The amino acid residues shown in white on a black background are characterized by a hydrophobic moment >0.5.

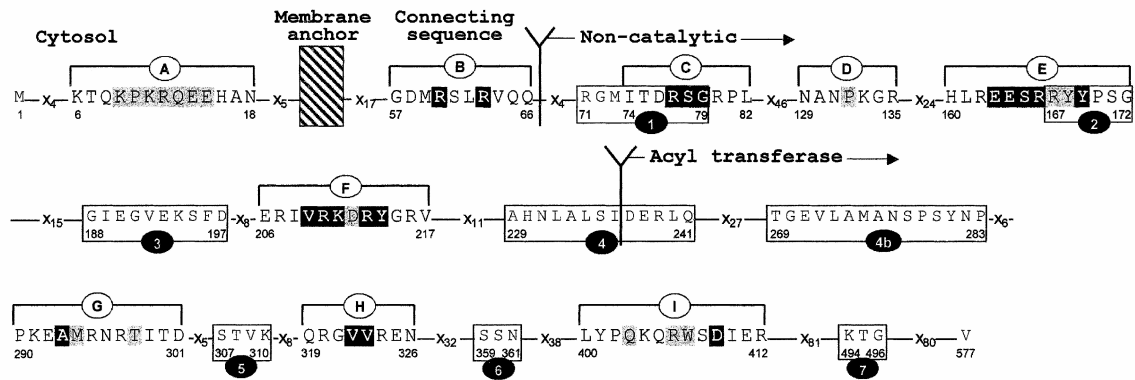

Fig. 4. Spatial disposition of motifs 1, 2 and 3 and segments A-l along the polypeptide chain of *E. coli* PBP3. The peptide segment of unknown structure that connects the membrane anchor and the non-catalytic module is represented as a dotted grey line. The non-catalytic module is in red. The acyl transferase module is in yellow. Amphiphilic segments are identified by the amino acid residues (in CPK; Koltun, 1965) falling within the region $\langle H \rangle < -0.5$; $\langle \mu \rangle > 0.25$ of the hydrophobic moment plots. Motif 1 is in green. Motifs 2 and 3 are in blue. Motif 4 (not shown) overlaps the junction between the non-catalytic (red) and acyl transferase (yellow) modules. The structure was modelled as described in the Experimental procedures.

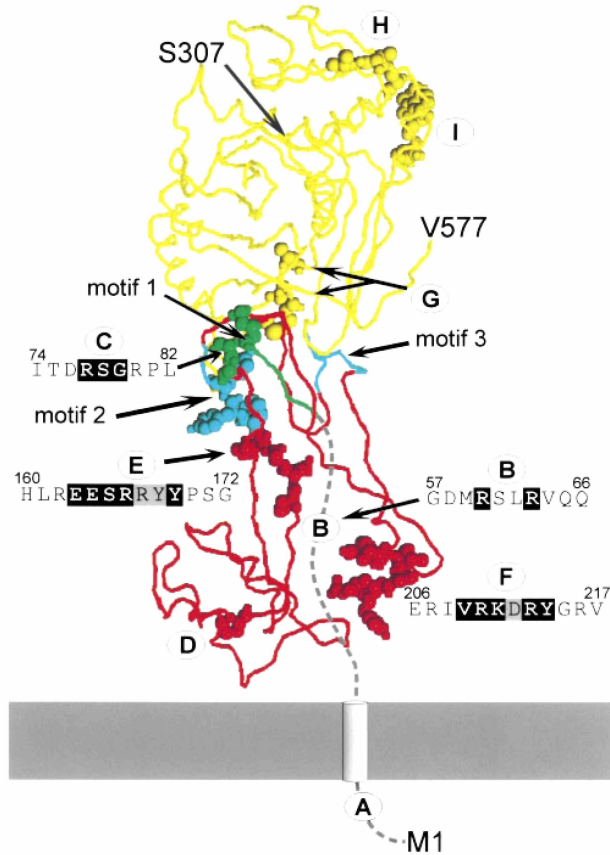

Table 1. Structural requirements for *E. coli* PBP3 activities.

PBP3 variant	Membrane anchor	Segment: Motif:	Non-catalytic							Acyl transferase	Cell septation activity	Penicillin binding	Toxic effect
			B	C	E	F	3	4	4				
Wild type	M1		G57D58	D76	R166R167	E193	R210R213		S307	S588	+	+	
1 ^a	M1							R239			-	-	+
2	M1								A or C307	S588	-	-	+
3	M1		V58						A307	S588	-	-	-
4	M1		V58						S307	S588	-	+	-
5	M1				Q166Q167				S307	S588	-	-	-
6	M1						Q210Q213		S307	S588	-	+	+
7	M1		V58				Q210Q213		S307	S588	-	ND	-
8 ^b	LppSpG41								A307	S588	-	-	-
9 ^b	LppSpG41								S307	S588	-	+	-
10 ^c			G57						S307	S588	-	+	-
11 ^d	M1			N76		E193D			S307	S588	+	+	-
12 ^e	M1					E193Q			S307	S588	-	+	-

a. Variant 1 contains an eight-amino-acid residue extension downstream from R239. See *Materials and Methods*.

b. LppSp, lipoprotein signal peptide. For more details on variants 7 and 8, see Houba-Hérin *et al.* (1985).

c. Variant 9 lacks the M1-E56 peptide segment of the native PBP (Fraipont *et al.*, 1994).

d. Variant 10 has decreased thermostability (Goffin *et al.*, 1996).

e. The E193-D variant can be detected in very small amounts, whereas the E193-Q variant is not detectable by fluorography and immunoblotting (Goffin *et al.*, 1996).

ND, not determined.

The Arg71 -Val577 polypeptide of *E. coli* PBP3 and the corresponding Arg76-Ser634 polypeptide of *S. pneumoniae* PBP2x share about 22% identities in the amino acid sequences. The fold adopted by the Arg71-Val577 polypeptide of *E. coli* PBP3 was modelled (see *Experimental procedures*). Although the structure shown in Fig. 4 remains short of reality, several observations can be safely made. Segment A is in the cytosol; it has low amphiphilicity. Segment B is located in the peptide that connects the membrane anchor to the non-catalytic module; it has moderate amphiphilicity. Segments C and E are within the core, and segment F is on one sugar tong of the non-catalytic module; they each have strong amphiphilicity. Segment D, on the other sugar tong, has weak amphiphilicity. Segments G-I are located within the acyltransferase module; they have low amphiphilicity except segment H, whose amphiphilicity is moderate.

Based on published data and the results of site-directed mutagenesis experiments described below, several regions of PBP3 endowed with different functionalities were identified.

The K6-N18 segment A and G57-Q66 segment B

PBP3 occurs in a small copy number, about 50-100 per cell, and its overproduction to a few thousands is harmless. The acyl transferase moduleless M1-R239 polypeptide of PBP3 (variant 1 in Table 1) and, likewise, the full-size PBP3 mutants in which an alanine or cysteine residue substitutes for the catalytic serine 307 (variant 2 in Table 1; Broome-Smith *et al.*, 1985; Houba-Hérin *et al.*, 1985) each lack penicillin-binding and cell septation activities, as expected, and they each are toxic. *E. coli* strains co-producing the wild-type PBP3 and the truncated M1-R239 PBP3 or the wild-type PBP3 and the full-size Ser307Ala or Ser307Cys PBP3 mutant grew as filaments. This toxic phenotype indicates that these variants each compete with the resident native PBP3 of the *E. coli* transformants in which they are overproduced and prevent it from being functional.

The substitution of Val for Asp58 of segment B of the Ser307Ala PBP3 mutant gave rise to a Asp58Val; Ser307Ala double mutant (variant 3 in Table 1), which was no longer toxic. In turn, the substitution of Val for Asp58 of segment B of the wild-type PBP3 gave rise to a Asp58Val single mutant (variant 4 in Table 1), which bound penicillin but lacked complementation activity in an *E. coli ftsI* null mutant. This was examined by introducing a plasmid carrying the modified *ftsI* gene into the *ftsI*-deletion JE7947 strain harbouring plasmid pHR295 in which the wild-type *ftsI* was under the control of the *lac* promoter. At 37°C and in Luria-Bertani medium containing 10 mM glucose and appropriate antibiotics, the transformant was completely dependent on the presence of 0.5 mM isopropyl-β-D-thiogalactopyranoside (IPTG) for growth. Hence, Asp58 of segment B was important for the *in vivo* functionality of the wild-type PBP3 and the substitution of Val for Asp58 abolished the toxic effect of the S307A mutation. One may note that segment B had two amino acid residues, Arg60 and

Arg63, whose $\langle\mu\rangle$ values were greater than 0.5 (Fig. 1 B). Substitution of Val for Asp58 (Fig. 2B) caused a displacement of the hydrophobic moment plot towards a greater hydrophobic moment but also a greater hydrophobicity so that one single residue, Arg63, had a $\langle\mu\rangle$ value greater than 0.5.

Segment A (K6-N18) has low amphiphilicity (Fig. 1A) and, presumably, low interaction potential. The hydrophobic moment plot of the mutated segment A in which Ser substitutes for Arg12 falls outside the cut-off region (Fig. 2A). The R12S mutation did not affect the *in vivo* functionality of PBP3 (as examined in the *ftsI* null *E. coli* strain EC548).

The H160-G172 segment E and overlapping R167-G172 motif 2

These sequences fall within the core of the non-catalytic module. Arg166 and Arg167 of segment E (HLREESR166R167YYPSG) were changed into Gln (variant 5 in Table 1), resulting in a much decreased amphiphilicity of the segment (Figs 1E and 2E). *E. coli* RP41 and *E. coli* SP1097, which each produce a thermosensitive (42°C) PBP3, were used as hosts to produce the wild-type PBP3 and the R166Q;R167Q PBP mutant from properly engineered pUCBM20/*ftsI* vectors (see *Experimental procedures*). The transformants harbouring the gene encoding the wild-type PBP3 grew as rods at 30°C and at 42°C in Luria-Bertani (LB) medium supplemented with 50 $\mu\text{g ml}^{-1}$ ampicillin. The transformants harbouring the gene encoding the R166Q;R167Q PBP3 mutant grew as rods at an unchanged rate at 30°C. At 42°C, they grew as filaments for about 2 h (Fig. 5A). Hence, decreasing the amphiphilicity of segment E yielded a protein mutant which was no longer functional *in vivo*.

E. coli LMG194/pLD139 transformants were then constructed in which the genes encoding the wild-type PBP3 and the R166Q;R167Q PBP mutant were under the control of the P_{BAD} arabinose promoter (see *Experimental procedures*; Guzman *et al.*, 1997), thus allowing the desired proteins to be overproduced in a controlled manner. The transformants each grew at a normal rate and with a normal morphology at 37°C in LB medium containing 0.2% glucose and 50 $\mu\text{g ml}^{-1}$ kanamycin. When the cultures reached an optical density of 0.8 at 600 nm, the cells were collected and then cultured in LB medium containing 0.2% arabinose for 1 h at 37°C. The transformants overproducing the wild-type PBP3 and those overproducing the R166Q;R167Q protein mutant grew normally. Occasionally, transformants producing the protein mutant occurred in the form of small chains. Hence, the overproduction of the R166Q;R167Q protein mutant did not prevent the resident native PBP3 from being functional.

To translate these observations into biochemical terms, the transformants grown in the presence of arabinose for 1 h at 37°C were spheroplasted and the isolated plasma membranes were analysed by Western blot with polyclonal anti-PBP3 antibodies. The R166Q;R167Q protein mutant was overproduced in similar amounts to the wild-type PBP3 (Fig. 6A), showing that this double mutation did not cause proteolytic susceptibility. The membrane-bound R166Q;R167Q protein mutant was then examined with respect to its ability to bind [³H]-benzylpenicillin. It failed to bind penicillin (Fig. 6B).

The N129-R135 segment D and N206-V217 segment F

Segment F is located at the surface of one sugar tong of the non-catalytic module. It has strong amphiphilicity (Fig. 1F). Arg210 and Arg213 of segment F (ERIVR210K-DR213YGRV) were changed into Gln (variant 6 in Table 1), causing a much decreased amphiphilicity (Fig. 2F). *E. coli* SP1097 and RP41 were used as hosts to produce the R210Q;R213Q PBP mutant, as described above for the R166Q;R167Q PBP mutant. The transformants harbouring the gene encoding the R210Q;R213Q PBP3 mutant grew at 30°C at a reduced rate as a mixture of rods and filaments. At 42°C, they stopped growing and they underwent conversion into long autolysing filaments (Fig. 5B).

E. coli LMG194/pLD139 transformants overproducing the R210Q;R213Q PBP mutant under the control of the P_{BAD} arabinose promoter grew at a normal rate with normal morphology at 37°C in LB medium containing 0.2% glucose. Upon transfer of the cells into LB medium containing 0.2% arabinose, the transformant stopped growing and the cells underwent conversion into long filaments, indicating that the R210Q;R213Q protein mutant prevented the resident wild-type PBP3 from being functional.

As derived from Western blot analysis of the plasma membranes isolated from transformants grown in the presence of 0.2% arabinose for 1 h at 37°C, the R210Q;R213Q protein mutant was produced in amounts nearly similar to that obtained with the wild-type PBP3 (Fig. 6A). The protein mutant bound penicillin (Fig. 6B), and its thermostability and affinity for penicillin were similar to those of the wild-type PBP3 (second-order rate constant

of penicilloylation $500 \text{ M}^{-1}\text{s}^{-1}$ at 30°C).

The substitution of Val for Asp58 in segment B of the R210Q;R213Q PBP3 mutant gave rise to a PBP3 mutant (variant 7 in Table 1) which was no longer toxic. This was analysed after transformation of *E. coli* XL1 blue with the proper pUCBM20/*fsl* recombinants (see *Experimental procedures*). At 37°C , in LB medium, the transformants producing the double R210Q;R213Q PBP3 mutant grew as a mixture of rods and filaments, whereas the transformants producing the triple D58V;R210Q;R213Q PBP3 mutant grew as rods.

Segment D is located at the surface of the other sugar tong of the non-catalytic module of PBP3. At variance with segment F, segment D has low amphiphilicity (Fig. 1D) and, presumably, low interaction potential. The Lys133-Ser mutation did not affect the *in vivo* functionality of PBP3, although the hydrophobic moment plot of the mutated Lys133Ser segment D fell outside the cut-off region (Fig. 2D).

The P290-D301 segment G, Q319-N326 segment H and L400-R412 segment I

Segment G, H and I are located within the acyl transferase module. The K291S mutation of segment G, the Arg324Gln mutation of segment H and the Asp409Ala mutation of segment I resulted in a displacement of the hydrophobic moment plot outside the cut-off region (Figs 1G-I and 2G-I). The mutations Lys291Ser and Arg324Gln did not affect the *in vivo* activity of PBP3 (as measured in *fsl* null *E. coli* strain EC548). Likewise, and as shown by Goffin *et al.* (1993), the mutation Asp409Ala was neutral.

Fig. 5. Complementation activities of (pUCBM20/*fsl*) plasmids encoding the wild-type PBP3 (WT), the R166Q;R167Q mutant (A) and the R210Q;R213Q;PBP3 mutant (B). The strain SP1097 was used as host (see *Experimental procedures*). The cells were observed under phase-contrast microscopy.

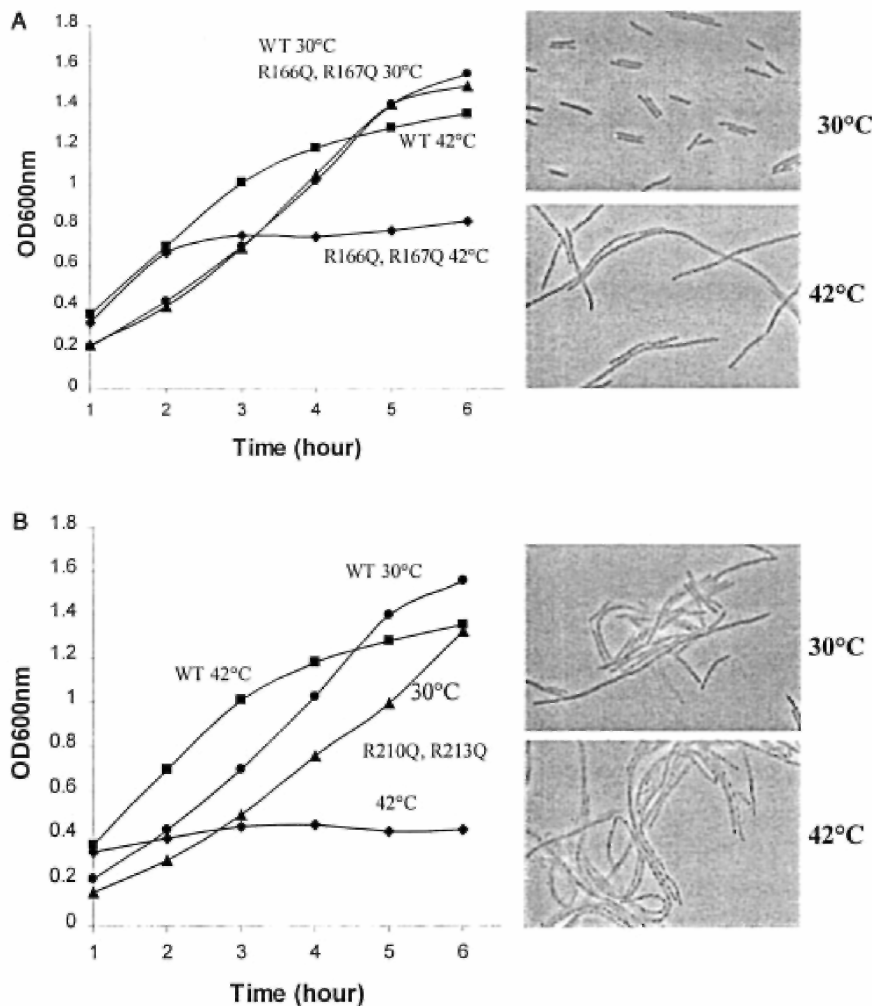
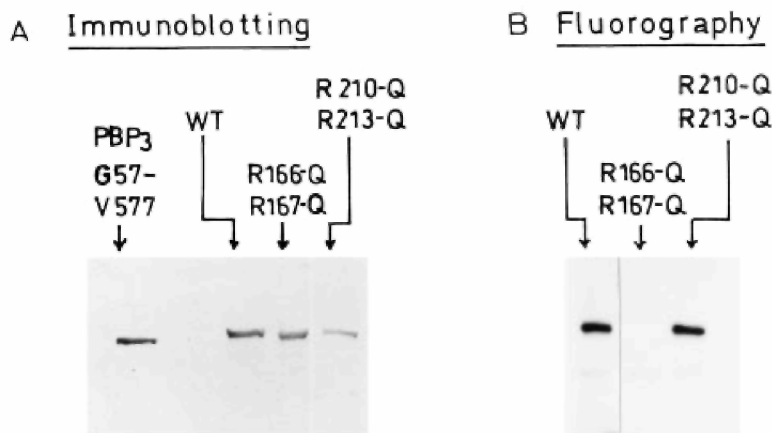

Fig. 6. SDS-PAGE analysis of the purified G57-V577 PBP3, the membrane-bound wild-type PBP3 (WT) and the R166Q;R167Q and R210Q;R213Q PBP mutants isolated from *E. coli* LMG194/pLD139 transformants. The samples were labelled with 100 μ M [3 H]-benzylpenicillin before fluorography. Polyclonal antibodies directed against PBP3 were used for immunoblotting.



Discussion

The divisome encompasses the cytosol, the plasma membrane and the periplasm and its global function is to build the septum at mid-cell during cell division. The M1-V577 class B PBP3 of *E. coli* is an essential component of the divisome. It was proposed that the peptidoglycan crosslinking activity of the D237-V577 acyl transferase module of PBP3 might be regulated by the associated amino terminal polypeptide itself in interaction with other components of the morphogenetic complex. The main result of the experiments presented above is that the M1-I236 polypeptide chain of PBP3 is precisely designed to work in the way that was suggested. Three regions of this polypeptide are endowed with distinct specific functionalities.

Segment B is located on the peptide chain that links the transmembrane anchor and the non-catalytic module. Substitution of Val for Asp58 of segment B gives rise to a PBP3 mutant (variant 4 in Table 1) which binds penicillin but is not functional, and the same substitution abolishes the toxic effect of the S307A mutation (variant 3 in Table 1). Segment B, however, is not the only structural determinant involved in this detoxication process. The toxic effect of the S307A mutation can also be abolished by substituting the uncleavable lipoprotein signal peptide for the genuine M1-G40 sequence of the S307A PBP3 mutant (variant 8 in Table 1) (Houba-Herlin *et al.*, 1985). Moreover, the PBP3 mutant obtained by substituting the Lpp signal peptide for the M1-G40 segment of the wild-type PBP3 (variant 9 in Table 1) (Houba-Herlin *et al.*, 1985) and the OmpA signal peptide-transported, membrane anchor-less and water-soluble G57-V577 polypeptide chain (variant 10 in Table 1) (Fraipont *et al.*, 1994; Goffin *et al.*, 1996) each bind penicillin, lack cell septation activity and can be overproduced without causing detectable toxic effects. Hence, elimination of the membrane anchor of PBP3 and proper alteration of segment B (the D58V mutation) each prevent the corresponding, non-functional protein variants from competing with the wild-type PBP.

A straightforward interpretation of these results is that the F24-Q66 sequence, which comprises the membrane anchor and segment B, plays an important role in the proper orientation and positioning of PBP3 during its insertion within the divisome at the cell septation site. In previous studies, the F24-G40 transmembrane segment was identified as an essential determinant for the cell septation activity and proper localization of PBP3 (Weiss *et al.*, 1999), and the M1-D56 sequence was shown not to be required for proper folding of the acyl transferase module (Goffin *et al.*, 1996). One may note that the role that the cytosolic tail M1-R23 and segment A may play in PBP localization remains uncertain (Weiss *et al.*, 1999).

The R71-G75 motif 1 and overlapping I74-L82 segment C, the R167-G172 motif 2 and overlapping H160-G172 segment E and the G188-D195 motif 3 each fall within the core of the non-catalytic module of PBP3, at the intermodule junction. Altering the H160-G172 segment E (and overlapping motif 2) in a way that decreases the amphiphilicity of the segment gives rise to a R166Q;R167Q protein mutant (variant 5 in Table 1) which lacks cell division activity, lacks penicillin-binding capacity and lacks toxicity, i.e. to a protein mutant whose F24-Q66 peptide segment is no longer capable of targeting the PBP within the divisome and D237-S588 acyl transferase

module is no longer capable of binding penicillin. Hence, segment E and the overlapping motif 2 play an important role in module-module interaction and/or contain an essential folding information for the entire polypeptide chain. Similar roles were previously attributed to the I74-L82 segment C and overlapping motif 1 and the G188-D197 motif 3. As shown by Goffin *et al.* (1996), substituting Asn for Asp⁷⁶ of segment C (variant 11 in Table 1) yielded a protein mutant which bound penicillin and had cell septation activity. This mutation did not modify the hydrophobic moment plot of the segment (Fig. 2C). Yet, the D76N PBP3 mutant had a decreased thermostability. In turn, substituting Asp or Asn for Glu¹⁹³ of motif 3 yielded protein mutants (variants 12 in Table 1) that were so unstable that they could not be isolated from the producing transformants (Goffin *et al.*, 1996).

A straightforward interpretation of these results is that segment C and overlapping motif 1, segment E and overlapping motif 2 and motif 3 form, within the core of the non-catalytic module of PBP3, an integrated structure-folding information ensuring that PBP3 acquires its proper conformation for cell septation activity.

The E206-V217 segment F is located at the surface of one of the sugar tongs of the non-catalytic module of PBP3. Altering segment F in a way that decreases the amphiphilicity gives rise to a R210Q;R213Q PBP3 mutant which has the same *in vitro* activities as the wild-type PBP3 (variant 6 in Table 1). However, it lacks cell division activity and, in addition, it has the same toxic phenotype as the S307C and S307A protein mutants. This toxic phenotype indicates that the F24-Q66 peptide segment still targets the R210Q;R213Q PBP mutant to the divisome. Consistently, the D58V mutation in segment B abolishes the toxicity of the R210Q;R213Q double mutation. Hence, segment F is not involved in the folding of PBP3 nor in its positioning within the divisome. Rather, segment F plays a key role in the functioning of the PBP within the fully complemented divisome, presumably by providing an essential site for interaction with other components of the cellular machine. The partner(s) possibly involved in these interactions remain(s) unknown. FtsW (an integral membrane protein), FtsL, FtsN, FtsQ, PBP1a and/or PBP1b are plausible candidates.

The results of the experiments presented above also deserve additional comments: Segments B, C, E and F of the non-catalytic module of the *E. coli* PBP3 are involved, one way or another, in intra-and/or interprotein interactions. They are regions of the protein in which the hydrophobic residues align mainly at one side of the structure, either α or β , and, at the same time, show a low hydrophobicity. Their mean hydrophobicities are smaller than -0.5 and they contain two (segment B), three (segment C) and five (segments E and F) amino acid residues whose mean hydrophobic moments are greater than 0.5. In contrast, segment A in the cytosol, segment D of the non-catalytic module and segments G-I of the acyl transferase module of PBP3 are functionally non-important. Their mean hydrophobicities are also smaller than -0.5. Segments A and D have no amino acid residues and segments G and I have only one amino acid residue whose mean hydrophobic moment is greater than 0.5. Segment H, however, has two amino acid residues whose mean hydrophobic moments are greater than 0.5. Amphiphilicity is not the sole parameter governing protein-protein interaction; shape and accessibility are also involved. Moreover, the $\langle\mu\rangle$ vs. $\langle H\rangle$ predictive method does not take into account possible hydrophobic interactions.

E. coli PBP3 has no transglycosylase activity (Adam *et al.*, 1997). One has to assume that during synthesis of the septal peptidoglycan, PBP3 works in conjunction with one class A PBP, PBP1a or PBP1b or both. The class A PBP(s) would manufacture and, to some extent, crosslink peptidoglycan primers that would be used by the acyl transferase module of PBP3. Inactivation of the cytoskeletal FtsZ in *E. coli* is associated with a significant change in the length distribution of glycan strands in newly synthesized peptidoglycan, with a shift from long to short chain lengths, indicating a link between FtsZ and at least one class A PBP (Ishidate *et al.*, 1998). One may also note that the class A PBP1 of *Bacillus subtilis*, which is an orthologue of PBP1 a or PBP1 b of *E. coli*, localizes at the division site and is a component of the divisome in this organism (Pedersen *et al.*, 1999).

The class B PBPs are endowed with multiple functionalities: in *E. coli*, PBP2, a paralogue of PBP3, is involved in wall expansion and cell shape maintenance. Motif 1 and overlapping segment C, motif 2, and motif 3 and overlapping segment E of PBP3 are conserved features of the class B PBPs, suggesting that these structural features have similar functional properties in all class B PBPs, irrespective of the roles that these PBPs play in cell morphogenesis. In contrast, the membrane anchor, segment B and segment F of PBP3 are not associated with conserved motifs, suggesting that they are specific to PBP3 and, by extension, to other cell septation class B PBPs.

Experimental procedures

Bacterial strains, vectors and growth media

The bacterial strains and vectors used in this study are *E. coli* K12 derivatives. They are listed in Table 2. The bacteria were grown in Luria-Bertani (LB) medium supplemented with ampicillin ($100 \mu\text{g ml}^{-1}$) or kanamycin ($50 \mu\text{g ml}^{-1}$ for multicopy plasmids; $20 \mu\text{g ml}^{-1}$ for a mini-F plasmid), chloramphenicol ($10 \mu\text{g ml}^{-1}$) and/or IPTG (0.5 mM), when appropriate.

Constructions of PBP3 variants

The *ftsI* gene cloned in the pUCBM20 vector in the opposite direction to the *lac* promoter (Goffin *et al.*, 1996) was used as a template for mutagenesis using the Quick Change Site-directed Mutagenesis kit from Stratagene. The following oligonucleotides were used: 5'-CGCAGAAACCAAATCCCCAGGAAGAACATGCC-3' and its complementary strand (R12S mutation); 5'-TAACGCCAACCCGTCCGGGCGCTTTATTTATCTGG-3' and 5'-AATAAAGCGCCCGGACCGGGTTGGCGTTAATGC-3' (K133S mutation); 5'-ATC-TGCGTGAAGAGTCTCAACAATACTATCCGTCCGG-3' and its complementary strand (double mutation R166Q;R167Q); 5'-GAGCGCATTGTGCAAAAAGACCAATATGGT-CGCGT-AA-3' and its complementary strand (double mutation R210Q;R213Q); 5'-CTGAGCGGCACGCCGTCCGAGGCGATGCGTAACC-3' and its complementary strand (K291S mutation); 5'-CGTGGCGTGGTGCAGGAAAACTEGG-3' and its complementary strand (R234Q mutation); 5'-GGTGAAGAGGGCGTCATGCGTTCTCTTCGCG-3' and its complementary strand (triple mutation D58V;R210Q; R213Q). After mutagenesis, plasmids were prepared from randomly picked transformants. The mutated clones were identified by sequencing the *ftsI* genes. The *NcoI*-*SacII* fragment containing the R12S mutation was excised from pUCBM20/*ftsI* recombinants and inserted into the corresponding sites of pUCBM20/*ftsI*. The *SacII*-*PstI* fragment containing the K133S mutation was isolated from the pUCBM20/*ftsI* recombinant and inserted into the sites of pUCBM20/*ftsI*. The *PstI*-*EcoRI* fragment containing the K291S or R324Q mutation was excised from the pUCBM20/*ftsI* recombinant and introduced between the corresponding sites of pUCBM20/*ftsI*. The *SacII*-*PstI* or *SacII*-*KpnI* fragments containing double mutations were then excised from pUCBM20/*ftsI* recombinants and inserted into the *SacII*-*PstI* sites of pUCBM20/*ftsI* or *SacII*-*KpnI* site of pLD139, a plasmid carrying *ftsI* gene under the control of the arabinose promoter (Guzman *et al.*, 1997). The pUCBM20/*ftsI* recombinants were used for complementation assays, the pLD139 recombinants for protein overproduction and analysis.

Mutant D58V;S307A (variant 3 in Table 1) and mutant D58V (variant 4 in Table 1) were isolated as follows: (i) the N-terminal module of PBP3 was mutagenized in a *mutD* mutator strain KD1067 and then combined with the S307A acyl transferase module under the *lac* promoter of pUC19; (ii) the mutation that reversed the dominant lethal effect of the S307A mutation in the presence of 0.5 mM IPTG was selected, and the D58V mutation was found among such intragenic suppressors (variant 3 in Table 1); (iii) the N-terminal module containing D58V was then combined with the wild-type acyl transferase module on pGB2 vector (variant 4 in Table 1).

Variant 1 (Table 1) was constructed by cleaving the *ftsI* gene on pIN-II-B2 vector with *PstI*, filled with T4 DNA polymerase and religated. The resultant *ftsI* gene codes for a polypeptide M1-R239, followed by eight residues of unnatural sequence.

Molecular biological procedures

Standard techniques were used for cloning, DNA analysis, PCR and transformation (Sambrook *et al.*, 1989).

Overproduction of the PBP3 derivatives

E. coli LMG194 harbouring pBAD18, pLD139 or pLD139 derivatives carrying various *ftsI* mutants were grown at 37°C in LB medium containing $50 \mu\text{g ml}^{-1}$ kanamycin and 0.2% D-glucose to an optical density of 0.8 at 600 nm. To induce the production of PBP3 derivatives, the culture (5 ml) was centrifuged at $3000 g$ for 10 min and the cells were suspended into 10 ml of LB/kanamycin medium supplemented with 0.2% of L-arabinose. The growth was maintained for an additional hour at 37°C . The cells were spheroplasted (Fraipont *et al.*, 1994) and the isolated membranes were stored at -20°C in 10 mM tris-HCl, pH 8, 10% glycerol.

Table 2. Bacterial strains and plasmids.

Strains or plasmids	Relevant genetic marker(s) or feature(s)	Reference
Strains		
LMG194	$\Delta ara714$	Guzman <i>et al.</i> (1995)
SP1097	<i>ftsI</i> ^{r7} (Ts)	Taschner <i>et al.</i> (1988)
RP41	<i>ftsI</i> 2158(Ts)	del Portillo and de Pedro (1990)
KD1067	<i>mutD</i>	Degnen and Cox (1974)
JE7947	$\Delta ftsI::cat\ recA1$	Hara <i>et al.</i> (1997)
JE7611	<i>ftsI</i> (Ts) <i>recA1</i>	Houba-Hérin <i>et al.</i> (1985)
EC548	$\Delta lacX74\ galE\ galK\ thi\ rpsL\ \Delta phoA\ PvuII\ ftsI::Tn\ phoAI173\ \Delta IS50R$ (Kan ^r)/pDSW262	Weiss <i>et al.</i> (1999)
Plasmids		
pUCBM20/ <i>ftsI</i>	Amp ^r	Goffin <i>et al.</i> (1996)
pBAD18-Kan	Arabinose P _{BAD} promoter, Kan ^r	Guzman <i>et al.</i> (1995)
pLD139	<i>ftsI</i> under the control of arabinose PBAD promoter	Guzman <i>et al.</i> (1997)
pGB2	Spc ^r , pSC101 replicon	Churchward <i>et al.</i> (1984)
PINII-B2	P _{LPP} -P _{LAC} , Amp ^r	Masui <i>et al.</i> (1983)
pHR295	<i>lacI</i> ^q <i>ftsI</i> under the control of P <i>lac</i> promoter operator, Kan ^r , F replicon	Hara <i>et al.</i> (1997)

Complementation assay

The pUCBM20/*ftsI* recombinants (producing variants 5 and 6) and the control plasmids were used to transform the thermosensitive PBP3-producing *E. coli* RP41 or SP1097. Transformants selected for ampicillin resistance at 30°C (Goffin *et al.*, 1996) were grown at 30°C or 42°C in liquid LB medium supplemented with 50 µg ml⁻¹ ampicillin.

The *in vivo* activity of R12S, K133S, K291S and R234Q PBP3 mutants was tested in strain EC548 that has a transposon insertion in the chromosomal *ftsI* gene and a wild-type copy under the control of the arabinose promoter in plasmid pDSW262 (Weiss *et al.*, 1999). The complementation was made in liquid LB medium containing 0.2% glucose, kanamycin, chloramphenicol and ampicillin at 37°C.

Cell septation activity of the D58V mutant (variant 4 in Table 1) was examined by introducing the plasmid into an *ftsI* deletion strain JE7947 that carries wild-type *ftsI* under the control of the lactose promoter on plasmid pHR295. The M1-R239 truncated PBP3 (variant 1) was produced into an *ftsI* (Ts) strain JE7611 harbouring F' *lacI*^q and examined for *in vivo* activity at 42°C.

Penicillin binding, thermostability and Western blotting

The level of production of the wild-type PBP3 and (R210;R213Q) PBP3 mutant was estimated by sodium dodecyl sulphate-polyacrylamide gel electrophoresis (SDS-PAGE) of membrane samples labelled with 10⁻⁴ M [³H]-benzylpenicillin (18 Ci mmol⁻¹; Radiochemical Centre, Amersham, UK) and then by Coomassie blue staining and fluorography of the gels (Fraipont *et al.*, 1994). The values of the second-order rate constant *k*₂/*K* of penicilloylation were determined as described previously (Adam *et al.*, 1997). The thermostability of PBP3 mutant was analysed by maintaining the membranes for 10 min at various temperatures from 30°C to 52°C. The amount of PBP3 left in active form was estimated by [³H]-benzylpenicillin labelling at 30°C, as measured after SDS-PAGE and fluorography. The level of production of the R166Q;R167Q PBP3 mutant was estimated by immunoblot after SDS-PAGE. Immunodetection was performed with polyclonal antibodies directed against PBP3 according to the protocol of Bio-Rad. The antigen-antibody complexes were detected with alkaline phosphatase coupled to goat anti-rabbit IgG.

Prediction of interaction sites

Interaction sites were predicted on the basis of plots of mean hydrophobic moment <μ> vs. mean hydrophobicity <H>, constructed according to the algorithm of Eisenberg *et al.* (1982). These values were calculated with a seven-residue window and a gyration angle of 100° (i.e. the angle spacing two consecutive residues observed in

the direction of the helix axis), corresponding to an α -helix conformation. The consensus hydrophobicity scale (Eisenberg, 1984) was used for the calculations.

Structure of S. pneumoniae PBP2x and E. coli PBP3

The PDB file of PBP2x protein structure (PDB 1 pmd file) contains only the C α co-ordinates (from Arg76 to Asp750). A model including all atoms of the protein was calculated using the MODELLER 4 program (Sali and Blundell, 1993) and the C α atom co-ordinates. This software uses homology modelling to predict three-dimensional structure by satisfaction of spatial restraints. The calculated structure had only 53% of the (Φ , Ψ) angle pairs in most favoured and additional allowed regions of the Ramachandran map, as plotted with PROCHECK (Laskowski *et al.*, 1993). The P-SEA program (Labesse *et al.*, 1997) was used to predict secondary structures from the C α co-ordinates. These data were introduced as constraints in a new computation with MODELLER. The final model contained 74% of (Φ , Ψ) angle pairs in most favoured and additional allowed regions of the Ramachandran plot. The root mean square deviation (RMSd) between the C α atoms of the PDB file and those of the calculated structure by MODELLER was 1.6 Å. This supports that the calculated model of PBP2x is very similar to the crystal structure. Comparison of this model of PBP2x with a model of PBP2x that was computed using the MAX SPROUT program (Holm and Sander, 1991, 1992; www2.ebi.ac.uk/dali/maxsprout) provides a RMSd value of 1.2 Å, taking into account the atoms of both backbones.

From MODELLER 4, the computed structure of PBP2x (from Arg76 to Ser634) was used as template to predict a three-dimensional model of PBP3 (from Arg71 to Val577). The PBP3 and PBP2x sequences were aligned with CLUSTALW (Higgins and Sharp, 1988). The calculated structure of PBP3 had 82% of its (Φ , Ψ) angle pairs in most favoured and additional allowed regions of the Ramachandran map, as plotted with PROCHECK. The overall conformation was very close to that of the PBP2x structure (except that PBP3 has no carboxy-terminal module).

All graphic visualizations were performed using WINMGM software (Rahman and Brasseur, 1994) from *ab initio* Technology.

Acknowledgements

This work was supported in part by the Belgian programme on Interuniversity Poles of Attraction initiated by the Belgian State, Prime Minister's Office, Services fédéraux des affaires scientifiques, techniques et culturelles (PAI no. P4/03), the Fonds de la Recherche Fondamentale Collective (contract no. 2.4534.95), the Fonds de la Recherche Scientifique Médicale (contract no. 3.4589.96), a Grant-in-Aid for Scientific Research (C) from the Ministry of Education, Science, Sports and Culture of Japan (no. 05680601), and Hoechst Marion Roussel, Romainville, France. R.B. is Research Director at the Fonds National de la Recherche Scientifique, Brussels. A.P. is fellow of the Fonds pour la formation à la Recherche dans l'Industrie et dans l'agriculture, Brussels. We thank S. Blacher (Liège University) for her help in microscopy.

References

- Adam, M., Fraipont, C., Rhazi, N., Nguyen-Distèche, M., Lakaye, B., Frère, J.M., *et al.* (1997) The bimodular G57-V577 polypeptide chain of the class B penicillin-binding protein 3 of *Escherichia coli* catalyzes peptide bond formation from thioesters and does not catalyze glycan chain polymerization from the lipid II intermediate. *J Bacteriol* 179: 6005-6009.
- Begg, K.J., Takasuga, A., Edwards, D.H., Dewar, S.J., Spratt, B.G., Adachi, H., *et al.* (1990) The balance between different peptidoglycan precursors determines whether *Escherichia coli* cells will elongate or divide. *J Bacteriol* 172: 6697-6703.
- Bi, E., and Lutkenhaus, J. (1990) FtsZ regulates frequency of cell division in *Escherichia coli*. *J Bacteriol* 172: 2765-2768.
- de Boer, P.A.J., Crossley, R.E., and Rothfield, L.I. (1992) The essential bacterial cell division protein FtsZ is a GTPase. *Nature* 359: 254-256.
- Broome-Smith, J.K., Hedge, P.J., and Spratt, B.G. (1985) Production of thiol-penicillin-binding protein 3 of *Escherichia coli* using a two primer method of site-directed mutagenesis. *EMBO J* 4: 231-235.
- Churchward, G., Belin, D., and Nagamine, Y. (1984) pSC101-derived plasmid which shows no sequence homology to other commonly used cloning vectors. *Gene* 31: 165-171.
- Degnen, G.E., and Cox, E.C. (1974) A conditional mutator gene in *Escherichia coli*: isolation, mapping and effector studies. *J Bacteriol* 117: 477-487.

- De Loot, H., Rosseneu, M., Brasseur, R., and Ruyschaert, J.M. (1986) Use of hydrophobicity profiles to predict receptor binding domains on apolipoprotein E and the low density lipoprotein apolipoprotein B-E receptor. *Proc Natl Acad Sci USA* 83: 2295-2299.
- Eisenberg, D. (1984) Three-dimensional structure of membrane and surface proteins. *Annu Rev Biochem* 53: 595-623.
- Eisenberg, D., Weiss, R.M., and Terwilliger, T.C. (1982) The helical hydrophobic moment: a measure of the amphiphilicity of a helix. *Nature* 299: 371-374.
- Fraipont, C., Adam, M., Nguyen-Distèche, M., Keck, W., Van Beeumen, J., Ayala, J., et al. (1994) Engineering and overexpression of periplasmic forms of the penicillin-binding protein 3 of *E. coli*. *Biochem J* 298: 189-195.
- Goffin, C., and Ghuysen, J.M. (1998) Multimodular penicillin-binding proteins: an enigmatic family of orthologs and paralogs. *Microbiol Mol Biol Rev* 62: 1079-1093.
- Goffin, C., Ayala, J.A., Nguyen-Distèche, M., and Ghuysen, J.M. (1993) Site-directed mutagenesis of dicarboxylic acid residues of the penicillin-binding module of the *Escherichia coli* penicillin-binding protein 3. *FEMS Microbiol Lett* 113: 247-252.
- Goffin, C., Fraipont, C., Ayala, J., Terrak, M., Nguyen-Distèche, M., and Ghuysen, J.M. (1996) The non-penicillin-binding module of the tripartite penicillin-binding protein 3 of *Escherichia coli* is required for folding and/or stability of the penicillin-binding module and the membrane-anchoring module confers cell septation activity on the folded structure. *J Bacteriol* 178: 5402-5409.
- Guzman, L.M., Belin, D., Carson, M.J., and Beckwith, J. (1995) Tight regulation, modulation, and high-level expression by vectors containing the arabinose P_{BAD} promoter. *J Bacteriol* 177: 4121-4130.
- Guzman, L.M., Weiss, D.S., and Beckwith, J. (1997) Domain-swapping analysis of FtsI, FtsL, and FtsQ, bitopic membrane proteins essential for cell division in *Escherichia coli*. *J Bacteriol* 179: 5094-5103.
- Hale, C.A., and de Boer, P.A.J. (1997) Direct binding of FtsZ to ZipA, an essential component of the septal ring structure that mediates cell division in *Escherichia coli*. *Cell* 88: 1-20.
- Hara, H., Yasuda, S., Horiuchi, K., and Park, J.T. (1997) A promoter for the first nine genes of the *Escherichia coli* *mra* cluster of cell division and cell envelope biosynthesis genes, including *ftsI* and *ftsW*. *J Bacteriol* 179: 5802-5811.
- van Heijenoort, J. (1996) Murein synthesis. In *Escherichia coli and Salmonella*. Neidhardt, F.C. (ed.). Washington, DC: American Society for Microbiology Press, pp. 1025-1034.
- Higgins, D.G., and Sharp, P.M. (1988) CLUSTAL: a package for performing multiple sequence alignment on a microcomputer. *Gene* 73: 237-244.
- Holm, L., and Sander, C. (1991) Database algorithm for generating protein backbone and side chain co-ordinates from a C (α) trace. *J Mol Biol* 218: 183-194.
- Holm, L., and Sander, C. (1992) Fast and simple Monte Carlo algorithm for side chain optimization in proteins. *Proteins* 14: 213-223.
- Houba-Hérin, N., Hara, H., Inouye, M., and Hirota, Y. (1985) Binding of penicillin to thiol-penicillin-binding protein 3 of *Escherichia coli*: identification of its active site. *Mol Gen Genet* 201: 499-504.
- Ishidate, K., Ursinus, A., Höltje, J.V., and Rothfield, L. (1998) Analysis of the length distribution of murein glycan strands in *ftsZ* and *ftsI* mutants of *Escherichia coli*. *FEMS Microbiol Lett* 168: 71-75.
- Koltun, W.L. (1965) Precision space-filling atomic models. *Biopolymers* 3: 665-679.
- Labesse, G., Colloc'h, N., Pothier, J., and Mornon, J.P. (1997) P-SEA: a new efficient assignment of secondary structure from C α trace of proteins. *Comput Appl Biosci* 13: 291-295.
- Laskowski, R.A., MacArthur, M.W., Moss, D.S., and Thornton, J.M. (1993) PROCHECK: a program to check the stereochemical quality of protein structures. *J Appl Crystallogr* 26: 283-291.
- Lowe, J., and Amos, L.A. (1998) Crystal structure of the bacterial cell-division protein FtsZ. *Nature* 391: 203-206.
- Lutkenhaus, J., and Addinall, S.G. (1997) A comprehensive review of the role of FtsZ in cell division in *E. coli* and other bacteria. *Annu Rev Biochem* 66: 93-116.
- Masui, Y., Coleman, J., and Inouye, M. (1983) Multipurpose expression cloning vehicles in *Escherichia coli*. In *Experimental Manipulation of Gene Expression*. Inouye, M. (ed.). New York: Academic Press, pp. 15-32.
- Nagasawa, H., Sakagami, Y., Suzuki, A., Suzuki, H., Hara, H., and Hirota, Y. (1989) Determination of the cleavage site involved in C-terminal processing of penicillin-binding protein 3 of *Escherichia coli*. *J Bacteriol* 171: 5890-5893.

- Nakagawa, J., Tamaki, S., Tomioka, S., and Matsuhashi, M. (1984) Functional biosynthesis of cell wall peptidoglycan by polymorphic bifunctional polypeptides. *J Biol Chem* 259: 13937-13946.
- Nanninga, N. (1998) Morphogenesis of *Escherichia coli*. *Microbiol Mol Biol Rev* 62: 110-129.
- Nguyen-Distèche, M., Fraipont, C., Buddelmeijer, N., and Nanninga, N. (1998) The structure and function of *Escherichia coli* penicillin-binding protein 3. *Cell Mol Life Sci* 54: 309-316.
- Pares, S., Mouz, N., Pétillot, Y., Hakenbeck, R., and Dideberg, O. (1996) X-ray structure of *Streptococcus pneumoniae* PBP2x, a primary penicillin target enzyme. *Nature Struct Biol* 3: 284-289.
- Pedersen, L.B., Angert, E.R., and Setlow, P. (1999) Septal localization of penicillin-binding protein 1 in *Bacillus subtilis*. *J Bacteriol* 181: 3201-3211.
- del Portillo, F.G., and de Pedro, M.A. (1990) Differential effect of mutational impairment of penicillin-binding proteins 1A and 1B on *Escherichia coli* strains harboring thermosensitive mutations in the cell division genes *ftsA*, *ftsQ*, *ftsZ*, and *pbpB*. *J Bacteriol* 172: 5863-5870.
- Poupon, A., and Mornon, J.P. (1998) Populations of hydrophobic amino acids within protein globular domains: identification of conserved 'topohydrophobic' positions. *Proteins Struct Funct Genet* 33: 329-342.
- Rahman, M., and Brasseur, R. (1994) WinMGM: a fast CPK molecular graphics program for analyzing molecular structure. *J Mol Graphics* 12: 212-218.
- RayChaudhuri, D., and Park, J.T. (1992) *Escherichia coli* cell division gene *ftsZ* encodes a novel GTP-binding protein. *Nature* 359: 251-254.
- Sali, A., and Blundell, T.L. (1993) Comparative protein modelling by satisfaction spatial restraints. *J Mol Biol* 234: 779-815.
- Sambrook, J., Fritsch, E.F., and Maniatis, T. (1989) *Molecular Cloning: a Laboratory Manual*. Cold Spring Harbor, NY: Cold Spring Harbor Laboratory Press.
- Spratt, B.G. (1975) Distinct penicillin binding proteins involved in the division, elongation, and shape of *Escherichia coli* K12. *Proc Natl Acad Sci USA* 72: 2999-3003.
- Taschner, P.E.M., Ypenburg, N., Spratt, B.G., and Woldringh, C.L. (1988) An amino acid substitution in penicillin-binding protein 3 creates pointed polar caps in *Escherichia coli*. *J Bacteriol* 170: 4828-4837.
- Terrak, M., Ghosh, T.K., van Heijenoort, J., Van Beeumen, J., Lampilas, M., Aszodi, J., et al. (1999) The catalytic, glycosyl transferase and acyl transferase modules of the cell wall peptidoglycan-polymerizing penicillin-binding protein 1 b of *Escherichia coli*. *Mol Microbiol* 34: 350-364.
- Wang, L., and Lutkenhaus, J. (1998) FtsK is an essential cell division protein that is localized to the septum and induced as part of the SOS response. *Mol Microbiol* 29: 731-740.
- Wang, L., Khattar, M.K., Donachie, W.D., and Lutkenhaus, J. (1998) FtsI and FtsW are localized to the septum in *Escherichia coli*. *J Bacteriol* 180: 2810-2816.
- Weiss, D.S., Chen, J.C., Ghigo, J.M., Boyd, D., and Beckwith, J. (1999) Localization of FtsI (PBP3) to the septal ring requires its membrane anchor, the Z ring, FtsA, FtsQ, and FtsL. *J Bacteriol* 181: 508-520.
- Wientjes, F.B., and Nanninga, N. (1991) On the role of the high molecular weight penicillin-binding proteins in the cell cycle of *Escherichia coli*. *Res Microbiol* 142: 333-344.